

DEPARTMENT OF LABOR

Occupational Safety and Health Administration

29 CFR Part 1910

[Docket No. OSHA–2007–0072]

RIN 1218-AB80

Walking-Working Surfaces and Personal Protective Equipment (Fall Protection Systems)

AGENCY: Occupational Safety and Health Administration (OSHA), Labor.

ACTION: Final rule.

SUMMARY: OSHA is revising and updating its general industry standards on walking-working surfaces to prevent and reduce workplace slips, trips, and falls, as well as other injuries and fatalities associated with walking-working surface hazards. The final rule includes revised and new provisions addressing, for example, fixed ladders; rope descent systems; fall protection systems and criteria, including personal fall protection systems; and training on fall hazards and fall protection systems. In addition, the final rule adds requirements on the design, performance, and use of personal fall protection systems.

The final rule increases consistency between the general industry and construction standards, which will make compliance easier for employers who conduct operations in both industry sectors. Similarly, the final rule updates requirements to reflect advances in technology and to make them consistent with more recent OSHA standards and national consensus standards. OSHA has also reorganized the requirements and incorporated plain language in order to make the final rule easier to understand and follow. The final rule also uses performance-based language whenever possible to give employers greater compliance flexibility.

DATES: *Effective date:* This final rule becomes effective on January 17, 2017. Some requirements in the final rule have compliance dates after the effective date. For further information on those compliance dates, see Section XI of the **SUPPLEMENTARY INFORMATION** section. In addition, this final rule contains information collections subject to the Office of Management and Budget (OMB) approval under the Paperwork Reduction Act, and the Department is submitting requests to OMB to obtain that approval. The information collections will not take effect until the date OMB approves the information

collection request or the date the requirement would take effect as explained elsewhere in this document. The Department will publish a document in the **Federal Register** to announce OMB's disposition of the information collection requests.

ADDRESSES: In accordance with 28 U.S.C. 2112(a)(2), OSHA designates Ms. Ann Rosenthal, Associate Solicitor of Labor for Occupational Safety and Health, Office of the Solicitor, U.S. Department of Labor, Room S–4004, 200 Constitution Avenue NW., Washington, DC 20210, to receive petitions for review of the final rule.

FOR FURTHER INFORMATION CONTACT:

Press inquiries: Mr. Frank Meilinger, Director, Office of Communications, OSHA, U.S. Department of Labor, Room N–3647, 200 Constitution Avenue NW., Washington, DC 20210; telephone (202) 693–1999; email meilinger.francis2@dol.gov.

General information and technical inquiries: Mr. Mark Hagemann, Director, Office of Safety Systems, Directorate of Standards and Guidance, OSHA, U.S. Department of Labor, Room N–3609, 200 Constitution Avenue NW., Washington, DC 20210; telephone (202) 693–2255, email hagemann.mark@dol.gov.

Copies of this Federal Register document: Copies of this **Federal Register** document are available at <http://www.regulations.gov>, the Federal eRulemaking Portal. Copies also are available at OSHA Office of Publications, U.S. Department of Labor, Room N–3101, 200 Constitution Avenue NW., Washington, DC 20210; telephone (202) 693–1888 (OSHA's TTY (887) 889–5627). This document, as well as news releases and other relevant documents, are available on OSHA's website at <http://www.osha.gov>.

SUPPLEMENTARY INFORMATION:**Table of Contents**

The following table of contents identifies the major sections of the preamble to the final rule:

- I. Background
 - A. References and Exhibits
 - B. Introduction and Basis for Agency Action
 - C. Summary of the Final Economic Analysis
 - D. Events Leading to the Final Rule
- II. Analysis of Risk
 - A. Introduction
 - B. Nature of the Risk
 - C. Fatality and Injury Data
- III. Pertinent Legal Authority
- IV. Summary and Explanation of the Final Rule
 - A. Final Subpart D
 - B. Final § 1910.140

- C. Other Revisions to 29 CFR Part 1910
- V. Final Economic and Final Regulatory Flexibility Screening Analysis
 - A. Introduction
 - B. Assessing the Need for Regulation
 - C. Profile of Affected Industries, Firms, and Workers
 - D. Benefits, Net Benefits, Cost Effectiveness, and Sensitivity Analysis
 - E. Technological Feasibility
 - F. Costs of Compliance
 - G. Economic Feasibility and Regulatory Flexibility Screening Analysis
 - H. Regulatory Flexibility Screening Analysis
 - I. Sensitivity Analyses
 - J. References
- VI. Federalism
- VII. State-Plan Requirements
- VIII. Unfunded Mandates Reform Act
- IX. Consultation and Coordination With Indian Tribal Governments
- X. Office of Management and Budget Review Under the Paperwork Reduction Act of 1995
- XI. Dates

I. Background*A. References and Exhibits*

This **Federal Register** document references materials in Docket No. OSHA–2007–0072, which is the docket for this rulemaking. OSHA also references documents in the following dockets, which the Agency incorporates by reference into this rulemaking:

- 1990 proposed rule on Walking and Working Surfaces (29 CFR 1910, subpart D)—Docket No. OSHA–S041–2006–0666 (formerly Docket No. S–041);
- 1990 proposed rule on Personal Protective Equipment—Fall Protection—Docket No. OSHA–S057–2006–0680 (formerly Docket No. S–057);
- 2003 reopening of the rulemaking record—Docket No. OSHA–S029–2006–0662 (formerly Docket No. S–029);
- 1994 final rule on Fall Protection in the Construction Industry—Docket No. OSHA–S206–2006–0699 (formerly Docket No. S–206);
- 1983 and 1985 proposed rules on Powered Platforms for Building Maintenance—Docket Nos. OSHA–S700–2006–0722 and OSHA–S700A–2006–0723 (formerly Dockets Nos. S–700 and S–700A, respectively); and
- 2014 final rule on Electric Power Generation, Transmission, and Distribution; Electrical Protective Equipment—Docket No. OSHA–S215–2006–0063 (Formerly Docket No. S–215).

All of these dockets are available for viewing at <http://www.regulations.gov>, the Federal eRulemaking Portal.

Citations to documents in Docket No. OSHA–2007–0072: This document references exhibits in this rulemaking record, Docket No. OSHA–2007–0072, as “Ex.,” followed by the last sequence

of numbers in the document identification (ID) number. For example, “Ex. 44” is a reference to document ID number OSHA–2007–0072–0044 in this rulemaking docket.

Citations to the transcripts of the rulemaking hearing: This document includes citations to the informal public hearing on the proposed rule. All of the hearing transcripts are included in exhibit 329. Thus, “Ex. 329 (1/19/2011, p. 75)” refers to page 75 of the January 19, 2011, hearing transcript.

Citations to other dockets: This document also references other OSHA dockets. Documents in those dockets are cited as the docket number followed by the last sequence of numbers in the document ID number. For example, “Ex. OSHA–S029–2006–0662–0014” refers to “Docket No. OSHA–S029–2006–0662, Ex. 14” in the 2003 reopening of the rulemaking record on subparts D and I (formerly Docket No. S–029).

Docket: The exhibits in this rulemaking docket (Docket No. OSHA–2007–0072), as well as the dockets OSHA incorporated by reference in this rulemaking, are available to read and download by searching the docket number or document ID number at <http://www.regulations.gov>. Each docket index lists all documents and exhibits in that docket, including public comments, supporting materials, hearing transcripts, and other documents. However, some documents (e.g., copyrighted material) in those dockets are not available to read or download from that website. All documents are available for inspection and copying at the OSHA Docket Office, Room N–2625, U.S. Department of Labor, 200 Constitution Avenue NW., Washington, DC 20210; telephone number (202) 693–2350 (OSHA TTY (887) 889–5627).

B. Introduction and Basis for Agency Action

Workers in many diverse general industry workplaces are exposed to walking-working surface hazards that can result in slips, trips, falls and other injuries or fatalities. According to the Bureau of Labor Statistics (BLS) data, slips, trips, and falls are a leading cause of workplace fatalities and injuries in general industry, which indicates that workers regularly encounter these hazards (see Section II below).

The final rule covers all general industry walking-working surfaces, including but not limited to, floors, ladders, stairways, runways, dockboards, roofs, scaffolds, and elevated work surfaces and walkways. To protect workers from hazards associated with those surfaces,

particularly hazards related to falls from elevations, the final rule updates and revises the general industry Walking-Working Surfaces standards (29 CFR part 1910, subpart D). The final rule includes revised and new provisions that address, for example, fixed ladders; rope descent systems; fall protection systems and criteria, including personal fall protection systems; and training on fall hazards and fall protection systems. In addition, the final rule adds new requirements on the design, performance, and use of personal fall protection systems to the general industry Personal Protective Equipment (PPE) standards (29 CFR part 1910, subpart I). These and other measures the final rule incorporates reflect advances in technology and industry best practices that have been developed since OSHA adopted subpart D in 1971.

The final rule also gives employers greater flexibility to prevent and eliminate walking-working surface hazards. For example, the final rule, like the construction Fall Protection Standards (29 CFR part 1926, subpart M), gives employers flexibility to protect workers from falling to a lower level by using personal fall protection systems, including personal fall arrest, travel restraint, and work positioning systems; instead of requiring the use of guardrail systems, which the existing rule mandates. In addition, consistent with section 6(b)(5) of the Occupational Safety and Health Act of 1970 (OSH Act) (29 U.S.C. 651, 655(b)(5)) the final rule uses performance-based language in place of specification language, where possible, to increase compliance flexibility for employers. OSHA believes the flexibility the final rule provides will allow employers to select and provide the controls they determine will be most effective in the particular workplace operation or situation to protect their workers and prevent injuries and fatalities from occurring.

The final rule also increases harmonization between OSHA standards, which many stakeholders requested. Of particular importance, OSHA increased consistency between the final rule and OSHA’s construction Scaffolds, Fall Protection, and Stairway and Ladder standards (29 CFR part 1926, subparts L, M, and X), which makes compliance easier for employers who conduct operations in both industry sectors. The revisions in and additions to the final rule will allow employers to use the same fall protection systems and equipment and follow the same practices when they perform either general industry or construction activities.

The final rule also increases consistency by incorporating provisions from other standards OSHA adopted more recently, including Powered Platforms for Building Maintenance (29 CFR 1910.66) and Scaffolds, Ladders and Other Working Surfaces in Shipyard Employment (29 CFR part 1915, subpart E).¹ In particular, § 1910.140 drew personal fall arrest system requirements from Appendix C (Mandatory) of the Powered Platform standard (§ 1910.66). The experience OSHA gained on that standard shows that those requirements are effective in protecting workers from fall hazards.

OSHA also drew many provisions in the final rule from national consensus standards, including ANSI/ASSE A1264.1–2007, Safety Requirements for Workplace Walking/Working Surfaces and Their Access; Workplace, Floor, Wall and Roof Openings; Stairs and Guardrail Systems; ANSI/ASSE Z359.1–2007, Safety Requirements for Personal Fall Arrest Systems, Subsystems and Components; and ANSI/IWCA I–14.1–2001, Window Cleaning Safety Standard. Many stakeholders recommended that OSHA incorporate the requirements in those standards into the final rule. OSHA agrees with stakeholders that national consensus standards represent industry best practices and reflect advancements in technology, methods, and practices developed in the years since the Agency adopted the existing rule.

OSHA also has made the final rule easier to understand and follow by reorganizing and consolidating provisions, using plain language, and adding informational tables, illustrations, and appendices. For example, the final rule adds two non-mandatory appendices to final § 1910.140 that address planning for, selecting, using, and inspecting personal fall protection systems (appendix C) and test methods and procedures for personal fall arrest work positioning systems (appendix D).

OSHA’s efforts to revise and update the existing walking-working surfaces standards have been ongoing since 1973. Over that time, OSHA has gathered and analyzed a large body of data and information on walking-working surface hazards and methods to prevent and eliminate them. After careful examination and analysis of the rulemaking record as a whole, OSHA has determined that the requirements in this final rule will significantly reduce

¹ Where necessary, the final rule also revises provisions in some current general industry standards (e.g., 29 CFR part 1910, subparts F, N, and R) to ensure that they are consistent with the final rule (See Section IV(C) below).

the number of worker deaths and injuries that occur each year due to these hazards, particularly workplace slip, trip, and fall fatalities and injuries. OSHA estimates that final standard rule will prevent 29 fatalities and 5,842 injuries annually (See Sections II and V).

OSHA believes that many employers already are in compliance with many provisions in the final rule; therefore, they should not have significant problems implementing it. OSHA also has included measures to make implementation of the final rule easier for employers. The final rule provides extended compliance dates for implementing some requirements and applies other requirements only prospectively. For example, the final rule gives employers as much as 20 years to equip fixed ladders with personal fall arrest or ladder safety systems. Moreover, since the final rule incorporates requirements from national

consensus standards, most equipment manufacturers already provide equipment and systems that meet the requirements of the final rule.

C. Summary of the Final Economic Analysis

The OSH Act requires OSHA to make certain findings with respect to standards. One of these findings, specified by Section 3(8) of the OSH Act, requires an OSHA standard to address a significant risk and to reduce this risk significantly. (See *Industrial Union Dep't v. American Petroleum Institute*, 448 U.S. 607 (1980).) As discussed in Section II of this preamble, OSHA finds that slips, trips, and falls constitute a significant risk, and estimates that the final standard will prevent 29 fatalities and 5,842 injuries annually. Section 6(b) of the OSH Act requires OSHA to determine if its standards are technologically and economically feasible. As discussed in

Section V of this preamble, OSHA finds that this final standard is economically and technologically feasible. The table below summarizes OSHA's findings with respect to the estimated costs, benefits, and net benefits of this standard. The annual benefits are significantly in excess of the annual costs. However, it should be noted that under the OSH Act, OSHA does not use the magnitude of net benefits as the decision-making criterion in determining what standards to promulgate.

The Regulatory Flexibility Act (5 U.S.C. 601, as amended) requires that OSHA determine whether a standard will have a significant economic impact on a substantial number of small firms. As discussed in Section V, the Assistant Secretary examined the small firms affected by this final rule and certifies that these provisions will not have a significant impact on a substantial number of small firms.

Net Benefits of the Final Revision to OSHA's Walking-Working Standards

Annualized Costs	
§1910.22 General Requirements	\$33.2
§1910.23 Ladders	\$11.3
§1910.24 Step Bolts and Manhole Steps	\$18.0
§1910.27 Scaffolds and Rope Descent Systems	\$71.6
§1910.28 Duty to Have Fall Protection and Falling Object Protection	\$55.9
§1910.29 Fall Protection Systems and Falling Object Protection – Criteria and Practices	\$13.1
§1910.30 Training Requirements	\$74.2
§1910.132 General Requirements	\$12.7
§1910.140 Personal Fall Protection Systems	\$11.0
Rule Familiarization	\$4.1
Total Annual Costs	\$305.0 million
Annual Benefits	
Number of Injuries Prevented	5,842
Number of Fatalities Prevented	29
Monetized Benefits (assuming \$62,000 per injury and \$8.7 million per fatality prevented)	\$614.5 million
OSHA standards that are updated and consistent with voluntary standards.	Unquantified
Net Benefits (benefits minus costs)	\$309.5 million

Source: U.S. Department of Labor, OSHA, Directorate of Standards and Guidance, Office of Regulatory Analysis-Safety.

D. Events Leading to the Final Rule

Existing standards. In 1971, OSHA adopted the existing general industry standards on Walking-Working Surfaces (29 CFR part 1910, subpart D) and Personal Protective Equipment (PPE) (29 CFR part 1910, subpart I) pursuant to Section 6(a) of the OSH Act (29 U.S.C.

655(a)). Section 6(a) permitted OSHA, during the first two years following the effective date of the OSH Act, to adopt as occupational safety and health standards any established Federal and national consensus standards. OSHA adopted the subpart D and I standards from national consensus standards in

existence at the time. Since then, those national consensus standards have been updated and revised, some several times, to incorporate advancements in technology and industry best practices. OSHA's existing walking-working surfaces standards have not kept pace with those advancements.

Early rulemaking efforts. In 1973, OSHA published a proposed rule to revise the subpart D standards (38 FR 24300 (9/6/1973)), but withdrew the proposal in 1976, saying it was outdated (41 FR 17227 (4/23/1976)). That year OSHA conducted stakeholder meetings around the country to obtain public comment on revising subpart D. After reviewing information gathered from those meetings, OSHA determined that it needed to gather additional scientific and technical data, research, and information to support effective revisions to subpart D.

From 1976 through the 1980s, OSHA gathered a large body of scientific and technical research and information, including:

- Recommendations for fall prevention, ladders, scaffolds, slip resistance, and handrails from the University of Michigan;
- Studies on guardrails, slip resistance, scaffolds, and fall prevention from the National Bureau of Standards (now the National Institute of Standards and Technology);
- Analysis of various walking-working surfaces by Texas Tech University;
- Accident, injury, and fatality data from the Bureau of Labor Statistics (BLS); and
- National consensus standards from the American National Standards Institute (ANSI), American Society of Testing and Materials (ASTM), and the American Society of Mechanical Engineers (ASME).

1990 proposed rules. The data, research, and information OSHA gathered provided the basis for OSHA's 1990 companion proposals to revise and update the walking-working surfaces standards in subpart D (55 FR 13360 (4/10/1990)) and add personal fall protection system requirements to subpart I (55 FR 13423 (4/10/1990)). The two proposals were interdependent with respect to personal fall protection systems. That is, the subpart D proposal would have established a "duty to provide" fall protection, including personal fall protection systems while the subpart I proposal would have established design, performance, and use criteria for personal fall protection systems.

OSHA received comments and held an informal public hearing on the two proposals (55 FR 29224), but did not finalize either.

1994 final rule revising subpart I. In 1994, OSHA published a final rule updating the general industry PPE standards (59 FR 16334 (4/6/1994)). The final rule added new general provisions requiring that employers conduct

hazard assessments; select proper PPE; remove defective or damaged PPE from service; and provide worker training in the proper use, care, and disposal of PPE (§ 1910.132). It also revised design, selection, and use requirements for specific types of PPE. However, the final rule did not apply the new general provisions to personal fall protection systems or include specific requirements addressing such systems.

2003 record reopening. On May 2, 2003, OSHA published a notice reopening the record on the subpart D and I rulemakings to refresh the record, which had grown stale in the years since OSHA published the 1990 proposed rules (68 FR 23528). Based on comments and information OSHA received, including information on significant technological advances in fall protection, particularly personal fall protection systems, OSHA determined that a new proposed rule was needed.

2010 proposed rule. On May 24, 2010, OSHA published a consolidated proposed rule on subparts D and I (75 FR 28862). The Agency provided 90 days, until August 23, 2010, for stakeholders to submit comments on the proposed rule, the preliminary economic analysis, and the issues the Agency raised in the proposal. The Agency received 272 comments, including comments from workers, employers, trade associations, occupational safety and health consultants, manufacturers, labor representatives, and government agencies (Exs. 52 through 326).

Several stakeholders requested an informal public hearing on the proposed rule (Exs. 172; 178; 180; 201; 256). OSHA granted the requests for a public hearing (75 FR 69369 (11/10/2010)), and convened the hearing on January 18, 2011, in Washington, DC (Ex. 329). Administrative Law Judge John M. Vittone presided over the four-day hearing during which 39 stakeholders presented testimony (Ex. 329). At the close of the hearing on January 21, 2011, Judge Vittone ordered that the hearing record remain open for an additional 45 days, until March 7, 2011, for the submission of new factual information and data relevant to the hearing (Exs. 327; 330; 328). He also ordered that the record remain open until April 6, 2011, for the submission of final written comments, arguments, summations, and briefs (Exs. 327; 331–370). On June 13, 2011, Judge Vittone issued an order closing the hearing record and certifying it to the Assistant Secretary of Labor for Occupational Safety and Health (Ex. 373).

II. Analysis of Risk

A. Introduction

To promulgate a standard that regulates exposure to workplace hazards, OSHA must demonstrate that exposure to those hazards poses a "significant risk" of death or serious physical harm to workers, and that the standard will substantially reduce that risk. The Agency's burden to establish significant risk derives from the Occupational Safety and Health Act of 1970 (OSH Act) (29 U.S.C. 651 *et seq.*).

Section 3(8) of the OSH Act requires that workplace safety and health standards be "reasonably necessary or appropriate to provide safe or healthful employment and places of employment" (29 U.S.C. 652(8)). A standard is reasonably necessary and appropriate within the meaning of section 3(8) if it materially reduces a significant risk of harm to workers. The Supreme Court, in the "Benzene" decision, stated that section 3(8) "implies that, before promulgating any standard, the Secretary must make a finding that the workplaces in question are not safe" (*Indus. Union Dep't, AFL-CIO v. Am. Petroleum Inst. (Benzene)*, 448 U.S. 607, 642 (1980)). Examining section 3(8) more closely, the Court described OSHA's obligation to demonstrate significant risk:

"[S]afe" is not the equivalent of "risk-free." . . . [A] workplace can hardly be considered "unsafe" unless it threatens the workers with a significant risk of harm.

Therefore, before [the Secretary] can promulgate any permanent health or safety standard, the Secretary is required to make a threshold finding that the place of employment is unsafe—in the sense that significant risks are present and can be eliminated or lessened by a change in practices. (*Id.* (Emphasis in original)).

Relying on the U.S. Census' Statistics of U.S. Businesses for 2007, OSHA estimates that 6.9 million general industry establishments employing 112.3 million employees will be affected by the final standard. For the industries affected by the final standard, OSHA examined fatalities and lost-workday injuries for falls to a lower level.

In the proposed rule, the Agency preliminarily concluded that falls constitute a significant risk and that the proposed standards would substantially reduce the risk of falls to employees (75 FR 28861, 28865–28866 (5/24/2010)). The analysis of U.S. Bureau of Labor Statistics (BLS) data from 1992 to 2004 identified an annual average of 300 fatal falls, 213 (71 percent) of which resulted from falls to a lower level and an annual average of 299,404 non-fatal falls resulting in lost-workday injuries,

79,593 (26 percent) of which were as a result of falls to a lower level. The Agency's analysis also estimated that compliance with the proposed requirements in subparts D and I annually would prevent 20 fatal to a lower level and 3,706 lost-workday injuries due to falls to a lower level.

Based on the analysis presented in this section, which OSHA updated with more recent data, and in the Final Economic and Final Regulatory Flexibility Screening Analysis (FEA) (Section V), OSHA determines that workplace exposure to hazards associated with walking-working surfaces, particularly the hazards of falling to a lower level, poses a significant risk of serious physical harm or death to workers in general industry. BLS data from 2006–2012 show that an average of 261 fatal falls to a lower level occurred annually in general industry. In addition, BLS data for 2006–2012 indicate that an average of 48,379 lost-workday (LWD) injuries from falls to a lower level occurred annually in general industry.

OSHA also concludes, based on this section and the FEA, that the “practices, means, methods, operations, or processes” the final rule requires will substantially reduce that risk. Specifically, the Agency estimates that full compliance with the final rule will prevent 29 fatalities from falls to a lower level and 5,842 lost-workday injuries from falls to a lower level annually in general industry.

B. Nature of the Risk

Every year many workers in general industry experience slips, trips, falls and other injuries associated with walking-working surface hazards. These walking-working surface hazards result in worker fatalities and serious injuries, including lost-workday injuries. Slips, trips, and falls, including falls on the same level, can result in injuries such as fractures, contusions, lacerations, and sprains, and may even be fatal. Falls to lower levels can increase the severity of injuries as well as the likelihood of death. Falls on the same level can also result in strains and sprains when employees try to “catch” themselves to prevent falling.

There are many walking-working surface hazards that can cause slips, trips, and falls. These hazards include damaged or worn components on personal fall protection systems and rope descent systems; portable ladders used for purposes for which they were not designed; fixed ladders that are not equipped with fall protection; damaged stair treads; snow, ice, water, or grease on walking-working surfaces such as floors; and dockboards that are not properly secured or anchored.

Identifying walking-working surface hazards and deciding how best to protect employees is the first step in reducing or eliminating the hazards. To that end, the final rule requires that employers regularly inspect walking-working surfaces. It also requires that employers assess walking-working surfaces to determine if hazards are present, or likely to be, that necessitate the use of personal fall protection

systems (§§ 1910.132(d); 1910.28(b)(1)(v)). In addition, employers must train employees on fall hazards and equipment plus the proper use of personal fall protection systems (§§ 1910.30, 1910.132(f)). After employers have assessed the workplace and identified fall hazards, final § 1910.28 requires employers to provide fall protection to protect their employees from falls. Final §§ 1910.29 and 1910.140 specify the criteria fall protection systems must meet, such as strength and performance requirements. Section A of the FEA provides detailed information on the incidents the final rule will prevent.

C. Fatality and Injury Data

Fatalities. The BLS Census of Fatal Occupational Injuries (CFOI) has listed falls as one of the leading causes of workplace fatalities for many years. From 1999 to 2010, falls were second only to highway incidents in terms of fatal injuries. In 2011, slips, trips, and falls were the third leading cause of fatal occupational injuries and in 2012, the fourth leading cause of these types of injuries. Many fatal falls occur in general industry. From 2006–2012, approximately one-third of all fatal falls in private industry were falls to a lower level in general industry.

OSHA examined fall fatalities for 2006 to 2012 in industries covered by the final standard using data from the BLS Census of Fatal Occupational Injuries (CFOI). Table II–1, summarizing the data in Table V–6 of the FEA, shows the total number of fatal falls to a lower level from 2006 to 2012.

Table II-1. Fatal Falls to a Lower Level – General Industry

Year	Fatal Falls to a Lower Level
2006	283
2007	279
2008	234
2009	237
2010	243
2011	278
2012	270

As described in Table V–6 of the FEA, over the seven-year period, the Professional, Scientific, and Technical Services industry and the Administrative and Support Services

industry (NAICS codes 541 and 561, respectively) accounted for 27 percent of the fatal falls, while the Manufacturing (NAICS 31–33) and Transportation (NAICS 48) sectors

accounted for 9.6 and 7.1 percent of the fatal falls, respectively. Among all three-digit NAICS codes affected by the standard, BLS reported the highest number of fatal falls in NAICS code 561,

Administrative and Support Services. Although not shown in the table, a large majority of the fatalities for Administrative and Support Services—86 percent for the seven-year period 2006–2012—occurred in the industry concerned with services to buildings and dwellings (NAICS 5617). Based on these data, OSHA estimates that, on average, 261 deaths per year resulted from falls to a lower level and would be directly affected by the final standard.

Table V–7 of the FEA also includes data on fatal falls. That table displays the number of fatal falls by type of fall and industry sector for 2006–2010. These data indicate that during this period, there were, on average, 255 fatal falls to a lower level in general industry establishments when fatal falls are summed across all affected two-digit NAICS industries. While the annual number of fatal falls decreased and then rose since 2006, the average annual number of fatal falls to a lower level from 2006–2010 (255 fatal falls to a lower level) and 2011–2012 (274 fatal falls to a lower level)² remains at approximately the same level. In addition, falls remained one of the leading causes of workplace fatalities throughout this time, as discussed above.

Injuries. OSHA examined lost-workday injuries using data from BLS's *Survey of Occupational Injuries and Illnesses*. Falls have been one of the leading causes of lost-workday injuries for the last several years. From 2006–2010, falls were consistently the third leading cause of injuries and illnesses, behind overexertion and contact with objects and equipment. From 2011–2012, slips, trips, and falls were the second leading cause of injuries and illnesses, behind only overexertion.

In addition to being a major source of lost-workday injuries, falls to a lower level were also some of the most severe. Falls to a lower level had the second highest median days away from work, a key measure of the severity of an injury or illness, every year from 2006–2012, except 2010 (where it was the third highest). BLS data also demonstrate that the majority of lost-workday falls to a lower level that occurred in private industry occurred in general industry. More specifically, for 2006–2012, approximately three-quarters of the lost-workday falls to a lower level in private industry occurred in general industry.

Table V–8 of the FEA shows the average number of lost-workday injuries due to falls in general industry, by type of fall, for 2006–2012. Based on these

data, OSHA estimates that, on average, approximately 48,379 serious (lost-workday) injuries per year resulted from falls to a lower level and would be directly affected by the final standard.

Table II–2, based on BLS's *Survey of Occupational Injuries and Illnesses*, provides additional information about the median number of days away from work for lost-workday falls to a lower level from 2006–2012. Table II–2 displays the median number of days away from work attributed to falls to a lower level for each industry sector and private industry as a whole. In 2012, for example, the number of median days away from work for falls to a lower level in private industry as a whole was 18, while the median days away from work for all lost-workday injuries and illnesses in private industry as a whole was 8. Similarly, in 2012, the median days away from work for falls to a lower level in nearly every general industry sector was higher, and in many cases, much higher, than the median days away from work for all lost-workday injuries and illnesses in those sectors. This suggests that falls to a lower level are among the most severe lost-workday injuries.

**Table II-2. Lost-Workday Falls to a Lower Level – General Industry, 2006-2012
Median Days Away from Work, by Industry Sector**

Industry Sector	2006	2007	2008	2009	2010	2011	2012
Manufacturing	14	14	16	12	16	20	20
Trade, Transportation, Utilities	14	16	17	22	25	20	21
Information	15	8	10	34	27	30	13
Financial Activities	10	10	5	5	14	25	16
Professional and Business Services	14	12	13	12	14	11	21
Educational and Health Services	8	8	7	6	6	7	13
Leisure and Hospitality	7	7	14	11	6	11	7
Other Services, except Public Administration	11	4	33	3	8	35	10
All Private Industry	14	15	15	14	16	21	18

² Reference year 2011 is the first year in which the Injuries, Illnesses, and Fatalities (IIF) program used the Occupational Injury and Illness Classification System (OIICS), version 2.01, when

classifying Event or Exposure, Primary Source, Secondary Source, Nature, and Part of Body. Due to substantial differences between OIICS 2.01 and the original OIICS structure, which was used from

1992 to 2010, data for these case characteristics from 2011 forward should not be compared to prior years.

Based on the number of fatalities and lost-workday injuries reported by BLS for falls to a lower level, and evidence that non-fatal injuries are among the most severe work-related injuries, OSHA finds that workers exposed to fall hazards are at a significant risk of death or serious injury.

Several stakeholders agreed that fall hazards present a significant risk of injury and death (Exs. 63; 121; 158; 189; 363; OSHA-S029-2006-0662-0177; OSHA-S029-2006-0662-0350). For example, Bill Kojola of the American Federation of Labor and Congress of Industrial Organizations (AFL-CIO) asserted:

Fall hazards remain one of the most serious problems faced by millions of workers. We are convinced that the proposed changes, when implemented as a result of promulgating a final rule, will prevent fatalities and reduce injuries from fall hazards (Ex. 363).

Similarly, in his written comments, Robert Miller of Ameren Corporation stated that the proposed rule is a positive approach towards eliminating at-risk conditions and events (Ex. 189).

Charles Lankford, of Rios and Lankford Consulting International, challenged OSHA's preliminary finding that falls present a significant risk and that revising the general industry fall protection standards is necessary to address the problem. Mr. Lankford used NIOSH and BLS data to argue, respectively, that the final rule is not necessary because the rate of fall fatalities decreased from 1980-1994 and "held steady" from 1992 to 1997 (Ex. 368). OSHA is not persuaded by Mr. Lankford's argument because, as discussed above, current BLS data from 2006-2012 show that an average of 261 fatal falls to a lower level occurred annually and these falls continue to be a leading cause of fatal occupational injuries in general industry. OSHA believes this shows that a significant risk of death from falls to a lower level still exists in general industry workplaces. With regard to Mr. Lankford's claim that fall fatalities held "steady" from 1992-1997, according to the BLS data, the number of fatal falls increased each year during that period (with the exception of 1995), and reached a 6-year high in 1997.

In addition, Mr. Lankford argued that:

[H]istorical incident rates for non-fatal falls also do not display an increasing fall problem. The all-industries non-fatal fall incidence rate has declined every year since 2003 (the oldest year in the BLS Table I consulted), so the decline in rates is not attributable to the current recession. If we exclude 2008 and 2009 data, manufacturing did not show a change. Yet 2006 and 2007

showed lower injury incidence rates than 2003 and 2004 (Ex. 368).

A review of 2003-2009 BLS data on the incidence rates of nonfatal occupational injuries and illnesses resulting from falls could not reproduce Mr. Lankford's claims. As previously discussed, falls continue to be one of the leading causes of lost-workday injuries. Falls to a lower level are also some of the most severe lost-workday injuries. In 2012, for example, the number of median days away from work for falls to a lower level in private industry as a whole was 18, while the median days away from work for all lost-workday injuries and illnesses in private industry as a whole was 8.

Mr. Lankford also suggested that fatal falls are a greater problem in the "goods producing sector" than the "service sector." However, this assertion is not supported by the BLS data. As described in Table V-6 of the FEA, from 2006-2012, among all three-digit NAICS codes affected by the standard, BLS reported the highest number of fatal falls in a "service sector" (NAICS code 561, Administrative and Support Services). Further, over the seven-year period, the Professional, Scientific, and Technical Services industry and the Administrative, and Support Services industry (NAICS codes 541 and 561, respectively) accounted for 28 percent of the fatal falls.

Based on the evidence and analysis, OSHA disagrees with Mr. Lankford's comment. As mentioned above, after examining recent BLS data (2006-2012), OSHA finds that the available evidence points to a significant risk. OSHA believes that the risk of injury, combined with the risk of fatalities constitutes a significant safety threat that needs to be addressed by rulemaking—specifically a revision to subparts D and I. OSHA believes that the revisions to subparts D and I are reasonable and necessary to protect affected employees from those risks. Based on the BLS data, the Agency estimates that full compliance with the revised walking-working surfaces standards will prevent 28 fatalities and 4,056 lost-workday injuries due to falls to a lower level annually. OSHA finds that these benefits constitute a substantial reduction of significant risk of harm from these falls.

Several commenters urged OSHA to expand its analysis to include fatalities and injuries resulting from falls on the same level (Exs. 77; 329 (1/20/2011 pp. 42, 60-61); 329 (1/21/2011, pp. 200-203); 330). However, the Agency finds that, with regard to its significant risk analysis, the data for falls to a lower

level constitute the vast majority of the risk that the standard addresses, *i.e.*, falls from elevations. Analysis in the FEA (Section V) demonstrates that fatal falls on the same level made up a small portion of all fatal falls. Table V-7 of the FEA shows that, for the five-year period 2006 to 2010, falls on the same level accounted for about 24 percent of total fall fatalities. For non-fatal injuries, the Agency recognizes that falls on the same level represent a significant portion of lost-workday fall-injuries. Table V-8 of the FEA shows that, in general industry, falls on the same level accounted for 68 percent of all falls resulting in lost-workday injuries, while falls to a lower level accounted for only 24 percent.

However, as discussed in the FEA, the final rule has relatively few new provisions addressing falls on the same level, such as slips and trips from floor obstructions or wet or slippery working surfaces. The requirements expected to yield the largest benefits from preventing falls on the same level are found in final § 1910.22 General requirements. These final provisions will result in safety benefits to workers by controlling worker exposure to fall hazards on walking-working surfaces, especially on outdoor surfaces. Tables V-11 and V-13 of the FEA show that OSHA estimates only 1 percent of fatal falls on the same level and 1 percent of lost-workday falls on the same level will be prevented by these provisions.

Since falls to a lower level constitute the vast majority of the risk the final rule addresses, OSHA's significant risk analysis includes only falls to a lower level. Because of this, OSHA notes the final risk analysis may understate the risk of falls in general industry, since falls on the same level account for 68 percent of falls resulting in a lost-workday injury.

The U.S. Chamber of Commerce questioned whether OSHA's estimate of the benefits of the proposed standard justified the efforts undertaken to issue the standard:

We note with some surprise that OSHA's analysis suggests this new regulation will have a relatively minor impact on the total number of fatalities attributed to falls from height. OSHA claims that for the years 1992-2007 there were an average of 300 fatal falls per year from height. OSHA calculates that this standard will result in 20 fewer fatal falls per year. We do not mean to diminish the significance of saving 20 lives, but OSHA seems to be projecting less impact than a standard of this scope would suggest. Indeed, OSHA even admits in the preamble that: For the purposes of this analysis, OSHA did not attempt a quantitative analysis of how many fatal falls could be prevented by full and complete compliance with the existing standard. However a *qualitative examination*

of the fatal falls to a lower level shows that a majority, and perhaps a large majority, could be prevented by full compliance with the existing regulations. (Emphasis added) This raises questions about whether such a sweeping new standard as this one, which will create confusion and new enforcement exposures, is indeed warranted, or if OSHA would achieve the same or better results by generating more complete compliance with current requirements (Ex. 202).

First, far from creating confusion, this rulemaking assures that OSHA rules will be in much closer accord with existing consensus standards and practices and that OSHA's general industry fall protection requirements will be better aligned with its construction fall protection standard. There are many situations in which improved enforcement of existing rules would be highly cost beneficial but is not possible. On the other hand, OSHA can enforce new provisions to this rule at minimal marginal costs per inspection since the bulk of the costs of an inspection involves the time to reach the site, walk through the site looking for violations of all OSHA rules, and conduct the necessary closing and enforcement conferences.

III. Pertinent Legal Authority

The purpose of the OSH Act is to "assure so far as possible every working man and woman in the nation safe and healthful working conditions and to preserve our human resources" (29 U.S.C. 651(b)). To achieve this goal, Congress authorized the Secretary of Labor to issue and to enforce occupational safety and health standards (see 29 U.S.C. 655(a) (authorizing summary adoption of existing consensus and Federal standards within two years of the OSH Act's effective date); 655(b) (authorizing promulgation of standards pursuant to notice and comment); and 654(a)(2) (requiring employers to comply with OSHA standards)).

A safety or health standard is a standard "which requires conditions, or the adoption or use of one or more practices, means, methods, operations, or processes, reasonably necessary or appropriate to provide safe or healthful employment or places of employment" (29 U.S.C. 652(8)).

A standard is reasonably necessary or appropriate within the meaning of section 3(8) of the OSH Act if it materially reduces a significant risk to workers; is economically feasible; is technologically feasible; is cost effective; is consistent with prior Agency action or is a justified departure; adequately responds to any contrary evidence and argument in the

rulemaking record; and effectuates the Act's purposes at least as well as any national consensus standard it supersedes (see 29 U.S.C. 652; 58 FR 16612, 16616 (3/30/1993)).

A standard is technologically feasible if the protective measures it requires already exist, can be brought into existence with available technology, or can be created with technology that can reasonably be expected to be developed (*Pub. Citizen Health Research Group v. U.S. Dep't of Labor*, 557 F.3d 165, 170–71 (3d Cir. 2009); *Am. Iron and Steel Inst. v. OSHA (Lead II)*, 939 F.2d 975, 980 (D.C. Cir. 1991); *United Steelworkers of Am., AFL-CIO-CLC v. Marshall*, 647 F.2d 1189, 1272 (D.C. Cir. 1980)).

A standard is economically feasible if industry can absorb or pass on the cost of compliance without threatening its long-term profitability or competitive structure (*Am. Textile Mfrs. Inst. v. Donovan (Cotton Dust)*, 452 U.S. 490, 530 n.55 (1981); *Lead II*, 939 F.2d at 980). A standard is cost effective if the protective measures it requires are the least costly of the available alternatives that achieve the same level of protection (*Int'l Union, United Auto., Aerospace & Agric. Implement Workers of Am., UAW v. OSHA (Lockout/Tagout II)*, 37 F.3d 665, 668 (D.C. Cir. 1994). See also *Cotton Dust*, 452 U.S. at 514 n.32 (suggesting that the "reasonably necessary or appropriate" language of Section 3(8) of the Act (29 U.S.C. 652(8)) might require OSHA to select the less expensive of two equally effective measures)).

Section 6(b)(7) of the OSH Act authorizes OSHA to include among a standard's requirements labeling, monitoring, medical testing, and other information-gathering and transmittal provisions (29 U.S.C. 655(b)(7)).

All safety standards must be highly protective (see 58 FR at 16614–16615; *Lockout/Tagout II*, 37 F.3d at 668). Finally, whenever practicable, standards shall "be expressed in terms of objective criteria and of the performance desired" (29 U.S.C. 655(b)(5)).

IV. Summary and Explanation of the Final Rule

The final rule revises and updates the requirements in the general industry Walking-Working Surfaces standards (29 CFR part 1910, subpart D), including requirements for ladders, stairs, dockboards, and fall and falling object protection; and it adds new requirements on the design, performance, and use of personal fall protection systems (29 CFR part 1910, subpart I). The final rule also makes conforming changes to other standards

in part 1910 that reference requirements in subparts D and I.

A. Final Subpart D

This part of the preamble discusses the individual requirements in the specific sections of final subpart D; explains the need for and purposes of the requirements; and identifies the data, evidence, and reasons supporting them. This preamble section also discusses issues raised in the proposed rule and by stakeholders, significant comments and testimony submitted to the rulemaking record, and substantive changes from the proposed rule.

In accordance with section 6(b)(8) of the OSH Act, OSHA drew many of the revisions, new provisions, and technological advancements in the proposed and final rules from various national consensus standards. In the discussion of the specific sections of final subpart D, OSHA identifies the national consensus standards that section references. In the summary and explanation of the proposed rule, OSHA's references to national consensus standards are to the editions that were current at that time. In the time since OSHA published the proposed rule, many of the referenced consensus standards have been revised and updated. In the final preamble, OSHA references the most recent editions of those national consensus standards, where appropriate, after examining and verifying that they are as protective as earlier editions.

OSHA has taken a number of steps in the final rule, like the proposal, to provide greater compliance flexibility for employers and make the final rule easier to understand and follow, which stakeholders supported (e.g., Exs. 155; 164; 165; 172; 191; 196; 202). For example, consistent with section 6(b)(5) of the Occupational Safety and Health Act of 1970 (29 U.S.C. 655(b)(5)), the final rule uses performance-based language in place of specification requirements, which gives employers flexibility to select the controls that they determine to be most effective for the particular workplace situation and operation. Like the proposed rule, OSHA increases "harmonization" between the final rule and OSHA construction standards (29 CFR part 1926, subparts L, M, and X), which makes compliance easier for employers who perform both general industry and construction operations (e.g., Exs. 164; 165; 172; 191; 202; 226).

Finally, clarifying provisions and terms, using plain language, and consolidating and reorganizing the requirements also make the final rule easier to understand, thereby, enhancing

compliance. The following table lists the sections in final subpart D and the corresponding sections in the existing subpart:

Final Subpart D	Existing Subpart D
§1910.21 Scope and definitions.	§1910.21 Definitions.
§1910.22 General requirements.	§1910.22 General requirements.
§1910.23 Ladders.	§1910.23 Guarding floor and wall openings and holes.
§1910.24 Step bolts and manhole steps.	§1910.24 Fixed industrial stairs.
§1910.25 Stairways.	§1910.25 Portable wood ladders.
§1910.26 Dockboards.	§1910.26 Portable metal ladders.
§1910.27 Scaffolds and rope descent systems.	§1910.27 Fixed ladders.
§1910.28 Duty to have fall protection and falling object protection.	§1910.28 Safety requirements for scaffolding.
§1910.29 Fall protection systems and falling object protection—criteria and practices.	§1910.29 Manually propelled mobile ladder stands and scaffolds (towers).
§1910.30 Training requirements.	§1910.30 Other working surfaces.

Section 1910.21—Scope and Definitions

Final § 1910.21 establishes the scope of and defines the terms used in 29 CFR part 1910, subpart D—Walking-Working Surfaces.

Final Paragraph (a)—Scope

Final paragraph (a), like the proposed rule, specifies that the subpart applies to all general industry workplaces. It covers all walking-working surfaces unless specifically excluded by an individual section of this subpart. The final rule consolidates the scope requirements for subpart D into one provision and specifies that the final rule applies to all walking-working surfaces in general industry workplaces.

The final rule defines “walking-working surfaces” as any surface on or through which an employee walks, works, or gains access to a work area or workplace location (§ 1910.21(b)). Walking-working surfaces include, but are not limited to, floors, ladders, stairways, steps, roofs, ramps, runways, aisles, scaffolds, dockboards, and step bolts. Walking-working surfaces include horizontal, vertical, and inclined or angled surfaces.

Final paragraph (a) also specifies that subpart D does not apply to general industry walking-working surfaces, including operations and activities occurring on those surfaces, that an individual section or provision

specifically excludes. Final subpart D addresses each of these specific exclusions in the relevant individual section or provision. OSHA notes that each exclusion only applies to the specific section or provision in which it appears and not to any other final subpart D section or provision. Existing subpart D does not have a single scope provision that applies to the entire subpart. Rather, it includes separate scope requirements in various sections in the subpart (e.g., § 1910.22—General requirements; § 1910.24(a)—Fixed industrial stairs; § 1910.25(a)—Portable wood ladders; § 1910.27(e)(3)—Fixed ladders; § 1910.29(a)(1)—Manually

propelled mobile ladder stands and scaffolds (towers)).

OSHA believes the consolidated scope provision in final paragraph (a) is clearer and easier to understand than the existing rule. Final paragraph (a) allows employers to determine more easily whether the final rule applies to their particular operations and activities. In addition, the final rule is consistent with OSHA's interpretation and enforcement of subpart D since the Agency adopted the walking-working surfaces standards in 1971. It also is consistent with other OSHA standards, including Agency construction standards (e.g., 29 CFR 1926.450(a); 1926.500(a); 1926.1050(a)).

A number of stakeholders commented on the proposed scope provision (e.g., Exs. 73; 96; 109; 187; 189; 190; 198; 201; 202; 251; 254; 323; 340; 370). Some stakeholders urged OSHA to expand the scope to include agricultural operations (Exs. 201; 323; 325; 329 (1/18/2011, pgs. 206–08); 329 (1/19/2011, p. 101); 340; 370). Most commenters, however, recommended that OSHA limit the scope or exclude certain workers, work operations, or walking-working surfaces or hazards, such as inspection, investigation, and assessment activities; public safety employees; rolling stock and motor vehicles; and combustible dust (e.g., Exs. 73; 96; 98; 150; 156; 158; 157; 161; 167; 173; 187; 189; 190; 202). (See separate discussions of agricultural operations and rolling stock and motor vehicles below. See final § 1910.22(a) for discussion of combustible dust.)

Verallia commented that the proposed scope, combined with the proposed definition of “walking-working surfaces” (§ 1910.21(b)), “greatly expands the obligation of employers” and makes some requirements, such as regular inspections, “unduly burdensome” (Ex. 171). Verallia recommended that OSHA limit the scope of the final rule by revising the walking-working surfaces definition (see discussion of the definition of walking-working surfaces in final § 1910.21(b)). OSHA disagrees with Verallia's contention. The existing rule covers all of the examples of walking-working surfaces listed in the proposed definition of walking-working surfaces (proposed § 1910.21(b)).

Several stakeholders urged that OSHA exclude inspection, investigation, and assessment operations performed before the start of work and after work is completed (e.g., Exs. 109; 156; 157; 177; 254). While some of these commenters recommended excluding those operations from fall protection requirements, others said OSHA should add to final § 1910.21(a) the following

language from OSHA's construction standard (29 CFR 1926.500(a)(1)):

Exception: The provisions of this subpart do not apply when employees are making an inspection, investigation, or assessment of workplace conditions prior to the actual start of construction work or after all construction work has been completed.

Such language would have the effect of excluding these operations from the entirety of subpart D, which OSHA opposes. Although OSHA excludes these operations from the fall protection requirements in final § 1910.28 (see discussion in final § 1910.28(a)(2)), employers performing them must comply with the other requirements in this subpart. For example, those employers must ensure that ladders and stairways their workers use to get to the workplace location are safe; that is, are in compliance with the requirements in final § 1910.23 and final § 1910.25, respectively. Employers also must ensure that the workers performing those operations can safely perform those operations by ensuring they receive the training that final § 1910.30 requires.

Some stakeholders recommended that OSHA exclude public safety employees from the final rule (Exs. 167; 337; 368). The Public Risk Management Association (PRIMA) offered three reasons for excluding public safety employees from the final rule. First, they said employers do not control the walking-working surfaces where employees perform public safety and emergency response operations (Ex. 167). Second, they said it is “unreasonable” to require public safety employees (e.g., SWAT teams) to install and use fall protection systems, since there is only a short time in which emergency response and rescue operations they perform will be effective. Finally, PRIMA said requiring that State Plan States adopt the final rule or an equivalent could result in different rules that could adversely impact interstate multidisciplinary teams and agreements.

OSHA does not believe excluding public safety employees from the entire final rule is appropriate or necessary. Many general industry employers that the final rule covers perform operations on walking-working surfaces that they do not own, thus, in this respect, public safety employers and operations are not unique. Regardless of whether general industry employers own the walking-working surfaces where their workers walk and work, they still must ensure the surfaces are safe for them to use. For example, general industry employers, including public safety employers, must

ensure that the walking-working surfaces are able to support their employees as well as the equipment they use. If walking-working surfaces cannot support the maximum intended load, employees and, in the case of public safety employers, the people they are trying to assist or rescue, may be injured or killed.

OSHA does not believe stakeholders provided convincing evidence showing this and other requirements (e.g., training) provisions in final subpart D are not feasible for public safety employers. However, if an employer, including public safety employers, can demonstrate that it is infeasible or creates a greater hazard to comply with the final rule in a particular situation, they may use other reasonable alternative means to protect their employees. (OSHA notes that final § 1910.23 does not apply to ladders that employers use in emergency operations such as firefighting, rescue, and tactical law enforcement operations (see discussion in final § 1910.23(a)(1)).)

Agricultural operations. The final rule, like the proposal, covers walking-working surfaces in general industry workplaces. In the preamble to the proposed rule OSHA clearly specifies that the proposal does not apply to agricultural operations; 29 CFR part 1928 covers those operations (75 FR 28920 (5/24/2010)).

Although neither the proposed rule nor OSHA standards define “agricultural operations,” the Agency has said they generally include “any activities involved in the growing and harvesting of crops, plants, vines, fruit trees, nut trees, ornamental plants, egg production, the raising of livestock (including poultry and fish) and livestock products” (e.g., feed for livestock on the farm) (Field Operations Manual (FOM), Chapter 10, Section B(1)). Agricultural operations include preparation of the ground, sowing, watering and feeding of plants, weeding, spraying, harvesting, raising of livestock, and “all activity necessary for these operations” (Memorandum from Patricia Clark, Directorate of Compliance Programs (7/22/1992)).

OSHA's Appropriations Act uses the term “farming operations,” which is similarly defined as “any operation involved in the growing or harvesting of crops, the raising of livestock or poultry, or related activities conducted by a farmer on sites such as farms, ranches, orchards, dairy farms or similar farming operations” (CPL 02–00–51; 42 FR 5356 (1/28/1977); Memorandum for Regional

Administrators (7/29/2014)).³ Farming operations on small farms also include “preparing the ground, sowing seeds, watering, weeding, spraying, harvesting, and all related activities necessary for these operations, such as storing, fumigating, and drying crops grown on the farm” (Memorandum for Regional Administrators (7/29/2014)).

The Occupational Safety and Health Review Commission (OSHRC) has ruled that activities integrally related to these core agricultural operations also are agricultural operations (*Darragh Company*, 9 BNA OSHC 1205, 1208 (1980) (delivery of chicken feed to farmers that raise chickens is integrally related to agricultural operations)). Determining whether an activity is a core agricultural operation must be made on a case-by-case basis and be based on the nature and character of the specific activity rather than the employer’s agricultural operation as a whole (*J.C. Watson Company*, 22 BNA OSHC 1235, 1238, *aff’d*, 321 Fed. Appx. 9 (April 17, 2009)).

Under the *Darragh* test, post-harvesting activities are not integral to core agricultural operations, therefore, they are not covered by part 1928 (*J.C. Watson Company*, 22 BNA OSHC 1235 (2008)). Post-harvest activities such as receiving, cleaning, sorting, sizing, weighing, inspecting, stacking, packaging and shipping produce are not “agricultural operations” (*J.C. Watson Company*, 22 BNA OSHC at 1238 (employer’s packaging of onions (1) grown on land employer owned, leased, or worked; (2) purchased on the “spot market”; or (3) brought to the shed by other growers; in a shed on the employer’s farm was “not integral to the growing of onions, the true agricultural operation here”). Post-harvesting activities not on a farm include the processing of agriculture products, which “can be thought of as changing the character of the product (canning, making cider or sauces, etc.) or a higher degree of packaging versus field sorting in a shed for size” (FOM, Chapter 10, Section B(4)).

In addition, activities performed on a farm that “are not related to farming operations and are not necessary to gain economic value from products produced on the farm” are general industry activities (Memorandum for Regional Administrators (July 29, 2014) (these

activities on a small farm “are not exempt from OSHA enforcement” under the appropriations rider)). To illustrate, the memorandum specifies the following activities performed on a farm are general industry activities (“food manufacturing operations”) not farming operations exempt under the appropriations rider:

- Grain handling operation that stores and sells grain grown on other farms;
- Food processing facility that makes cider from apples grown on the farm or processes large carrots into “baby carrots;” and
- Grain milling facility and use of milled flour to make baked goods.

As mentioned, a number of stakeholders urged that OSHA include agricultural operations in the final rule for several reasons (Exs. 201; 323; 325; 340; 370). First, the stakeholders said fall hazards are present throughout agricultural operations. For instance, Farmworker Justice stated:

Fall hazards exist in all types of farm operations in both crop and animal production, including work in vegetable fields, packing sheds, fruit orchards, tree nurseries, greenhouses, mushroom houses, dairies, poultry farms, cattle feedlots, and other livestock operations (Ex. 325).

They also said that workers are exposed to fall hazards while working on various types of walking-working surfaces, including ladders, farm machinery, and elevated farm structures (Ex. 325).

Second, stakeholders said fall hazards are a leading cause of worker fatalities and injuries in agricultural operations. Farmworker Justice said the annual number of fatal falls in agricultural operations accounted for almost 10 percent of all annual occupational fatal falls (Ex. 370). They said a NIOSH analysis of 2005 Bureau of Labor Statistics (BLS) data indicated that fall-related farmworker deaths occurred at a rate of 1.4 per 100,000, “a rate exceeded in only two other industries: Construction . . . and mining” (Ex. 325, referring to 2005 Census of Fatal Occupational Injury data). According to Farmworkers Justice, BLS data from 2004–2009 indicated that 157 agricultural workers died due to falls, which they said was an average of over 28 fall deaths per year (Exs. 329 (1/18/2011, pp. 228); 370). California Rural Legal Assistance Foundation (CRLAF) said BLS fatality data from 1992–1997 indicated 166 agricultural workers died as a result of falls from elevations (Ex. 201).

Farmworker Justice and CRLAF also submitted evidence on the prevalence of fall injuries in agricultural operations. CRLAF said an analysis of 1991 Florida

worker compensation records in agricultural operations revealed that falls accounted for nearly 25 percent of all serious, disabling work injuries (Ex. 201). Farmworker Justice reported:

BLS data indicates that workers in both crop and animal production had among the highest rates of non-fatal fall-related injuries requiring days away from work of all U.S. workers in 2009 (Ex. 370).

Farmworker Justice stated that fall injuries were particularly frequent among workers harvesting tree fruit and nut crops:

According to 2009 BLS fall injury data . . . orchard workers suffered ladder-related fall injuries at the rate of 33.6 per 10,000 workers, which would be among the top 20 industry fall rates examined by OSHA (Ex. 370; *see also* Ex. 325).

CRLAF reported similar data showing “nearly one-third (31%) of the 13,068 Workers’ Compensation Claims in Washington State orchards between 1996 and 2001 involving compensation for lost work time were for ladder related injuries.”

Third, stakeholders said the fall protection standards that California, Oregon, and Washington have adopted to protect agricultural workers show that it is feasible to apply the final rule to agriculture operations (Exs. 325; 329 (1/18/2011, pgs. 207–210); 340; 370). Farmworker Justice said that government officials, agricultural orchard employers, and agricultural safety training experts in these states indicated that compliance with those standards have “significantly reduced injuries among agricultural workers” (Ex. 370). It also reported that a Washington study of fall injuries among orchard workers over a five-year period (1996–2001) following implementation of the state’s fall protection standard found “statistically significant annual reductions in injuries” (Ex. 370, discussing Hofmann J, Snyder K, Keifer M. “A descriptive study of workers claims in Washington State orchards,” 56 Occupational Medicine 251–257 (2006)).

OSHA agrees with the stakeholders that walking-working surface hazards, particularly fall hazards, exist in agricultural operations. That said, OSHA has not included agricultural operation in the final rule. The Agency has not gathered and analyzed the type of information on agricultural operations necessary to support a rule. OSHA has not gathered and analyzed information on the number of agricultural workers and establishments the final rule would affect. In addition, OSHA has not determined what percentage of agricultural

³ Since 1976, a Congressional appropriations rider has precluded OSHA from expending funds to conduct enforcement activities with respect to any person engaged in farming operations with 10 or fewer non-family employees that has not maintained a temporary labor camp within the preceding 12 months (Consolidated Appropriations Act, 2014, Pub. L. No. 113–76 (2014)).

establishments are farming operations with 10 or fewer non-family employees that have not maintained a temporary labor camp within the preceding 12 months and therefore exempt from enforcement of the final rule.

OSHA has not gathered and analyzed data and information on the jobs in agricultural operations where walking-working surface hazards are present and worker injuries and fatalities are occurring; the current employer practices to address these hazards; and the availability and cost of controls, such as fall protection systems, to protect workers from those hazards. In addition, OSHA has not conducted the economic and regulatory flexibility analyses necessary to make a feasibility determination. And, because the proposal clearly did not extend to agricultural operations, the public has not had a chance to comment on those issues. These and other steps are necessary before OSHA can issue a final rule that applies to agricultural operations. As such, the final rule applies to general industry and not agricultural operations. However, if an operation performed on a farm is not an "agricultural operation" or integrally related to an agricultural operation, such as a food manufacturing or other post-harvesting operations, then the final general industry rule applies.

Rolling stock and motor vehicles. In this rulemaking OSHA has raised issues and requested comment about whether the final rule should include specific requirements to protect workers from falling off rolling stock and motor vehicles.⁴ The 2010 proposal does not include specific requirements for rolling stock and motor vehicles (75 FR 28862). Instead, in the preamble, OSHA said it would continue gathering information and evidence to determine whether there is a need to propose specific requirements for rolling stock and motor vehicles (75 FR 28867). OSHA also said it needs "more information about what employers are presently doing and any feasibility and cost concerns associated with a requirement to provide protection" for rolling stock and motor vehicles. OSHA said it will wait until the record is more fully developed to make a determination about requiring fall protection on rolling stock and motor vehicles. OSHA also stated that if it receives sufficient comments and evidence to warrant additional

rulemaking on rolling stock and motor vehicles, the Agency will issue "a separate proposed rule" (75 FR 28867) (emphasis in original). The comments the Agency received on the need for specific requirements for rolling stock and motor vehicles are summarized below.

Many stakeholders support adding specific fall protection requirements for rolling stock and motor vehicles to the final rule (e.g., Exs. 127; 130; 155; 185; 198; 257; 307; OSHA-S029-2006-0662-0195; OSHA-S029-2006-0662-0196; OSHA-S029-2006-0662-0207; OSHA-S029-2006-0662-0227; OSHA-S029-2006-0662-0234; OSHA-S029-2006-0662-0247; OSHA-S029-2006-0662-0310; OSHA-S029-2006-0662-0329), while many urge OSHA to exclude rolling stock and motor vehicles from coverage or to limit fall protection requirements to specific situations, such as when vehicles are inside or contiguous to a building (e.g., Exs. 63, 121; 158; 161; 162; 181; 182; 183; 220; 238; 335; OSHA-S029-2006-0662-0202; OSHA-S029-2006-0662-0219; OSHA-S029-2006-0662-0226; OSHA-S029-2006-0662-0229; OSHA-S029-2006-0662-0244; OSHA-S029-2006-0662-0252; OSHA-S029-2006-0662-0302; OSHA-S029-2006-0662-0306; OSHA-S029-2006-0662-0314; OSHA-S029-2006-0662-0320; OSHA-S029-2006-0662-0324).

Stakeholders who support adding specific fall protection requirements said workers are exposed to fall hazards working on rolling stock and motor vehicles; falls from rolling stock and motor vehicles have resulted in death and serious injury; and feasible, effective fall protection systems exist and are in use to protect employees working on rolling stock and motor vehicles. These stakeholders include safety professional organizations (e.g., American Society of Safety Engineers (ASSE)); fall protection system manufacturers, suppliers, and installers; safety engineers and consultants; and labor organizations.

Stakeholders who oppose adding specific requirements said requiring fall protection for rolling stock and motor vehicles is not necessary, creates a greater hazard, and is infeasible. Some said OSHA did not have authority to regulate rolling stock and motor vehicles, and, in any event, should leave such regulation to the Federal Railroad Administration (FRA) and Federal Motor Carrier Safety Administration (FMCSA), respectively. Some stakeholders urged OSHA that the final rule limit fall protection requirements to vehicles located inside or contiguous to a building or structure. These

stakeholders include employers, small businesses, and industry associations (Exs. 182; 220; OSHA-S029-2006-0662-0226; OSHA-S029-2006-0662-0229; OSHA-S029-2006-0662-0231; OSHA-S029-2006-0662-0237; OSHA-S029-2006-0662-0252; OSHA-S029-2006-0662-0306; OSHA-S029-2006-0662-0340).

Need for fall protection. Several stakeholders asserted that fall protection on rolling stock and motor vehicles is not necessary for a variety of reasons. First, stakeholders said no or very few workers climb on rolling stock and motor vehicles (Exs. 124; 183; 187; 220; 238). For example, Minnesota Grain and Feed Association (MGFA) said members load/unload rolling stock and motor vehicles using electronic controls operated from ground-level instead (Ex. 220). Likewise, the Small Business Administration Office of Advocacy (SBA Advocacy) and American Trucking Associations (ATA) said employees load/unload truck trailers through the rear door directly to docks, ramps, and other devices (Exs. 124; 187; 190; 220). Stakeholders who said workers climb on rolling stock and motor vehicles stressed the number of workers doing so is very low. Conoco Phillips Company said, "[T]he number of employees required to work atop rolling stock is minimal (<1%)" (Ex. OSHA-S029-2006-0662-0320; see also Exs. 148 (NGFA—"At best, a small percentage of the employees . . . are exposed"); 181 (American Truck Dealers/National Automobile Dealers Association (ATD/NADA)—less than 10 percent of employees)).

Other stakeholders, however, including some who oppose requiring fall protection, said a significant number/percentage of employees must climb on or access the tops of rolling stock and motor vehicles to perform a wide range of tasks, including loading/unloading, tarping, maintenance and repair, inspections, sampling, snow and ice removal, and other tasks (e.g., Exs. 63; 121; 158; OSHA-S029-2006-0662-0350). For instance, Clear Channel Outdoors (CCO) said that nearly 80 percent of their field employees climb on motor vehicles (Ex. 121). Ferro Corporation estimated that almost one-half of employees at a typical plant climb onto the top of rolling stock and bulk trucks to perform tasks (Ex. OSHA-S029-2006-0662-0177).

Second, a number of stakeholders stated that fall protection is not necessary on rolling stock and motor vehicles because worker exposure to fall hazards is limited. Several stakeholders said exposure is "infrequent," "brief and sporadic" (Exs. 124; 181; 183; 187;

⁴ OSHA defines "rolling stock" as any locomotive, railcar, or vehicle operated exclusively on a rail or rails, or a trolley bus operated by electric power supplied from an overhead wire. "Motor vehicle" means any commercial bus, van, or truck, including tractor trailer, flatbed, tanker, and hopper trucks.

OSHA-S029-2006-0662-0124; OSHA-S029-2006-0662-0183; OSHA-S029-2006-0662-0237). Other stakeholders maintain exposure to fall hazards on rolling stock and motor vehicles is more frequent and widespread. For example, Dynamic Scientific Controls (DSC) said fall hazards are present “daily in almost every plant that receives and ships” products (Ex. OSHA-S029-2006-0662-0227; *see also* Exs. 307; 329 (1/20/2011, p. 142)).

Third, some stakeholders assert fall protection is not necessary on rolling stock and motor vehicles because the heights employees climb do not pose fall hazards. For instance, ATA said the height of most commercial vehicle trailers is no more than 49 to 50 inches (*e.g.*, “step-downs” and “low boys”), which only nominally exceeds the 4-foot trigger (Ex. 187). Other stakeholders, however, reported that workers must climb significantly higher than 50 inches on motor vehicles, particularly tanker and hopper trucks, to perform tasks, some of which are the tasks they perform most frequently (*e.g.*, Exs. 130; 198; 307; OSHA-S029-2006-0662-0208). Even where workers only climb 49 to 50 inches onto a trailer or flatbed truck, some stakeholders said there is a risk of serious injury from falls (Exs. 63; 302; 329 (1/20/2011, pgs. 156–60)).

Fourth, a number of stakeholders said fall protection is not necessary because no or few injuries from falls off rolling stock and motor vehicles have occurred in their establishments or industry (Exs. 63; 121; 148; 162; 181; 237; OSHA-S029-2006-0662-0219; OSHA-S029-2006-0662-0237; OSHA-S029-2006-0662-0252; OSHA-S029-2006-0662-0320). Douglas Greenhaus, with ATD/NADA, said:

I’ve spent over twenty-five years working with truck dealerships on matters involving employee health and safety. In that time, I have only rarely heard of injuries arising from falls from commercial trucks, tractors, or trailers (Ex. 181. *See also*, OSHA-S029-2006-0662-0237).

The Cargo Tank Risk Management Committee (CTRMC) stated:

While falls from the top of tank trailers can result in serious injury, the actual frequency of such injuries is very rare. A typical large cargo tank motor vehicle fleet makes over 300 deliveries per day and has averaged less than 2 falls from its tank trailers per year (Ex. 63).

Stakeholders pointed out that industry surveys also show falls from rolling stock and motor vehicles were low. McNeilus Trucking reported that a 2002 Illinois Ready Mix Concrete Association survey found only two falls from ready-mix concrete trucks

occurred in over 66 million climbs (Ex. OSHA-S029-2006-0662-0219). According to an International Liquid Terminals Association’s (ILTA) 2010 annual survey, six of the 221 (2.7%) injuries were falls from rolling stock and motor vehicles, which “represent a very small proportion of the total number of recordable incidents” (Ex. 335). A NGFA survey of 901 facilities showed that during a two-year period (2007–09), during which the facilities handled 1.5 million railcars and 1.4 million motor vehicles, no fatalities and only 12 injuries occurred (Ex. 148).

By contrast, a number of stakeholders said falls from rolling stock and motor vehicles are a serious problem that have resulted in worker deaths and serious injuries (*e.g.*, Exs. 130; 155; 257; 302; 307; 329 (1/20/2011, pgs. 142, 150, 151–152, 156–57); 335; 355–11; OSHA-S029-2006-0662-0207). In the rail transportation industry, Fall Protection Systems Corp. (FPS) reported that they documented, based on site visits and speaking to customers, more than 50 falls in a 10-year period, 14 of which resulted in death and 30 in serious injuries.

Stakeholders reported a similar experience in the truck transportation industry. For example, Rick Hunter, of the Alabama Trucking Association Workers Compensation Fund, said:

Each year drivers and shop [technicians] are injured from falls from tankers and flatbed trailers. I know of 4 deaths from this type fall in Alabama” (Ex. 257).

Cameron Baker, with Standfast USA, testified that one truck company with more than 900 drivers, reported an average of 31 falls per year during a nine-year period (1998–2006) (Exs. 329 (1/20/2011, pgs. 151–52); 355–11). He estimated that the total cost to the company for those fall injuries was \$3.33 million (Ex. 355–11). Standfast also submitted information indicating that rolling stock and motor vehicle fall injuries are increasing (Ex. 355–11).

Fifth and finally, a number of stakeholders said employers already are using effective measures to protect workers on rolling stock and motor vehicles and requiring additional measures in the final rule will not increase worker safety (*e.g.*, Exs. 63; 121; 124; 142; 147; 148; 158; 162; 169; 181; 190; 335). The measures these stakeholders are using include:

- Conventional fall protection system such as cable line and retractable lifeline systems; work platforms with railings/guardrails; walkways with railings; and portable access systems with railings or safety cages; ladders

with railings (Exs. 63; 124; 148; 158; 162; 169; 181; 335);

- Anti-slip surfaces on motor vehicle walkways (Ex. 158);

- Initial, periodic, and remedial training, which is the only measure some stakeholders use (*e.g.*, Exs. 63; 121; 124; 142; 148; 158; 162; 169; 181; 190);

- Work practices such as site-specific loading/unloading protocols and safe climbing techniques (*e.g.*, 3-point climbing); and loading/unloading trailers from the ground (*e.g.*, bottom-loading tankers, ground-level controls) (Ex. 148; 158; 181; 192; 326; 335; OSHA-S029-2006-0662-0314); and

- Administrative controls, including “blue-flagging” rail cars on isolated tracks to prevent moving while employees are on them, prohibiting workers from being on moving rolling stock, and keeping employees off railcars in unsafe weather conditions (*e.g.*, ice, sleet, high winds) (*e.g.*, Ex. 148).

However, as mentioned, other stakeholders believe requiring fall protection on rolling stock and motor vehicles is necessary because many employers have not implemented readily available controls even though their workers are exposed to fall hazards on rolling stock and motor vehicles and fall injuries and fatalities are occurring in the railroad and truck transportation industries (*e.g.*, Exs. 127; 130; 155; 185; 198; 257; 307; OSHA-S029-2006-0662-0195; OSHA-S029-2006-0662-0196; OSHA-S029-2006-0662-0207; OSHA-S029-2006-0662-0227; OSHA-S029-2006-0662-0234; OSHA-S029-2006-0662-0247; OSHA-S029-2006-0662-0310; OSHA-S029-2006-0662-0329). FPS, for instance, pointed out that the lost-workday injury rates due to falls from elevations in the rail transportation and truck transportation industries are 25.9 and 29.1 lost workdays per 10,000 employees, respectively (Ex. 130).

Greater hazard. Several stakeholders oppose requiring fall protection on rolling stock and motor vehicles because they say it would expose workers to a “greater hazard” than working without any protection (Exs. 121; 124; 181; OSHA-S029-2006-0662-0219; OSHA-S029-2006-0662-0232; OSHA-S029-2006-0662-0244). To establish that an OSHA standard creates a greater hazard, an employer must prove, among other things, that the hazards of complying with the standard are greater than those of not complying, and alternative means of employee protection are not available (*Bancker Construction Corp., v. Reich*, 31 F.2d 32, 34 (2d Cir. 1994); *Dole v. Williams Enterprises, Inc.*, 876 F.2d 186, 188 (D.C. Cir. 1989)). The Occupational

Safety and Health Review Commission has held that the employer must establish that complying with a standard would be more dangerous than allowing employees to work without compliance (*Secretary of Labor v. Spancrete Northeast, Inc.*, 16 BNA OSHC 1616, *aff.* 40 F.3d 1237 (2d Cir. 1994)).

Stakeholders said that requiring personal fall protection systems on rolling stock and motor vehicles could create a greater risk by causing “entanglement with moving parts” (Ex. 124) and creating trip hazards (Exs. 181; OSHA-S029-2006-0662-0244). They also said requiring workers “to continually tie and untie from a variety of anchorage points when the employee accesses and moves around” rolling stock or motor vehicles also could create a greater hazard (Ex. 121; OSHA-S029-2006-0662-0244). Keller and Heckman explained:

[T]he worker would first have to climb or otherwise travel to the anchorage location to attach and then detach from the anchorage, which might very well pose a greater hazard than simply working carefully without fall protection (Ex. OSHA-S029-2006-0662-0244).

However, these stakeholders did not identify instances in which workers were injured while using personal fall protection systems on rolling stock and motor vehicles.

Also, these stakeholders did not show that there are no alternative fall protection measures or systems available to protect workers. In fact, these and other stakeholders identified various types of fall protection systems that they and other employers are using successfully to protect employees working on rolling stock and motor vehicles (e.g., Exs. 63; 124; 130; 148; 158; 162; 181; 185; 198; 307; 335; OSHA-S029-2006-0662-0207; OSHA-S029-2006-0662-0208). In point, although ATD/NADA asserted that requiring fall protection on rolling stock and motor vehicles would create a greater hazard, they also said:

Dealerships often use railing-equipped metal stairs with lockable casters or other ladder systems to reach the sides and tops of trucks, tractors, or trailers, thereby reducing the need to climb on the vehicles themselves. When and where used, mobile work platforms and scaffolds have adjustable ‘maximum’ heights and are equipped with side rails and toe boards to prevent falling or tripping from the top section. . . . Paint booths often have mobile or stationary stair platforms equipped with railings and safety chains (Ex. 181).

Technological feasibility. As discussed in Pertinent Legal Authority (Section III), OSHA must prove, by

substantial evidence in the rulemaking record that its standards are technologically and economically feasible, which the Supreme Court has defined as “capable of being done, executed, or effected” (*American Textile Mfrs. Inst. v. Donovan (Cotton Dust)*, 452 U.S. 490, 506 n. 25 (1981)). A standard is technologically feasible if the protective measures it requires already exist, can be brought into existence with available technology, or can be created with technology that can reasonably be expected to be developed (*Cotton Dust*, 452 U.S. at 513; *United Steelworkers v. Marshall (Lead I)*, 647 F.2d 1189, 1272 (D.C. Cir. 1980), *cert. denied*, 453 U.S. 913 (1981)). OSHA is not bound by the “technological status quo.” The Agency can be “technology-forcing,” that is, giving industry a reasonable amount of time to develop new technologies (*Lead I*, 647 F.2d at 1264).⁵

Stakeholders asserted various reasons why they believe it is not technologically feasible to require fall protection on rolling stock and motor vehicles that are not located in or contiguous to a building or other structure. First, several stakeholders contend that guardrail systems, safety net systems, and personal fall protection system are not feasible in those locations (e.g., Exs. 158; 326; 329 (1/20/2011, pgs. 156–58); OSHA-S029-2006-0662-0314).

Standfast USA said safety net systems are difficult to deploy and guardrail systems either obstruct loading racks or cannot be raised when the racks are present (Ex. 329 (1/20/2011, pgs. 156–58)).

Regarding personal fall protection systems, stakeholders stated there is no place to install anchorage points when rolling stock and motor vehicles are not located in or contiguous to a building or structure (e.g., Exs. 121; 124; 126; 187; 192; 326; OSHA-S029-2006-0662-0237; OSHA-S029-2006-0662-0244), and attaching them to the rolling stock and motor vehicles is not feasible because the personal fall protection system would compromise the strength or structural integrity of the vehicles, which are made of aluminum, which “fatigues over time” (Ex. 158; OSHA-S029-2006-0662-0219).

However, other stakeholders submitted evidence showing that controls are available and in use on

⁵ A determination of feasibility at the time a standard is promulgated establishes a rebuttable presumption of feasibility. Employers subject to an enforcement action can overcome this presumption by demonstrating that the controls or action the standard requires are not feasible for its operation (*Lead I*, 647 F.2d at 1272).

rolling stock and motor vehicles regardless of location (e.g., Exs. 63; 130; 158; 161; 169; 185; 307; 335; OSHA-S029-2006-0662-0207; OSHA-S029-2006-0662-0208; OSHA-S029-2006-0662-0329; OSHA-S029-2006-0662-0350; OSHA-S029-2006-0662-0373). For example, the American Feed Industry Association (AFIA) said members have found guardrail systems (i.e., railed walkways and catwalks; “pop-up”/collapsible handrails) to be “very effective” regardless of where rolling stock and motor vehicles are located (Ex. 158; *see also* Exs. 161; 169; 335; OSHA-S029-2006-0662-0207; OSHA-S029-2006-0662-0208; OSHA-S029-2006-0662-0350; OSHA-S029-2006-0662-0373). In addition, stakeholders submitted evidence showing that personal fall protection systems are available and in use in a broad range of industries, regardless of the location of the rolling stock and motor vehicles (e.g., Exs. 130; 148; 158; 198; 307; 355; OSHA-S029-2006-0662-0208; OSHA-S029-2006-0662-0373). Some of these systems are attached to rolling stock and motor vehicles (e.g., Exs. 307; 355; OSHA-S029-2006-0662-0208), while others are stand-alone or portable, wheel-mounted overhead systems that employers can use in open yards and other locations (e.g., Exs. 148; 158; 198; 355–2; OSHA-S029-2006-0662-0373).

Second, several stakeholders stated that retrofitting rolling stock and motor vehicles with fall protection is not feasible (Exs. 63; 158; 190; 192; 329 (1/20/2011, pgs. 112–13); 335; OSHA-S029-2006-0662-0219). McNeilus Trucking, for instance, said retrofitting could affect the structural integrity or performance of rolling stock and motor vehicles (Ex. OSHA-S029-2006-0662-0219). *See also* Ex. 158). ILTA testified that although fall protection systems “are very routinely part of the initial design” in new equipment, existing rolling stock and motor vehicles “do not have assets that would readily accept a fall protection system”:

It’s not easy to take these piping manifolds and just simply overlay a superstructure in many cases. . . . [W]hen we’re looking at older installations that might require retrofitting where . . . retrofit really does require complete bulldoze and start over” (Ex. 329 (1/20/2011, pgs. 112–13). *See also* Ex. 335).

Other stakeholders, including industry associations, commented that rolling stock and motor vehicles have been retrofitted with fall protection systems (e.g., Exs. 307; 335; 355), and pointed out that there are many other types of portable and stand-alone fall protection systems (e.g., overhead

trolley rail systems) available and in use instead of retrofitting rolling stock and motor vehicles (e.g., Exs. 130; 198; 307; 329 (1/18/2011, pgs. 90–92); 355; OSHA–S029–2006–0662–0207; OSHA–S029–2006–0662–0208; OSHA–S029–2006–0662–0373).

Third, some stakeholders asserted fall protection on rolling stock and motor vehicles is not feasible because of circumstances beyond their control (Exs. 148; 181; 326). These stakeholders said, for example, they cannot install fall protection systems because they do not own the motor vehicles (i.e., leased fleet, belong to customers, are inventory for sale) or rail carriers prohibit them from modifying rolling stock without prior approval. Some stakeholders said FRA and FMCSA requirements prevent them from using fall protection (Exs. 148; 326). For instance, NGFA stated that members cannot install fall protection on rolling stock because of FRA “clearance envelope” requirements (Ex. 148). Similarly, Southeast Transportation Systems (STS) said FMCSA rules on motor vehicle weight, height, width, length, and accessory design (e.g., ladders) “are just some of the factors preventing the use of conventional fall protection systems” (Ex. 326. *See also* Exs. 158; OSHA–S029–2006–0662–0226). AFIA agreed:

Bulk feed transportation equipment must meet maximum height constraints in order to comply with Department of Transportation regulations. The maximum allowable height of trucks and trailers is 13’6”. Since the top of our equipment is approximately 13’ high, the industry is limited in positioning additional structures above this height (Ex. 158).

Other evidence in the record, however, indicates that there are many portable and stand-alone fall protection systems available and in use today in both the rail and truck transportation industries, including overhead cable line systems, moveable stairs with railings, mobile access platforms with railings and/or safety cages and overhead tarping systems (e.g., Exs. 198; 302; 355; OSHA–S029–2006–0662–0350; OSHA–S029–2006–0662–0373). For example, an NGFA survey revealed that nearly 40 percent of their member facilities have installed overhead fall protection systems in railcar loading areas (Ex. 148. *See also* 63; 182; 335). The truck transportation industry has implemented a number of fall protection systems, including portable and adjustable access platforms/racks with railings or safety cages; pedestal platforms; collapsible outer rails; and walkways with collapsible railings (e.g., Exs. 63; 357). Some stakeholders, including truck transportation industry

companies and associations, also pointed to the increasing use of bottom-loading tanks and hoppers, which work even where there are external constraints (e.g., Exs. 63; 158; 329 (1/20/2011, p. 143)).

Fall protection system manufacturers indicated that, based on their experience, “it is feasible and practical to provide workers with active or passive means of fall protection [for working on rolling stock and motor vehicles] in nearly every work situation” (Ex. 329 (1/18/2011, pgs. 82–83); *see also* Exs. 130; 185; 198; 307; 329 (1/18/2011, pgs. 90–92, 164–66); 329 (1/20/2011) pgs. 144, 149–75); 355–2; 355–12; OSHA–S029–2006–0662–0207; OSHA–S029–2006–0662–0208; OSHA–S029–2006–0662–0329; OSHA–S029–2006–0662–0350; OSHA–S029–2006–0662–0373). For example, FPS, which by 2003 already had provided more than 13,000 fall protection systems to the rail and trucking industries, said they have found “no technological or economic obstacles” to prevent employers from providing fall protection equipment for rolling stock and motor vehicles regardless of their location (Ex. 130). For many years, manufacturers have been producing rolling stock and motor vehicle fall protection systems especially designed for use in locations that are not in or contiguous to buildings or other structures (e.g., Exs. 130, 307; 329 (1/18/2011, pgs. 82–83, 90–92); 329 (1/20/2011, pgs. 149–75, 188); 355; OSHA–S029–2006–0662–0208; OSHA–S029–2006–0662–0373). They also have designed, and employers are using, technological advancements that have eliminated the need for workers to climb on rolling stock and motor vehicles (Exs. 302; 329 (1/20/2011, pgs. 144–45, 149–75, 188); 355; OSHA–S029–2006–0662–0207; OSHA–S029–2006–0662–0208; OSHA–S029–2006–0662–0373). These advancements include tanker and hopper trucks that load/unload from the bottom; automated loading/unloading and tarping systems operated by ground-level controls (Exs. 63; 302; 329 (1/20/2011, pg. 143); *see also* Ex. 158). Several industry associations said member companies are increasingly purchasing these new technologies (Exs. 63; 158; 302). Safety and engineering consultants confirmed the ready availability, effectiveness, and feasibility of the new fall protection technologies for rolling stock and motor vehicles (Exs. 227; 251; OSHA–S029–2006–0662–0227; OSHA–S029–2006–0662–0350).

Employers and industry associations submitted information about effective fall protection controls that have been implemented (e.g., Exs. 63; 148; 158;

162; 169; 181; 182; 220; 326; 335; 337; OSHA–S029–2006–0662–0177). For example, Ferro Corporation, which installed cable line systems over rail cars and work platforms with railings on the top of bulk trailers for loading/unloading coatings and other materials reported that they have not experienced any falls since installing the systems in 2000 (Ex. OSHA–S029–2006–0662–0177; *see also* Ex. 329 (1/20/2011, pgs. 149–75)).

As mentioned, AFIA said member companies have installed several types of fall protection systems (e.g., retractable overhead lanyards and harnesses, elevated walkways, “pop-up handrails,” ground-level controls for loading/unloading) that “have proven to be effective”:

[T]he additional couple of minutes to don a full body harness and attach it to a retractable lanyard are insignificant compared to a lost-time accident (Ex. 158).

Industry associations also submitted information showing that a significant portion of their member companies already have installed fall protection systems for rolling stock and motor vehicles (Exs. 63; 148; 158; 162; 169; 181; 182; 220; 335; 357). For example, NGFA reported that nearly 40 percent of all member facilities already have installed overhead fall protection systems in railcar loading areas (Ex. 148). Even “country elevators,” which generally load only one- to three-railcar units, already have installed retractable safety lines and electronic systems operated from ground level (Ex. 148; *see also*, Ex. 220). CTRMC submitted photographs showing fall protection systems already in use on cargo tank trucks in their industry, including tank trucks located “in the field” (Ex. 63).

OSHA believes the evidence employers and industry associations submitted shows it is technologically feasible in many cases for employers to provide fall protection for rolling stock and motor vehicles regardless of their location.

Jurisdiction. Several stakeholders oppose covering rolling stock and motor vehicles in the final rule because they contend that OSHA either lacks authority to require employers to provide fall protection for employees who work on rolling stock and motor vehicles, or should allow the FRA or FMCSA to exercise complete authority for regulating rolling stock and motor vehicles, respectively (Exs. 124; 187; 326; OSHA–S029–2006–0662–0202; OSHA–S029–2006–0662–0232).

Regarding rolling stock, FRA said the Federal Railroad Safety Act (FRSA) grants them broad authority to regulate

railroad safety and they have promulgated regulations to protect railroad employees from falling off of rolling stock (OSHA–S029–2006–0662–0232. *See also* OSHA–S029–2006–0662–0206). Therefore, they contend that Section 4(b)(1) of the OSH Act (29 U.S.C. 653(b)(1))⁶ “displaces OSHA” from regulating rolling stock. FRA also pointed out that its “Railroad Occupational Safety and Health Standards” Policy Statement states that FRA exercises complete authority for “railroad operations,” which is the movement of equipment over the rails. FRA said this authority includes design of “rolling equipment used on a railroad, since working conditions related to such surfaces are regulated by FRA as major aspects of railroad operations” (43 FR 10583, 10587 (3/14/1978)).

In the preamble to the proposed rule, OSHA acknowledged that FRA has authority to regulate “railroad operations” (75 FR 28867). At the same time, OSHA noted that the FRA Policy Statement also recognizes that OSHA has authority for certain “occupational safety and health” issues in the railroad industry:

FRA recognizes that OSHA currently is not precluded from exercising jurisdiction with respect to conditions not rooted in railroad operations nor so closely related to railroad operations as to require regulation by FRA in the interest of controlling predominant operational hazards (43 FR 10587).

Consistent with the Policy Statement, OSHA has authority over working conditions that do not constitute “railroad operations,” such as loading/unloading rolling stock by non-railroad employees off railroad property.

The American Railroad Association (ARA) said OSHA should allow the FRA to exercise authority over rolling stock for two reasons. First, they said rolling stock presents “special concerns, such as clearance issues in rail tunnels and the unique configuration of rolling stock.” Second, they said FRA, not OSHA, has “expertise to determine when regulations [on rolling stock] are necessary and the content of those regulations” (Ex. OSHA–S029–2006–0662–0202). OSHA believes it also has the expertise to address fall hazards on rolling stock. That said, “[i]n the past, FRA and OSHA have closely coordinated their mutual efforts to improve workplace safety in the rail industry” and OSHA “is committed to

continuing working cooperatively” with FRA to maintain and further develop its expertise in rail industry safety (Ex. OSHA–S029–2006–0662–0232).

With regard to commercial motor vehicles, stakeholders asserted that, under Section 4(b)(1), the Motor Carrier Safety Act (MCSA) preempts OSHA from regulating commercial motor vehicles (Exs. 124; 187; 326). The MCSA defines “commercial motor vehicle” as a self-propelled or towed vehicle used on the highways in interstate commerce to transport passengers or property, if the vehicle:

- Has a gross vehicle weight rating or gross vehicle weight of at least 10,001 pounds, whichever is greater;
- Is designed or used to transport more than 8 passengers (including the driver) for compensation;
- Is designed or used to transport more than 15 passengers, including the driver, and is not used to transport passengers for compensation; or
- Is used in transporting material found by the Secretary of Transportation to be hazardous under section 5103 of this title and transported in a quantity requiring placarding under regulations prescribed by the Secretary under section 5103 (49 U.S.C. 31132).

However, as interpreted by the courts and the Occupational Safety and Health Review Commission, section 4(b)(1) does not create an industry-wide exemption. Rather, it preempts OSHA regulation of a particular workplace hazard addressed by the regulation of another agency. Thus, an OSHA standard is preempted by the MCSA only to the extent that the FMCSA has adopted a regulation for commercial motor vehicles addressing the hazard. For example, FMCSA addresses fall hazards for certain commercial motor vehicles in 49 CFR part 399. Since the Agency did not propose any specific fall protection requirements for rolling stock or motor vehicles, OSHA has not included any in this final rule. However, it will continue to consider the comments it has received, and in the future the Agency may determine whether it is appropriate to pursue any action on this issue.

Construction vs. Maintenance. Some stakeholders expressed concerns that OSHA does not clearly delineate what activities are maintenance that the proposed general industry rule covers and what are construction that fall under OSHA’s construction standards (Exs. 124; 150; 196; 202). For example, SBA Advocacy said participants in their small business roundtable were “confused about which standard applies under what circumstances”:

Participants noted that two employees could be working side by side on similar tasks, but one could be covered by the general industry standard and the other by the construction standard. Representatives expressing these concerns included residential construction and remodeling, painting, heating and air conditioning, chimney sweeping, and others (Ex. 124).

In 1994, OSHA clarified the definitions of maintenance v. construction activities:

OSHA’s regulations define construction work as “construction, alteration, and/or repair, including painting and decorating.” They further provide that OSHA’s construction industry standards apply “to every employment and place of employment of every employee engaged in construction work.” . . . In order for work to be construction work, the employer need not itself be a construction company. . . . Further, construction work is not limited to new construction. It includes the repair of existing facilities. The replacement of structures and their components is also considered construction. . . .

There is no specified definition for “maintenance,” nor is there a clear distinction between terms such as “maintenance,” “repair,” or “refurbishment.” “Maintenance activities” can be defined by OSHA as making or keeping a structure, fixture or foundation (substrates) in proper condition in a routine, scheduled, or anticipated fashion. This definition implies “keeping equipment working in its existing state, i.e., preventing its failure or decline.” . . . [D]eterminations of whether [an employer] is engaged in maintenance operations rather than construction activities must be made on a case-by-case basis (Memorandum for Regional Administrators (8/11/1994)).⁷

In subsequent letters of interpretation, OSHA identified factors the Agency considers in determining whether the activity is maintenance or construction and applied them to specific examples (Letter to Randall Tindell (2/1/1999));⁸ Letter to J. Nigel Ellis (5/11/1999));⁹ Letter to Raymond Knobbs (11/18/2003)¹⁰). Those factors include:

- Nature of the work. Equipment reinstalled or replaced with identical equipment is generally maintenance.

⁷ OSHA letter to Regional Administrators is available on OSHA’s Web site at: https://www.osha.gov/pls/oshaweb/owadisp.show_document?p_table=INTERPRETATIONS&p_id=21569.

⁸ OSHA letter to Mr. Tindall is available on OSHA’s Web site at: https://www.osha.gov/pls/oshaweb/owadisp.show_document?p_table=INTERPRETATIONS&p_id=22687.

⁹ OSHA letter to Mr. Ellis is available on OSHA’s Web site at: https://www.osha.gov/pls/oshaweb/owadisp.show_document?p_table=INTERPRETATIONS&p_id=23328.

¹⁰ OSHA letter to Mr. Raymond Knobbs is available on OSHA’s Web site at: https://www.osha.gov/pls/oshaweb/owadisp.show_document?p_table=INTERPRETATIONS&p_id=24789.

⁶ Section 4(b)(1) specifies: Nothing in this chapter shall apply to working conditions of employers with respect to which other Federal agencies . . . exercise statutory authority to prescribe or enforce standards or regulations affecting occupational safety and health (29 U.S.C. 653(b)(1)).

Replacement with improved equipment is construction;

- Whether the work is scheduled. Activity that is an anticipated, routine, and periodic event to keep equipment from degrading and maintain it in its existing state is suggestive of maintenance. As long as the activity continues to be a scheduled activity, the passage of time between the activity, even 10 to 20 years, normally does not alter the characterization of the activity as maintenance;

- The scale and complexity of the activity; which also takes into consideration the amount of time and material required to complete it. Although a project may not necessarily be large in terms of scale, a complex activity in terms of steps involved and tools and equipment needed to complete is likely to be construction; and

- The physical size of the object being worked on. Physical size can be a factor if, because of its size, the process of removal and replacement involves significantly altering the structure or equipment that the object is in. Significant alterations of the structure or equipment will likely be construction.

OSHA believes these factors and examples outlined in the letters of interpretation provide useful guidance to help employers determine whether a particular activity is maintenance or construction. If there is an instance where an employer may not be able to easily classify an activity as maintenance or construction, when measured against the above factors, following the more protective standard will ensure compliance.

In any event, since one of the primary goals of this rulemaking is to harmonize the general industry and construction walking-working surface standards, OSHA believes the distinction between maintenance and construction is of much less significance. As discussed in the introduction to the Summary and Explanation (Section IV), in updating and revising the walking-working surface standards in subpart D and adding new personal fall protection requirements to subpart I, OSHA made requirements consistent with construction standards, where possible. For example, in final §§ 1910.28 and 1910.140, OSHA adopts the flexible approach to providing fall protection systems that the construction standard codified in 1994. Thus, whether performing general industry or construction operations, employers may provide personal fall protection systems to protect their workers. OSHA notes that in the discussion of provisions in subparts D and I the Agency identifies

the corresponding construction standards the final rule incorporates. As a result, OSHA believes that in most cases employers will be able to use the same controls, particularly fall protection systems, and follow the same work practices regardless of whether they are performing general industry or construction activities.

Paragraph (b)—Definitions

Final paragraph (b) defines terms that are applicable to all sections of final subpart D. For the most part, OSHA drew the final definitions from the existing rule (existing § 1910.21(a) through (g)), other OSHA standards (*e.g.*, 29 CFR 1926.450, 1926.500, 1926.1050), and national consensus standards. For example, the Agency adopted several definitions from the construction fall protection standard (§ 1926.500(b)) and revised the language of other definitions to make them consistent with definitions in OSHA construction standards. The Agency also drew a number of definitions from the following national consensus standards, all of which have been revised and updated or issued since OSHA adopted existing § 1910.21(b) in 1971:

- American National Standard Institute (ANSI) A14.1–2007, American National Standard for Safety Requirements for Portable Wood Ladders (ANSI A14.1–2007) (Ex. 376);
- American National Standard Institute (ANSI) A14.2–2007, American National Standard for Safety Requirements for Portable Metal Ladders (ANSI A14.2–2007) (Ex. 377);
- American National Standard Institute (ANSI) A14.3–2008, American National Standard for Ladders—Fixed—Safety Requirements (ANSI A14.3–2008) (Ex. 378);
- American National Standard Institute (ANSI) A14.5–2007, American National Standard for Safety Requirements for Portable Reinforced Plastic Ladders (ANSI A14.5–2007) (Ex. 391);
- American National Standard Institute (ANSI) A14.7–2011, Safety Requirements for Mobile Ladder Stands and Mobile Ladder Stand Platforms (ANSI A14.7–2011) (Ex. 379);
- American National Standard Institute/American Society of Safety Engineers (ANSI/ASSE) A10.18–2012, Safety Requirements for Temporary Roof and Floor Holes, Wall Openings, Stairways, and Other Unprotected Edges in Construction and Demolition Operations (ANSI/ASSE A10.18–2012) (Ex. 388);
- American National Standard Institute/American Society of Safety Engineers (ANSI/ASSE) A10.32–2012,

Fall Protection Systems—American National Standard for Construction and Demolition Operations (Ex. 390);

- American National Standard Institute/American Society of Safety Engineers (ANSI/ASSE) A1264.1–2007, Safety Requirements for Workplace Walking/Working Surfaces and Their Access; Workplace, Floor, Wall and Roof Openings; Stairs and Guardrail Systems (ANSI/ASSE A1264.1–2007) (Ex. 13);

- American National Standard Institute/American Society of Safety Engineers (ANSI/ASSE) Z359.0–2012, Definitions and Nomenclature Used for Fall Protection and Fall Arrest (ANSI/ASSE Z359.0–2012) (Ex. 389);

- American National Standard Institute/International Window Cleaning Association (ANSI/IWCA) I–14.1–2001, Window Cleaning Safety (ANSI/IWCA I–14.1–2001) (Ex. 14);

- American National Standard Institute (ANSI) MH30.2–2005, Portable Dock Leveling Devices: Safety, Performance and Testing (ANSI MH30.2–2005) (Ex. 20);

- National Fire Protection Association (NFPA) 101–2012, Life Safety Code (NFPA 101–2012) (Ex. 385); and

- International Code Council (ICC) International Building Code–2012 (IBC–2012) (Ex. 386).

Final paragraph (b) differs from the existing and proposed rules in several respects. First, the final rule eliminates a number of terms the regulatory text no longer uses. The final rule does not retain the proposed definitions for the following terms because OSHA did not use these terms in final subpart D: “qualified climber,” “safety factor,” and “single-point adjustable suspension scaffold.”

Second, in addition to the definitions in the proposed rule, final paragraph (b) adds a number of new definitions, including “anchorage,” “dangerous equipment,” “low-slope roof,” “personal fall arrest system,” “personal fall protection system,” “positioning system (work-positioning system),” “stairway (stairs),” “travel restraint system,” and “warning line.” Most of the definitions are commonly used terms that pertain to new control methods that the final rule allows employers to use to protect workers from falling. For example, several definitions relate to personal fall protection systems, which the final rule allows employers to use instead of guardrails, cages, and wells specified by the existing rule.

Third, final paragraph (b) revises existing definitions to make them consistent with OSHA’s construction

standards (e.g., §§ 1926.450, 1926.500, 1926.1050). OSHA is aware that many employers and workers perform both general industry and construction activities, and the Agency believes that making the standards, including terminology, consistent will help those employers better understand and fully comply with the final rule.

Fourth, final paragraph (b), like the proposed rule, reorganizes the terms and definitions and clarifies that they are applicable to every section of subpart D. By contrast, the existing rule in § 1910.21 lists the terms and definitions for each section of subpart D separately. Consequently, because the existing rule uses some terms in more than one section of subpart D, it defines those terms multiple times. Final paragraph (b) eliminates this unnecessary repetition, thereby making the final rule easier to understand.

Fifth, and finally, in revising final paragraph (b), OSHA used plain and performance-based language. The Agency believes these types of revisions make the terms and definitions easy for employers and workers to understand, and clarifies several issues raised by stakeholders (discussed below).

The following paragraphs discuss the terms and definitions included in final paragraph (b).

Alternating tread-type stair. The final rule, similar to the proposal, defines this term as a type of stairway that consists of a series of treads usually attached to a center support in an alternating manner, such that a worker typically does not have both feet on the same level while using the stairway. The limited width of the treads makes it difficult or impossible for workers to place both feet on a single tread. OSHA does not consider alternating tread-type stairs to be “standard stairs” as defined in final § 1910.21(b).

The existing rule did not specifically address or define alternating tread-type stairs. The definition in the final rule is consistent with ANSI/ASSE A1264.1–2007. OSHA received no comments on the proposed definition and adopts it as discussed.

Anchorage. This is a new term added to the final rule. An anchorage is defined as a secure point of attachment for equipment such as lifelines, lanyards, deceleration devices and rope descent systems. Anchorages can also be a component of a fall protection system. An anchorage may be installed to serve such purpose or may be a fixed structural member such as a post, beam, girder, column, floor, or wall that is an integral part of a structure. An anchorage must be capable of safely

supporting the impact forces applied by a fall protection system.

OSHA drew the term and definition for “anchorage” from the § 1910.140, Personal fall protection systems. The definition is consistent with the construction fall protection (§ 1926.500(b)), the general industry powered platforms (§§ 1910.66, appendix C, Section I(b)), and the shipyard-employment fall protection standards (§ 1915.151(b)). It also is consistent with the “anchorage” definition in ANSI/ASSE A10.32–2012 (Section 2.4) and ANSI/ASSE Z359.0–2012 (Section 2.5). See § 1910.140 for additional information and discussion of stakeholder comments on the definition of “anchorage.”

Authorized. This final term, like the proposal, refers to a worker who the employer assigns to perform a specific type of duty, or be in a specific location or area in the workplace. The work that authorized employees perform and the work locations where they work often involve situations or conditions where fall hazards are present, such as the working side of teeming or slaughtering platforms, and open/unguarded repair pits.

OSHA notes that once the employer assigns an authorized employee to perform certain work tasks or to be in a certain location, the worker may continue to perform those tasks or be in such work locations without further approval. OSHA did not receive any comments on the proposed definition and adopts it as discussed.

Cage. This term in the final rule, like the proposal, means an enclosure mounted on the side rails of a fixed ladder or fastened to a structure behind the fixed ladder. The final definition also specifies that a cage surrounds the climbing space of the ladder. This will contain the worker and direct a falling worker to a lower landing. A cage may also be called a “cage guard” or “basket guard.”

This definition is essentially the same as the definition for “cage” found in existing § 1910.21(e)(11); it also is consistent with ANSI A14.3–2008, American National Standard for Ladders—Fixed—Safety Requirements. OSHA did not receive any comments on the proposed definition and adopts it with only minor revisions for clarity.

Carrier. Final paragraph (b), similar to the proposed rule, defines a carrier as the track of a ladder safety system that consists of a flexible cable or rigid rail attached to the fixed ladder or immediately adjacent to it. The final definition is consistent with ANSI A14.3–2008 (Section 3). The final rule clarifies that fixed ladders may have

carriers mounted to them, usually onto the ladder face or immediately adjacent to the ladder. OSHA received no comments on the proposed definition and adopts it with the clarifications discussed.

Combination ladder. Final paragraph (b), like the proposed rule, defines a combination ladder as a portable ladder that an employer can use as a stepladder, extension ladder, trestle ladder, or a stairway ladder. The final definition also specifies that employers may use the components of a combination ladder separately as a single ladder.

The final definition is consistent with ANSI A14.1–2007, ANSI A14.2–2007, and ANSI A14.5–2007. OSHA did not receive any comments on the proposed definition and adopts it with only minor revisions for clarity.

Dangerous equipment. The final rule adds this term and defines it as equipment, such as vats, tanks, electrical equipment, machinery, equipment or machinery with protruding parts, or other similar units that, because of their function or form, may harm an employee who falls into or onto it.

This new definition was added in response to a recommendation from Northrop Grumman Shipbuilding that OSHA define “dangerous equipment” in the final rule (Ex. 180). OSHA drew the new definition from the construction fall protection standard (§ 1926.500(b)).

Designated area. This term means a distinct portion of a walking-working surface delineated by a warning line in which work may be performed without additional fall protection. Examples of additional fall protection include guardrails, safety nets, and personal fall protection systems. As mentioned in the proposed rule and in the discussion of final § 1910.28(b)(13), a designated area is a non-conventional fall protection method.

The final rule allows employers to use designated areas for work on low-slope roofs (final § 1910.28(b)(13)). The concept of a designated area in the final rule is similar to controlled access zones and warning line systems in OSHA’s construction fall protection standards (§§ 1926.500(b) and 1916.502(g) and (h)), which also do not require the use of conventional fall protection in specified situations.

The final definition differs from the proposal in that the proposed definition included the term “temporary” work, while the final does not. OSHA continues to believe that employers need to limit use of designated areas to short and brief tasks, such as equipment repair or annual maintenance, that

workers perform on infrequent occasions; *i.e.*, employers are not to use designated areas for lengthy or routine jobs that involve frequent exposure to fall hazards. However, including “temporary” in the definition is unnecessary because final § 1910.28(b)(13)(ii) already limits the use of designated areas to work that is both temporary and infrequent. OSHA did not receive any comments on the proposed definition and adopts it as discussed.

Dockboard. In the final rule, dockboard means a portable or fixed device that spans a gap or compensates for the difference in elevation between a loading platform and a transport vehicle. The definition also specifies that dockboards include, but are not limited to, bridge plates, dock plates, and dock levelers. Examples of transport vehicles include motor vehicles, trucks, trailers, rail cars, and other vehicles.

The final rule uses the term “transport vehicle” in place of the proposed term “carrier.” OSHA believes “transport vehicle” is clear and familiar to employers as it is a commonly used term for a cargo-carrying vehicle. The Agency drew the term from ANSI MH30.2–2005.

The final rule adds examples of devices that OSHA includes within the definition of dockboards, including bridge plates, dock plates, and dock levelers. The Agency believes that providing these examples will help employers and workers better understand whether devices manufactured under other names are “dockboards.” OSHA notes that the list of dockboard examples is not exhaustive. That is, any device that employers use to span a gap or compensate for the difference in levels between a loading platform and transport vehicle is a dockboard for the purposes of final subpart D.

OSHA did not receive any comments on the proposed definition and adopts the definition with the changes discussed above.

Equivalent. In the final rule, this term means alternative designs, equipment, materials, or methods that the employer can demonstrate will provide an equal or greater degree of safety for workers compared to the designs, equipment, materials, or methods specified in this subpart.

OSHA proposed revising the definition of “equivalent” in existing § 1910.23(g)(6) to incorporate language from the construction standards for fall protection, stairways, and ladders standards (§§ 1926.450(b); 1926.500(b); and 1926.1050(b)). These standards specify that the employer has the

burden to demonstrate that the alternate designs, materials, methods, or items will provide an equal or greater degree of safety for workers than the designs, materials, methods, or items the final rule specifies or requires. OSHA did not receive any comments on the proposed definition and finalizes the term so it is consistent with OSHA construction standards.

Extension ladder. Final paragraph (b), like the proposed rule, defines this term as a portable ladder that is non-self-supporting and is adjustable in length. The final rule consolidates into one term, and simplifies the language in, the definitions in existing § 1910.23(c)(4) and (d)(4); this existing provision states that an extension ladder “consists of one or more sections traveling in guides or brackets so arranged as to permit length adjustment.” OSHA believes that the concise, plain language in the final definition will enhance understanding of requirements involving extension ladders; moving the specifications currently in the existing standards to final § 1910.23 also should improve understanding of these requirements.

The final definition generally is consistent with ANSI A14.1–2007, ANSI A14.2–2007, and ANSI A14.5–2007. OSHA did not receive any comments on the proposed definition and adopts it as proposed.

Failure. Final paragraph (b), similar to the proposed rule and construction standards (§§ 1926.450(b); 1926.500(b); and 1926.1050(b)), defines “failure” as a load refusal, breakage, or separation of component parts. The final definition explains that a “load refusal” is the point at which the ultimate strength of a component or object is exceeded. To illustrate, if the load exceeds the ultimate strength of a walking-working surface, such as an elevated work platform, the platform likely will collapse.

For the purpose of this definition, load refusal includes permanent deformation of a component part, which is consistent with ANSI/ASSE A1264.1–2007 (Section 2.3). For example, elongation of a connector that causes the connector to lose its strength is the type of permanent deformation OSHA intends the final definition to cover. Similarly, damage to a guardrail system that weakens the bolts or other fasteners so the system cannot support a worker’s weight is the type of permanent deformation the final definition intends to covers.

OSHA did not receive any comments on the proposed term and definition and adopts the definition with minor editorial changes for clarity.

Fall hazard. This term, in the final rule, means any condition on a walking-working surface that exposes a worker to a risk of harm from a fall on the same level or to a lower level. The final definition is almost identical to the proposal; however, the final rule uses “risk of harm” in place of “injury.” It is clear from the Analysis of Risk (Section II) section and the Final Economic Analysis (FEA) (Section V) that worker exposure to fall hazards can result in death as well as injury. OSHA believes the language in the final definition more accurately and fully captures the range of adverse outcomes that can result from falls.

In response to the proposal, OSHA received one comment from Mr. David Hoberg of DBM Corporations, recommending that OSHA add a specific height to the definition of fall hazard (Ex. 206). He said that a specific height is needed for enforcement purposes. OSHA disagrees. The risk of a fall or other harm exists at any height, including on the same level. That said, OSHA has established specific heights that trigger fall protection requirements in final § 1910.28. The final definition is adopted as proposed.

Fall protection. The final rule, like the proposed rule, defines “fall protection” as any equipment, device, or system that prevents a worker from falling from an elevation or that mitigates the effect of such a fall. For the purposes of the final rule, “mitigates the effect” means that the fall protection prevents the worker from coming into contact with a lower level if a fall occurs. As noted in the preamble to the proposed standard, examples of fall protection include guardrail systems, safety net systems, ladder safety systems, personal fall arrest systems, and similar fall protection systems. OSHA did not receive any comments on the proposed definition and adopts it with minor revisions for clarity.

Fixed ladder. The final definition of fixed ladder, which is generally consistent with existing § 1910.21(e)(2) and the proposed rule, means a ladder with rails or individual rungs that is permanently attached to a structure, building, or equipment. The definition also states that fixed ladders include individual-rung ladders, but do not include ship stairs, step bolts, or manhole steps.

The final definition differs from the existing and proposed rules by clarifying what OSHA does not consider to be fixed ladders. Accordingly, the final definition specifies that fixed ladders do not include ship stairs (ship ladders), step bolts, and manhole steps. Although these devices share some of

the same characteristics of fixed ladders, such as a vertical or steep slope, the final rule clarifies that they are not fixed ladders, and therefore, are covered under separate provisions of the final rule.

While fixed ladders include ladders attached to equipment, OSHA notes ladders that are designed into or are an integral part of machines or equipment are excluded from coverage by final § 1910.23(a)(2).

The final definition, as revised, is consistent with OSHA's stairways and ladders standard for construction (§ 1926.1050(b)) and ANSI A14.3–2008 (Section 3). OSHA received no comments on the proposed definition and finalizes it with the revisions discussed.

Grab bar. This term means an individual horizontal or vertical handhold installed to provide workers with access above the height of a ladder. The final definition revises the existing and proposed rules in two respects. First, the final definition adds language indicating that employers can use grab bars installed either horizontally or vertically. OSHA received one comment about the orientation of grab bars. Nigel Ellis, of Ellis Fall Safety Solutions, recommended OSHA require employers to use only horizontal grab bars when the length of the bars exceeds six inches because it would be impossible to stop workers' hands from sliding down the vertical grab bar during a fall (Ex. 155). He also cited a University of Michigan study that recommended using only horizontally oriented grab bars (Ex. 155, discussing Young J, *et al.* "Hand-Handhold Coupling: Effective Handle Shape, Orientation, and Friction on Breakaway Strength," 51 Human Factors 705–717 (2009)). OSHA is not adopting Mr. Ellis' recommendations because the customary industry practice, as specified by the ANSI fixed ladder standard (ANSI A–14.3–2008 (Section 5.3.3.1)), is to allow the use of either horizontal or vertical grab bars and not to limit the length of vertical grab bars.

Second, the final definition deletes language in existing § 1910.21(e)(14) and the proposed rule specifying that employers use only grab bars placed adjacent to a ladder or used as an extension of a ladder. The final definition revises this language to ensure that employers use only grab bars installed above the height of the ladder, not adjacent to it. When grab bars are also in a vertical orientation relative to a ladder, they are not an extension of the ladder; therefore, the final definition removed the language from the proposal referring to grab bars as an extension of a ladder.

Guardrail system. In the final rule, similar to the proposal, this term means a barrier erected along an unprotected or exposed side, edge, or other area of a walking-working surface to prevent workers from falling to a lower level. A guardrail system generally consists of vertical, horizontal, or inclined supports; top rails; midrails; screens; mesh or solid panels; intermediate vertical members; or other equivalent structural members. Guardrail systems can be either permanent or removable. The final definition generally is consistent with the scaffold and fall protection standards for construction (§§ 1926.450(b) and 1926.500(b)).

The proposed and final definition simplify the existing definitions in § 1910.21(a)(6) and (g)(7) by consolidating the terms "guardrail" and "standard railing" into the single term "guardrail system." The existing definitions are similar to, and included within, the final definition. As a result, there is no need to include both terms and definitions in the final rule since the single term "guardrail system" adequately covers both terms.

The final rule clarifies the proposed definition by specifying that guardrails are barriers that employers may erect on a side, edge, or other area of a walking-working surface (e.g., hole). The barrier may be a framework or system of individual units used together to provide protection. For example, a guardrail system may consist of several barriers surrounding a hole.

OSHA did not receive any comments on the proposed definition and, therefore, adopts it as explained.

Handrail. The final rule, like the proposed rule and the construction stairways standard (§ 1926.1050(b)), defines a handrail as a rail used to provide workers with a handhold for support. Handrails may be horizontal, vertical, or sloping. According to ANSI/ASSE A1264.1–2007 (Sections 2.6 and 2.7), handrails also may be part of a stair rail or stair rail system (i.e., the top rail).

The proposed and final definition simplify and consolidate into one term the three definitions for "handrail" in the existing rule in §§ 1910.21(a)(3), (b)(1), and (g)(8). Specifically, the final definition deletes existing specifications for the materials (e.g., pipe, bar) that employers must use for handrails, which makes the final definition consistent with final § 1910.29, Fall protection systems criteria and practices. The final definition also is consistent with ANSI/ASSE A1264.1–2007 (Section 2.7). OSHA did not receive any comments on the proposed definition and adopts the final definition as proposed.

Hoist area. In the final rule, like the proposal, a hoist area is defined as any elevated access opening to a walking-working surface through which equipment or materials are loaded or received. The final definition deletes the term "hoisted" before the phrase "equipment or material" in the proposed definition because the definition covers any means of loading, passing, or receiving equipment or materials through the hoist area. OSHA did not receive any comments on the proposed definition and finalizes it with the revisions discussed.

Hole. The final rule, similar to the proposed rule, defines a hole as a gap or open space in a floor, roof, horizontal walking-working surface, or similar surfaces that is at least two inches in its least dimension. Similar surfaces include runways, dockboards, stair treads, and other low-slope or inclined surfaces where employees walk or work. The existing rule contains four different terms for holes and openings in walking-working surfaces: Floor hole (existing § 1910.21(a)(1)), floor opening (existing § 1910.21(a)(2)), wall hole (existing § 1910.21(a)(10)), and wall opening (existing § 1910.21(a)(11)). Each of the terms has a separate definition. ANSI/ASSE A1264.1–2007 contains the same four terms and definitions.

The final definition consolidates and simplifies the existing rule in two respects. First, the final rule designates a "hole" as a gap or open space in "horizontal walking-working surfaces," (e.g., floor, roof, similar surfaces) and an "opening" as a gap or space in "vertical walking-working surfaces" (e.g., wall or partition). The final definition of "hole" revises the proposed definition by adding "horizontal" and "similar surfaces" so employers know holes are not limited to floors or roofs.

Designating the term "hole" to refer to gaps in horizontal or similar walking-working surfaces allows OSHA to simplify and consolidate the existing definitions for "floor hole" and "floor opening" into a single term: "hole." The existing rule in § 1910.21(a)(1) defines a "floor hole" as a gap that is more than one inch but less than 12 inches at its least dimension, while existing § 1910.21(a)(2) defines a "floor opening" as a gap that is 12 inches or more at its least dimension. Combining the two terms also makes the final definition consistent with the definition in the construction fall protection standard in § 1926.500(b). The final rule, like the proposal, also expands the term "hole" to cover gaps in roofs and similar horizontal walking-working surfaces, as well as floors.

Second, consistent with the Plain Writing Act of 2010, the final definition substitutes “open space” for “void” to make the term easier to understand.

OSHA received one comment on the proposed rule. Mark Damon, of Damon, Inc., questioned the need for a definition of hole in a fall protection standard, asserting that workers could not fall through a two-inch or larger gap (Ex. 251). OSHA disagrees with Mr. Damon’s assertion. Although a worker cannot fall through a narrow (2-inch) hole in a walking-working surface, such holes can cause workers to trip and fall on the same level or to a lower level. Such falls can result in worker injury or death. As such, OSHA is retaining the definition with the changes discussed above.

Individual-rung ladder. This is a type of fixed ladder that has rungs individually attached to a building or structure. It does not include manhole steps. The proposed rule also excluded manhole steps.

Although manhole steps have individual rungs, they involve unique conditions, and OSHA addresses these conditions in a separate section of final subpart D (§ 1910.24). Therefore, the final definition excludes manhole steps from the individual-rung ladder definition to prevent any confusion and emphasize that final § 1910.24, not final § 1910.23 applies to manhole steps.

The proposed rule also included ladders consisting of rungs individually attached to a piece of equipment. Because final rule § 1910.23(a)(2) excludes ladders designed into or integral to a piece of equipment, there was no need to include such ladders within the definition of individual rung ladders.

OSHA did not receive any comments on the proposed definition and adopts it with the revisions discussed above.

Ladder. This term means a device with rungs, steps, or cleats used to gain access to a different elevation. The final rule simplifies and consolidates into one definition the three definitions of “ladder” in the existing rule in § 1910.21(c)(1), (d)(1), and (e)(1). The final definition also eliminates references to ladder specifications (e.g., “joined at regular intervals”) since they simply repeat requirements addressed by final § 1910.23.

OSHA received one comment on the proposed “ladder” definition. Steve Smith, of Verallia, recommended that OSHA clarify the term because he said that the phrase “a device with steps” is ambiguous and could include stairs as well as a ladder (Ex. 171). OSHA does not agree that stakeholders might mistakenly think the term “ladder”

includes stairs. The proposed and final definitions of “ladder” are essentially the same as the one that all of the ANSI A14 ladder standards use: “Ladder. A device incorporating or employing steps, rungs, or cleats on which a person may step to ascend or descend” (see, e.g., ANSI A14.1–2007 (Section 4); ANSI A14.2–2007 (Section 4); ANSI A14.3–2008 (Section 3); ANSI A14.5–2007 (Section 4)). The ANSI A14 ladder standards have been in place for years, and OSHA believes employers, workers, and manufacturers clearly understand the term “ladder,” as defined in the ANSI standards, and will not confuse the term with stairs. However, to ensure the final rule is understandable, the final rule clarifies the definitions of “rung, step, or cleat” and “tread” to specify that a “step” is a cross-piece of a ladder and “tread” refers to the horizontal part of “stairways (stair).”

Ladder safety system. In the final rule, a ladder safety system is a system designed to eliminate or reduce the possibility of falling from a ladder. The final definition explains that a ladder safety system usually consists of a carrier; a safety sleeve, which is a moving component that travels on the carrier; a lanyard; connectors; and a body harness. The final definition also specifies that cages and wells are not ladder safety systems.

The existing rule in § 1910.21(e)(13) uses a similar term, “ladder safety device,” which also excludes ladder cages and wells. OSHA’s construction ladder standard in § 1926.1053 uses the same term, but does not include a definition of the term. The final definition is consistent with the ANSI fixed-ladder standard (ANSI A14.3–2008; Section 3).

OSHA received one comment on the definition of ladder safety system. Darryl Hill, of the American Society of Safety Engineers (ASSE), urged OSHA to prohibit the use of body belts in ladder safety systems as the Agency did with personal fall arrest systems:

ASSE opposes the use of body belts. There are good “safety reasons” . . . for supporting OSHA’s decision in 1998 to ban the use of body belts as part of a personal fall arrest system. OSHA needs to take this opportunity to ban their use entirely for the same reasons it banned them in 1998. A full body harness distributes arresting forces over larger areas of the workers body and provides better suspension support, as research has repeatedly confirmed (Ex. 127).

OSHA agrees with ASSE that full-body harnesses provide better suspension support precisely because they distribute arresting/impact forces over a larger area of a worker’s body than body belts. To that end, the final

rule in § 1910.140(d)(3) retains OSHA’s 1998 prohibition on the use of body belts as part of a personal fall arrest system. OSHA believes this requirement in final § 1910.140 addresses ASSE’s concern and the Agency encourages employers to provide, and require that their workers use body harnesses when using any type of personal fall protection equipment.

Low-slope roof. This is a new term that OSHA added to the final rule. Low-slope roof is defined as a roof with a slope less than or equal to a ratio of 4 in 12. A ratio of 4 in 12 means a vertical rise of 4 units (e.g., inches, feet, meters) to every 12 units of horizontal run. The final definition is almost identical to the definition of “low-slope roof” found in the construction fall protection standard in § 1926.500(b).

OSHA added this term to final paragraph (b) because the final rule includes a new provision on controlling fall hazards on low-slope roofs (final § 1910.28(b)(13)), which is consistent with the construction fall protection standard in § 1926.501(b)(10). OSHA is aware that low-slope roofs also are referred to as “flat roofs.” However, even a so-called “flat roof” has some slope to allow for drainage. As such, OSHA believes that the term “low-slope roof” more accurately represents these roofing configurations.

Lower level. The final rule, similar to the proposal, defines this term as a surface or area to which workers could fall. The final definition lists examples of lower levels including, but not limited to, ground levels, floors, roofs, ramps, runways, excavations, pits, tanks, materials, water, equipment, and similar surfaces and structures, or portions thereof. The final rule adds to the proposed definition of lower level “surface” and “structures, or portions thereof,” which make the final definition consistent with the definition of “lower level” in the construction fall protection standard in § 1926.500(b). The construction standards for scaffolds, and stairways and ladders, also have similar definitions (§§ 1926.450(b); 1926.1050(b)). OSHA did not receive any comments on the proposed definition and adopts it with the changes discussed above.

Manhole steps. The final rule, similar to the proposal, defines these as steps that are individually attached to, or set into the walls of a manhole structure. Although the steps are individually set into or attached to the walls, manhole steps are not considered “individual-rung ladders” as stated in the final definition of “fixed ladders.” Manhole steps also do not include manhole entry

ladders which are portable and are covered in final § 1910.23, Ladders.

OSHA did not receive any comments on the proposed definition and adopts it with minor editorial changes.

Maximum intended load. The final rule, similar to the proposal, defines this term as the total load (weight and force) of all employees, equipment, vehicles, tools, materials, and other loads the employer reasonably anticipates to be applied to a walking-working surface at any one time. The existing rule in § 1910.21(f)(19) and the construction standards for scaffolds, and stairways and ladders in §§ 1926.450(b) and 1926.1050(b) have similar definitions.

OSHA clarified the final definition in several ways. First, the proposed rule indicated that “maximum intended load” was also known as “designed working load.” OSHA is aware that “designed working load” is an outdated term; thus, the final definition deletes it. Second, the final definition adds language clarifying that the maximum intended load includes the combined total weight of the load, as well as the force of the load.

Third, the final definition adds “vehicles” to the list of potential components of a total load. Vehicles are found on many types of walking-working surfaces, and determinations of the maximum intended load must include the weight of vehicles, and the load being carried by the vehicles, applied to the walking-working surface.

Fourth, the final definition adds language clarifying that employers are responsible for determining the maximum load in terms of all equipment, vehicles, materials, workers, and other items they reasonably anticipate applying to a walking-working surface. Requiring that an employer know the maximum weight and force a walking-working surface can support and the total weight and force of the loads they reasonably anticipate applying to that surface is essential in safeguarding workers from harm, e.g., falls from elevated surfaces and being struck by falling objects. OSHA believes the language added to the final definition clarifies the employers’ responsibility.

Fifth and finally, the final definition adds the language “at any time” to make the definition consistent with other OSHA standards (e.g., existing §§ 1910.21(f)(19); 1926.450(b); 1926.1050(b)).

OSHA did not receive any comments on the proposed definition and adopts it with the revisions discussed above.

Mobile. The final rule, like the proposed rule, defines “mobile” as being manually propelled or movable.

The existing rule defines “mobile” as manually propelled (existing § 1910.21(g)(12)). The proposed and final definitions update the existing rule to make it consistent with ANSI A14.7–2011 (Section 3), which specifies that “mobile” also means “moveable.” OSHA believes that the final definition also clarifies the definitions of “mobile ladder stand” and “mobile ladder stand platform.”

In the proposal, OSHA asked for comment on whether it is necessary to define a common term like “mobile,” but the Agency did not receive any comments. Therefore, OSHA adopts the proposed definition with one editorial clarification (replacing “and/or” with “or”).

Mobile ladder stand. This term (also known as “ladder stand”) means a mobile, fixed-height, self-supporting ladder usually consisting of wheels or casters on a rigid base and steps that leads to a top step. The final definition explains that a mobile ladder stand also may have handrails and is designed for use by one worker at a time. A parenthetical in the definition refers to “ladder stand” as another name for mobile ladder stands; “ladder stand” is the term used for mobile ladder stands in existing §§ 1910.21(g)(9), 1926.450(b), and 1926.1050(b), and ANSI A14.7–2011 (Section 3).

The final definition clarifies the proposed rule and OSHA’s existing definition for ladder stand in several ways. First, the final definition adds language clarifying that mobile ladder stands usually consist of wheels or casters on a rigid base, in addition to steps. This addition clearly distinguishes ladder stands from other types of ladders. Second, the final rule simplifies and clarifies the definition by using the term “steps” in place of “treads in the form of steps,” which is in the existing and proposed definitions. The term “step,” which final paragraph (b) also defines, is clear and well understood, and does not require further elaboration.

Third, the final definition deletes the proposed term “flat” used to describe ladder stand steps because it is not necessary. Final § 1910.23 establishes requirements for ladder stand steps (final §§ 1910.23(b)(1) and (b)(4)). OSHA did not receive any comments on the proposed definition and adopts it with the clarifications discussed above.

Mobile ladder stand platform. The final rule defines this term as a mobile, fixed-height, self-supporting unit having one or more standing platforms that are provided with means of access or egress. Existing OSHA standards do not include or define the term “mobile ladder stand

platforms.”¹¹ Frequently employers use mobile ladder stand platforms to provide elevated standing or working surfaces for one or more employees.

The final definition is consistent with ANSI A14.7–2011, although the ANSI standard, like the proposed rule, includes the definition of mobile ladder stand. OSHA did not receive any comments on the proposed definition and finalizes the definition with minor clarifications.

Open riser. The final rule, which is similar to existing § 1910.21(b)(3) and the proposed rule, defines “open riser” as a gap or space between treads of stairways that do not have upright (vertical) or inclined members (risers).

OSHA clarified the proposed definition slightly by adding terminology to the final definition that it used in the final definition of “riser.” This terminology specifies that, in addition to not having upright (vertical) members, stairways with open risers do not have inclined members. This revision makes the final definition consistent with ANSI/ASSE A1264.1–2007 (Section 2.11).

OSHA did not receive any comments on the proposed definition and adopts it with the clarifications discussed above.

Opening. The final rule, similar to the proposed rule, defines this term as a gap or open space in a wall, partition, vertical walking-working surface, or similar surface that is at least 30 inches high and at least 18 inches wide, through which a worker can fall to a lower level.

As discussed in the definition of “hole,” the final rule simplifies and consolidates four terms in the existing rule that distinguish between openings and holes in walking-working surfaces. As mentioned, the term “opening” in the final rule refers to gaps or open spaces in areas that are generally vertical, such as walls and partitions. The final definition consolidates into one term the definitions of “wall hole” and “wall opening” in existing § 1910.21(a)(10) and (a)(11). This consolidation makes the final definition of “opening” consistent with the construction fall protection standard

¹¹ OSHA notes that the existing general industry rule includes the terms “platform ladder” and “mobile work platform.” Existing § 1910.21(d)(5) defines “platform ladder” as a “self-supporting ladder of fixed steps with a platform provided at the working level.” Existing § 1910.21(g)(13) defines “mobile work platform” as “a fixed work level one frame high on casters or wheels, with bracing diagonally from platform to vertical frame.” Both terms include elements of the final definition of “mobile ladder stand platform.” In the proposed rule, OSHA consolidated and simplified existing terms into one term: Mobile ladder stand platform.

(§ 1926.500(b)), one of OSHA's stated goals of the final rule. OSHA believes that having consistent general industry and construction definitions will facilitate compliance with the final rule. The final definition also is nearly identical to the definition of "opening" in ANSI/ASSE A10.18–2012 (Section 2.9).

Consistent with the Plain Writing Act of 2010, the final definition substitutes "open space" for "void" to make the term easier to understand.

OSHA did not receive any comments on the proposed definition and adopts the term as discussed above.

Personal fall arrest system. This is a new term OSHA added to subpart D in the final rule and means a system used to arrest a worker's fall from a walking-working surface if one occurs. The final definition explains that a personal fall arrest system consists of a body harness,¹² anchorage, connector, and a means of connecting the body harness and anchorage, such as a lanyard, deceleration device, lifeline, or a suitable combination of these. A definition for personal fall arrest systems was provided in proposed subpart I in § 1910.140 (75 FR 29147). Because the term is used in final subpart D, and OSHA believes the term is integral to understanding the final rule, the Agency decided to include the same definition in subpart D.

The final definition is consistent with OSHA's construction standards for scaffolds and fall protection in §§ 1926.450(b) and 1926.500(b), respectively, and ANSI/ASSE Z359.0–2012 (Section 2.98). See the preamble to final § 1910.140 for further discussion and comments on personal fall arrest systems.

Personal fall protection system. This is a new term OSHA added to subpart D in the final rule and means a system (including all components) an employer uses to provide protection from falling or to safely arrest a worker's fall if one occurs. The final definition identifies examples of personal fall protection systems, including personal fall arrest systems, travel restraint systems, and positioning systems.

Personal fall protection systems have the following components in common: An anchorage, body support (*i.e.*, body harness or body belt), and connectors (*i.e.*, means of connecting the anchorage and body support).

A definition for personal fall protection systems was provided in the proposed rule, in proposed § 1910.140

(75 FR 29147). Because the term is used in final subpart D, and OSHA believes the term is integral to understanding the final rule, the Agency decided to include the same definition in subpart D. The requirements for, and comments on, personal fall protection systems are in final § 1910.140, Personal fall protection systems.

Platform. In the final rule, like the proposal, a platform is defined as a walking-working surface that is elevated above the surrounding area. OSHA drew the proposed and final definitions from existing § 1910.21(a)(4) and the construction scaffold standard in § 1926.450(b). The final rule is consistent with the definition in ANSI/ASSE A1264.1–2007.1–2007 (Section 2.14).

OSHA did not receive any comments on the proposed definition and adopts it as proposed with a minor editorial revision.

Portable ladder. The final rule, like the proposal, defines this term as a ladder that can readily be moved or carried, and usually consists of side rails joined at intervals by steps, rungs, or cleats. The definition in the final rule is consistent with the definition of portable ladder in ANSI A14.1–2007 (Section 4), ANSI A14.2–2007 (Section 4), and ANSI A14.5–2007 (Section 4).

The final rule clarifies the definition by deleting the language "rear braces" from the proposed definition to eliminate any confusion about what constitutes a portable ladder for the purposes of the final rule. Rear braces are a structural component of self-supporting portable ladders; however, as mentioned above, the final definition of portable ladder is not limited to those types of ladders.

OSHA notes that portable ladders include, but are not limited to, self-supporting, non-self-supporting, articulated, sectional, extension, special purpose, and orchard ladders. OSHA believes that the term portable ladders should be widely understood by employers.

OSHA received one comment on the proposed definition. Virginia Ruiz, representing California Rural Legal Assistance Foundation and Farmworker Justice, urged OSHA to cover agriculture operations in the final rule (Ex. 201). In her comment, Ms. Ruiz pointed out that proposed revisions to the California general industry portable-ladder standards (Title 8 CCR, Sections 3276, 3277, 3278, 3287, and 3413) cover special-purpose orchard and fruitpickers' ladders (Ex. 201). For further discussion on the inclusion of agriculture operations in subpart D, see

the discussion above in final paragraph (a), Scope.

Positioning system (work-positioning system). This is a new definition OSHA added to subpart D in the final rule. It means a system of equipment and connectors that, when used with a body harness or body belt, allows an employee to be supported on an elevated vertical surface, such as a wall or window sill, and work with both hands free. Positioning systems also are called "positioning system devices" and "work-positioning equipment."

The definition is the same as the definition in § 1910.140(b). The newly revised electric power generation, transmission, and distribution standard in § 1910.269, and the construction standard for fall protection in § 1926.500(b), also contain similar terms and definitions. The final definition also is consistent with ANSI/ASSE Z359.0–2012 (Section 2.120).

Although the proposed rule for subpart D used the term work-positioning system, the proposal did not define it. The Agency believes it is important to define positioning systems in final subpart D to ensure that employers and workers understand the meaning of this term as used in this subpart, most importantly that such systems do not arrest falls from elevated walking-working surfaces.

Qualified. In the final rule, like in the proposal, "qualified" describes a person who, by possession of a recognized degree, certificate, or professional standing, or who by extensive knowledge, training, and experience has successfully demonstrated the ability to solve or resolve problems relating to the subject matter, the work, or the project. This definition is the same as the definition in the proposed rule and final § 1910.140(b), as well as several construction standards (§§ 1926.32(m); 1926.450(b)) and ANSI A10.32–2012 (Section 2.41).

The final definition, however, differs from the definition of "qualified person" in the general industry powered platforms standard (§ 1910.66, Appendix C, Section I(b)) and ANSI/ASSE Z359.0–2012. The § 1910.66 definition, for instance, requires that qualified persons have a degree or professional certificate, not only professional standing, plus extensive knowledge, training, and experience. OSHA explained in the proposed rule that to require qualified persons to meet the definition in the powered platforms standard would mean that the qualified person "would most likely need to be an engineer" (75 FR 28905).

Two stakeholders recommended that the Agency adopt the definition in

¹² OSHA notes the final rule prohibits the use a body belt as part of a personal fall arrest system (final § 1910.140(d)(3)).

§ 1910.66 (Exs. 155; 206). Mr. Ellis urged OSHA to adopt the § 1910.66 definition at least as it pertains to certification of anchorages. He also said:

After investing 40 years in industrial fall protection it is important to feed back my experiences from hundreds of site visits and contacts over that time. I am strongly recommending that the word “or” be replaced with “and”. Both are critically important and the anchorage must be documented with at least a sketch or engineering drawing which presently it rarely is except for 1910.66 App. C. In America, anchorages are mostly guesswork and this does not do justice to “the personal fall arrest system” term that OSHA is seeking to establish unless the engineering background is added. Furthermore the design of anchorages can easily be incorporated into architects and engineers drawings but is presently not because there is no requirement for an engineer. This simple change may result in saving over one half the lives lost from falls in the USA in my opinion (Ex. 155).

Mr. Hoberg, of DBM, Inc., said that defining qualified “has been a struggle for decades” and that the § 1910.66 definition “is a good one”:

Two things have become commonly accepted—a competent person is one who has enough experience and knowledge to know when to call a qualified person. A qualified person is one who knows the technical and working practice aspects of the problem.

The problem we have had was how to limit the ‘I know, therefore I am a qualified person’ (Ex. 206).

The final rule does not adopt the definition of “qualified person” in § 1910.66 appendix C. The definition of “qualified” in the final rule has been in use for years in the referenced construction standards. OSHA believes the definition is clear and employers understand it. In addition, OSHA believes that employers understand and can distinguish between qualified and competent persons.

With regard to the certification of anchorages, OSHA believes that the anchorage requirements in final §§ 1910.27 and 1910.140, combined with the final definition of “qualified” person, are adequate to ensure worker safety. OSHA notes that building owners are free to have their building anchorages certified by professional engineers. Therefore, OSHA finalizes the definition of “qualified” as proposed.

Ramp. The final rule defines ramp as an inclined walking-working surface that is used to gain access to another level. Employers use ramps to move workers, equipment, materials, supplies, and vehicles from one level to another. Ramps also allow workers to access

another level when stairs are not available or workers cannot use them (such as for workers who use wheelchairs). Ramps generally are permanent devices or structures, although some ramps may be portable, such as ramps that employers use temporarily for accessing a different level where moving equipment or materials up or down stair risers or curbs is impractical.

The proposed rule, similar to the 1990 proposal, defines ramp as an inclined surface between different elevations that is used for the passage of employees, vehicles, or both. The final rule revises the proposed definition for two reasons. First, the proposed definition only refers to the passage of employees and vehicles, but not other things that may be moved across ramps, such as materials, supplies, and equipment. The final definition does not limit the use of ramps as passageways. Second, the final rule simplifies the proposed definition to make it consistent with the definition in ANSI/ASSE A1264.1–2007 (Section 2.16).

OSHA did not receive any comments on the proposed definition and adopts it as discussed above.

Riser. In the final rule, this term means an upright (vertical) or inclined member of a stair located at the back of a stair tread or platform that connects close to the front edge of the next higher tread, platform, or landing. The final definition is consistent with ANSI/ASSE A1264.1–2007 (Section 2.17).

The final rule differs from the proposed definition in that the final definition clarifies that risers may also be inclined (nearly vertical), as well as vertical, members of a stair, and connect treads to the next higher tread, platform or landing. The height of a riser is measured as the vertical distance from the tread (horizontal surface) of one step to the top of the leading edge of the tread above it (see Figure D–8.). OSHA did not receive any comments on the proposed definition and adopts it with the clarification discussed above.

Rope descent system. In the final rule, a rope descent system (RDS) is defined as a suspension system that allows a worker to descend in a controlled manner and, as needed, to stop at any time during the descent. The final definition adds language to the proposed definition explaining that the RDS usually consists of a roof anchorage, support rope, a descent device, carabiner(s) or shackle(s), and a chair (seatboard). The final definition also states that an RDS may also be called controlled descent equipment or apparatus; and does not include industrial rope access systems. OSHA

based the final definition of “rope descent system” on the definition of the term in ANSI/IWCA I–14.1–2001, since the existing rule does not include the term.

OSHA revised the final definition in several ways. First, the ANSI/ASSE Z359.0–2012 (Sections 2.13 and 2.100) defines both “automatic descent control device” and “manual descent control device.” However, neither definition encompasses the entire system. The Agency’s final definition, like ANSI/IWCA I–14.1–2001, covers the entire system, not just the descent control device. In light of the ANSI/ASSE Z359.0–2012 definitions, OSHA believes that stating, as in the proposal, that another name for an RDS is “controlled descent device” may be confusing. Therefore, OSHA removed that statement in the final definition. To further clarify the final definition and distinguish it from the terms in ANSI/ASSE Z359.0–2012, OSHA added language identifying components of a typical RDS.

Second, OSHA added language to the final rule specifically excluding industrial rope-access systems from the final definition of “rope descent system.” OSHA received several comments recommending that the term “rope descent system” include industrial rope access systems, either as part of rope descent systems or as a new section (e.g., Exs. 129; 205; 355–7; 347). One commenter said that rope descent systems are a type of industrial rope access system (Ex. 362). However, some commenters believe the definition of “rope descent system” already includes industrial rope access systems (Exs. 69; 72; 122; 168; 178). For example, the American Wind Energy Association (AWEA) said they use industrial rope access systems as rope descent systems for repair and maintenance of wind turbines (Ex. 178). AWEA recommended that the definition of, and requirements for, rope descent systems should incorporate and reference the Society of Professional Rope Access Technicians (SPRAT) and the International Rope Access Technicians Association standards, which AWEA said “are much more developed” than the ANSI/IWCA I–14.1–2001 standard.

In light of the comments, not only does the final definition clarify that rope descent systems do not include industrial rope access systems, but also final § 1910.27, Scaffolds and rope descent systems, explains that the final rule does not cover industrial rope access systems. OSHA agrees, as SPRAT pointed out, that while industrial rope access systems may use equipment similar to rope descent systems (e.g.,

anchorage, body harnesses, lifelines), they are “different in key ways” from rope descent systems (Ex. 355–7). For example, industrial rope access systems are suspension systems that allow the worker to go up or down, while rope descent systems only go down. Also, industrial rope access systems have sit harnesses instead of seatboards or chairs.

Third, OSHA received several comments that opposed OSHA’s characterization of a rope descent system in the proposal as a “variation of the single-point adjustable suspension scaffold” (Exs. 62; 168; 205). For example, Brian Gartner, of Weatherguard Service, Inc., said, “A rope descent system is not a variation of the single point adjustable scaffold. The scaffold has the capability of being raised as well as being lowered, rope descent systems only travel downward, and a scaffold has an area, a platform, to store tools and supplies, stand, etc.” (Ex. 168). OSHA agrees with the commenters and deleted that comparison from the final definition.

Rung, step, or cleat. Similar to the proposal, the final rule defines “rung, step, or cleat” as the cross-piece of a ladder on which a worker steps to climb up and down the ladder. OSHA notes that in the final definition, “steps” only refer to the cross-pieces of ladders. The final definition is consistent with ANSI A14.1–2007 (Section 4), ANSI A14.2–2007 (Section 4), and ANSI A14.5–2007 (Section 4).

The final definition consolidates and simplifies the existing definitions into one term that identifies their common characteristics and purpose (see existing § 1910.21(e)(8), (9), and (10)). The final definition also incorporates plain language (“climb up and down”) to explain that workers use rungs, steps, or cleats to ascend or descend ladders.

OSHA received one comment on the proposed definition. Nigel Ellis said OSHA should retain the separate definitions in the existing rule “to explain a rung is designed for holding and stepping but that a step cannot be held since it is only for the feet (shoes)” (Ex. 155). OSHA does not agree that including such language is necessary.

First, the final definition is consistent with ANSI portable ladder standards (ANSI A14.1–2007, ANSI A14.2–2007, and ANSI A14.5–2007). Rungs, steps, and cleats are all horizontal surfaces for climbing ladders, even if their specifications vary. (Rungs are circular or oval, cleats are rectangular, and steps are flat). Instead of focusing on the differences in the specification, the final rule and the ANSI standards identify, and focus on, the primary purpose of

rungs, steps, and cleats; to provide a place to step to climb up and down the ladder.

Second, OSHA believes it is not accurate to say that “a step cannot be held” (Ex. 155). Although side rails provide handholds for climbing ladders, especially those with steps, neither the final rule nor the ANSI standards prohibit workers for holding onto steps, either while climbing or standing on a ladder. As such, OSHA believes the language Mr. Ellis suggests may cause confusion; therefore, OSHA is not adopting it.

Runway. In the final rule, similar to the proposal, this term means an elevated walking-working surface, such as a catwalk, a foot walk along shafting, or an elevated walkway between buildings. The final definition is consistent with ANSI/ASSE A1264.1–2007 (Section 2.19).

OSHA added three clarifications to the final “runway” definition. First, the final definition substitutes “walking-working surface” for “passageway.” This change makes the definition consistent with the definitions of other terms in final subpart D. Second, the final definition also more clearly indicates that employees use runways to perform work as well as to gain access to other areas in the workplace. Third, the final rule simplifies the definition by substituting plain language (*i.e.*, “elevated”) in place of “elevated above the surrounding floor or ground level” used in the proposed definition.

OSHA did not receive any comments on the proposed definition and adopts it with the clarifications discussed above.

Scaffold. In the final rule, like the proposal and consistent with the construction scaffold standard (§ 1926.450(b)), this term means any temporary elevated or suspended platform and its supporting structure, including anchorage points, used to support workers, equipment, materials, and other items. The final rule also states that, for purposes of final subpart D, “scaffold” does not include crane-suspended or derrick-suspended personnel platforms or rope descent systems.

The final rule consolidates into a single term the two definitions in the existing rule in § 1910.21(f)(27) and (g)(15). The final definition also adds two clarifications to the proposed definition. First, it adds “equipment” to the list of items a scaffold must be capable of supporting. Second, it also clarifies that the final definition of scaffold, including suspension scaffolds, does not include rope descent systems. As discussed above, a number of

commenters opposed characterizing rope descent systems as a type of single-point adjustable scaffold (Ex. 62; 168; 205). One commenter, David Hoberg, with DBM Consultants, said rope descent systems differ in many ways from scaffolds. For instance, he said the stabilization required for rope descent systems over a height of 130 feet differs from the stabilization required for scaffolds (Ex. 206). Consequently, OSHA added to the definition of scaffold that the term does not apply to rope descent systems.

Ship stair (ship ladder). In the final rule, like the proposal, a ship stair, also known as a ship ladder, is a stairway that is equipped with treads, stair rails, and open risers, and has a slope that is between 50 and 70 degrees from the horizontal. The final definition is consistent with ANSI/ASSE A1264.1–2007 (Section 2.22).

Ship stairs are not standard stairs within the meaning of this section. Generally, ship stairs are a type of stairway found in buildings and structures that have limited space, and are used for accessing special use areas, such as but not limited to, attics, roofs, mechanical equipment spaces, etc.

OSHA notes that ship stair is a term of art and use of the term in this subpart is not intended to infer applicability to the shipyard employment, marine terminal, or longshoring industries.

OSHA did not receive any comments on this definition and adopts it with minor editorial revisions for clarity.

Side-step ladder. This term means a type of fixed ladder that requires a worker to step sideways from it to reach a walking-working surface, such as a landing. The final definition is consistent with ANSI A14.3–2008 (Section 3). In the final rule, OSHA revised the proposed definition to emphasize that side-step ladders are a type of fixed ladder (see final § 1910.23(d)(4), (d)(6), and (d)(12)(ii)). The final rule also clarifies that when a worker steps off a side-step ladder onto a walking-working surface, it may be a landing or another type of surface (*e.g.*, roof). The proposed definition, on the other hand, only mentions stepping onto a landing.

OSHA did not receive any comments on the proposed definition and finalizes with the clarifications discussed above.

Spiral stairs. The final rule, similar to the proposal, defines this term as a series of treads attached to a vertical pole in a winding fashion that is usually within a cylindrical space. For clarity, the Agency substituted the language “stairway having a helical (spiral) structure attached to a supporting pole” in the proposal with “treads attached to

a vertical pole in a winding fashion within a cylindrical space.” OSHA drew the definition from the construction standards for stairways and ladders (see § 1926.1050(b)); it also is consistent with the definition of the term in ANSI/ASSE A1264.1–2007 (Section 2.23).

Additionally, in the final rule, OSHA replaced the proposed term “steps” with “treads.” As noted above in the definition for rungs, steps or cleats, in the final rule, OSHA clarifies that steps are a component of ladders whereas treads are components of stairs.

Spiral stairs are not standard stairs within the meaning of this section, and the final rule limits their use in general industry workplaces (see final § 1910.25(b)(8)). Employers generally use spiral stairs generally in workplaces that have limited space.

OSHA did not receive any comments on the proposed definition and adopts it as discussed above.

Stair rail or stair rail system. This term means a barrier erected along the exposed or open side of stairways to prevent workers from falling to a lower level. Stair rail and stair rail systems include, but are not limited to, vertical, horizontal, or inclined rails; grillwork or panels, and mesh. In addition, the top rail of a stair rail system may serve as a handrail. The final definition is consistent with the construction standards for stairways and ladders (see § 1926.1050(b)). The ANSI/ASSE A1264.1–2007 (Section 2.6) standard includes a definition covering “guardrail/railing system/stair railing system” that is applicable to stairways, ramps, landings, portable ladders, hatchway, manholes, and floor openings; the final definition is generally consistent with this ANSI/ASSE standard.

The final definition eliminates “vertical” from the term barriers in order to make the definition consistent with final § 1910.29(f). That provision does not require barriers to be vertical; for example, barriers may be horizontal rails.

OSHA did not receive any comments on the proposed definitions and adopts it with the revision discussed.

Stairway (stairs). The final rule defines stairway (stairs) as risers and treads that connect one level with another. Stairways also include any landings and platforms between those levels. In addition, the final rule specifies that stairway includes standard, spiral, ship, and alternating tread-type stairs.

The existing rule defines stairways as a series of steps leading from one level or floor to another, or leading to platforms, pits, boiler rooms, crossovers,

or around machinery tanks and other equipment that are used more or less continuously or routinely by employees, or only occasionally by specific individuals. A series of steps and landings having three or more risers constitutes stairs or stairway (existing § 1910.21(b)(8)). OSHA did not propose a definition of stairway; however, the Agency decided to retain and revise the existing definition.

The final definition revises the existing definition in several ways. First, the final rule simplifies the definition considerably. OSHA believes the term “stairway” (“stairs”) is commonly understood and does not require a long explanation. Therefore, OSHA limits the final definition to identifying the specific aspects of the stairways the final rule covers.

Second, the final rule removes language in the existing definition that limits stairways to stairs that have “three or more risers” (existing § 1910.28(b)(8)). The proposed rule did not retain the existing definition of stairway, which limited covered stairs to those that have three or more risers. Including a definition in the final rule clarifies the Agency’s intent to cover stairways that have fewer risers.

OSHA adopted the existing definition from national consensus standards in effect in 1971 and those standards have been revised and updated. In particular, the current versions of ANSI/ASSE A1264.1–2007 (Section E6.1) and IBC–2012 (Section 202) specify that a stair has one or more risers. The revision makes the final rule consist with those national consensus standards, which OSHA believes that most employers already follow.

Finally, OSHA adds language to the final definition explaining that stairways include standard, spiral, alternating tread-type, and ship stairs (ship ladders). The existing rule did not include that language.

OSHA did not receive any comments about a definition for “stairway (stairs)” and adopts the definition as discussed.

Standard stairs. The final rule, like the proposal, defines standard stairs as stairways that are fixed or permanently installed. In the preamble to the proposed rule OSHA explained that “permanently installed” standard stairs are interchangeable with the term “fixed” standard stairs. To further clarify the definition, OSHA added this concept.

Existing OSHA standards do not define “standard stairs.” The ANSI/ASSE A1264.1–2007 (Section 6) standard uses the terms “fixed stairs” and “conventional stair designs,” but does not define either term.

Although ship stairs, spiral stairs, and alternating tread-type stairs are fixed or permanently installed stairs, the final definition specifies that they are not considered standard stairs under this subpart.

OSHA did not receive any comments on the proposed definition and finalizes it as discussed above.

Step bolt (pole step). This term means a bolt or rung attached at intervals along a structural member and used for foot placement and as a handhold when climbing or standing. The final definition, like the proposal, also refers to step bolts as “pole steps.” Existing subpart D does not specifically define or address step bolts.

OSHA did not receive any comments on the proposed definition and adopts it as discussed.

Step ladder. This term means a self-supporting, portable ladder that has a fixed height, flat steps, and a hinged back. The final definition consolidates into one term the two existing definitions in existing § 1910.21(c)(2) and (d)(2). The final definition also simplifies the proposed definition by incorporating plain language (fixed height) in place of “non-adjustable in length.”

OSHA did not receive any comments on the proposed definition and adopts it with the clarification discussed above.

Stepstool. This term means a self-supporting, portable ladder that has flat steps and side rails. Similar to the proposed definition, the final rule defines the term “stepstool” to include only those ladders that have a fixed height, do not have a pail shelf, and do not exceed 32 inches in overall height to the top cap, although the side rails may extend above the top cap. The definition goes on to clarify that a stepstool is designed so an employee can climb and stand on all of the steps as well as the top cap. OSHA drew the definition from the construction stairways and ladders standard (§ 1926.1050(b)), ANSI A14.2–2007 (Section 4), and ANSI A14.5–2007 (Section 4), which are similar. The final definition simplifies the proposed term by incorporating plain language “fixed height” in place of “non-adjustable in length,” and reorganizing the definition to make it easier to understand.

OSHA did not receive any comments on the proposed definition and finalizes it with the revisions discussed above.

Through ladder. The final rule, similar to the proposed rule, defines a through ladder as a type of fixed ladder that allows workers to step through the side rails at the top of the ladder to reach a walking-working surface, such as a landing. The final definition is

consistent with the construction standards for stairways and ladders (see § 1926.1050(b)) and ANSI A14.3–2008 (Section 3).

The final definition clarifies the existing rule in § 1910.21(e)(15) and the proposed rule by stating that, at the top of a through ladder, a worker steps off the ladder onto a “walking-working surface,” which may be a landing or another type of surface (e.g., roof); the existing and proposed rules specify stepping onto a landing only.

OSHA did not receive any comments on the proposed definition and adopts it with the clarification discussed above.

Tieback. Similar to the proposed definition, this term means an attachment between an anchorage (e.g., structural member) and a supporting device. The final definition adds language to the proposed definition clarifying that supporting devices include, but are not limited to, parapet clamps or cornice hooks.

According to the International Safety Equipment Association (ISEA), manufacturers provide a number of choices for tieback applications, such as tieback lines or lanyards, and tieback anchors (Ex. 185). ISEA said manufacturers design tieback lanyards for wrapping around a suitable anchor structure (e.g., a beam or structural member), and have the advantage of eliminating a separate component for anchorage connection. ISEA explained that employers typically use tieback lanyards in personal fall arrest systems (Ex. 185).

ANSI/IWCA I–14.1–2001 (Sections 5.7.17, 17.4, and 17.6) notes that the exclusive use of tieback anchors is with tieback lines, not lifelines. The final rule requires that tieback lines and lifelines have separate anchors.

Existing OSHA standards do not define “tieback.” OSHA drew the definition from ANSI A10.8–2011, American National Standard for Construction and Demolition Operations—Safety Requirements for Scaffolding. OSHA believes that adding a definition for “tieback” clarifies the use of the term elsewhere in this subpart. Mr. Hoberg, of DBM Consultants, stated clarification is necessary because various parts of the country use the term differently, and that “each area swears adamantly that theirs is the right one and keeps trying to change the other” (Ex. 206).

The definition is finalized with the clarifying revisions noted above.

Toeboard. The final rule, similar to the proposal, defines this term as a low protective barrier that is designed to prevent materials, tools, and equipment from falling to a lower level, and protect

workers from falling. Typically, employers erect toeboards on platforms, dockboards, catwalks, gridirons, and other elevated or exposed floor level edges. Toeboards, also are referred to as toeplates or kickplates, and may be part of a guardrail system.

The final rule consolidates into one term the three definitions in the existing rule in § 1910.21(a)(9), (f)(31), and (g)(16), all of which are consistent with the final definition. The final rule clarifies that toeboards prevent tools, as well as materials and other equipment, from falling on workers who may be below the elevated walking-working surface.

Finally, and most importantly, OSHA clarifies expressly that toeboards serve two purposes: Preventing materials, tools, and equipment from falling on and injuring workers on a lower level; and protecting workers from falling off elevated walking-working surfaces. The final definition is consistent with OSHA’s construction standard for fall protection in § 1926.500(b) and ANSI/ASSE A10.18–2012 (Section 2.18).

OSHA did not receive any comments on the proposed definition and adopts it with the clarifications discussed above.

Travel restraint system. This definition is new in the final rule. This system is a combination of an anchorage, an anchorage connector, lanyard (or other means of connection), and body support that an employer uses to eliminate the possibility of a worker going over the edge of a walking-working surface.

OSHA drew the definition from final § 1910.140(b). The definition also is consistent with the definition in ANSI/ASSE Z359.0–2012 (Section 2.204), and the definition of the term “restraint (tether) system” in ANSI/ASSE A10.32–2012 (Sections 2.53).

OSHA did not receive any comments on the proposed definition in § 1910.140 and, therefore, adopts a definition as described above for final subpart D. For further discussion about the definition of “travel restraint system,” see the preamble discussion for final § 1910.140.

Tread. The final rule, similar to the proposal rule, defines this term as a horizontal member of a stair or stairway, but does not include landings or platforms. OSHA added clarifying language in the final rule, that landings and platforms, which are horizontal members of stairways, are not considered treads.

The final definition revises the existing and proposed rules by using “stairways or stair” in place of “step.” This revision clarifies that treads

describe horizontal members of stairways. In the existing and proposed rules, treads and steps refer to horizontal members of both ladders and stairways, which OSHA believes may cause confusion. By limiting the term “tread” to stairways or stairs, and the term “step” to ladders, the final rule should resolve any potential confusion.

Treads are measured by their width (side to side) and depth (front to back). OSHA notes that tread depth is measured horizontally between the vertical planes of the foremost projection of adjacent treads, and at a right angle to the tread’s leading edge. This method of measurement is consistent with the NFPA 101–2012 (Section 7.2.2.3.5) and the IBC–2012 (Section 1009.7.2).

The final definition is consistent with ANSI/ASSE A1264.1–2007.1 (Section 2.26). OSHA did not receive any comments on the proposed definition and adopts it as discussed.

Unprotected sides and edges. This term means any side or edge of a walking-working surface, (except at entrances and other points of access) where there is no wall, guardrail system, or stair rail system to protect workers from falling to a lower level. The final definition, which replaces the language “open-sided floors, platforms, and runways” in the existing rule in § 1910.23(c)(1), is consistent with the definition of the term in OSHA construction standards (see §§ 1926.500(b) and 1926.1050(b)).

The final rule revises the proposed definition in two respects. First, it states that a walking-working surface is unprotected if it does not have a stair rail system, in addition to not having a wall or guardrail system as specified in the proposed definition, to protect workers from falling.

Second, OSHA deleted the height-specification language in the proposed rule. This language is not necessary because final § 1910.29, Fall protection systems and falling object protection—criteria and practices, already addresses these height requirements.

OSHA did not receive any comments on the proposed definition and finalizes it with the revisions discussed above.

Walking-working surface. The final rule, similar to the proposal, defines this term as a horizontal or vertical surface on or through which workers walk, work, or gain access to work areas or workplace locations. Walking-working surfaces include floors, stairways, roofs, ladders, runways, ramps, walkways, dockboards, aisles, platforms, manhole steps, step bolts, equipment, trailers, and other surfaces. The existing rule does not define “walking-working

surfaces,” but the final definition is similar to the definition for “walking-working surface” in the construction standard for fall protection in § 1926.500(b), ANSI/ASSE A10.18–2012 (Section 2.20), and ANSI/ASSE A1264.1–2007 (Section 2.28). OSHA notes that, unlike the construction standard for fall protection, the final definition does not exclude “ladders, vehicles, or trailers, on which employees must be located in order to perform their job duties.”

The final rule makes two revisions to the proposed walking-working surface definition. First, the final definition adds “work area” as a location to which a worker may gain access. This revision means that walking-working surfaces include those areas where employees perform their job duties, as well as other locations in the workplace, such as hallways and supply and change rooms. OSHA notes that, for some work and occupations, including equipment service and repair, delivery of materials and supplies, and landscaping, the “work area” may be at various locations. OSHA believes that adding “work area” to the final definition makes it clear what the term covers. The revision also makes the final definition consistent with ANSI/ASSE A1264.1–2007 (Section 2.28).

Second, also consistent with ANSI/ASSE A1264.1–2007, the final rule deletes the list of examples of walking-working surfaces from the proposal. Accordingly, the regulated community is to broadly construe the final definition of “walking-working surface” to cover any surface on or through which employees walk, work, or gain access to a work area or workplace location. Since the final definition does not exclude any walking-working surface, OSHA does not believe that identifying a partial list of surfaces the final rule covers is helpful, necessary, or definitive.

OSHA received several comments addressing the scope of the definition of “walking-working surface,” which it discusses above in the preamble to § 1910.21(a), Scope.

Warning line. This is a new definition OSHA added to the final rule. The term describes a barrier that is erected on a roof to warn workers they are approaching an unprotected side or edge, and which designates an area in which work may take place without using other means of fall protection. The warning line is a component of a designated area, which is an alternative method for preventing falls that the final rule allows employers to use to protect workers on low-slope roofs (see final §§ 1910.28(b)(13) and 1910.29(d)). A

warning line alerts workers that the space marked off by the line is an area where they may work without conventional or additional fall protection (e.g., guardrail, safety net, or personal fall protection system).

Workers may enter the demarcated area only if the employer provides them with the required fall hazard training (see final § 1910.30) and assigns them to work in the demarcated area. In large part, OSHA drew the definition in the final rule from the definition of “warning line system” in the construction standard for fall protection (see § 1926.500(b)).

Although the proposed rule used the term “warning line,” the proposal did not define it. The final rule corrects this oversight. The Agency believes it is important to define the term so that employers and workers understand the new fall prevention method, and so employers may comply with the new warning line requirements.

OSHA did not receive any comments and adopts the definition as discussed above.

Well. Similar to existing § 1910.21(e)(12) and the proposed rule, this term means a permanent, complete enclosure around a fixed ladder. A well surrounding a fixed ladder must provide sufficient clearance to enable the employee to climb the ladder. The terms “well” and “cage” typically are used together because the structures serve the same purpose, *i.e.*, to enclose the climbing area of a fixed ladder. In the event of a fall, wells and cages contain workers within the enclosure and direct them to a lower landing (Ex. 198). ANSI A14.3–2008 (Section 3) also contains a similar definition.

The final rule deletes proposed language stating that “proper clearances for a well provide the person climbing the ladder the same protection as a cage” to prevent employers and workers from mistakenly believing that wells and cages provide fall protection. Information in the record indicates that wells and cages do not protect workers from falling (see, e.g., Ex. 198); as a result, the final rule in § 1910.28(b)(9) phases out their use as fall protection systems.

OSHA did not receive any comments on the proposed definition and adopts the term with the revision discussed above.

Other issues. Two commenters suggested that OSHA include additional definitions in the final rule. First, Nigel Ellis recommended that OSHA add a definition for the term “cover” to the final rule, stating:

The word Cover is not presently defined as to adequacy and walkability in the May 2010

standard proposal. A cover may be a plywood board or perhaps OSB or temporarily and more dangerously a section of drywall to keep out dust and weakens when wet. The new to America Platform Nets should be accommodated for maintenance work to allow walkable fabric covers to be used for walking across holes and open spaces.

* * * * *

The term cover should be defined on a structural level applicable to any unit skylight, including plastic, light transmitting pane and smoke vent and where it is either a board, fabric, fall protection net, walkable net, skylight with structural members impervious to the effects of UV sunlight, screen, grill and should be tested for impacts with humans (Ex. 155).

OSHA believes employers understand the meaning of cover; therefore, it is not necessary to add a definition to the final rule.

Second, Mercer ORC requested that OSHA define the term “chain gate” and identify how it differs from the term “swinging gate” (Ex. 254). The reference to chain gate in proposed § 1910.29(b)(10) was a typographical error that inadvertently omitted the comma between chain and gate. Given that, there is no need to add a definition for either chain gate or swinging gate.

Section 1910.22—General Requirements

Final § 1910.22 revises and updates the existing requirements that apply to surfaces in general industry. These provisions address:

- Surface conditions and housekeeping (paragraph (a));
- Application of loads on walking-working surfaces (paragraph (b));
- Access to and egress from walking-working surfaces (paragraph (c)); and
- Inspection, maintenance, and repair of walking-working surfaces (paragraph (d)).

In general, the final rule revises the existing requirements in several ways. First, final § 1910.22, as well as all other sections of final subpart D, uses the term “walking-working surface.” Final § 1910.21(b) defines walking-working surface as any horizontal or vertical surface on or through which an employee walks, works, or gains access to a workplace location. Walking-working surfaces include, but are not limited to, floors, stairways, roofs, ladders, runways, walkways, dockboards, aisles, and step bolts.

In final § 1910.22, as in other sections of final subpart D, OSHA revised the existing language so it is performance-based and easier to understand, consistent with the OSH Act (29 U.S.C. 655(b)(5)), and the Plain Language Act of 2010 (Pub. L. 111–274; see also E.O. 13568 (1/18/2011)), respectively. OSHA

believes the revised language provides greater flexibility for employers, and makes it easier for them to comply with the final rule.

OSHA also moved or deleted provisions in existing § 1910.22 that address specific issues or hazards rather than general conditions. For example, OSHA moved the existing guardrail and covers requirements (existing § 1910.22(c)) to final §§ 1910.28 (Duty to have fall protection), and 1910.29 (Fall protection systems criteria and practices). OSHA believes that the existing provision, which addresses two specific types of fall protection measures, is more appropriately grouped with the other fall protection measures. In addition, OSHA deleted the requirements on mechanical-handling equipment in existing paragraph (b) because § 1910.176(a) addresses that issue.

Paragraph (a)—Walking-Working Surfaces

Final paragraph (a), like the existing and proposed rules, contains general requirements on housekeeping and walking-working surface conditions. Pursuant to section 6(a) of the OSH Act (29 U.S.C. 655(a)), OSHA adopted most of the requirements in existing paragraph (a) from the ANSI standard in effect in the early 1970s (ANSI Z4.1–1968, Requirement for Sanitation in Places of Employment (Z4.1–1968)). Although ANSI updated the Z4.1 standard several times since 1968 (see ANSI Z4.1–1986 (R2005) (Z4.1–R2005)), OSHA did not update the requirements until this rulemaking.

Final paragraph (a)(1), consistent with the existing and proposed rules, requires that employers ensure surfaces are kept in a clean, orderly, and sanitary condition in “[a]ll places of employment, passageways, storerooms, service rooms, and walking-working surfaces.” Final paragraph (a)(1) also is consistent with Z4.1–R2005 (Section 3.1.1). OSHA adds the term “walking-working surfaces” to the provision to eliminate any confusion about the surfaces the final rule is intended to cover.

In the preamble to the proposed rule, OSHA explained its longstanding position that § 1910.22(a), especially § 1910.22(a)(1), covers hazards other than slips, trips, and falls, and includes fire and explosion resulting from combustible dust accumulations (see 75 FR 28874). Prior court decisions uphold OSHA’s interpretation, saying “the housekeeping [§ 1910.22(a)] standard is not limited to tripping and falling hazards, but may be applied to significant accumulation of combustible

dust” (*Con Agra, Inc. v. Occupational Safety and Health Review Commission*, 672 F.2d 699, 702 (8th Cir. 1982), citing *Bunge Corp. v. Secretary of Labor*, 638 F.2d 831, 834 (5th Cir. 1981)). In *Pratt & Whitney Aircraft* (9 O.S.H. Cas. (BNA) 1653, 1981 O.S.H.D. (CCH) P 25359, 1981 WL 18894 (O.S.H.R.C.)), the Occupational Safety and Health Review Commission (Review Commission) reached the same conclusion on a converse set of facts. Pratt & Whitney argued that § 1910.22(a)(1) only covered “sanitation and the prevention of disease,” not trip hazards. The Review Commission rejected that argument, saying the standard’s requirement that employers keep places of employment “in a sanitary condition” is “in addition to the requirement that workplaces be ‘clean and orderly,’ thus demonstrating that the standard is directed not merely to sanitation but to all hazards arising from poor housekeeping, including tripping hazards.” (See also, *Farmer’s Co-op*, 1982 WL 2222661 (O.S.H.R.C.); *CTA Acoustics* (KY 2003), CSB Report No. 2003–09–I–KY (February 2005); *Hayes Lemmerz International* (Indiana 2003), CSB Report No. 2004–01–I–IN (September 2005).)

As these cases show, § 1910.22(a)(1) serves as an important enforcement tool for preventing hazardous combustible dust accumulations on walking-working surfaces. Moreover, in essentially every document addressing combustible dust that OSHA released since *Bunge*, the Agency affirmed that its combustible dust enforcement strategy includes citing housekeeping violations (*i.e.*, failure to control combustible dust accumulations) under § 1910.22(a)(1). (See *e.g.*, “Combustible Dust in Industry: Preventing and Mitigating the Effects of Fire and Explosion,” OSHA Safety and Health Information Bulletin (SHIB) 07–31–2005, (2005, July 31)¹³; “Hazard Alert: Combustible Dust Explosions,” OSHA Fact Sheet (March 2008)¹⁴; OSHA Compliance Directive CPL–03–00–008, “Combustible Dust National Emphasis Program,” (March 11, 2008) (replacing CPL 03–00–006, “Combustible Dust National Emphasis Program,” October 18, 2007)¹⁵; and “Status Report on Combustible Dust

National Emphasis Program,” (October 2009)).¹⁶

In the proposed rule, OSHA requested comment on whether the Agency should include a specific reference to combustible dust or other types of dust or materials in final § 1910.22(a) to clarify explicitly that the provision does, and will continue to, cover combustible dust hazards. OSHA received many comments. Two commenters, United Food and Commercial Workers (UFCW) (Ex. 159) and the American Federation of Labor and Congress of Industrial Organizations (AFL–CIO) (Exs. 172; 329 (1/20/2011, p. 219); 363) supported including a specific reference in both final § 1910.22(a)(1) and (a)(2). Bill Kojola of the AFL–CIO said: “While agency interpretations to include combustible dust have proven useful to address this hazard, we believe an explicit referencing of combustible dust within each of these paragraphs is necessary to * * * let employers know with explicit certainty that combustible dust is covered by these provisions” (Ex. 172). UFCW, which said it represents food plants, including sugar, corn, flour-milling, and cocoa plants, explained: “The food dusts in these plants can be combustible.

Housekeeping—keeping combustible dust from accumulating on floors and other surfaces and keeping surfaces as free from dust as possible—is a critical aspect to mitigating and preventing combustible dust explosions” (Ex. 159).

However, most commenters, for various reasons, opposed including a specific reference to combustible dust in final § 1910.22(a) (Exs. 73; 96; 124; 148; 158; 166; 173; 186; 189; 190; 202; 207; 254). First, many commenters seemed to think that existing § 1910.22(a)(1) does not cover combustible dust, and that OSHA is aiming to add it to the final rule as part of this rulemaking (Exs. 73; 96; 124; 148; 158; 166; 202). For example, several commenters said that § 1910.22(a) and this rulemaking focus, and should focus, on preventing slips, trips, and falls, which is not the primary hazard of combustible dust (Exs. 73; 96; 124; 158; 166; 190; 207; 254). The United States Beet Sugar Association (USBSA) and National Grain and Feed Association (NGFA), citing a 1978 OSHA Memorandum, also argued that OSHA is uncertain whether § 1910.22(a) applies to combustible dust because the Agency instructed its compliance officers to cite § 1910.22(a)(1) and

¹³ Combustible Dust in Industry: Preventing and Mitigating the Effects of Fire and Explosion available from OSHA’s Web site at: <http://www.osha.gov/dts/shib/shib073105.html>.

¹⁴ Hazard Alert: Combustible Dust Explosions available from OSHA’s Web site at: http://www.osha.gov/OshDoc/data_General_Facts/OSHACombustibleDust.pdf.

¹⁵ Combustible Dust National Emphasis Program available from OSHA’s Web site at: http://www.osha.gov/pls/oshaweb/owadisp.show_document?p_table=DIRECTIVES&p_id=3830.

¹⁶ Status Report on Combustible Dust National Emphasis Program available from OSHA’s Web site at: http://www.osha.gov/dep/combustible_dust/combustible_dust_nep_rpt_102009.html.

Section 5(a)(1) of the OSH Act, in the alternative, for grain-dust accumulations (Exs. 148; 166).

These commenters are mistaken. As described in detail above, OSHA has for more than 30 years interpreted § 1910.22(a)(1) as applying to combustible dust hazards, and the courts have upheld this interpretation. In the 2009 “Status Report on Combustible Dust National Emphasis Program,” OSHA noted that housekeeping violations (§ 1910.22(a)(1)) accounted for 20 percent of the violations involving combustible dust, second only to hazard communication violations. In the Advance Notice of Proposed Rulemaking on combustible dust, OSHA also stated that existing § 1910.22(a) covers “accumulation of dust, including dust that may be combustible” (74 FR 54334, 54335 (October 21, 2009)). Therefore, regardless of whether OSHA includes a specific reference to combustible dust in final § 1910.22(a)(1), OSHA’s enforcement policy remains the same.

With regard to USBSA’s and NGFA’s “uncertainty” argument, the 1978 memorandum they cite has not been OSHA’s policy since 1981, when the courts and the Review Commission upheld OSHA’s interpretation that § 1910.22(a)(1) covers combustible dust.

Second, a number of commenters cited OSHA’s ongoing combustible dust rulemaking as a reason why the Agency should not reference combustible dust in final § 1910.22(a)(1) (Exs. 73; 96; 124; 158; 189; 190; 202; 207; 254). The National Federation of Independent Business (NFIB) said that including a reference to combustible dust in final § 1910.22(a) would “create confusion for small businesses when the combustible dust rule is finalized” (Ex. 173). The Small Business Administration Office of Advocacy (SBA Advocacy) said that § 1910.22(a) is so vague that “it would undo any specificity in any forthcoming combustible dust standard” (Ex. 124). USBSA agreed, stating that including a reference to combustible dust in § 1910.22(a)(1) “would significantly undermine the usefulness of a combustible dust rule” and “would swallow up and nullify whatever specificity is provided by a comprehensive combustible dust standard” (Ex. 166).

The National Cotton Ginners’ Association (NCGA), the Texas Cotton Ginners Association (TCGA), and American Feed Industry Association (AFIA) said including combustible dust in § 1910.22(a)(1) would be “redundant and possibly conflicting” when OSHA “re-regulate[s] these same dusts in the

future under the combustible dust rule” (Exs. 73; 96; 158).

OSHA believes these arguments are premature since OSHA’s Spring 2016 Unified Agenda of Regulatory and Deregulatory Actions (Reg Agenda) states that combustible dust is in the Prerule Stage.¹⁷ However, as OSHA proceeds with a rulemaking on combustible dust, the Agency will evaluate carefully the relationship between § 1910.22(a)(1) and a combustible dust rule to avoid any conflicts.

Third, on a related issue, some commenters contend that OSHA must regulate combustible dust in a separate rulemaking. The United States Chamber of Commerce (USCC) said a separate rulemaking is necessary because combustible dust is a complex, multi-variable hazard that is “not amenable to a simple characterization” and does not have a consensus definition: “Merely telling employers that the walking/working surfaces are not to have a level of dust that would be combustible gives them no guidance, serves no workplace safety purpose, and will only lead to OSHA having another source for citations” (Ex. 202).

USBSA said a separate standard was necessary because § 1910.22(a)(1) and (2) do not address issues such as “[h]ow much [combustible dust] is too much?”; “[w]hat must an employer do at what dust level?”; and “[s]hould all combustible dusts be treated the same?” (Ex. 166).

NFIB also said a separate rulemaking on combustible dust is necessary because OSHA “does not understand the implications of [final § 1910.22(a)(1)] on small businesses” (Ex. 173). NFIB said that OSHA incorrectly certified in the proposed rule that the rulemaking would not have a significant economic impact on small businesses, thereby avoiding the requirement to convene a Small Business Advisory Review (SBAR) panel. As a result, NFIB said OSHA underestimated the proposed compliance costs, and that regulating combustible dust in a separate rulemaking would allow OSHA to hear from a SBAR panel and “fully grasp the burden” that a combustible dust rule will impose on small business (Ex. 173).

OSHA disagrees with the commenters. As noted above, for more than 30 years, OSHA has used § 1910.22(a)(1) as an effective enforcement tool in general industry

establishments of all sizes to address fire and explosion hazards related to combustible dust accumulations. This earlier discussion also mentioned that the 2009 Status Report on the Combustible Dust NEP determined that 20 percent of all combustible dust-related violations pertained to housekeeping (§ 1910.22(a)(1)). This history indicates that combustible dust is not too complex to enforce under existing rules.

With regard to NFIB’s contention that the proposed rule underestimated compliance costs, OSHA points out that § 1910.22(a)(1) already covers combustible dust. Accordingly, in the proposed economic analysis, OSHA did not have to include any costs for the combustible dust requirement or any other existing applicable requirement.

Fourth, some commenters said including a reference to combustible dust in final § 1910.22(a)(1) is invalid because the national consensus standard (ANSI Z4.1–1968) from which OSHA adopted § 1910.22(a)(1), pursuant to section 6(a) of the OSH Act, applied only to “sanitation” and sanitary conditions (*i.e.*, “the physical condition of working quarters which will tend to prevent the incidence and spread of disease” (ANSI Z4.1–1968 (Section 2))) and, therefore, did not apply to combustible dust (Exs. 124; 166; 190). USBSA pointed out that a statement in ANSI Z4.1–1968 described the purpose of the standard as follows: “The purpose of this standard is to prescribe minimum sanitary requirements for the protection of the health of employees in establishments covered by this standard” (ANSI Z4.1–1968 (Section 1.2)). USBSA contends that OSHA’s omission of this ANSI purpose statement was “unlawful” (Ex. 166). As such, USBSA maintains that OSHA is bound by the scope and purpose of the 1968 ANSI standard, and the only permissible way OSHA could add combustible dust to § 1910.22(a)(1) was by notice-and-comment rulemaking. To bolster its argument, USBSA also includes in its comments a declaration from William Carroll, Executive Director of the Portable Sanitation Association International, which was the sponsoring organization for ANSI Z4.1–1968; Mr. Carrol stated that ANSI did not develop Z4.1–1968 to cover fire and explosion from combustible dust.

OSHA does not agree with USBSA’s arguments. Under section 6(a), OSHA “is not bound to adopt all provisions of national consensus standards,” and that not adopting the scope and purpose provisions “[does] not constitute impermissible modification” of the requirements of a national consensus

¹⁷ See OSHA’s Spring 2016 Reg Agenda on Combustible Dust at: <http://www.reginfo.gov/public/do/eAgendaViewRule?pubId=201604&RIN=1218-AC41>.

standard (*Secretary of Labor v. C.R. Burnett and Sons*, 9 O.S.H. Cas. (BNA) (O.S.H.R.C. (October 31, 1980) (the Review Commission rejected the employer's argument that OSHA was bound by the scope of another ANSI sanitation standard (ANSI Z4.4-1968, Sanitation—In Fields and Temporary Labor Camps—Minimum Requirements) adopted pursuant to section 6(a)).

Accepting USBSA's position that § 1910.22(a)(1) only addresses sanitation hazards would mean that OSHA could not use § 1910.22(a)(1) to cite slip, trip, and fall hazards because they are not sanitation hazards. USBSA does not mention that incongruous outcome in its comments, but instead selectively addresses a specific hazard it does not want OSHA to cite under the final rule.

However, previous decisions by the Review Commission and courts of appeal broadly construe § 1910.22(a)(1) (*Whirlpool Corp. v. Marshall*, 445 U.S. 1, 13, 100 S.Ct. 883, 891, 63 L.Ed.2d 154 (1980) ("To promote this remedial purpose of the statute, the Act and regulations must be liberally construed so as to afford workers the broadest possible protection"); *National Eng'g & Contracting Co. v. OSHA*, 928 F.2d 762, 767 (6th Cir. 1991)). In *Bunge* (638 F.2d at 834), the court opined: "The type of hazard . . . is irrelevant to whether some condition or practice constitutes a violation of [§ 1910.22(a)(1)]. Unless the general standard incorporates a hazard as a violative element, the prescribed condition or practice is all that the Secretary must show."

In *Whitney & Pratt Aircraft* (1981 W-L 18894), the Review Commission said:

We reject Pratt & Whitney's contention that the scope of [§ 1910.22(a)(1)] is limited to disease prevention and does not encompass tripping hazards. The standard's requirement that places of employment be kept 'in a sanitary condition' is in addition to the requirement that workplaces be 'clean and orderly', thus demonstrating that the standard is directed not merely to sanitation but to all hazards arising from poor housekeeping, including tripping hazards.

OSHA notes that, contrary to Mr. Carroll's declaration, ANSI Z4.1-1968, on its face, covers hazards other than sanitation hazards. The standard contains several provisions that do not relate to sanitation, including lighting; keeping workplaces in an orderly condition; and maintaining workplaces free from protruding nails, holes, and loose boards.

Fifth, NGFA (Ex. 148) and AFIA (Ex. 158) recommended that OSHA not include a reference to combustible dust in § 1910.22(a)(1) because it would subject their industry to "duplicative

and unnecessary requirements" that OSHA's Grain Handling Facilities standard (§ 1910.272) already addresses and, therefore, would cause confusion. They said § 1910.272, along with section 5(a)(1) (29 U.S.C. 654(a)(1)), is working effectively in controlling grain dust hazards, which obviates the need for additional regulation.

AFIA pointed out that the number of fatalities from explosions involving combustible dust declined dramatically in the industry since 1980 (Ex. 158). AFIA maintains that a number of factors contributed to reducing the frequency and severity of these occurrences, including widespread voluntary efforts by industry and trade organizations to increase awareness, research into and implementation of new engineering controls, employee training, and automation that reduces workforce exposure to explosion hazards from combustible dust. Although the Grain Handling Facilities standard issued by OSHA in 1987 (§ 1910.272) may account for some of the reduction in explosions, notably grain-mediated combustible-dust explosions, it was not in effect in the early 1980s, the initial explosion reduction timeframe AFIA cites. Only the court and the Review Commission decisions affirming OSHA's interpretation that § 1910.22(a)(1) applies to combustible dust hazards were in effect in 1981 and 1982. Given that, OSHA believes that it is reasonable to infer that § 1910.22(a)(1) contributed to reducing the number of explosions and fires involving combustible dust during the early 1980s. For all these reasons, OSHA continues to apply § 1910.22(a)(1) to grain-handling facilities.

Finally, USBSA explained that referencing combustible dust in § 1910.22(a)(1) could conflict with §§ 1910.307 (Electrical-Hazardous (classified) locations) and 1910.178 (Powered industrial trucks), stating:

[A]pplying those provisions with a reference to combustible dust would undermine what little specificity already exists in the current standards addressing combustible dust. For example, applying them would significantly undermine the existing distinctions between unclassified, Class II, Division 1, and Class II, Division 2, areas in 29 C.F.R. 1910.307 and 1910.178, which specify where and under what circumstances approved electrical equipment and forklift trucks are required in dusty conditions. There is no point in specifying what electrical equipment and forklift trucks are required under dusty conditions if those conditions are illegal in the first place under § 1910.22(a) (Ex. 166).

In response, OSHA reiterates that § 1910.22(a)(1) already applies to combustible dust. Existing § 1910.22(a)

generally addresses combustible dust hazards on walking-working surfaces, while §§ 1910.307 and 1910.178 address more specific combustible dust hazards related to electric equipment and powered industrial trucks, respectively, and OSHA finds no indication that they conflict with each other. Moreover, the Agency has not experienced any conflicts enforcing those requirements.

Final paragraph (a)(2), like the existing and proposed rules, requires that employers ensure the floor of each workroom is maintained in a clean and, to the extent feasible, in a dry condition. The final rule is similar to OSHA's housekeeping requirements in its Shipyard Employment standards (§ 1915.81(c)(3)) and Z4.1-R2005 (section 3.1.2). OSHA believes it is important for employers to maintain walking-working surfaces in a clean and dry condition to protect workers from possible injury from slips, trips, and falls and other hazards.

Final paragraph (a)(2) also requires that employers take additional action if they cannot keep workroom floors in a dry condition. OSHA notes this provision only requires employers to take additional actions when they are using "wet processes." When wet processes are used, the final rule requires that drainage is maintained and, to the extent feasible, dry standing places are provided, such as false floors, platforms, and mats. Final paragraph (a)(2) provides examples of measures employers can use to provide workers with dry standing places, such as false floors, platforms, and mats, but gives employers flexibility to select other measures that are effective in providing dry standing places. OSHA believes this provision is necessary to protect workers from slips, trips, falls, and other hazards on wet surfaces.

The American Meat Institute (AMI) commented on the proposed rule:

In the meat industry, as in several others, there is simply no possible way to maintain floors in a "dry condition" in areas such as slaughter departments, vat/bin washing rooms, during sanitation operations, etc. And, providing false floors, mats, platforms, etc., though done where possible, is not practical in all areas. Stated simply, there are many cases where floors in operating areas will be "wet" throughout the working shift. However, it should be recognized that "wet" is a relative term; there is significant difference between standing water of some depth as opposed to simply damp surfaces (Ex. 110).

AMI recommended that the final rule make a distinction between wet floors where there is standing water and floors that are "continuously damp" because of periodic cleaning or rinsing, stating:

“We . . . submit that while wet floors may pose potentially unique and specific hazards, damp floors typically pose minimal hazard and do not require additional, specific regulation” (Ex. 110). OSHA disagrees with AMI’s recommendation that the final rule should make a distinction between working in “standing water,” which AMI defines as greater than one inch deep, and working on wet surfaces. Accordingly, OSHA believes that both working on wet surfaces and working in standing water are hazardous and pose a risk of slips, trips, falls, or other harm (e.g., electrocution, prolonged standing in water). Final paragraph (a)(2) gives employers a great deal of flexibility to tailor their control measures to the type of wet conditions present in the particular workplace, thereby making it easier for employers to comply with the requirement.

In the proposed rule, OSHA requested comment on whether final paragraph (a)(2) should include a provision, similar to that in Shipyard Employment (29 CFR 1915.81(c)(3)), requiring that, in wet processes, employers provide appropriate waterproof footwear, such as overboots, when it is not practicable to maintain drainage and dry standing areas (75 FR 28874). OSHA received three comments in response to this request, all of which opposed adding that provision to the final rule. Edison Electric Institute (EEI) (Ex. 207) and the American Wind Energy Association (AWEA) (Ex. 178) both said that employers should determine whether a hazard exists that necessitates use of personal protective equipment (PPE) and select the best method to prevent slips, trips, and falls on wet surfaces. UFCW raised concerns that allowing the use of PPE would cause employers to use PPE instead of following the hierarchy of controls:

By specifically offering the employer the option of providing PPE, OSHA will have the unintended effect of negating the original requirement to eliminate the hazard or control it through engineering controls. We have seen a similar unfortunate dynamic in the implementation and enforcement of 1910.95(b)(1) which supposedly allows the use of PPE *only after* the implementation of feasible administrative and engineering controls. Our experience with the noise standard has been that once excessive sound levels have been determined, most employers embrace the use of hearing protection, and the implementation of engineering controls is perfunctory or ignored altogether (Ex. 159).

UFCW also noted, correctly, that it was not necessary for OSHA to reference PPE in the final rule because, under § 1910.132(a), employers already must provide PPE for hazards that they

cannot eliminate or control by other methods (Ex. 159).

OSHA finds the commenters’ arguments convincing and, therefore, did not add the language in § 1915.81(c)(3) to the final rule. In particular, OSHA agrees with the concerns UFCW raised about the hierarchy of controls, and reaffirms that employers must provide dry standing places, and maintain drainage using engineering controls, to the extent such controls are feasible.

Final paragraph (a)(3), which OSHA revised significantly from the proposed rule, requires employers to ensure walking-working surfaces are maintained free of hazards such as loose boards, corrosion, leaks, spills, snow, ice, and sharp or protruding objects.

In general, OSHA revised the language in final paragraph (a)(3) to more clearly and specifically reflect the type and nature of the hazards the Agency intended to address in this provision. The revisions serve two purposes. First, the revisions clarify that a major focus of final subpart D is to protect workers from walking-working surface hazards that could cause or exacerbate the severity of a slip, trip, or fall. For example, if employers do not maintain walking-working surfaces free of leaks, spills, and ice workers could slip and fall and be seriously injured. Similarly, if unused tools (e.g., saws, shears), materials (e.g., unused pallets, bailing wire), or solid waste or debris (e.g., scrap metal) are left on surfaces where employees work or walk, workers could be seriously hurt if they fell on any of those objects. In addition, in some situations, corrosion may be so severe or significant that it may weaken the walking-working surface to the point that the surface can no longer support a worker, equipped with tools, materials, and equipment, who walks or works on it.

Second, it emphasizes OSHA’s longstanding position, supported by the court decisions noted previously, that the scope of § 1910.22, and paragraph (a)(3) specifically, also covers walking-working surface hazards other than slips, trips, and falls. For example, a nail protruding from a wall may not cause a slip, trip, or fall, but could cause a serious laceration or puncture wound if a worker walks into or bumps into it. Similarly, if employers do not ensure the immediate removal of caustic chemicals or substances spilled onto a walking-working surface, workers may be at risk of adverse effects, such as chemical burns, if they accidentally touch the substance.

The existing rule, which OSHA adopted from the Z4.1–1968 standard,

requires that employers, to facilitate cleaning, keep every floor, working place, and passageway free from “protruding nails, splinters, holes, or loose boards.” In the proposed rule, OSHA decided to revise existing paragraph (a)(3) to emphasize that the examples of the hazards listed can result in more than slips, trips, and falls, and are present in more than cleaning operations. Therefore, OSHA replaced the existing examples of specific hazards with performance-based language, stating, “Employers must ensure that all surfaces are designed, constructed, and maintained free of recognized hazards that can result in injury or death to employees,” and deleted the existing “[t]o facilitate cleaning” language.

Many commenters opposed proposed paragraph (a)(3). Most argued that the performance-based language “free of recognized hazards” was vague, overly broad, and appeared to duplicate the General Duty Clause of the OSH Act (Exs. 124; 150; 165; 173; 190; 196; 236). For example, the Sheet Metal and Air Conditioning Contractors National Association (SMACNA) said: “[P]roposed section 1910.22(a)(3) . . . appears to be a ‘General Duty Clause’ specific to this standard . . . and does not offer any logical means of compliance. . . . [T]he proposed requirement is open-ended and provides very little guidance to address any particular hazard” (Ex. 165). The Mechanical Contractors Association of America (MCAA) expressed similar concerns about the language and how OSHA would enforce it:

[T]he general duty clause-like language proposed . . . as 29 CFR 1910.22(a)(3) would allow compliance officers to issue general duty clause-like citations without having to meet the extensive and elaborate criteria established by the agency for issuing general duty clause citations. MCAA believes that this language would cause confusion, dissent and controversy without enhancing worker protection (Ex. 236).

The American Foundry Society (AFS) said the provision was “so vague and open-ended that it could leave employers vulnerable to OSHA citations based on the subjective assessment of OSHA inspectors as to what is acceptable,” and would place “an impossible obligation on employers by short-circuiting the requirements” of the General Duty Clause (Ex. 190).

NFIB raised three concerns about proposed paragraph (a)(3). First, NFIB pointed out that the proposed rule does not define “recognized hazards,” saying “[t]he term may have a different meaning to a small business owner than it does to an OSHA inspector” (Ex. 173).

Second, they said the proposed rule is “impossible to meet” and “virtually meaningless for compliance purposes,” noting:

This standard, as written, is so broad that it could be inferred by an inspector or judge that if any injury occurs—for any reason—the employer can be cited for failure to comply. The presumption is that a small business owner should foresee all possibilities of injuries, even in the most remote of circumstances (Ex. 173).

Finally, NFIB said the proposed requirement could result in a small business being “cited twice for the same violation—opening the business up to excessive fines and penalties” (Ex. 173).

According to SBA Office of Advocacy, small businesses attending their forum on the proposed rule expressed concerns that OSHA would use the proposed rule to impose a “‘de facto’ Safety and Health Program (S&HP) or Injury and Illness Prevention Program (I2P2) requirement on employers” (Ex. 124). Therefore, SBA Office of Advocacy and Associated Builders and Contractors (ABC), who raised similar concerns, recommended that OSHA clarify the regulatory language, as well as the purpose of the requirement in the final rule (Exs. 124; 196).

The commenters raise valid concerns. The purpose of the proposed requirement was not to codify the General Duty Clause as a standard or reduce OSHA’s burdens in proving a General Duty Clause violation. Rather, as explained above, the purpose was to use performance-based language to point out that failure to adequately clean and maintain walking-working surfaces: (1) Can make slips, trips, and falls more severe, and (2) can result in adverse effects other than slips, trips, and falls (e.g., burns from exposure to corrosive materials). The revised language in final paragraph (a)(3) ensures that stakeholders understand that the final rule covers both types of hazards. Also, adding specific examples, such as those in the existing rule, ensures stakeholders that the final rule focuses on the types of hazards associated with walking-working surfaces instead of all “recognized hazards that can result in injury or death” as the proposed rule specified. Therefore, the final rule stresses that employers’ housekeeping efforts must take into account walking-working surface hazards other than simply those associated with slips, trips, and falls.

Mr. Lankford recommended removing the design and construction requirements in proposed paragraph (a)(3) because they would impose “significant responsibility on employers” in the many instances when

“[t]here is no connection between the designer/builder and the current employer” (Ex. 368). In the hearing, Mr. Lankford said OSHA should allow employers to comply with the requirement by confirming that the walking-working surfaces “were built according to the standard or local building code” (Ex. 329 (1/20/2011, p. 297)). OSHA agrees, and removed the design and construction requirements in final paragraph (a)(3).

On a separate issue, Ellis Fall Safety Solutions suggested that OSHA add a requirement to § 1910.22(a) that walking-working surfaces be “walkable from a body space point of view,” meaning an employee in the 95th height percentile should be able to walk upright without encountering head or other obstructions (Ex. 155). OSHA believes the performance-based requirements in final paragraph (a)(3) takes this issue into account in an effective way. Paragraph (a)(3) requires that employers maintain walking-working surfaces free of protruding objects that could harm workers, regardless whether the worker is tall or large.

Michael Bell of Joneric Products, a footwear manufacturer, objected to the scope of OSHA’s benefits policy:

This Proposed Rule virtually ignores fatalities and injuries that occur not from heights. There are some easy solutions to remedy these fatalities and injuries.

1. Recognize that workers whose primary job is to wash, wax or maintain floors are at high risk of slips and falls. There are companies that manufacture specialized footwear for these activities.
2. Recognize that many workers primarily work outdoors. Most of them must work on Public Property. Even though OSHA has no authority to tell a private citizen how to maintain their properties at least admit that many injuries do occur outdoors and they are reportable to OSHA.
3. Recognize that inclement weather is the cause of a good many of these injuries.
4. Know that this is serious enough that many companies are proactive in attempting to reduce these weather related injuries. But, they do not make up for the companies that ignore the situation because there is [sic] no OSHA regulations.
5. Companies have a wide range of products to choose from many manufacturers (Ex. 77).

OSHA agrees with Mr. Bell’s statement and notes that the provisions in § 1910.22(a)(1)–(3) address slips and falls to the same level. In particular, OSHA notes that these final provisions will require employers to control worker exposure to fall hazards on outdoor surfaces.

Final Paragraph (b)—Loads

Final paragraph (b) requires that employers ensure each walking-working surface can support the “maximum intended load” for that surface. The final rule, like the proposal defines maximum intended load as the total weight of all employees, equipment, machines, vehicles, tools, materials, and loads that employers reasonably anticipate they may be apply to that walking-working surface. The existing rule includes a similar provision requiring that employers not place on a floor or roof any load weighing more than the building official has approved for the surface (existing § 1910.22(d)(2)). The construction fall protection standard also requires that employers “determine if walking/working surfaces on which its employees are to work have the strength and integrity to support employees safely” and only allow employees to work on surfaces that meet the requirement (29 CFR 1926.501(a)(2)).

Final paragraph (b), like the proposal, specifies that it covers all walking-working surfaces; that is, “any horizontal or vertical surface on or through which an employee walks, works, or gains access to a workplace location” (see final § 1910.21(b)). Accordingly, employers must ensure that all walking-working surfaces, which include, but are not limited to, floors, roofs, stairs, ladders, and ramps; can support the maximum intended load. The existing rule specifies it applies to “any floor or roof” of a building or other structure (existing § 1910.22(d)(2)). Final paragraph (b) also replaces the specification requirements in existing § 1910.22(d)(1) with performance-based language. The existing rule specifies that the loads the building official approves for a specific walking-working surface “shall be marked on plates of approved design . . . and securely affixed . . . in a conspicuous place in the space to which they relate.”

In the proposed rule, OSHA said the existing specification requirement was not necessary for two reasons: (1) Load-limit information is available in building plans, and (2) engineers take maximum loads into consideration when they design industrial surfaces. OSHA proposed to replace the existing rule with provisions requiring that employers ensure that walking-working surfaces are “[d]esigned, constructed, and maintained to support their maximum intended load” (proposed paragraph (b)(1)), and “[n]ot loaded beyond their maximum intended load” (proposed paragraph (b)(2)).

OSHA received three comments on the proposal. The first commenter, AFSCME, recommended requiring that employers ensure all walking and working surfaces have the “structural integrity” to support the workers, their tools and equipment. OSHA believes that requiring employers to ensure each surface is capable of supporting the maximum intended load, as defined in final § 1910.22(b), achieves the result AFSCME advocates. The definition of “maximum intended load” in final § 1910.21(b) includes the total weight of all employees, equipment, machines, vehicles, tools, materials, and loads that the employer reasonably anticipates may be applied to the walking-working surface.

The second commenter, Charles Lankford, objected to the proposed requirement that employers ensure walking-working surfaces are “designed and constructed” to support their maximum intended load (proposed paragraph (b)(1)):

[E]mployers will be unable in most cases to ensure positively that existing or newly purchased walking and working surfaces were “designed and constructed” (perhaps decades earlier) to comply with this standard.

Employers will for practical purposes be limited to relying on third party certification, testing, listing, and/or labeling of platforms and surfaces such as scaffold planks, floors of crane cabs, runways, etc. However, OSHA did not state in the proposed rule that reliance on third party certifications would be a method of compliance or could be a valid defense from citations (Ex. 368; *see also* Ex. 329 (1/20/2011, p. 295)).

OSHA disagrees with Mr. Lankford’s contention. The existing rule makes it easy for employers to know for certain whether a walking-working surface on an existing building or structure can support the maximum intended loads employers anticipate placing on that surface. The existing rule requires that load limits for buildings and structures used for mercantile, business, industrial, or storage purposes: (1) Be approved by the building official; and (2) be posted in the area of the walking-working surface (existing § 1910.22(d)(1)). The existing rule also prohibits employers from putting any load on a walking-working surface that exceeds the weight the building official has approved. Under the final rule, employers can readily obtain information about walking-working surfaces in those buildings and structures from the plates required to be posted in accordance with the existing rule. For new buildings and structures, employers can obtain information on load limits from building plans, local

codes, and third party certification or conduct their own evaluation.

Mr. Lankford is correct that the proposed rule, as well as the final rule, does not state specifically how employers must obtain information about load limits for a walking-working surface. However, OSHA believes there are many ways employers can obtain such information. Mr. Lankford provided examples of several methods employers may use, including obtaining load limits from the plates posted in the area; relying on third party certification; and testing or evaluating walking-working surfaces. Instead of codifying the methods Mr. Lankford mentioned, OSHA has used performance-based language in the final rule to give employers greater flexibility in selecting the method they want to use to identify whether the walking-working surface can support the maximum intended load employers will place on it.

Finally, the National Chimney Sweep Guild (NCSG) contended the requirement that employers ensure each walking-working surface can support the maximum intended load they will apply to it is not feasible and, as proposed, go beyond what is reasonably necessary or appropriate (Exs. 150; 240; 365; 329 (1/18/2011, p. 254–348)). First, NCSG said that chimney sweeps are not able to determine the “maximum intended load”¹⁸ for a roof:

The sweep would have no practical means of determining the maximum intended load for a roof, and no way of determining whether the roof was designed, constructed, and maintained to support the unknown maximum intended load. Only when a job would require a significant load on a roof or under other highly unusual circumstances would a sweep attempt to access the attic below a roof to check the structural integrity of the roof. We doubt most trades would be able to determine whether a roof could safely support its maximum intended load (as established by the builder and/or local code) (Ex. 150).

The final rule, like the construction fall protection standard, requires that employers are responsible for taking the steps necessary to ensure that each walking-working surface employee’s access has the strength and structural integrity to safely support the maximum intended load employers will place on

¹⁸NCSG is mistaken about the meaning and use of the term “maximum intended load.” The term refers to the maximum weight of “all employees, equipment, tools, materials, transmitted loads, and other loads” the employer reasonably anticipates putting on a walking-working surface, such as a roof. It does not mean the maximum weight building codes require or the builder designed and constructed a roof to tolerate, although the maximum intended load employers place on the surface must not exceed that maximum load limit for the surface.

the surface. NCSG agreed that assessing hazards and inspecting roof surfaces is necessary before workers step on roofs to perform chimney sweep work:

We recognize that the employer of a sweep must implement reasonable measures designed to determine whether a roof or other walking-working surface can be safely utilized by the employee to perform the pre-assigned task and any additional tasks that may be identified after the sweep arrives at the site (Ex. 150).

Where workers perform single-person jobs, which NCSG said are the majority of jobs their members perform, employers are responsible for ensuring that workers know how to assess and determine whether the walking-working surface they will access will support the loads reasonably anticipated to be placed on it. For example, employers must ensure that their employees (*e.g.*, chimney sweeps) know how to visually inspect or examine the roof for possible damage, decay, and other problems and look in attics to assess the strength and structural integrity of the roof. Employers also must ensure that workers actually do such visual assessments before they access a surface or perform a job. Finally, if there is a potential problem with the roof or if workers cannot determine whether the roof is safe for use, employers must ensure that workers know they must not step onto the roof. Although NCSG contends that it is infeasible for workers to determine if roof will support the loads they will place on it, their comments indicate that member companies and their workers already are doing this:

Once we actually get to the job, we are making a hazard assessment . . . of . . . electrical lines, the slope of the roof, the condition of the roof, is there adequate places for our ladders, can we safely access the roof with ladders, is the roof wet, ice covered, snow covered, and ultimately we use all of that information to formulate a go or no go roof decision, whether [we] are actually going to access the roof (Ex. 329 (1/18/2011, p. 276–303)).

In addition, NCSG said member employers also periodically go to jobs sites to discuss and observe workers performing tasks, further indicating that assessments and determinations of the strength and structural of roofs are being done (Ex. 150).

Finally, not only did NCSG say it is not feasible for its members to comply with final paragraph (b), they also said:

We doubt most trades would be able to determine whether a roof could safely support its maximum intended load (as established by the builder and/or local code) (Ex. 150).

Since 1994, the current construction fall protection standard has required employers performing construction activities to “determine if the walking-working surfaces on which its employees are to work have the strength and structural integrity to support employees safely” (§ 1926.501(a)(2)). According to NCSG, 20 percent of the work chimney sweep companies perform are significant and major installations and repairs and covered by the construction fall protection standard (Ex. 150). These operations involve a substantial quantity of equipment, tools and materials being used and placed on the roof. OSHA has not received any reports that chimney sweep companies have experienced difficulty assessing whether the roof has the “strength and structural integrity” to support workers and the equipment, materials, and tools they are using to make those installations and repairs. Because the final rule is consistent with the construction standard, OSHA believes NCSG members will not have difficulty visually assessing whether the roof can support chimney cleaning, inspections, and minor repair work, which do not require the quantities of equipment, tools, and materials of substantial and major installations/repair jobs. For these reasons, OSHA does not find NCSG’s infeasibility contention to be convincing.

Second, NCSG expressed concern that the final rule will require member companies to hire “a structural engineer or someone with significant advanced training” to make a “technical determination” that the walking-working surface has the necessary structural integrity, and that it would be infeasible for small companies to have a structural engineer or similar expert person on staff to assess the walking-working surfaces at each worksite (Ex. 150).

The final rule, like the construction fall protection standard, does not require that employers hire engineers or other experts to make a technical determination about whether a walking-working surface has the strength and structural integrity to support the maximum intended load employers reasonably anticipate placing on that surface. OSHA agrees with NCSG that employers may comply with final paragraph (b) by making “a visual examination of the condition of the roof and the rest of the structure” (Ex. 150). As OSHA discussed in the preamble to the proposed rule, if conditions warrant or if employers cannot confirm from the visual examination that the walking-working surface can support the load they will place on it, OSHA believes

employers need to conduct a more involved or detailed inspection to ensure the surface is safe for employees (75 FR 28888). OSHA does not believe NCSG members will have difficulty complying with this requirement. NCSG said member companies already conduct visual examinations and hazard assessments to determine whether roofs can support the total load their workers will place on them (Ex. 150). Moreover, NCSG said employers periodically come to job sites to observe how workers are performing tasks, which presumably include observing tasks such as hazard assessments and visual examinations of roofs.

Final paragraph (c)—Access and Egress

Final paragraph (c), like the proposal, requires that employers provide, and ensure that each worker uses, a safe means of access and egress to and from walking-working surfaces. For purposes of the final rule, the term “safe” means that no condition (for example, an obstruction, lock, damage) could prevent or endanger a worker trying to access or egress a walking-working surface. Thus, employers must ensure that means of access and egress remain clear and in good repair so workers can safely move about walking-working surfaces.

Final paragraph (c), like the proposal, replaces the specifications in the existing rule (§ 1910.22(b)) with performance-based language. The existing rule requires that aisles and passageways be kept in good repair, with no obstructions across or in aisles that could create a hazard. Where mechanical handling equipment is used, the existing rule requires that sufficient safe clearances be allowed for aisles, at loading docks, through doorways, and wherever turns or passage must be made. The revision ensures that final paragraph (c) applies to all walking-working surfaces the final rule covers, which means that employers must provide safe access to and egress from “any horizontal or vertical surface on or through which an employee walks, works, or gains access to a workplace location” (final § 1910.21(b)). Examples of walking-working surfaces that require safe access and egress include floors, stairways, ladders, roofs, ramps, and aisles. The final rule, by using the term “walking-working surface,” requires that employers ensure means of access and egress are safe regardless of whether the walking-working surfaces are on the same or different levels. The final rule also applies to both temporary and permanent walking-working surfaces.

OSHA notes that the final rule does not retain the specification language in

existing § 1910.22(b)(2) that requires appropriate marking of “permanent aisles and passageways.” The performance-based language in final paragraph (c) requires that an employer provide and ensure workers use a safe means of access and egress to and from walking-working surfaces. One way employers can meet the performance language is by appropriately marking passageways and permanent aisles as a means of identifying safe access and egress.

OSHA did not receive any comments on proposed paragraph (c) and finalizes the proposed provision, as discussed, with minor editorial changes for clarity.

Final paragraph (d)—Inspection, maintenance, and repair

Final paragraph (d), like the proposed rule, specifies general inspection, maintenance, and repair requirements for walking-working surfaces. Final paragraph (d)(1) requires that employers inspect and maintain walking-working surfaces in a safe condition. OSHA believes that inspecting walking-working surfaces is necessary to ensure they are maintained in a safe condition. To ensure they are in a safe condition, the final rule specifies that employers must inspect walking-working surfaces both (1) regularly and (2) as necessary.

The term “regular inspection” means that the employer has some type of schedule, formal or informal, for inspecting walking-working surfaces that is adequate enough to identify hazards and address them in a timely manner. The final rule uses a performance-based approach instead of mandating a specific frequency for regular inspections. OSHA believes that employers need to consider variables unique to each workplace that may affect the appropriate frequency for workplace inspections. Therefore, OSHA believes that employers are in the best position to evaluate those variables and determine what inspection frequency is adequate to identify and address hazards associated with walking-working surfaces. Once employers make that determination, the final rule requires that they conduct inspections of walking-working surface according to that frequency.

Adding a general requirement in the final rule for regular inspections of walking-working surfaces makes the rule consistent with OSHA’s construction standards. Section 1926.20(b)(2) requires employers to have a program that “provides for frequent and regular inspections of job sites, materials, and equipment.”

In addition to regular inspections, final paragraph (d)(1) also requires

employers to conduct inspections “as necessary.” For purposes of final paragraph (d)(1), inspecting workplaces “as necessary” means that employers must conduct inspections when particular workplace conditions, circumstances, or events occur that warrant an additional check of walking-working surfaces to ensure that they are safe for workers to use (*i.e.*, that the walking-working surface does not increase the risk of a slip, trip, or fall). For example, an additional inspection may be necessary to ensure that a significant leak or spill did not create a slip, trip, or fall hazard on walking-working surfaces. Similarly, employers may need to inspect outdoor workplaces after a major storm to ensure that walking-working surfaces are free from storm debris, downed power lines, and other related hazards.

The proposed rule specified that employers conduct “periodic” inspections, in addition to regular inspections. The purpose of the proposed requirement to conduct periodic inspections was to address specific workplace events, conditions, or situations that trigger slip, trip, or fall hazards not addressed by regular inspections, which are conducted at fixed times. However, OSHA believes that the language “as necessary” more accurately describes the purpose of the proposed requirement. Moreover, OSHA believes that the revised language clarifies when employers need to check walking-working surfaces and, thus, will enable employers to use their resources efficiently. Therefore, OSHA specified in final paragraph (d)(1) that employers must conduct inspections as necessary, in addition to regular inspections. Accordingly, employers must check the workplace when events, conditions, or situations arise that could put workers at risk of harm due to slips, trips, or falls, regardless of whether the workplace is due for a regular inspection. Thus, the final rule, as revised, fulfills the interpretation given to paragraph (d) in the proposal, that the employer “ensure that inspections are conducted frequently enough so that hazards are corrected in a timely manner” (75 FR 28862, 28875).

AFSCME recommended that § 1910.22 also require that employers perform a hazard assessment (Ex. 226). OSHA believes that requiring employers to inspect walking-working surfaces regularly and as necessary enables employers to determine the hazards that are present in those areas; therefore, additional language is not necessary.

NCSG objected to paragraph (d)(1)'s requirement that walking-working surfaces be maintained in a “safe”

condition as again incorporating the General Duty Clause (Ex. 150). That is not OSHA's intent, and the Agency incorporates its response to the that objection, discussed in final paragraph (a)(3), here. The same hazards are addressed by final paragraphs (a)(3) and (d)(1); (a)(3) requires that the surface be maintained free of those hazards, while (d)(1) requires inspection for and correction of those hazards when found.

Final paragraph (d)(2) requires that employers correct or repair hazardous conditions on walking-working surfaces before allowing workers to use those surfaces again. The final rule also requires that if employers cannot fix the hazard immediately, they must guard the hazard to prevent workers from using the walking-working surface until they correct or repair it. Taking immediate corrective action or guarding the hazard is important for the safety of workers; delaying either action can put workers at risk of injury or death. OSHA notes that corrective action may include removal of the hazard.

When employers cannot fix the hazard immediately and need to guard the hazard area, the final rule gives employers flexibility in selecting the type of guarding to use (*e.g.*, erecting barricades, demarcating no-entry zones). However, whatever method employers use, they must ensure it is effective in preventing workers from accessing or using the surface.

NCSG contended that proposed paragraph (d)(2) is a redundant provision, since proposed paragraph (a)(3) would already contain language requiring that walking-working surfaces be free of hazards (Ex. 150).

OSHA disagrees. First, as discussed, OSHA revised final paragraph (a)(3) so it more clearly identifies examples of walking-working surface hazards that could cause slips, trips, and falls. For example, if employers do not maintain walking-working surfaces free of leaks and spills, workers could slip and fall and be seriously injured. Corrosion can weaken walking-working surfaces and render them unable to support loads placed on them. In addition, examples of walking-working surface hazards incorporated in final paragraph (a)(3), stress that final § 1910.22, like the existing rule, covers more than slip, trip, or fall hazards.

Second, OSHA does not believe final paragraphs (a)(3) and (d)(2) are redundant because they serve different purposes and objectives. The purpose of final paragraph (a)(3) is to ensure employers have procedures or programs in place to maintain walking-working surfaces so workers are not exposed to hazards that may cause injuries such as

slips, trips, and falls. OSHA believes that if employers establish good housekeeping and maintenance procedures and programs they can prevent worker exposure to such hazards. However, even when employers establish rigorous housekeeping and maintenance programs, hazardous conditions may still arise. When they occur, final paragraph (d)(2) specifies what employers must do to correct or repair those hazards before they allow workers to use the surface.

Final paragraph (d)(3) requires that when any correction or repair involves the structural integrity of the walking-working surface, a qualified person must perform or supervise that correction or repair. For purposes of the final rule, OSHA defines a qualified person as “a person who, by possession of a recognized degree, certificate, or professional standing, or who by extensive knowledge, training, and experience has successfully demonstrated the ability to solve or resolve problems relating to the subject matter, the work, or the project” (see § 1910.21(b)). The definition in the final rule is the same as other OSHA standards (*e.g.*, §§ 1910.66, appendix C, Section I; 1910.269; 1915.35; 1926.32(l)).

Structural integrity generally addresses a structure's uncompromised ability to safely resist the loads placed on it. Deficiencies in the structural integrity of a walking-working surface can be extremely hazardous. OSHA believes corrections and repairs involving the structural integrity of a walking-working surface require the skill of a qualified person to ensure that affected surfaces are safe during and after repair or correction.

OSHA received three comments that raised concerns about the requirement in proposed paragraph (d)(3). Steven Smith of Verallia stated:

The duty to inspect, to guard, or take out of use certain areas, and to require ‘qualified persons’ be present for all repairs is duplicative of other OSHA requirements and adds additional layers of procedure and cost to employers that are unduly burdensome and unnecessary (Ex. 171).

Robert Miller of Ameren Corporation said:

Often times repairs to facility equipment is performed by contractors and their employees or supervisors would be considered qualified. As [paragraph (d)(3)] reads, this may be interpreted to mean that the employer is responsible to staff qualified employees for all structural repairs to walking and working surfaces. Clarity of expectations needs to be taken into consideration in the final version (Ex. 189).

Charles Lankford commented:

I believe it is excessive to ask of someone assigned to sand or scrape excessive rust off the metal treads of stairways and then paint them, to possess a degree or demonstrated 'extensive knowledge training, and experience' The more appropriate option here would be to require a qualified person for those applications where he/she is specifically required, and allow for a 'competent' person to apply his/her competency for the broad scope of tasks which he/she is well-suited to perform (Ex. 368).

OSHA believes the commenters have misinterpreted proposed paragraph (d)(3) as requiring qualified persons to conduct all correction and repair tasks. To the contrary, final paragraph (d)(3) is narrowly drawn. The final rule only requires that a qualified person perform or supervise the correction or repair of a walking-working surface if the correction or repair affects the structural integrity of the walking-working surface. If the correction or repair task does not rise to that level, the final rule does not require the employer to have a qualified person perform or supervise the task. Thus, using Mr. Lankford's example, final paragraph (d)(3) does not require employers to have a qualified person, as defined in this rule, perform or supervise sanding or scraping rust off of stairway treads. However, for example, a qualified person may have to perform or supervise welding a broken rung on a metal ladder.

To ensure that employers clearly understand the limited scope of final paragraph (d)(3), OSHA revised and reorganized the provision. For example, OSHA revised the language in the final rule to clarify that it only applies to repairs and corrections that affect the structural integrity of a walking-working surface, and not to the general maintenance of walking-working surfaces.

Mr. Smith generally commented that the requirements in proposed paragraph (d) were subjective and vague; however, he did not provide any explanation or examples to substantiate these comments (Ex. 171). OSHA disagrees with these comments. Pursuant to the OSH Act (29 U.S.C. 655(b)(5)), OSHA used performance-oriented language in paragraph (d) to provide employers with greater flexibility in complying with the requirements. As discussed above, OSHA also revised the language in paragraph (d) to provide greater clarity. In addition, this preamble explains in detail what employers must do to comply with the inspection, maintenance, and repair requirements in final paragraph (d).

Section 1910.23—Ladders

Final § 1910.23 revises and consolidates into one section the existing ladder requirements in §§ 1910.25 (Portable wooden ladders), 1910.26 (Portable metal ladders), 1910.27 (Fixed ladders), and 1910.29 (Mobile ladder stands and scaffolds (tower)). The final rule retains many of the existing requirements because OSHA believes they continue to provide an appropriate level of worker safety.

The final rule also updates and revises the existing OSHA general industry ladder rules to increase safety, clarity, consistency, and flexibility. To illustrate, the final rule revises the existing ladder requirements to make them consistent with OSHA's construction ladder standard (29 CFR 1926.1053). This action will make compliance easier for employers engaged in both general industry and construction operations.

Similarly, the final rule updates existing ladder requirements to make them consistent with current national consensus standards addressing ladders, including:

- American National Standards Institute (ANSI) A14.1–2007, American National Standard for Ladders—Wooden—Safety Requirements (A14.1–2007) (Ex. 376);
- ANSI A14.2–2007, American National Standard for Ladders—Portable Metal—Safety Requirements (A14.2–2007) (Ex. 377);
- ANSI A14.3–2008, American National Standard for Ladders—Fixed—Safety Requirements (A14.3–2008) (Ex. 378);
- ANSI A14.5–2007, American National Standard for Ladders—Portable Reinforced Plastic—Safety Requirements (A14.5–2007) (Ex. 391); and
- ANSI A14.7–2011, American National Standard for Mobile Ladder Stands and Mobile Ladder Stand Platforms (A14.7–2011) (Ex. 379).

Throughout the summary and explanation of final § 1910.23, OSHA identifies which provisions are consistent with these national consensus standards. OSHA believes this is important because national consensus standards represent accepted industry practices, and thus are technologically and economically feasible. Moreover, since most of those national consensus standards have been in place for years, OSHA believes that virtually all ladders this section covers that are manufactured today meet the requirements in those standards. As such, employers should not have problems complying with the

requirements in the final rule that OSHA drew from those standards.

OSHA notes that final § 1910.23 incorporates a number of revisions to make the final rule easier for employers and workers to understand and follow. First, as mentioned, OSHA has consolidated all of the general industry ladder provisions into this section. Second, within this section, OSHA has consolidated into a single paragraph the general requirements that are common to, and apply to, all types of ladders. These revisions eliminate unnecessary repetition, and make the section easier to follow. The organization of the consolidated final ladder requirements is:

- Paragraph (a) Application—This paragraph specifies the types of ladders the final rule covers or exempts;
- Paragraph (b) General requirements for all ladders—This paragraph specifies the requirements that are common to, and apply to, all types of ladders the final rule covers;
- Paragraph (c) Portable ladders—This paragraph specifies the requirements that apply to portable ladders, including wood, metal, and fiberglass or composite material portable ladders;
- Paragraph (d) Fixed ladders—This paragraph covers the provisions that apply to fixed ladders, including individual-rung ladders; and
- Paragraph (e) Mobile ladder stands and mobile ladder stand platforms—This paragraph updates existing OSHA requirements for mobile ladder stands, and adds requirements for mobile ladder stand platforms.

Third, in the final rule OSHA revises existing provisions to make them performance-based, whenever appropriate. Performance-based language gives employers maximum flexibility to comply with the requirements in the final rule by using the measures that best fit the individual workplace.

Finally, when possible, OSHA drafted final § 1910.23 in plain language, which also makes the final rule easier to understand than the existing rules. For example, the final rule uses the term "access" instead of "access and egress," which OSHA used in the existing and proposed rules. OSHA believes this revision makes the final rule easier to understand than the existing and proposed rules. Moreover, using "access" alone eliminates potential confusion since the term "egress" is often linked, and used interchangeably with, the term "means of egress," or "exit routes," which 29 CFR part 1910, subpart E (Exit Routes and Emergency Planning), addresses. The purpose of

that subpart is to establish requirements that provide workers with safe means of exit from workplaces, particularly in emergencies. That subpart does not address access to, and egress from, walking-working surfaces to perform normal and regular work operations. OSHA notes this rulemaking on walking-working surfaces does not affect subpart E.

OSHA believes the need for the vast majority of the provisions in final § 1910.23 is well settled. Pursuant to section 6(a) of the OSH Act (29 U.S.C. 655(a)), OSHA adopted most of them in 1971 from existing national consensus standards. Furthermore, all of the ANSI ladder standards, with the exception of A14.7–2011, Mobile Ladder Stands, derive from the original A14, American National Standard Safety Code for Construction, Care, and Use of Ladders, which ANSI first adopted in 1923. ANSI also revised and updated those standards regularly since then to incorporate generally accepted industry best practices.

With the revision of OSHA's ladder requirements for general industry, OSHA also revised the ladder requirements in other general industry standards. For example, OSHA replaced the ladder requirements in 29 CFR 1910.268 (Telecommunications) with the requirement that ladders used in telecommunications meet the requirements in 29 CFR part 1910, subpart D, including § 1910.23.

Paragraph (a)—Application

Final paragraph (a), similar to the proposal, requires that employers ensure that each ladder used in general industry, except those ladders the final rule specifically excepts, meets the requirements in final § 1910.23. Final paragraph (a) consolidates and replaces the application requirements in each of the existing OSHA ladder rules with a uniform application provision applicable to all ladders; § 1910.21(b) defines “ladder” as “a device with rungs, steps, or cleats used to gain access to a different elevation.”

Final paragraph (a) includes two exceptions. First, final paragraph (a)(1) specifies that § 1910.23 excepts ladders used in emergency operations such as firefighting, rescue, and tactical law enforcement operations or training for these operations. The proposed rule limited the exception to firefighting and rescue operations, but the final rule expanded that exception to cover all emergency operations and training, including tactical law enforcement operations. OSHA believes this exception is appropriate because of the exigent conditions under which

emergency responders perform those operations and training.

OSHA based the expansion of the exception for all emergency operations in part on comments from David Parker, manager of the risk-management section for the Pima County (Tucson, AZ) Sheriff's Office and Public Risk Management Association (PRIMA) board member, which represents 1,500 public-sector members, including the following comment:

[The impact of the proposed rulemaking on public entities] is particularly important in view of the fact that some of the requirements within the proposed [rule] may well be reasonable, necessary, cost effective and [technologically] feasible in common industrial environments. But they can create significant challenges and greater hazard when extended to certain public entity activities such as police tactical operations and training (Ex. 329, 01/20/2011, p. 7).

Mr. Parker also said that applying the ladder requirements to emergency operations, specifically law enforcement tactical situations, and their training exercises, was impractical because those operations require ladders designed for fast placement and access.

Second, final paragraph (a)(2), like the proposed rule, exempts ladders that are designed into or are an integral part of machines or equipment. OSHA notes this exemption applies to vehicles that the Department of Transportation (DOT) regulates (e.g., commercial motor vehicles). In particular, the Federal Motor Carrier Safety Administration (FMCSA) regulates the design of ladders on commercial motor vehicles. Section 4(b)(1) of the Occupational Safety and Health Act of 1970 (OSH Act) (29 U.S.C. 653(b)(1)) specifies that OSHA regulations do not apply where another Federal Agency “exercise[s] statutory authority to prescribe or enforce standards or regulations affecting occupational safety or health.”

Final paragraph (a)(2) is consistent with OSHA's ladder requirements for marine terminals (29 CFR 1917.118(a)(1)), which excepts ladders that are an integral part of transportation-carrier equipment (e.g., cargo containers, highway carriers, railway cars).

The exceptions in final paragraph (a) differ from the exceptions in the existing OSHA ladder rules (i.e., §§ 1910.25 (Portable wood ladders) and 1910.29 (Manually propelled mobile ladder stands and scaffold (towers))). Existing § 1910.25 notes that it does not specifically cover the following ladders: Other specialty ladders, fruitpicker's ladders, combination step and extension ladders, stockroom step ladders, aisleway step ladders, shelf ladders, and

library ladders. This final rule does not carry forward those exceptions. Thus, if an orchard ladder (formerly a fruitpicker's ladder) meets the definition of ladder in this final rule (i.e., “a device with rungs, steps, or cleats used to gain access to a different elevation”) and is used in general industry, the employer must ensure that it meets the requirements in the final rule. However, OSHA notes that the final rule does not apply to an orchard ladder used solely in agricultural activities covered by 29 CFR part 1928.

Existing § 1910.29(a) specifies that it does not cover “aerial ladders;” however, the existing rule does not define this term. Section 1910.67 (Vehicle-mounted elevating and rotating work platforms) defines “aerial ladder” as a “device consisting of a single- or multiple-section extension ladder” mounted on a vehicle (§ 1910.67(a)(2)). Although the final rule does not specifically except aerial ladders, OSHA believes that aerial ladders come within the exception for ladders designed into, or that are an integral part of, a machine or equipment, which includes vehicles.

OSHA did not receive any comments on paragraph (a) of the proposed rule and, therefore, adopted it as revised.

Paragraph (b)—General Requirements for All Ladders

Final paragraph (b), like the proposed rule, establishes general requirements that apply to all ladders this section covers, including wood, metal, and fiberglass or composite ladders, portable and fixed ladders, stepladders and stepstools, mobile ladder stands and mobile ladder stand platforms, and other ladders such as job-made ones. The final rule draws most of the provisions in this paragraph from the existing OSHA ladder standards for general industry and construction with the goal of making these standards consistent. OSHA also draws a number of provisions from the national consensus standards listed above.

Final paragraph (b)(1), like the proposed rule, requires that employers ensure ladder rungs, steps, and cleats are parallel, level, and uniformly spaced when the ladder is in position for use. The final provision is consistent with OSHA's other ladder requirements in general industry, marine terminals, longshoring, and construction (see §§ 1910.25(c)(2)(i)(B), 1910.27(b)(1)(ii), 1910.268(h)(2) and (6), 1917.118(d)(2)(i), 1917.119(b)(2), 1918.24(f)(2), 1926.1053(a)(2)). Final paragraph (b)(1) also is consistent with the ANSI ladder standards (A14.1–2007, Sections 6.2.1.2, 6.3.1.2, 6.4, and 6.5.4; A14.2–2007, Section 5.3; A14.3–2008, Sections 5.1.1,

and 5.1.3(e); and A14.7–2011, Section 4.3.3). As mentioned, OSHA believes the need for this ladder requirement is well settled. Most of OSHA's existing ladder requirements include this provision, as do all of the ANSI ladder standards.

Final paragraph (b)(1) adds the word "cleats," which is common terminology for a type of ladder cross-piece. OSHA added the term, which is interchangeable with "rungs" and "steps," to make final paragraph (b)(1) consistent with other Agency ladder standards and national consensus standards. OSHA did not receive any comments on the proposed provision.

Final paragraphs (b)(2) and (3) establish requirements for spacing between rungs, steps, and cleats on different types of ladders. With the exception of ladders in elevator shafts, the final rule requires that employers measure spacing between the centerlines (midpoint) of the rungs, steps, or cleats. Measuring the spacing at the centerline of the rung, step, or cleat ensures that measurements are done consistently throughout the length of the ladder and variations between different steps are minimal.

Like the proposed rule, final paragraph (b)(2) requires that, except for ladders in elevator shafts and telecommunication towers, employers ensure ladder rungs, steps, and cleats are spaced not less than 10 inches and not more than 14 inches apart. OSHA drew the proposed and final requirement from its construction ladder standard (§ 1926.1053(a)(3)(i)), which OSHA updated in 1990 (55 FR 47660 (11/14/1990)). Final paragraph (b)(2) is consistent with OSHA standards that have flexible vertical-spacing requirements. For example, OSHA's Telecommunications standard at 29 CFR 1910.268 specifies that vertical spacing on fixed ladders on communication towers not exceed 18 inches (§ 1910.268(h)(2)), and vertical spacing of rungs on climbing devices be not less than 12 inches and not more than 16 inches apart (§ 1910.268(h)(6)). In addition, three maritime standards specify that rungs be spaced between 9 to 16.5 inches apart (§§ 1917.118(d)(2)(1); 1917.119(b)(2); 1918.24(f)(2)).

Final paragraph (b)(2) provides greater flexibility than ANSI's ladder standards, most of which require that vertical spacing be 12 inches (A14.1–2007, Sections 6.2.1.2 and 6.3.1.2; A14.2–2007, Section 5.3; and A14.3–2008, Section 5.1.1), but the A14.7–2011 standard incorporates flexible vertical spacing on mobile ladder stands by

specifying that vertical spacing not exceed 10 inches (Section 4.3.3).

Although OSHA believes that both the final rule and existing OSHA and national consensus ladder standards provide adequate protection, the Agency also believes it is important that the final rule be consistent with the construction ladder requirements (§ 1926.1053). OSHA recognizes that some employers and workers perform both general industry and construction work. Increasing consistency between OSHA's general industry and construction standards will assist those employers and workers in complying with the OSHA requirements, and also will minimize the potential for confusion. In addition, providing greater flexibility will give employers more options to tailor ladders to specific work operations. There were no comments on the proposed provision.

The final rule, like the proposal, adds two exceptions to paragraph (b)(2). Final paragraph (b)(2)(i) specifies that employers must ensure rungs and steps on ladders in elevator shafts are spaced not less than 6 inches and not more than 16.5 inches apart, as measured along the ladder side rails.

Final paragraph (b)(2)(ii) specifies that employers ensure that vertical spacing on fixed ladder rungs and steps on telecommunication towers not exceed 18 inches, which is consistent with the existing requirement in OSHA's Telecommunications standard in § 1910.268(h)(2). Final paragraph (b)(2)(ii) also adds the phrase "measured between the centerlines of the rungs or steps." This addition clarifies the provision, and makes it consistent with final paragraphs (b)(2) and (3), which also requires vertical spacing to be measured between rung or step centerlines. OSHA did not receive any comments on the proposed exceptions.

Final paragraph (b)(3), like the proposed rule, addresses vertical spacing for stepstool steps. The final rule requires that employers ensure stepstool steps are spaced not less than 8 inches, and not more than 12 inches, apart, as measured between centerlines of the steps. The final paragraph (b)(3) deleted the terms "rungs" and "cleats" from the proposal because stepstools do not have them.

OSHA proposed requirements for stepstools in recognition that employers use stepstools routinely in general industry. However, stepstools differ from stepladders and other portable ladders, and OSHA does not believe that some of the requirements applicable to stepladders are appropriate for stepstools. The final rule defines a stepstool as a self-supporting, portable

ladder with flat steps and side rails that is designed so an employee can climb on all of the steps and the top cap. A stepstool is limited to those ladders that are not height adjustable, do not have a pail shelf, and do not exceed 32 inches (81 cm) in overall height to the top cap, except that side rails may continue above the top cap (§ 1910.21(b)).

Stepladders and other portable ladders, by contrast, do not have height limits, and the final rule requires that employers ensure workers do not stand on the top step or cap of those ladders.

OSHA drew final paragraph (b)(3) from its construction ladder standards (§ 1926.1053(a)(3)(ii)), and the final rule is consistent with the ANSI ladder standards that address stepstools (A14.1–2007, Section 6.5.4; and A14.2–2007, Section 6.6.4). These standards also address stepstools differently from step ladders and other portable ladders.

OSHA believes that employers should not have any difficulty complying with final paragraph (b)(3). The A14.1–2007 and A14.2–2007 standards have been available for years, so OSHA believes that almost all stepstools currently in use already meet the requirements in the final rule. OSHA did not receive any comments on proposed paragraph (b)(3).

Final paragraph (b)(4) consolidates OSHA's existing requirements on the minimum clear width for rungs, steps, and cleats on portable and fixed ladders (§§ 1910.25, 1910.26, 1910.27). The final rule requires employers to ensure that ladder rungs, steps, and cleats on portable and fixed ladders have a minimum "clear width" of 11.5 inches and 16 inches, respectively. "Clear width" is the space between ladder side rails, but does not include the width of the side rail. OSHA also incorporates as paragraph (b)(4) the proposed note informing employers that the clear width measurement on fixed ladders is done before installation of any ladder safety system.

Generally, the final rule is consistent with OSHA's existing ladder standards, notably OSHA's standards for portable wood ladders, fixed ladders, mobile ladder stands and platforms, and construction ladders (existing §§ 1910.25(c)(2)(i)(c)); 1910.27(b)(1)(iii); 1910.29; and current § 1926.1053(a)(4)). The final rule differs slightly from the existing rule for portable metal ladders, which required a minimum clear width of 12 inches (§ 1910.26(a)(2)(i)). However, the final rule will not require employers to take any action since the existing portable metal ladder rules already meet the minimum 11.5-inch clear-width requirement of the final rule. In addition, OSHA removed the term "individual-rung ladder" from

final paragraph (b)(4) because these ladders are a type of fixed ladder and, therefore, do not need a separate listing.

The final rule also is consistent with the ANSI ladder standards (A14.1–2007, Sections 6.2.1.3, 6.3.2.4, 6.3.3.8, 6.3.4.3, 6.3.5.4, and 6.4.1.3; A14.2–2007, Sections 6.1.3, 6.2.1, and 6.2.2; and A14.3–2008, Section 5.1.2). Although the minimum clear widths in the ANSI standards differ depending on the type of portable or fixed ladder used, virtually all of these standards require the minimum clear width specified by the final rule.

Final paragraph (b)(4) contains four exceptions to the minimum clear-width requirement. First, final paragraph (b)(4)(i), like the proposal, includes an exception for ladders with narrow rungs that are not designed to be stepped on, such as those located on the tapered end of orchard ladders and similar ladders. This exception recognizes that manufacturers did not design the narrow rungs at the tapered end of the ladder to be foot holds, but rather designed them to allow the worker to establish the best work position. For example, tapered ladders allow workers to safely position the ladder for activities such as pruning tree branches. Since workers will not use the narrow rungs on the tapered end of orchard and other similar ladders for stepping, OSHA believes that it is not necessary to apply the clear width requirements in the final rule to the narrow rungs on these ladders. However, OSHA stresses that the exception only applies to the narrow rungs on the tapered end; the remainder of the ladder rungs where workers may step must meet the requirements in the final rule. Moreover, employers are responsible for ensuring that workers do not step on the narrow rungs.

Second, final paragraph (b)(4)(ii) retains the proposed rule's exception for portable manhole entry ladders supported by manhole openings. The final rule only requires that the rungs and steps of those ladders have a minimum clear width of 9 inches. Southern New England Telephone Co. said the revision was necessary because the ladder supported at the manhole opening reduces clearance for workers climbing through the manhole opening (Ex. OSHA–S041–2006–0666–0785). The commenter also said that using a narrower ladder provides more space for workers to negotiate the manhole opening, which makes it less likely that space restrictions could cause the worker to fall.

Third, final paragraph (b)(4)(iii), like the proposal, incorporates the exception in OSHA's Telecommunications rule

(§ 1910.268(h)(5)) for rolling ladders used in telecommunications centers. That standard only requires that rungs and steps on rolling ladders used in telecommunication centers have a minimum clear width of 8 inches. OSHA notes that the final rule deletes the existing requirements in § 1910.268(h), and specifies that ladders used in telecommunications must meet the requirements in revised subpart D.

Final paragraph (b)(4)(iv) is a new requirement that addresses the minimum clear width for stepstools, which OSHA defines as a type of portable ladder (§ 1910.21(b)). The final rule specifies that stepstools must have a minimum clear width of at least 10.5 inches instead of the 11.5-inch minimum clear width that the final rule requires for other portable ladders. Although OSHA did not receive any comments on this issue, in accordance with section 6(b)(8) of the OSH Act (29 U.S.C. 655(b)(8)), the Agency added this provision to make the rule consistent with ANSI/ALI national consensus standards for wood and metal portable ladders (A14.1–2007 and A14.2–2007).

As mentioned above, final paragraph (b)(4) incorporates into this provision the language from a note in the proposal specifying the minimum clear width on fixed ladders is to be measured before installing ladder safety systems. OSHA included the information to help employers understand how OSHA measures clear width on fixed ladders for compliance purposes and has determined that the information may better serve employers in the actual provision, instead of in a note. OSHA did not receive any comments on the proposed provision.

Final paragraph (b)(5), like the proposal, adds a new requirement that employers ensure wooden ladders are not coated with any material that may obscure structural defects. Such defects, if hidden by coating or paint, could injure or kill workers if the defected ladder they step on breaks or collapses. OSHA drew the final rule from its construction ladder standard, which prohibits coating wood ladders with any "opaque covering" (§ 1926.1053(a)(12)), but adds language identifying the hazard that the provision will prevent (*i.e.*, workers using defective ladders with obscured "structural defects"). The final rule is consistent with A14.1–2007, which specifies that wood ladders may have transparent, non-conductive finishes (*e.g.*, shellac, varnish, clear preservative) but not with opaque finishes (see A14.1–2007, Section 8.4.6.3). The A14.3–2008 standard includes the same requirement for fixed wood ladders (Section 9.3.8). OSHA

believes that A14.1–2007 and A14.3–2008 provide helpful examples of the types of coatings that the final rule prohibits. OSHA did not receive any comments on the proposed provision.

Final paragraph (b)(5) does not carry forward the language in the construction and ANSI ladder standards that allows identification or warning labels to be placed on one face of the side rails. OSHA does not believe the language is necessary for two reasons. First, for purposes of final paragraph (b)(5), OSHA does not consider manufacturer-applied warning and information labels to be "coatings," therefore, final paragraph (b)(5) does not prohibit placing labels on one side of side rails. Second, OSHA believes that the requirements in final paragraph (b)(9) to inspect ladders before initial use each workshift to identify defects, and the requirement in final paragraph (b)(10) to remove defective ladders from service, will ensure that employers do not use ladders with structural defects, even structural defects covered up by labels placed on the face of side rails. OSHA did not receive any comments on the proposed provision.

Final paragraph (b)(6) requires that employers ensure metal ladders are made with corrosion-resistant material or are protected against corrosion. For example, metal ladders coated or treated with material that resists corrosion will meet this requirement. Alternatively, employers may use metal ladders made with material that is inherently corrosion-resistant, such as aluminum. OSHA believes this provision is necessary to protect workers because rusty metal ladders can become weak or fragile, and can break when a worker steps on them. To illustrate, untreated metal ladders exposed to certain acids may experience chemical corrosion that could reduce the strength of the metal.

Final paragraph (b)(6) carries forward the language in OSHA's existing portable metal ladders standard (§ 1910.26(a)(1)), and is consistent with a similar provision in the existing fixed ladder standard (§ 1910.27(b)(7)(i)). The final rule also retains the language in the existing rule that employers do not have to protect metal ladders that are inherently corrosion resistant. In the proposed rule, OSHA preliminarily determined that this language was not necessary because ladders "protected against corrosion" included ladders made of inherently corrosion-resistant material. However, upon further analysis, OSHA believes that retaining the existing language (§ 1910.26(a)(i)) makes the final rule clearer and better reflects the purpose of this provision.

OSHA did not receive any comments on the proposed provision.

Final paragraph (b)(7), like the proposed rule, specifies that employers must ensure ladder surfaces are free of puncture and laceration hazards. Workers can suffer cuts and puncture wounds if a ladder has sharp edges or projections, splinters, or burrs. The final rule consolidates and simplifies OSHA's existing ladder requirements addressing puncture and laceration hazards (see §§ 1910.25(b)(1)(i) and (c)(2)(i)(f); 1910.26(a)(1) and (a)(3)(viii); and 1910.27(b)(1)(iv) and (b)(2)). Although final § 1910.22(a)(3) contains a similar general requirement, OSHA believes it is important to include language in final paragraph (b)(7) to emphasize the need to keep ladders free of such hazards to prevent injuries and falls. For example, a worker's instantaneous reaction to getting cut on a sharp projection could be to release his or her grip on the ladder, which could cause the worker to fall. OSHA did not receive any comments on the proposed provision.

Final paragraph (b)(8), like the proposed rule, requires that employers ensure ladders are used only for the purposes for which they were designed. OSHA believes, as the ANSI standards states, that “[p]roper use of [ladders] will contribute significantly to safety” (A14.1–2007, Section 8.1.5; A14.2–2007, Section 8.1.5; and A14.3–2008, Section 9.1.2). Improper use of a ladder can cause workers to fall.

Final paragraph (b)(8) revises the existing general industry ladder rules. Using performance-based language, final paragraph (b)(8) consolidates the existing general industry requirements on permitted and prohibited uses of ladders (§§ 1910.25(d)(2) and 1910.26(c)(3)(vii)). Those standards specify a number of uses that are clearly unsafe and, thus, prohibited, such as using ladders for scaffold planks, platforms, gangways, material hoists, braces, or gin poles. However, the existing rules do not, and could not, provide an exhaustive list of all unsafe uses. For example, the existing rules do not specifically prohibit self-supporting portable metal ladders to be used as a scaffold plank support system, yet such practices are clearly dangerous and an improper use of ladders. Therefore, final paragraph (b)(8) revises the existing rules to specify how employers must use ladders, instead of specifying a longer, but still incomplete, list of prohibitions. OSHA's approach to final paragraph (b)(8) is consistent with A14.3–2008, which states, “The guidelines discussed in this section do not constitute every proper or improper procedure for the maintenance and use

of ladders (Section 9.1.1.)” Accordingly, the prohibited uses listed in the existing rules continue to be improper procedures for the use of ladders, which this final rule continues to prohibit.

Final paragraph (b)(8) is virtually identical to OSHA's construction ladder standard (§ 1926.1053(b)(4)), and is consistent with the ANSI ladder standards (A14.1–2007, Section 8.3; A14.2–2007, Section 8.3; and A14.3–2008, Section 9.1.2). Final paragraph (b)(8) does not carry forward the language in existing § 1910.26(c)(3)(vii), which prohibits employers from using ladders for certain purposes “unless specifically recommended for use by the manufacturer.” OSHA believes that requiring employers to use ladders “only for the purposes for which they were *designed* [emphasis added]” achieves the same purpose. In addition, the revised language in the final rule ensures that the revised requirement also covers job-made ladders the employer designs. OSHA did not receive any comments on the proposed provision.

Final paragraph (b)(9) requires that employers ensure ladders are inspected before initial use in each work shift, as well as more frequently as necessary. The purpose of this inspection is to identify visible defects that could affect the safe use and condition of the ladder and remove unsafe and damaged ladders from service before a worker is hurt. Employers may accomplish the visual inspection as part of the worker's regular procedures at the start of the work shift. The final rule differs in two respects from the existing and proposed standards. First, the final rule states more explicitly than the existing and proposed rules when the inspection of each ladder must be done: before using the ladder for the first time in a work shift. Two of OSHA's existing general industry rules require that employers inspect ladders “frequently” and “regularly” (§§ 1910.25(d)(1)(x) and 1910.27(f)). OSHA's construction ladder standard requires employers to inspect ladders “on a periodic basis” (§ 1926.1053(b)(15)).

In the proposed rule, OSHA sought to clarify the frequency of ladder inspections. OSHA drew on the language in its longshoring ladder standard (§ 1918.24(i)(2)) and A14.1–2007 and A14.2–2007. OSHA's longshoring standard requires that employers inspect ladders “before each day's use” (§ 1918.24(i)(2)), and the ANSI standards require that employers inspect ladders periodically, “preferably before each use” (A14.1–2007, Section 8.4.1.; and A14.2–2007, Section 8.4.1).

Based on those standards, OSHA proposed that employers inspect ladders “before use.” OSHA intended the proposed language to mean that employers must ensure ladders are inspected before workers use them for the first time during a work shift. OSHA believes the language in final paragraph (b)(9) more clearly and directly states the Agency's intention.

Second, final paragraph (b)(9) adds language specifying that, in addition to inspecting ladders before they are used for the first time during the work shift, employers also must inspect ladders “as necessary” to identify defects or damage that may occur during a work shift after the initial check. OSHA believes that situations may arise or occur during a work shift that necessitate employers conducting additional inspections of ladders to ensure that they continue to remain safe for workers to use. For example, if a ladder tips over, falls off a structure (e.g., roof) or vehicle, is struck by an object (e.g., vehicle or machine), or used in a corrosive environment, it needs to be inspected to ensure damage has not occurred and the ladder is still safe to use. The final rule is consistent with the existing requirement for portable metal ladders § 1910.26(c)(2)(vi), which specifies that employers must inspect ladders “immediately” if they tip over or are exposed to oil or grease. Similarly, OSHA's marine terminal and longshoring standards require that employers inspect ladders “after any occurrence, such as a fall, which could damage the ladder” (29 CFR 1917.119(e)(2) and 1918.24(i)(2)). OSHA believes the addition to final paragraph (b)(9) will help employers implement a proactive approach that ensures ladders are safe at the start of, and throughout, each work shift. The final rule better articulates OSHA's intent in the proposal for the frequency of inspections. (See 75 FR 28876, noting that workers need not inspect ladders multiple times per shift “unless there is a reason to believe the ladder has been damaged due to an event such as being dropped.”)

Final paragraph (b)(9) provides employers with flexibility to tailor ladder inspections to the situations requiring them. For example, inspections conducted at the start of the work shift may include checking the ladder to ensure the footing is firm and stable, engaging spreader or locking devices to see if they work, and identifying whether there are missing or damaged components. If a ladder tips over, the employer may focus the inspection on identifying whether footing problems may have caused the

tip-over or examining whether rungs are still firmly attached. On the other hand, the existing rule does not provide this flexibility and requires that all inspections conducted after a tip over must include the following:

- Side rails for dents or bends;
- Rungs for excessive dents;
- All rung-to-side-rail connections;
- Hardware connections; and
- Rivets for shear (existing

§ 1910.26(c)(2)(vi)(a)).

OSHA believes this list of inspection procedures may be both over-inclusive and under-inclusive. For example, the existing rule does not specify that the inspection cover the ladder footing. OSHA believes that using performance-based language will allow employers to determine the scope of the inspection that may be necessary.

Finally, OSHA notes that the revisions simplifying final paragraphs (b)(8) and (9) are consistent with the goals of the Plain Language Act of 2010. OSHA did not receive any comments on these proposed provisions.

Final paragraph (b)(10), which is almost identical to the proposed rule, requires that employers immediately tag ladders with structural or other defects “Dangerous: Do Not Use” or similar language that is in accordance with § 1910.145. In addition, final paragraph (b)(10) requires that employers remove defective ladders from service until the employer repairs them in accordance with § 1910.22(d) or replaces them. Final § 1910.22(d)(2) contains a general requirement that employers correct, repair, or guard against “hazardous conditions on walking-working surface surfaces,” including ladders. However, OSHA believes it is important to also include a specific requirement in this section because falling from a defective ladder could seriously injure or kill workers. Final paragraph (b)(10) clearly instructs employers of the minimum procedures (*i.e.*, tagging, removing, and repairing or replacing) that they must take when an inspection reveals a ladder to be defective. Final paragraph (b)(10), like final § 1910.22(d)(2), is a companion, and logical extension, to the requirements that employers maintain walking-working surfaces, including ladders, in a safe and serviceable condition, and inspect them as required (§§ 1910.22(d)(1); 1910.23(b)(9)).

Final paragraph (b)(10) is a performance-based consolidation of the existing general industry, maritime, and construction requirements (§§ 1910.25(d)(1)(iii), (d)(1)(x), and (d)(2)(viii); 1910.26(c)(2)(vii); 1915.72(a)(1); 1917.119(e)(1); 1918.24(i)(1); and 1926.1053(b)(16)). Some of these standards are similar to

the final rule, while other standards specify particular ladder defects that necessitate removing the ladder from service. For example, the construction ladder standard requires removal of ladders that have defects such as broken or missing rungs, cleats, or steps; broken rails; or corroded ladder components (§ 1926.1053(b)(16)), and the existing general industry portable wood ladders standard requires employers to replace frayed rope (§ 1910.25(d)(i)(iii)). The final rule simplifies the existing requirements by specifying that employers remove ladders that have “structural or other defects.” OSHA believes this approach will make the final rule easier to understand. As noted above, the defects listed in the existing rules in §§ 1910.25(d)(2)(viii) and 1910.26(c)(2)(vii) continue to warrant removal of the ladder from service.

Final paragraph (b)(10) retains the key signal warning word “Dangerous” in existing § 1910.25(d)(1)(x). OSHA proposed to remove the word from the regulatory text and include it in guidance material. After further analysis, OSHA believes that retaining the signal word is necessary to get workers’ attention to provide them with basic information that a hazard exists and they must not use the ladder. OSHA did not receive any comments on proposed paragraph (b)(10).

Final paragraphs (b)(11), (12), and (13), like the proposed rule, are companion provisions that establish safe work practices for climbing ladders. The final paragraphs are almost identical to OSHA’s construction ladder standard (*see* § 1926.1053(b)(20), (21), and (22)). OSHA notes that final paragraphs (b)(11), (12), and (13) apply to all ladders this section covers, including mobile ladder stands and mobile ladder stand platforms.

Final paragraph (b)(11), like the existing (§ 1910.26(c)(3)(v)) and proposed rules, requires that employers ensure workers face the ladder when climbing up and down it. The final rule also is almost identical to OSHA’s construction ladder standard (§ 1926.1053(b)(20)) and the ANSI ladder standards (A14.1–2007, Section 8.3.7; A14.2–2007, Section 8.3.7; and A14.3–2008, Section 9.2.1). Facing the ladder while climbing ensures that workers are able to maintain a firm grip on the ladder and also identify possible defects before climbing any higher. Accordingly, workers are to face the steps, not away from them, when climbing up and down mobile units.

To make final paragraph (b)(11) easier to understand, OSHA replaced the existing and proposed language “ascending or descending” with plain

language: Climbing up and down. This revision is consistent with general comments recommending that OSHA make the final rule easier to read and understand (Exs. 53; 175). OSHA did not receive any comments on the proposed provision.

Final paragraph (b)(12), like the proposed rule, adds a new provision requiring that employers ensure workers use “at least one hand to grasp the ladder at all times when climbing up and down it.”¹⁹ As stated in the proposal, the intent of this provision is for employers to ensure their workers maintain “three-point contact” (*i.e.*, three points of control) with the ladder at all times while climbing. The A14.3–2008 standard requires three-point contact and defines the term as consisting of “two feet and one hand or two hands and one foot which is safely supporting users weight when ascending/descending a ladder” (Section 9.2.1). OSHA drew final paragraph (b)(12) from its construction ladder standard (§ 1926.1053(b)(21)). The final provision also is consistent with ANSI ladder standards.

The final rule requires that employees “grasp” the ladder with at least one hand when climbing, which is equivalent to the requirement in A14.1–2007 and A14.2–2007 to “maintain a firm hold on the ladder” (A14.1–2007, Section 8.3.7.; A14.2–2007, Section 8.3.7). At the hearing, Ellis explained the importance of maintaining a firm grasp on the ladder at all times, “[F]alls happen very suddenly and unless you have your hand on something or your foot on something that’s horizontal and flat or round * * * you’re going to be surprised. And once you get to a few inches away the speed of the fall is such you can’t reach—you can’t grab, that’s why you can’t stop a fall” (Ex. 329 (1/21/2011), p.277). Many stakeholders said employers already train workers to use three-point contact when climbing ladders (*e.g.*, Exs. 148; 158; 181).

NCSG contended that an employer can comply with this requirement if its employees slide one hand along the rail of the ladder while climbing so that the other hand is free to carry an object (Ex. 150). It claimed that merely maintaining “contact” between the hand and the ladder at all times was sufficient (*see* Ex. 329 (1/18/2011), p. 289). OSHA does not agree that this technique is grasping the ladder within the meaning of paragraph (b)(12). It is important that a climber have a firm hold on the ladder

¹⁹OSHA notes paragraph (b)(12) pertains only to the process of climbing up and down the ladder, not working on the ladder once the worker reaches the correct level.

with at least one hand to help ensure that the climber maintains his or her balance. Moreover, as Ellis noted, when a climber starts to lose balance, the climber needs “the grip available to stabilize the body” (Ex. 329 (1/21/2011), p. 275–76). OSHA notes that it rejected NCSG’s “sliding hand” technique as unsafe when it adopted the construction standard; in fact, the construction standard uses the term “grasp” precisely because OSHA intended to forbid the practice (55 FR 47682).

OSHA notes that the requirement that a worker maintain a firm grasp of the ladder with at least one hand at all times while climbing does not prohibit workers from carrying certain objects while they climb. However, any object a worker does carry must be of a size and shape that still allows the worker to firmly grasp the ladder with that hand while climbing.

OSHA received one comment on proposed paragraph (b)(12). Ellis Fall Safety Solutions (Ex. 344) recommended OSHA require that workers hold onto horizontal rungs and not side rails or ladder extensions. Ellis submitted a study showing that climbers cannot hold onto side rails or ladder extensions effectively if they begin to fall off the ladder. OSHA agrees with Ellis that grasping the ladder on horizontal rungs is preferable and encourages employers to follow this practice. However, OSHA also recognizes there may be times when it is necessary for employees to hold the side rails. OSHA is not aware of any reports that holding the side rails of ladders creates a problem when workers maintain three points of contact while climbing. In addition, OSHA notes that neither the construction ladder standard (§ 1926.1053(b)(21)) nor the ANSI/ALI consensus standards (A14.1–2007 and A14.2–2007) prohibit workers from holding onto ladder side rails while climbing.

Final paragraph (b)(13), like the proposed and construction ladder rules (§ 1926.1053(b)(22)), requires that employers ensure workers climbing ladders do not carry any objects or loads that could cause them to lose their balance and fall. As OSHA stated in the preamble to the construction ladder standard, the purpose of this provision is to emphasize the importance of proper and careful use of ladders when workers need to carry items to and from work spaces:

It is OSHA’s belief that the employee’s focus and attention while climbing up and/or down a ladder should be on making a safe ascent or descent and not on transporting items up and down the ladder (55 FR 47682).

As explained above, neither the final rule nor the construction ladder standard prohibit workers from carrying an object while climbing a ladder. The final rule allows workers to carry an object, provided they:

- Face the ladder while climbing (final paragraph (b)(11));
- Grasp the ladder with at least one hand at all times when climbing up and down the ladder, which will ensure workers maintain at least three points of contact (final paragraph (b)(12)); and
- Do not carry an object(s) that could cause them to lose their balance and fall (final paragraph (b)(13)).

Similarly, in the preamble to the construction ladder standard, OSHA said:

Although OSHA believes that small items such as hammers, pliers, measuring tapes, nails, paint brushes, and similar items should be carried in pouches, holsters, or belt loops, the language in the final rule would not preclude an employee from carrying such items while climbing a ladder so long as the items don’t impede the employee’s ability to maintain full control while climbing or descending the ladder (55 FR 47682).

Under both the final and construction rules, employers are responsible for ensuring that workers are able to maintain full control and balance while they are climbing. Employers also must ensure that carrying an object does not impede workers’ control and balance, such as struggling to maintain their control or balance on the ladder. To that end, employers need to evaluate whether the weight and size of tools and other items workers use for jobs are such that workers can maintain their balance and grasp on the ladder while carrying the item in that hand or whether workers need to use other methods to get the items to the roof safely, such as using backpacks, making multiple climbs, or lifting items attached to ropes. NCSG said their members conduct evaluations (*i.e.*, hazard assessments) at each job site, which include whether workers “can . . . safely access the roof with ladders” (Ex. 329 (1/18/2011), p. 276).

Employers also need to ensure workers know what items they can and cannot carry while climbing ladders. NCSG agreed, saying they train workers so they “understand what items they are permitted to carry and how they should be carried so that they maintain a stable position while ascending and descending the ladder(s)” (Ex. 150). For example, OSHA does not believe workers can maintain the required balance and control if they must carry a heavy or bulky object in one hand while climbing.

NCSG raised several objections to proposed paragraphs (b)(12) and (13). NCSG said the requirements “would make it technically and economically infeasible for [chimney] sweeps to perform their work” because it would be impossible for workers to get items up to the roof if they cannot carry them in one hand and slide their other hand up the ladder rail while climbing (Ex. 150). OSHA does not believe the record supports NCSG’s infeasibility contentions.

First, as stated above, final paragraphs (b)(12) and (13) do not prohibit workers from carrying an item when they climb a ladder. Workers can carry an object while climbing a ladder, provided they also can grasp the ladder with that hand during the climb. Some of the objects NCSG said their members carry are small enough that it would be possible for workers to hold them and grasp the ladder with the same hand.

Second, even if a worker cannot carry a particular object and still maintain a firm grasp on the ladder with that hand, there are a variety of other methods they can use to transport the object(s) to the roof and still allow the worker to firmly grasp the ladder with their hands. According to NCSG, member companies already use them. For example, NCSG said workers get tools and equipment, such as flashlights, mirrors, screwdrivers, wrenches, cameras, tape measures, and cleaning rods and brushes, up to the roof using backpacks, tool belts, and quivers (Ex. 150). For one story homes, NCSG said workers lean roof hook ladders against the eaves and pull the ladder up once they have climbed up on the roof (Ex. 329 (1/18/2011), p. 342).

If the job is a major repair (*e.g.*, relining or rebuilding chimneys), which according to NCSG accounts for 20 to 25 percent of chimney sweep work, employers use scaffolds or aerial lifts (Ex. 329 (1/18/2011), p. 327). According to NCSG, not only do scaffolds allow employers to get materials to the roof without carrying them on a portable ladder, they provide workers with “a nice flat platform to stand on” (Ex. 329 (1/18/2011), p. 325).

OSHA believes that chimney sweep companies also can use handlines and ropes to pull heavy or bulky items up on the roof. OSHA believes this method will work particularly well for getting chimney caps and roof hook ladders to the roof, both of which NCSG said do not fit into backpacks. Pulling up materials to the roof is a common practice in the construction industry. In the preamble to the construction ladder standard, OSHA said workers take “large or heavy” items to the roof by

“pull[ing] the object up or lower[ing] it with a handline” (55 FR 47682). NCSG, however, said that “it is unlikely [lifting items to the roof with a handline] can be done without risking damage to the home or [item].” NCSG did not explain or provide any evidence to support their claim. In addition, NCSG did not provide any evidence that it is not possible to prevent damage by using appropriate techniques or padding. OSHA has not received any reports and is not aware of any problems in the construction industry using handlines to pull up items to residential or commercial roofs.

NCSG claimed that using handlines to lift items to roofs would be “economically infeasible” because it could not be done without the assistance of a second person, which they claim would increase job costs by about 30 percent. OSHA finds this claim unsupported by the record. NCSG did not explain or provide evidence about why a second worker would be necessary in such instances. In addition, NCSG did not provide any support for its claim that costs would increase by 30 percent.

Finally, NCSG contended that complying with final paragraphs (b)(12) and (13) would create a greater hazard for workers than allowing them to carry objects up ladders with one hand while sliding the other hand up the ladder rails (Ex. 150). In particular, they said that attaching work tools and other items to a rope and lifting them to the roof would create a greater fall hazard because workers must be “right at the roof’s edge to keep the item in view and lift it onto the roof” (Ex. 150). To establish that an OSHA standard creates a greater hazard an employer must prove, among other things, that the hazards of complying with the standard are greater than those of not complying, and alternative means of employee protection are not available (*Bancker Construction Corp., v. Reich*, 31 F.2d 32, 34 (2d Cir. 1994); *Dole v. Williams Enterprises, Inc.*, 876 F.2d 186, 188 (D.C. Cir. 1989)).

NCSG has not provided any evidence to establish that complying with final paragraphs (b)(12) and (13) or using other methods to get objects up to the roof is more dangerous than allowing employees to carry objects, regardless of their weight and size, in one hand while sliding the other hand up ladder rails while they climb the ladders. In fact, an NCSG witness testified that the greatest fall hazard is the “ladder-to-roof transition” (Ex. 329 (1/18/2011), p. 333). The transition is made even more hazardous if workers are carrying heavy or bulky objects in one hand and trying

to get onto the roof by sliding the other hand along the ladder rail.

NCSG also maintained that pulling items up to the roof with handlines would require workers to be at the roof’s edge, where they will be at risk of falling. NCSG did not provide any evidence to support that claim. OSHA notes that the final rule requires workers to use fall protection while working at the edge of a roof.

Finally, although NCSG said they were “not aware of any feasible alternatives to carrying items in one hand and sliding the other hand up the ladder rail, NCSG identified several alternatives that they currently are using. NCSG said workers put tools and other items in backpacks, tool belts, and quivers so they can climb ladders with both hands free, instead of carrying the objects in their hands (Ex. 150). With the exception of roof hook ladders and chimney caps, NCSG said they are able to get all items up to the roof in backpacks, tool belts, and quivers. OSHA also believes that handlines and ropes are feasible to safely lift chimney caps and roof hook ladders.

Paragraph (c)—Portable Ladders

Final paragraph (c), like the proposed rule, sets forth requirements for portable ladders. The requirements in final paragraph (c) are in addition to the requirements in final paragraph (b) that apply to all ladders this section covers. The final rule defines “portable ladder” as a ladder that can be readily moved or carried, and usually consists of side rails joined at intervals by steps, rungs, or cleats (§ 1910.21(b)).

To further OSHA’s goal of making the final rule clearer and easier to read, final paragraph (c) replaces existing detailed design and construction specifications with more flexible performance-based language. By doing so, OSHA was able to make other revisions that will increase employers’ and workers’ understanding of the final rule. First, using performance-based language allowed OSHA to combine the existing requirements for portable wood (existing § 1910.25) and portable metal ladders (existing § 1910.26), thereby eliminating unnecessary repetition. Second, it allowed OSHA to remove the exceptions in existing § 1910.25(a) for “special” types of ladders, including orchard ladders, stock room step ladders, and library ladders. Final paragraph (c) covers all of those ladders to the extent that employers use them in general industry operations. Finally, it also allows OSHA to remove the separate requirements for certain types of portable ladders such as painter’s

stepladders, mason’s ladders, and trolley and side-rolling ladders.

Final paragraph (c)(1), like the existing and proposed rules, requires that employers minimize slipping hazards on portable metal ladders. Accordingly, the final rule specifies that employers must ensure rungs and steps of portable metal ladders are corrugated, knurled, dimpled, coated with skid-resistant material, or otherwise treated to minimize the possibility of slipping. Final paragraph (c)(1) is the same as OSHA’s construction ladder standard (§ 1926.1053(a)(6)(ii)), and is consistent with A14.2–2007 (Section 5.5). Ellis (Ex. 155) supported skid-resistance on ladder steps. There were no opposing comments on the provision.

Final paragraph (c)(2), like the proposal, retains existing requirements (§§ 1910.25(c)(2)(i)(f) and 1910.26(a)(3)(viii)) that employers ensure each stepladder, or combination ladder used in a stepladder mode, is equipped with a metal spreader or locking device. The final rule also requires that the spreader or locking device securely holds the front and back sections of the ladder in an open position while the ladder is in use. The term “stepladder mode” as used in final paragraph (c)(2) means that the configuration of the combination ladder is such that the ladder is self-supporting and functions as stepladder.

The OSHA construction ladder standard also requires that stepladders have spreaders or locking devices (§ 1926.1053(a)(8)). In addition, the A14.1–2007 and A14.2–2007 standards require spreaders or locking devices for stepladders, and A14.2–2007 requires that combination ladders and trestle ladders also have those devices (A14.1–2007, Section 6.2.1.6; and A14.2–2007, Sections 6.1.9, 6.5.8, 6.6.8). The proposed rule would have required that stepladders be “designed” with spreaders or locking devices; the final rule clarifies that the stepladder must be “equipped” with those devices when used by an employee.

Final paragraph (c)(2) does not retain language in the existing rules requiring that employers remove or cover sharp points or edges on spreaders (§§ 1910.25(c)(2)(i)(f) and 1910.26(a)(3)(viii)). OSHA believes that final § 1910.23(b)(7), which requires employers to ensure ladder surfaces are free of puncture and laceration hazards adequately addresses that issue. Thus, OSHA believes that it is not necessary to repeat that requirement in final paragraph (c)(2). OSHA did not receive any comments on the proposed deletion.

Final paragraph (c)(3) requires that employers not load portable ladders beyond their maximum intended load. A note to final paragraph (c)(3) reminds employers that maximum intended load includes the weight and force of workers and the tools, equipment, and materials workers are carrying, which is consistent with the definition of "maximum intended load" in final § 1910.21(b).

The final rule differs from both the existing and proposed rules. The existing rule requires that portable ladders be capable of withstanding a 200-pound load. In the proposed rule, OSHA required that employers ensure that the weight on portable ladders not exceed the weight "for which they were designed and tested, or beyond the manufacturer's rated capacity."

After further analysis, OSHA removed the proposed language from final paragraph (c)(3) for the following reasons. First, OSHA believes that requiring employers to ensure each ladder supports its maximum intended load is comprehensive, and the additional language in the proposed rule is not necessary. OSHA believes that the language in the "maximum intended load" definition (*i.e.*, "loads reasonably anticipated to be applied to a walking-working surface") will ensure that the load on a ladder will not exceed the weight for which the ladder was designed or tested, or the manufacturer's rated capacity.

Second, removing the additional language in the proposal makes final paragraph (c)(3) consistent with final § 1910.22(b), and easier to understand. Third, OSHA believes that including the proposed language "manufacturer's rated capacity" in the final rule may cause confusion about whether the provision applies to both job-made ladders and manufactured ones. The language in the final standard clearly reads that the requirement applies to all types of portable ladders.

OSHA notes that, unlike the performance-based language in final paragraph (c)(3), the construction ladder standard requires that portable ladders meet specific load requirements (§ 1926.1053(a)(1)). As discussed above, one of the goals of this rulemaking is to make the final rule consistent with the construction standard. Accordingly, OSHA will consider employers who ensure their portable ladders meet the load requirements in § 1926.1053(a)(1) as being in compliance with final paragraph (c)(3). OSHA did not receive any comments on the proposed provision and finalizes the provision as discussed.

Final paragraph (c)(4), like the proposed rule, requires that employers ensure portable ladders are used only on stable and level surfaces unless they are secured or stabilized to prevent accidental displacement. When the footing of ladders is not stable or level and the ladder is not secure, the ladder can slip out of place or tip over because of workplace activities, traffic, and weather conditions (*e.g.*, high winds). According to the A14.1–2007 standard, lack of stability and sliding of the ladder are the major causes of falls from self-supporting ladders, while lateral sliding at the top of the ladder and outward sliding of the ladder at the lower base support are major causes of falls from non-self-supporting portable ladders (A14.1–2007, Section 8.1.3).

The final rule consolidates and revises the existing portable ladder rules, which requires placing portable ladders so they have "secure footing" (§§ 1910.25(d)(2)(iii) and 1910.26(c)(3)(iii)). The final rule further clarifies that employers can ensure secure footing for portable ladders either by (1) placing them on a stable and level surface, or (2) securing or stabilizing them.

Depending on the type of ladder and the conditions of use, securing or stabilizing portable ladders may be as simple as using swivel or rubber ladder feet, or may involve more complex procedures such as using ladder levelers to equalize side rail support. The A14.1–2007 and A14.2–2007 standards provide useful guidance about methods employers can use to secure portable ladders, including foot ladder boards and similar devices.

Final paragraph (c)(4) does not carry forward language in existing § 1910.25(d)(2)(iii) requiring that the top rest for portable ladders be reasonably rigid and have ample strength to support the supplied load. OSHA believes final paragraph (c)(10) adequately addresses the hazard, so the language in the existing rule is no longer needed. The final rule requires placing the bottom and top of ladder side rails on a stable and level surface, or securing and stabilizing the ladder. Unless the employer addresses the stability of both ends of the ladder, the ladder is not safe for workers to use.

Final paragraph (c)(4) is almost identical to OSHA's construction ladder standard (§ 1926.1053(b)(6)), and is consistent with OSHA's maritime ladder standards (§§ 1915.72(a)(3); 1917.119(f)(8); and 1918.24(j)(1) and (2)). The final rule also is consistent the A14 portable ladder standards (A14.1–2007, Section 8.3.4; and A14.2–2007, Section 8.3.4). OSHA did not receive

any comments on the proposed provision.

Final paragraph (c)(5), like the existing and proposed rules, requires that employers ensure workers do not use portable single-rail ladders. OSHA's construction ladder standard (§ 1926.1053(b)(19)), which also prohibits using single-rail ladders, defines them as "a portable ladder with rungs, cleats, or steps mounted on a single rail instead of the normal two rails used on most other ladders" (§ 1926.1050(b)). In the preamble to the final construction ladder rule, OSHA said, "Single-rail ladders are inherently difficult to use because of their instability" (55 FR 47681). OSHA believes that use of single-rail ladders in general industry also poses the same hazards. OSHA notes the prohibition in the existing rule has been in place since OSHA adopted it in 1971 from national consensus standards available at the time.

Although the A14.1–2007 standard does not contain the prohibition on single-rail ladders that was in A14.1–1968, OSHA believes it is clear that A14.1–2007 and A14.2–2007 do not cover or endorse their use. The definition of portable ladder in both of these standards indicates that they consist of "side rails, joined at intervals by rungs, steps, cleats or rear braces" (A14.1–2007, Section 4; and A14.2–2007, Section 4). OSHA notes that A14.1–2007 and A14.2–2007 do not address single-rail ladders, which indicates that their use is not generally accepted industry practice.

Mr. Robert Miller, a senior safety supervisor with Ameren, opposed the prohibition on single-rail ladders, arguing:

I don't feel it is necessary to eliminate what for an employer may be the safest most feasible method of accessing another level of the work area if that employer can show by training, performance and history that the single rail ladder poses no greater hazard than another method (Ex. 189).

Mr. Miller recommended that OSHA allow employers to demonstrate by training, performance, and history that the single-rail ladder poses no greater hazard than any other method (Ex. 189). However, Mr. Miller did not provide a single example of when using a single-rail ladder would be as safe, or safer, than using portable ladders with two side rails. Accordingly, Mr. Miller did not convince OSHA to remove from the final standard the prohibition on using single-rail ladders.

OSHA notes that, in an enforcement action, employers may raise the affirmative defense of greater hazard. Employers raising this defense have the

burden of proving that complying with the OSHA standard poses a greater hazard to employees than complying with the standard and no alternative means of employee protection are available. OSHA observes that Ameren did not present any information or evidence that would meet this burden.

Final paragraph (c)(6), like the proposal, adds a new requirement that employers ensure a ladder is not moved, shifted, or extended while a worker is on it. Moving, shifting, or extending an occupied ladder is dangerous to workers, whether it is the worker on the ladder who moves (“hops”) it or a worker on the ground who moves the ladder while a worker is on the ladder. Moving, shifting, or extending an occupied ladder could cause the worker to fall off the ladder or cause the ladder to tip over. According to the A14.1–2007 standard, a leading factor contributing to falls from portable ladders is movement of the ladder (A14.1–2007, Section 8.1.5).

OSHA drew this provision from the construction ladder standard (§ 1926.1053(b)(11)). The A14.1–2007 and A14.2–2007 standards also prohibit “relocating” a ladder while a worker is on it (A14.1–2007, Section 8.3.15; and A14.2–2007, Section 8.3.15). OSHA did not receive any comments on the proposed provision.

Final paragraph (c)(7), consistent with the proposed rule, requires that employers ensure ladders placed in locations where other activities or traffic can displace them (e.g., passageways, doorways, and driveways) are:

- Secured to prevent accidental displacement (final paragraph (c)(7)(i)); or
- Guarded by a temporary barricade, such as a row of traffic cones or caution tape, to keep activities or traffic away from the ladder (final paragraph (c)(7)(ii)).

Final paragraph (c)(7) is consistent with the existing rule, which requires that employers must not place ladders in front of doors unless the door is blocked, locked, or guarded (§ 1910.25(d)(2)(iv)). OSHA believes the final rule retains the flexibility of the existing rule and identifies additional measures employers can use to prevent activities and traffic from striking ladders that are near passageways, doorways, or driveways, which may cause workers located on the ladders in those areas to fall. For example, to prevent injury to workers while they work on ladders by a doorway, employers can “secure” the area by simply locking the door so no one can open it and strike the ladder, or “guard” the door using a temporary barricade of

traffic cones or caution tape. If the doorway is a required exit route (see 29 CFR part 1910, subpart E) that cannot be locked or blocked, the final rule allows employers the flexibility to “guard” the doorway by posting a monitor to control passage through the door.

Final paragraph (c)(7) is almost identical to OSHA’s construction ladder standard (§ 1926.1053(b)(8)). It also is consistent with A14.1–2007 (Section 8.3.12) and A14.2–2007 (Section 8.3.12).

Final paragraph (c)(8) requires that employers ensure that employees do not use the cap, if equipped, and the top step of a stepladder as steps. The purpose of final paragraph (c)(8) is to clarify that the existing and proposed rules, which state that employers must not use the “top of a stepladder,” includes both the top step of the stepladder and top cap of the stepladder. Using either surface as a step may decrease the ladder’s stability and cause it to fall over, injuring the worker.

Final paragraph (c)(8) is almost identical to OSHA’s construction ladder standard (§ 1926.1053(b)(13)), and is consistent with both A14.1–2007 (Section 8.3.2(1)) and A14.2–2007 (Section 8.3.2(1)). OSHA did not receive any comments on the proposed provision.

Final paragraph (c)(9) requires that employers ensure portable ladders used on slippery surfaces are secured and stabilized. For the purposes of this paragraph, slippery surfaces include, but are not limited to, environmental (e.g., rain, snow, ice) and workplace conditions (e.g., oil, grease, solvents). When any of these conditions make walking-working surfaces slippery, it is important that employers secure and stabilize ladders to prevent displacement, which could cause workers to fall. Final paragraph (c)(9) is a companion provision to final paragraph (c)(4), which requires that employers ensure portable ladders are used only on stable and level surfaces unless they are secured or stabilized to prevent displacement.

The final rule gives employers flexibility in selecting measures to secure or stabilize ladders that they use. Consistent with OSHA’s construction ladder standard (§ 1926.1053(b)(7)), in appropriate situations employers may use ladders equipped with slip-resistant feet to secure and stabilize them on slippery surfaces. However, employers may not be able to rely on the use of ladders with slip-resistant feet in all cases where surfaces are slippery. In some conditions it may be necessary for employers to take additional or other measures, such as lashing, to secure and

stabilize portable ladders. For example, the construction ladder standard specifies that slip-resistant feet shall not be used as a substitute for holding a ladder that is used upon slippery surfaces including, but not limited to, flat metal or concrete surfaces that are constructed so they cannot be prevented from becoming slippery (§ 1926.1053(b)(7)).

OSHA notes the final rule covers all portable ladders while the proposed rule only would have applied the requirement to portable ladders that are not self-supporting. OSHA revised the final rule for two reasons. First, although under final paragraph (c)(4) OSHA considers slippery surfaces to be unstable for all types of portable ladders, the Agency is expressly applying final paragraph (c)(9) to all portable ladders to make sure the hazard is clearly addressed. For example, self-supporting ladders that are not equipped with slip-resistant feet can move or slide in slippery conditions, which can cause the worker to fall off the ladder. The revision ensures that the final rule protects workers from this hazard.

Second, the revision of final paragraph (c)(9) makes the provision consistent with the construction ladder standard, which applies to all ladders (§ 1926.1053(b)(7)). Applying final paragraph (c)(9) to all portable ladders also makes the final rule consistent with A14.1–2007 (Section 8.3.4) and A14.2–2007 (Section 8.3.4), which address all wood and metal portable ladders, as well as Section 6(b)(8) of the OSH Act (29 U.S.C. 655(b)(8)). Section 6(b)(8) specifies that whenever an OSHA standard differs substantially from an existing national consensus standard, the Agency must explain why the adopted rule better effectuates the purposes of the OSH Act. OSHA believes the revised provision will protect all workers using any type of portable ladder, and therefore best effectuates the OSH Act. OSHA did not receive any comments on the proposed provision.

Final paragraph (c)(10), like both the existing and proposed rules, requires that employers ensure that employees place the top of non-self-supporting ladders so that both side rails are supported, unless the ladders are equipped with single support attachments. Final paragraph (c)(10) revises the existing rule (§ 1910.26(c)(3)(iv)) by adding the term “non-self-supporting” to clarify that it is non-self-supporting ladders that need to be supported before workers attempt to use them. Self-supporting ladders must not be used as non-self-supporting

ladders (see final paragraph (b)(8); *see also*, A14.1–2007, Section 8.3.5)). The final rule is identical to OSHA’s construction ladder standard (§ 1926.1053(b)(10)), and is consistent with both A14.1–2007 (Section 8.3.5) and A14.2–2007 (Section 8.3.5). OSHA did not receive any comments on the proposed provision.

Final paragraph (c)(11), like the existing and proposed rules, requires that employers ensure portable ladders used to gain access to an upper landing surface have side rails that extend at least 3 feet above the upper landing surface. OSHA believes that retaining the existing requirement is important because transitioning from ladders to upper landing surfaces is hazardous to workers. Requiring the ladder side rails to extend 3 feet above the upper landing surface ensures that workers have adequate support and hand holds so they can access the upper landing surface safely. OSHA’s construction ladder standard (§ 1926.1053(b)(1)), A14.1–2007 (Section 8.3.10), and A14.2–2007 (Section 8.3.10) also require that portable ladders extend 3 feet above the upper landing surface.

OSHA received one comment on the proposal. Ellis Fall Safety Solutions (Ex. 329 (1/21/2011, p. 260)) said OSHA should recognize attaching extensions onto the end of side rails as an acceptable means to comply with the 3-foot extension requirement. In the proposal, OSHA noted that employers may use after-market ladder extensions to increase the length of a ladder to meet proposed paragraph (c)(11), provided:

- The after-market rail extensions “are securely attached (that is, secured to the extent necessary to stabilize the extension and not expose the employee to a falling hazard from the extension’s displacement)”;
- The ladder to which the after-market rail extensions is attached is “specifically designed for the application” in accordance with proposed paragraph (c)(14).

OSHA said that side-rail extensions that meet these requirements “would be considered part of the ladder itself” (75 FR 28877). In 2005, OSHA permitted use of after-market rail extensions under the construction ladder standard if the ladders meet the requirements above (see letter to Mr. Bruce Clark, president of American Innovations Corporation, December 22, 2005).²⁰ Based on the record as a whole, OSHA concludes that employers may use after-market rail

extensions to meet the requirement of final paragraph (c)(11), provided that the ladders meet these requirements.

Final paragraph (c)(12), like proposed paragraph (c)(13), requires that employers not use ladders and ladder sections tied or fastened together to provide added length unless the ladder design specifically permits such use. The purpose of the final paragraph is to prevent the use of unsafe rigging methods and to use ladders only as they were intended. Ladders gerry-rigged to provide longer lengths are not likely to be as strong and stable as ladders designed to reach such heights.

Limiting fastening together ladders and ladder sections to those “specifically designed for such use” means that the designer developed both the ladders and any mechanism used to connect them specifically to achieve greater length. The final rule revises existing § 1910.26(c)(3)(v), which specifies that the manufacturer must equip the ladders and ladder sections with necessary hardware fittings, if the manufacturer endorses allowing such ladder extensions, to ensure that the requirement covers both manufactured and job-made ladders and ladder sections. Therefore, under the final rule the ladder designer, regardless of whether employed by the employer, a manufacturer, or other company, must develop the ladder or ladder section specifically for the purpose of fastening them together to extend the length of the ladder or the employer must not fasten the ladder or ladder sections together. Final paragraph (c)(12) is consistent with existing § 1910.25(d)(2)(ix), A14.1–2007 (Section 8.3.11), and A14.2–2007 (Section 8.3.11).

Final paragraph (c)(13) retains the language in existing § 1910.25(d)(2)(v), which prohibits placing ladders on boxes, barrels, or other unstable bases to obtain additional height. The proposed rule (proposed paragraph (c)(14)) prohibited employers from increasing the reach of ladders and ladder sections by any means not permitted specifically by the design of the ladders. After further analysis, OSHA believes the language in the existing rule is clearer and easier to understand than the proposed language. The language also is the same as A14.1–2007 (Section 8.3.4) and A14.2–2007 (Section 8.3.4).

For the purposes of final paragraph (c)(13), unstable bases include surfaces such as vehicles, truck flatbeds, scaffolds, and stairs. OSHA received one comment on the proposed provision. Southern Company (Ex. 192) asked whether paragraph (c)(13) prohibited the use of ladder-leveling devices that extend the reach of the ladder. Final

paragraph (c)(12) addresses fastening together ladders and ladder sections. However, OSHA does not consider ladder-leveling devices to be ladders or ladder sections. Rather they are devices attached to ladder side rails and allow for independent adjustment of the rails to ensure the ladder is level. Like the A14 standards, OSHA considers ladder-leveling devices to be “ladder accessories . . . that may be installed on or used in conjunction with ladders” (A14.1–2007, Section 1.1; and A14.2–2007, Section 1.1). Although ladder-leveling devices may be temporary or permanent attachments to the ladder, OSHA does not consider ladder-leveling devices to be “part of the ladder itself” (75 FR 28877). Therefore, final paragraph (c)(13) does not apply to ladder-leveling devices, even if they increase the length of the ladder.

That said, other provisions in §§ 1910.22 and 1910.23 (*e.g.*, final paragraphs (b)(8) and (c)(4)) are applicable when employers use ladder-leveling devices. For example, paragraph (b)(8) mandates that employers use ladders only for their intended purpose. OSHA believes that employers are using ladders for their intended purpose only when the design of the accessories attached to, or used in conjunction with, the ladders permit such use. OSHA notes that there are many after-market ladder devices that employers may attach to, or use in conjunction with, ladders. Many of these devices, including ladder-leveling devices, can help to make ladders safer for workers to use. OSHA is not prohibiting the use of ladder accessories that can make ladders safer for workers to use. However, after-market add-ons must meet the standard’s requirements. That is, when in use, the additional device must not reduce the ladder’s strength or stability, and employers must use them only for their designed purpose. Although allowed, OSHA cautions employers against using job-made devices unless a professional engineer designed and certified them. OSHA notes that the Agency does not approve or endorse specific products.

Paragraph (d)—Fixed Ladders

Final paragraph (d) establishes requirements that apply to fixed ladders, in addition to the requirements in final paragraph (b). The final rule defines “fixed ladder” as a ladder, with side rails or individual rungs, that is permanently attached to a structure, building or equipment (§ 1910.21(b)). Fixed ladders do not include ship stairs, stepbolts, or manhole steps.

Final paragraph (d)(1), like the proposed rule, establishes a

²⁰ OSHA letter to Mr. Bruce Clark available at: http://www.osha.gov/pls/oshaweb/owadisp.show_document?p_table=INTERPRETATIONS&p_id=25177.

performance-based provision requiring that employers ensure any fixed ladder a worker uses is capable of supporting the maximum intended load. As discussed in § 1910.22, and above in this section, “maximum intended load” means “the total load (weight and force) of all employees, equipment, vehicles, tools, materials, and loads the employer reasonably anticipates to be applied to a walking-working surface” (§ 1910.21(b)).

The performance-based language in final (d)(1) replaces the detailed specification requirements in the existing rules (§ 1910.27(a)(1)(i) through (iv) and (a)(2)). OSHA requested comment on whether the Agency should retain the specification requirements in existing § 1910.27(a)(1), but did not receive any comments.

OSHA did not adopt proposed paragraph (d)(2) as a companion to proposed paragraph (d)(1). Proposed paragraph (d)(2) required that employers ensure fixed ladders installed on or after 150 days after issuing the final rule meet specific design, construction, and maintenance requirements, including supporting two 250-pound live loads. The existing rule requires that fixed ladders support a single concentrated 200-pound load (§ 1910.27(a)(1)). After additional analysis, OSHA decided to adopt proposed paragraph (d)(1), and not retain existing § 1910.27(a) or adopt proposed paragraph (d)(2). First, OSHA believes the maximum load requirement in final paragraph (d)(1) is as safe as, or more protective than, the existing and proposed rules. Final paragraph (d)(1) requires that employers ensure that a fixed ladder meets the maximum load that the designer specifically established for that particular fixed ladder. OSHA believes that following the load requirement established for a particular ladder is at least as safe as a general specification (200 or 250 pounds) applied to all fixed ladders.

Second, OSHA believes the performance-based approach in final paragraph (d)(1) is easier to understand and follow than the minimum weight specifications in the existing and proposed rules. In addition, the final rule gives employers greater flexibility in selecting and using fixed ladders. OSHA notes that Ameren (Ex. 189), among other commenters, supported the use of performance-based language for this and other provisions in the final rule.

Third and finally, not adopting the proposed rule, which had an effective date 150 days after publication of the final rule, addresses commenters’ concerns that that OSHA failed to give adequate lead-in time to come into

compliance with the new requirement (Exs. 189; 192).

Final paragraph (d)(2), like proposed paragraph (d)(3), requires that employers ensure the minimum perpendicular distance from the ladder to the nearest permanent object in back of the ladder is 7 inches. The final rule requires that this distance be measured from the centerline of the fixed ladder steps and rungs or grab bars, or both, to the object in back of the ladder (*e.g.* wall). OSHA believes the 7-inch minimum will ensure that workers have adequate space to get a safe foothold on fixed ladders. Final paragraph (d)(2) also includes an exception for elevator pit ladders. For these ladders, the employer must ensure that the minimum perpendicular distance is 4.5 inches.

Final paragraph (d)(2), like the proposal, revises the existing rule (§ 1910.27(c)(4) and (5)) in several ways. First, the final rule replaces the existing 4-inch minimum perpendicular distance for grab bars with a 7-inch minimum clearance. To ensure worker safety while they climb fixed ladders and transition to upper landing surfaces, OSHA believes that the minimum perpendicular distance for grab bars needs to be the same as the minimum perpendicular distance specified for ladder rungs and steps.

Second, final paragraph (d)(2) eliminates an exception from the 7-inch clearance requirement for “unavoidable obstructions” (§ 1910.27). OSHA stated in the preamble to the final construction ladder standard that “the minimum clearance requirement is necessary, regardless of any obstructions, so that employees can get safe footholds on ladders” (55 FR 47675).

Third, final paragraph (d)(2) adds a new exception that reduces the minimum perpendicular clearance in elevator pits to 4.5 inches. OSHA drew this exception from the construction ladder standard (§ 1926.1053(a)(13)). The exception is consistent with the ANSI/ASME A17.1–2010, Safety Code for Elevators and Escalators (Section 2.2.4.2.4) (Ex. 380). Generally, space in elevator pits is restricted, and it may not be possible to have a 7-inch clearance. In the preamble to the construction ladder standard, OSHA said the exception for elevator pit ladders was appropriate because elevator shafts generally are secure from unauthorized access (55 FR 47675). As such, only workers who have the required equipment and fall protection training would be accessing the elevator pit (55 FR 47675). Under the final rule, employers must train each worker in the proper use of equipment, including

fixed ladders, before permitting any worker to use the equipment (§ 1910.30(b)(1)).

One of OSHA’s goals in revising the existing rule (§ 1910.27(c)(4)) was to make the final rule consistent with OSHA’s construction ladder standard, and final paragraph (d)(2) is almost the same as that rule (§ 1926.1053(a)(13)). The construction standard also contains language specifically indicating that the required 7-inch clearance also applies to obstructions. In addition, the final rule is consistent with the 7-inch minimum perpendicular distance in existing § 1910.27(c)(4) and A14.3–2008 (Section 5.4.2.1).

OSHA received one comment from Southern Company (Ex. 192). They asked to grandfather in the existing requirement because they have many fixed ladders and “[r]edesigning or moving any of these ladders to avoid these obstructions could be expensive or in some cases infeasible.” OSHA does not believe that grandfathering is necessary. The Agency believes the vast majority of fixed ladders currently in use comply with the final requirement because the final rule reflects requirements in place under ANSI A14.3 since 1974. In addition, OSHA’s construction standard has required the same clearance since the Agency adopted it in 1994.

Final paragraphs (d)(3) through (8) establish requirements for ladder extension areas to ensure that workers are able to transition safely from the fixed ladder to the landing surface. In particular, several of the provisions apply to through and side-step ladders. The A14.3–2008 standard defines through ladders as rail ladders that require a worker getting off to step through the ladder to reach the landing (A14.3–2008, Section 3). That standard also defines side-step ladders as rail ladders that require workers getting off at the top to step sideways from the ladder to reach the landing (A14.3–2008, Section 3).

Final paragraph (d)(3), like the existing (§ 1910.27(c)(5)) and proposed rules, requires that employers ensure grab bars on the climbing side do not protrude beyond the rungs of the ladder they serve. The final rule defines grab bars as individual vertical or horizontal handholds that provide access above the ladder height (§ 1910.21(b)). Grab bars that protrude beyond the rungs of the ladder can be hazardous because they make it more difficult to climb and transition to landing surfaces. To illustrate, having the grab bars protrude further than the ladder would put the worker at an angle greater than 90 degrees and make climbing and holding

on more difficult, which makes a fall more likely. OSHA did not receive any comments on the proposed provision.

Final paragraph (d)(4), like the proposed rule, establishes requirements for through and side-step ladders, including those ladders used on buildings with parapets. The final rule requires that employers ensure the side rails of through or side-step ladders extend 42 inches above the top of the access level or platform served by the ladder.

Final paragraph (d)(4) also adds language specifying what constitutes the "access level" for through and side-step ladders on buildings that have parapets. When a parapet has an opening that permits passage through it (*i.e.*, through ladder), the final rule specifies that the access level is the roof (final paragraph (d)(4)(i)). For parapets without such an opening (*i.e.*, side-step ladders), the final rule specifies the access level is the top of the parapet (final paragraph (d)(4)(ii)). OSHA added this language to clarify the Agency's intent that workers must have sufficient handholds at least 42 inches above the highest level on which they will step when reaching the access level, regardless of the location of the access level (*i.e.*, roof or top of parapet). The language also makes the final rule consistent with § 1926.1053(a)(24) and A14.3–2008 (Section 5.3.2.1). OSHA did not receive any comments on the proposed provision.

Final paragraph (d)(5), like the existing (§ 1910.27(d)(3)) and proposed rules, specifies that employers ensure that there are no steps or rungs on the portion of the through ladder extending above the access level. It is obvious that this requirement is necessary to allow workers to pass the ladder and step onto the upper landing surface. The final rule is the same as OSHA's construction ladder standard (§ 1926.1053(a)(25)) and A14.3–2008 (Section 5.3.2.2).

In addition, final paragraph (d)(5), like the proposed rule, also requires flared extensions of the side rails above the access level to provide clearance of not less than 24 inches and not more than 30 inches. The final rule increases the existing clearance width (from 18 to 24 inches) between the side rails. OSHA believes the additional clearance will help to ensure that workers equipped with personal fall protection systems, tools, and other items have adequate space to negotiate the pass-through area and reach the upper landing safely. The increased clearance width makes the final rule consistent with OSHA's construction standard (§ 1926.1053(a)(25)) and A14.3–2008 (Section 5.3.2.2).

Final paragraph (d)(5) adds a new clearance width requirement for through ladders equipped with ladder safety systems. In those cases, the final rule requires that employers ensure the clearance between side rails of the extensions does not exceed 36 inches. The new provision makes the final rule consistent with OSHA's construction ladder standard (§ 1926.1053(a)(25)). OSHA did not receive any comments on the proposed provision.

Final paragraph (d)(6), like the proposed rule, adopts a performance-based revision of the existing rule for side-step ladders (§ 1910.27(d)(3)). Accordingly, the final rule requires that employers ensure the side rails, rungs, and steps of side-step ladders be continuous in the extension. The existing rule, by contrast, specifies that the landings of side-step or off-set fixed ladder sections have side rails and rungs that extend to the next regular rung above or beyond the 42-inch minimum extension. OSHA believes the performance-based revision makes the final rule easier to understand and follow. The final rule is consistent with OSHA's construction standard (§ 1926.1053(a)(24)) and A14.3–2008 (Section 5.3.2.3).

Final paragraphs (d)(7) and (8) specify criteria for grab bars. Final paragraph (d)(7), like the proposed rule, requires that employers ensure grab bars extend 42 inches above the access level or landing platforms of the ladder, which is the same height required for side rails in the extension area of through and side-step ladders (see final paragraph (d)(4)). Final paragraph (d)(7) revises and clarifies the existing rule (§ 1910.27(d)(4)), which states that grab bars "be spaced by a continuation of the rung spacing when they are located in the horizontal position," and have the same spacing as ladder side rails when located in the vertical position. The final rule identifies, more clearly and exactly, the required location (*i.e.*, above the access level or platform) and height (*i.e.*, 42 inches) of the grab bars. OSHA believes that employers will find the final rule easier to understand and follow.

OSHA drew the language in final paragraph (d)(7), in part, from its construction ladder standard (§ 1926.1053(a)(27)) and A14.3–2008 (Sections 5.3.3.1 and 5.3.3.2). The final rule expands application to grab bars on all fixed ladders; OSHA's construction ladder standard and A14.3–2008 only apply to individual-rung ladders. Also, the final rule does not include the exception in OSHA's construction standard and A14.3–2008 for manhole steps, covers, and hatches because

manhole steps are not considered ladders in this rule and are covered in a separate section (final § 1910.24). OSHA did not receive any comments on the proposed provision.

Final paragraph (d)(8), like the existing (§ 1910.27(d)(4)) and proposed rules, requires that employers ensure the minimum size (*i.e.*, cross-section or diameter) of the grab bars are the same size as the rungs on that ladder. The final rule clarifies the existing rule by specifying that the grab bars and rungs of fixed ladders be the same size (diameter). The final rule is consistent with A14.3–2008 (Section 5.3.3.3).

OSHA received one comment about grab bars. Nigel Ellis, Ellis Safety Solutions, LLC (Ex. 155), recommended that the final rule require horizontal grab bars, especially if the length of vertical grab bar exceeds 6 inches. He pointed to a study (Young et al., "Handhold Coupling: Effect of Handle Shape, Orientation, and Friction on Breakaway Strength," 51 Human Factors 705, October 2009) showing that breakaway strength (*i.e.*, the maximum force that can be exerted on an object before it pulls away or slips from the grasp of the hand) was greatest for fixed horizontal cylindrical-shaped bars (Ex. 344). Based on that study, Mr. Ellis said that it would be more likely that workers could arrest a fall by grabbing a horizontal, rather than a vertical, grab bar. He also said, "It has been shown that vertical grab bars are a sliding element that prevents an adequate grip to stop a fall," and concluded that "if a vertical grab bar exceeds 6 inches vertically then the hand-sliding fall is unstoppable" (Ex. 344).

OSHA agrees that horizontal bars provide the possibility of stronger grips than vertical ones in the event of a fall from a ladder when a ladder safety system or a personal fall protection system is not taken into account. However, horizontal grab bars do not provide the level of protection from falls that ladder safety systems and personal fall protection systems provide. Given that ladder safety systems and personal fall protection systems will increasingly protect workers who climb ladders from falling, OSHA does not believe it is necessary at this point to require installation of horizontal grab bars when any vertical grab bar exceeds 6 inches.

Final paragraph (d)(9), like the proposed rule, establishes two requirements for ladders that terminate at hatch covers. First, the final rule requires that employers ensure that the hatch cover opens with sufficient clearance to provide easy access to or from the ladder (see final paragraph (d)(9)(i)). Second, the final rule requires

that employers ensure counterbalanced hatch covers open at least 70 degrees from the horizontal (see final paragraph (d)(9)(ii)). In essence, this provision defines in objective terms (70 degrees) what constitutes “sufficient clearance,” as used in the existing rule (§ 1910.27(c)(7)).

Final paragraph (d)(9), like the proposal, revises the existing rule in two ways. First, the final rule increases to 70 degrees the angle to which counterbalanced hatch covers must open. The existing rule only requires that hatch covers open a minimum of 60 degrees, but also specifies that the minimum distance from the centerline of the top rung be at least 24 inches for ladders with “offset wells,” and at least 30 inches for “straight wells.” OSHA believes that increasing the opening to 70 degrees will ensure that the space between the top rung and hatch provides adequate clearance regardless of what type of fixed ladder is used.

Second, the final rule replaces the specification requirement in the existing rule with performance-based language. The performance-based language ensures that the final rule provides a level of worker safety that is as great as or greater than the existing rule, but gives employers the flexibility to determine how counterbalanced hatch covers will open to 70 degrees. The performance-based language also makes final paragraph (d)(9) clearer and easier to follow than the existing rule. The final rule is consistent with A14.3–2008 (Section 5.3.4.2). OSHA notes that A14.3–2008 also includes language similar to the specification language in the existing rule, but the language is only advisory. OSHA did not receive any comments on the proposed provision.

Final paragraph (d)(10), like the existing (§ 1910.27(b)(1)(v)) and proposed rules, requires that employers ensure that the construction of individual-rung ladders will prevent the worker’s feet from sliding off the ends of the rungs (Figure D–4 in regulatory text illustrates). OSHA believes this requirement is essential because individual-rung ladders do not have side rails to block the worker’s feet from sliding off the rung. Final paragraph (d)(10) is the same as OSHA’s construction industry standard (§ 1926.1053(a)(5)). OSHA did not receive any comments on the proposed provision.

Final paragraph (d)(11), like the proposed rule, requires that employers ensure workers do not use fixed ladders that have a pitch greater than 90 degrees from the horizontal. A ladder that exceeds a pitch of 90 degrees makes the

ladder dangerous to climb because pitch greater than 90 degrees would require climbers to exert considerable extra force to maintain their grip on the ladder against the gravitational force. The final rule revised the specification approach in the existing requirements (§ 1910.27(e)(1) through (4)), and replaces it with performance-based language. OSHA believes much of the language in the existing rule continues to provide useful information best included in compliance-assistance documents. OSHA did not receive any comments on the proposed paragraph.

Final paragraph (d)(12), like the proposed rule, addresses step-across distances for through and side-step ladders. Specifically, final paragraph (d)(12)(i) requires that employers ensure the step-across distance for through ladders is not less than 7 inches, and not more than 12 inches, to the nearest edge of the structure, building, or equipment accessed from the ladders, measured from the centerline of the ladder. Final paragraph (d)(12)(ii) requires that employers ensure the step-across for side-step ladders is at least 15 inches, but not more than 20 inches, measured from the centerline of the ladder to the nearest point of access on the platform edge.

The final rule, like the proposal, revises the existing rule in § 1910.27(c)(6) in several ways. First, the final rule establishes specific step-across distances for each through and side-step ladder (§ 1910.27(c)(6)). The existing rule establishes a single step-across distance applicable to all fixed ladders. Compared to the existing rule, OSHA believes the final rule more appropriately tailors the step-across distances to the type of ladder used, which improves worker safety.

Second, final paragraph (d)(12) revises the existing step-across distance (*i.e.*, not less than 2.5 inches and not more than 12 inches) to make transitioning from the ladder to the upper landing surface safer and consistent with other provisions in the final rule. OSHA believes that a 2.5-inch step-across distance could conflict with the 7-inch minimum perpendicular clearance requirement in final paragraph (d)(2). The 7-inch clearance requirement is necessary to ensure that workers will have a safe foothold on the ladder. If the existing rule inadvertently results in workers having an inadequate foothold on the top of the ladder, it could increase the worker’s chance of falling.

Third, the final rule does not retain the companion provision in the existing rule (§ 1910.27(d)(1)) that requires employers to provide a landing platform

if the step-across distance is greater than 12 inches. OSHA believes that the final rule already addresses this issue; therefore, it is not necessary to retain the requirement.

Final paragraph (d)(12) requires that employers measure step-across distance from the centerline of the ladder to the “nearest edge of the structure, building, or equipment.” Thus, in the final rule, the nearest edge of a structure may be a landing platform. Final paragraph (d)(12) is consistent with OSHA’s construction ladder standard (§ 1926.1053(a)(16)) and A14.3–2008 (Section 5.4.2.2). OSHA did not receive any comments on the proposed provision.

Final paragraph (d)(13) addresses fixed ladders that do not have cages or wells. Final paragraph (d)(13)(i), like the existing (§ 1910.27(c)(2)) and proposed rules, requires that employers ensure ladders without cages or wells have a clear width of at least 15 inches on each side of the ladder centerline to the nearest object. Having at least a 15-inch minimum clearance on the ladder is necessary to provide adequate clearance to climb the ladder and prevent damage to the ladder. Figure D–2 illustrates this requirement, which is consistent with OSHA’s construction ladder standard (§ 1926.1053(a)(17)) and A14.3–2008 (Section 5.4.3.1).

Final paragraph (d)(13)(ii), like the proposed rule, requires that employers ensure there is a minimum perpendicular distance of 30 inches from the centerline of the steps or rungs to the nearest object on the climbing side of the ladder. The final rule, like the proposal, revises the existing requirement in § 1910.27(c)(1) in three ways. First, the final rule replaces the existing requirement that the pitch of the ladder be the basis of the minimum perpendicular distance (*i.e.*, 36 inches for 75-degree pitch ladder and 30 inches for 90-degree pitch ladders) with a single, minimum clearance, regardless of the ladder pitch. OSHA believes that the revised rule will not pose problems for employers because the pitch of virtually all fixed ladders is 90 degrees. As such, the final rule is consistent with the existing rule. The revision in the minimum perpendicular clearance makes the final rule consistent with OSHA’s construction ladder standard (§ 1926.1053(a)(14)) and A14.3–2008 (Section 5.4.1.1).

Second, the final rule provides an exception to the minimum perpendicular clearance requirement “[w]hen unavoidable obstructions are encountered.” The final rule allows a reduction of the minimum clearance to 24 inches in those cases, provided that

employers install deflector plates. The deflectors will protect workers on fixed ladders by guiding them around unavoidable obstructions. Adding this exception makes the final rule consistent with OSHA's construction ladder standard (§ 1926.1053(a)(15)) and A14.3–2008 (Section 5.4.1.3).

Third, final paragraph (d)(13) recasts the existing rule so it is more performance-based. OSHA believes this change makes the final rule easier to understand and follow than the existing rule.

OSHA received one comment on the proposed provision. Ameren Corporation stated:

As long as the fixed ladders in any facility comply with the current "inches clearance per pitch" requirements, they should be grandfathered in due to the potential financial impact and minimum difference in clearance as well as any history of no apparent difficulties with head clearance by way of reviewing incident reporting trends (Ex. 189).

OSHA does not agree with Ameren that the revisions to the minimum perpendicular clearance on the climbing side of fixed ladders will have any significant financial impact on employers who are in compliance with the existing rule. As mentioned earlier, almost all fixed ladders have a 90-degree pitch, which means that they must already meet the 30-inch clearance requirement of the existing rule. Therefore, the vast majority of employers would not have to replace their ladders since they are in compliance with the existing provision.

Final paragraph (d) includes an informational note stating that §§ 1910.28 and 1910.29 establish, respectively, the duty to provide fall protection for workers using fixed ladders and the mandatory criteria for that fall protection.

Paragraph (e)—Mobile Ladder Stands and Mobile Ladder Stand Platforms

Final paragraph (e) establishes requirements that apply to mobile ladder stands and mobile ladder stand platforms (mobile ladder stands and platforms). These requirements apply to mobile ladder stands and platforms in addition to the requirements specified by paragraph (b) of this section that cover all ladders.

Final paragraph (e) is a performance-based revision of the design and use requirements in the existing rule (§ 1910.29(a) and (f)), and consistent with the design requirements in the ANSI standard (A14.7–2011). Therefore, consistent with the requirement in the OSH Act that OSHA express standards "in terms of objective criteria and of the

performance desired," final paragraph (e) does not incorporate the testing requirements in either the existing OSHA rule or ANSI standard (*e.g.*, § 1910.29(f)(5); A14.7–2011 (Section 5)).

For purposes of the final rule, final § 1910.21(b) defines a "mobile ladder stand" as a ladder that:

- Is mobile;
- Has a fixed height;
- Is self-supporting; and
- Is designed for use by one worker at a time.

This paragraph of the final rule also specifies that mobile ladder stands generally consist of:

- Wheels or casters on a rigid base;
- Steps (treads); and
- A top step.

Mobile ladder stands also may have handrails. This definition is consistent with both the existing OSHA rule and ANSI standard (§ 1910.21(g); A14.7–2011, Section 3). Although the final rule does not identify what constitutes a "top step," the ANSI standard defines the term "top step" as "[t]he uppermost flat surface of a ladder stand upon which a person may stand and that has a front to back dimension of not less than 9.5 inches or more than 32 inches and does not exceed 6.7 square feet in area" (A14.7–2011, Section 3).

A "mobile ladder stand platform," as defined in the final rule (§ 1910.21(b)), is a mobile ladder stand with treads leading to one or more platforms. Unlike the definition of mobile ladder stands, some mobile ladder stand platforms may be designed for use by more than one worker at a time.

Although the existing OSHA ladder rules for general industry do not define or specifically address mobile ladder stand platforms, the final definition is consistent with the ANSI standard (A14.7–2011, Section 3). The ANSI standard also defines a "platform" as "[a]n elevated surface for standing or working that is more than 6.7 square feet in area, or more than 32 inches in depth and may be occupied by more than one person" (A14.7–2011, Section 3).

While the existing OSHA rule does not specifically address mobile ladder stand platforms, many of the provisions in the existing rule provide effective worker protection regardless of whether employees are working on mobile ladder stands or mobile ladder stand platforms. Thus, when appropriate, in the final rule OSHA applied provisions in the existing rules to mobile ladder stand platforms as well as mobile ladder stands.

One commenter raised general concerns about the design requirements for mobile ladder stands and platforms:

Nearly all requirements are design and construction requirements over which an employer would have minimal or no control.

Again, an employer would be relying primarily on third party certification without any assurance that such reliance would be recognized as a legitimate defense against OSHA citations (Ex. 368).

The commenter is correct that most of the general provisions in proposed and final paragraph (e)(1) are equipment-design requirements. This also applies to the existing OSHA rules, which have been in place since 1973. Many other OSHA standards also require that employers provide equipment designed, constructed, and maintained so it is safe for their workers to use. In the years since OSHA adopted the existing rules, no employers have raised concerns about being able to comply with the design requirements. OSHA also believes that today, more than 40 years after it adopted the existing rules, virtually all mobile ladder stands and platforms manufactured meet the design requirements of the existing rules, as well as the ANSI standard.

OSHA, however, does not agree that employers have minimal or no control over whether mobile ladder stands and platforms meet the design requirements in the final rule. Employers are free to design and construct their own equipment to the design requirements in OSHA standards, and some employers do. For example, employers may build their own mobile ladder stands and platforms if they need the units for special purposes, or if the ladders must fit into unusual locations.

Employers also have control over the equipment they purchase. They can evaluate, investigate, and even test potential equipment to ensure that it meets OSHA requirements. They also can select equipment that a recognized third party (*e.g.*, Underwriters Laboratories) tests and certifies as meeting the OSHA requirements. In addition, employers can obtain the third-party testing information or reports to reassure themselves that the equipment meets the requirements in the final rule.

Final paragraph (e)(1) establishes general design and use requirements that apply to both mobile ladder stands and mobile ladder stand platforms. OSHA drew these general requirements from two sources: (1) The existing rule (§ 1910.29); and (2) A14.7–2011.

Final paragraph (e)(1)(i), like the existing (§ 1910.29(a)(3)(ii)) and proposed rules, requires that employers ensure that the minimum width of steps on mobile ladder stands and platforms is 16 inches. This minimum-width requirement applies regardless of the

length (depth) of the top step of mobile ladder stands, which, pursuant to A14.7–2011, may be up to 32 inches in depth or 6.7 square feet in area. OSHA believes that this approach is generally consistent with the ANSI standard, which requires that steps, including the top step, on mobile ladder stands have a minimum width of 16 inches (A14.7–2011, Section 4.3.1); for mobile ladder stand platforms, section 4.4.1 of A–14.7–2011 requires a minimum step width of 16 inches.

OSHA believes that employers should not have any problem complying with final paragraph (e)(1)(i). The existing OSHA and ANSI standards have been in place for many years and OSHA believes the width of steps on virtually all mobile ladder stands and platforms meet the ANSI requirements, and, therefore, are in compliance with the final rule. OSHA did not receive any comments on the proposal, and adopts the provision as discussed.

Final paragraph (e)(1)(ii), like the existing (§ 1910.29(a)(3)(iv)) and proposed rules, requires that employers ensure that steps and platforms of mobile ladder stands and platforms be slip resistant. The final rule includes language, drawn from A14.7–2011, that gives employers greater flexibility in complying with the slip-resistance requirement. Final paragraph (e)(1)(ii) provides that employers may meet the slip-resistance requirement by providing mobile ladder stands and platforms where the slip-resistant surfaces either are (1) an integral part of the design and construction of the mobile ladder stand and platform, or (2) provided by a secondary process or operation. For the purposes of this final rule, secondary processes include things such as dimpling, knurling, shotblasting, coating, spraying the walking-working surfaces, or adding durable slip-resistant tape to steps and platforms.

In addition to providing more flexibility than the existing OSHA requirements for meeting the slip-resistance requirement, OSHA believes the final paragraph will help to ensure a level of protection that is equivalent to or greater than the existing requirements. First, it allows employers to select the types of slip resistance that will provide the most effective protection for workers in the particular workplace conditions in which employers use the unit. For example, in outdoor, icy conditions, grated steps and platforms may provide better slip resistance than steps and platforms with a sprayed-on finish.

Second, the new language also indicates that employers have both an initial and continuing obligation to

ensure that steps and platforms on mobile ladder stands and platforms remain slip resistant (*i.e.*, “[t]he steps . . . are slip resistant”). Accordingly, while the manufacturer may apply the secondary slip resistance process initially, if the slip resistance on steps of stands or platforms wears down or is in need of repair, the final rule requires that employers treat those surfaces with additional processes to restore their slip resistance. For example, if slip-resistant tape comes off, the employer must replace it. OSHA believes that employers should not have problems complying with the final provision since slip-resistance processes and materials are readily available in the marketplace. OSHA did not receive any comments on the proposed provision, and adopts it as proposed.

Final paragraphs (e)(1)(iii) and (iv) establish strength and stability requirements for mobile ladder stands and platforms to ensure units are safe for workers to use. Final paragraph (e)(1)(iii), which is almost identical to proposed paragraph (e)(1)(vi), requires that employers ensure mobile ladder stands and platforms are capable of supporting at least four times their maximum intended load. The existing OSHA rule and ANSI standard also require that mobile ladder stands be capable of supporting at least four times the “design working load” or “rated load,” respectively (§ 1910.29(a)(2)(ii)(b); A14.7–2011, Section 4.2.1). Both standards have been in place for many years, so OSHA believes that virtually all mobile ladder stands and platforms manufactured and currently in use already comply with the final rule.

Final paragraph (e)(1)(iv), which also is almost identical to proposed paragraph (e)(1)(iii), requires that employers ensure wheels and casters of mobile ladder stands and platforms under load are capable of supporting: (1) their proportional share of four times the maximum intended load, plus (2) their proportional share of the unit’s weight. OSHA believes this requirement is necessary to ensure that mobile ladder stands and platforms are safe for workers to use. Unless the wheels and casters can support both the proportional weight of the mobile ladder stand or platform and the weight of the maximum intended load placed on that unit, failure of the wheel(s) or caster(s) may occur. If that happens, the stand or platform could become unstable and the worker could fall off the unit and be injured or killed.

Final paragraph (e)(1)(iv) provides greater protection than the existing OSHA rule in § 1910.29(a)(4). The

existing rule does not require that wheels or casters be capable of supporting the weight of the mobile ladder stand or mobile ladder stand platform, as well as the weight of the load (*e.g.*, worker, tools, equipment, and materials) placed on it (§ 1910.29(a)(4)(i)). However, OSHA notes that the final rule is almost identical to the ANSI standard (A14.7–2011, Sections 4.3.7 and 4.4.8). As discussed above, the ANSI standard has been in place for many years, so OSHA believes that virtually all mobile ladder stand and platform wheels and casters manufactured and currently in use already comply with the final rule.

In final paragraphs (e)(1)(iii) and (iv), OSHA replaced the term “design working load” in the existing OSHA rule with “maximum intended load” (*i.e.*, the total load of all employees, equipment, tools, materials, and other loads the employer reasonably anticipates to be applied to the mobile ladder stand or platform). While the definition of “maximum intended load” in this final rule (see § 1910.21(b)) is similar to the definition of “design working load” in the existing rule (see § 1910.21(g)(5)), using the term “maximum intended load” in final paragraphs (e)(1)(iii) and (iv) makes these paragraphs consistent with other provisions in the final rule that use the term.

Finally, consistent with OSHA’s goal to make the final rule performance based, final paragraphs (e)(1)(iii) and (iv) do not incorporate the testing requirements in either the existing OSHA rule (§ 1910.29(f)(5)) or A14.7–2011 (Section 5). OSHA did not receive any comments on either of the proposed requirements, and adopts final paragraphs (e)(1)(iii) and (iv) as discussed above.

Final paragraph (e)(1)(v) establishes general requirements for handrails on mobile ladder stand and platform steps (except for handrails on top steps when paragraph (e)(2)(ii) applies). Final paragraph (e)(1)(v) requires that employers ensure mobile ladder stands and platforms have handrails when the height of the top step or platform is 4 feet or higher above lower levels. Where handrails are required, employers must ensure that the handrails have a vertical height of at least 29.5 inches but not more than 37 inches, as measured from the front edge of the step, unless specified elsewhere in the section.

The purpose of the final paragraph (e)(1)(v) is to protect workers from falling when they are climbing or standing on mobile ladder stands and platforms. OSHA believes handrails are necessary to assist workers as they are

climbing mobile ladder stands and platforms, and also provide a handhold they can grab to steady themselves if they slip or start to fall off the unit. In addition, handrails provide a necessary barrier to prevent workers from falling off the side of steps and off the top step or platform. To ensure that the barrier provides adequate protection, OSHA notes that stands and platforms must have handrails on both sides of the steps, including the top step and platform. On mobile ladder stands, the handrail also must extend across the open back of the top step.

The existing OSHA rule requires that mobile ladder stand steps have handrails (a minimum of 29 inches high, measured vertically from the center of the step) if the height of the top step was more than 5 feet or 5 steps (§ 1910.29(f)(4)). However, the existing rule does not specify the maximum height allowed for the handrails. In addition, the existing rule does not contain a specific provision covering handrails on mobile ladder stand platforms. The proposed rule, on the other hand, included specific and separate handrails provisions for mobile ladder stands and mobile ladder stand platforms (proposed paragraphs (e)(2)(ii) and (e)(3)(ii)). In the final rule, OSHA consolidated those proposed provisions into the general requirement in paragraph (e)(1)(v) to reduce repetition and simplify the final rule.

The final rule provides greater protection than the existing OSHA rule. The final rule requires that mobile ladder stands and platforms have handrails where the top step height is at least 4 feet compared to more than 5 feet or 5 steps in the existing rule. OSHA notes that the ANSI standard (A14.7–2011, Sections 4.3.5 and 4.4.5) also requires that handrails provide the same level of protection as the final rule.

Final paragraph (e)(1)(v), like the proposal (a note to proposed paragraphs (e)(2)(ii) and (e)(3)(ii)), also allows alternatives to the handrails requirement for “special-use applications.” In such situations, the final rule permits employers to use removable gates or non-rigid members (such as chains) instead of handrails on the top step of mobile ladder stands and platforms. The alternative means of compliance allows employers to remove the gates or chains when a work task involves special-use application; however, employers must replace the gates or chains (*i.e.*, comply with the handrail requirement) when they complete the special-use task. In a special use application, it is important that the mobile ladder stand or platform is placed to minimize the risk of falls.

For example, when a gate needs to be removed to place or remove objects from a shelf, the employer needs to ensure that the unit is placed so there is no gap between the unit and shelf that could result in a worker falling while performing the task. OSHA believes this alternative method provides flexibility for employers while reducing the exposure of workers to fall hazards under these conditions. For the purposes of this provision, a special-use application may include a situation in which permanent handrails block or impede the movement of boxes, products, or materials from the ladder stand or platform to shelves or other storage areas. The ANSI standard also includes this alternative method (A14.7–2011, Sections 4.3.5, 4.3.6, 4.4.5, and 4.4.6). OSHA did not receive any comments on the proposed provisions, and adopts them as consolidated and revised.

Final paragraph (e)(1)(vi), like the existing OSHA and proposed rules (§ 1910.29(a)(3)(i) and (f)(2); proposed paragraph (e)(1)(v)), requires that employers ensure the maximum work-surface height of mobile ladder stands and platforms does not exceed four times the shortest dimension of the base, without additional support. OSHA believes this requirement is necessary to prevent units from tipping over and injuring workers. Also consistent with the existing and proposed rules, the final rule specifies that when mobile ladder stands and platforms need to reach greater heights, the employer must provide additional support such as outriggers, counterweights, or comparable means to stabilize the base and prevent the unit from overturning. The ANSI standard includes the same requirement (A14.7–2011, Section 5.2).

Final paragraph (e)(1)(vi) differs from the existing OSHA rule in one respect: it does not incorporate the testing requirement in existing § 1910.29(f)(2) for calculating the maximum base length, opting instead to adopt a performance-based requirement. Similarly, it does not incorporate the A14.7–2011 testing provisions. OSHA did not receive any comments on the proposal, and adopts it with minor editorial clarifications.

Final paragraph (e)(1)(vii), like proposed paragraph (e)(1)(iv), requires that employers ensure wheels and casters on mobile ladder stands and platforms are equipped with a system that will impede horizontal movement when a worker is on the unit. OSHA drew the final requirement from the ANSI standard (A14.7–2011, Sections 4.3.8 and 4.4.9); the existing OSHA rule does not contain a similar provision.

OSHA believes the requirement in final paragraph (e)(1)(vii) is necessary to prevent accidental or inadvertent movement of a mobile ladder stand or platform. If the stand or platform suddenly moves, it may cause the worker to fall off the unit. Sudden movement also can cause materials, equipment, and tools to fall off a mobile ladder stand or platform and hit employees working in the immediate area. The phrase “rigid and swivel” has been removed from the proposed language because it is unnecessary. In addition, OSHA added the phrase “when an employee is on a stand or platform” to the proposed text to clarify that it is acceptable that mobile ladder stands move at other times. OSHA did not receive any comments on the proposed rule, and adopts it as discussed.

Final paragraph (e)(1)(viii), like proposed paragraph (e)(1)(vii), requires that employers ensure mobile ladder stands and platforms do not move while workers are on them. The final rule will prevent workers from falling from mobile ladder stands and platforms. Working on a unit, particularly on the top step or platform, raises the unit’s center of gravity, causing the unit to become less stable. If somebody moves the unit, intentionally or not, a worker on the unit could lose his or her balance and experience a serious fall. The same consequences could occur if a worker rides on a mobile ladder stand or platform when somebody moves the unit to a new location in the workplace.

OSHA also drew this requirement from A14.7–2011 (Section 6.4) because the existing rule does not contain a similar requirement. OSHA did not receive any comments on the proposed rule, and adopted it as proposed with minor editorial changes for clarity.

Final paragraph (e)(2) establishes design requirements for mobile ladder stands that apply to mobile ladder stands in addition to the general mobile ladder stand and platform requirements in final paragraph (e)(1). As with the general requirements in final paragraph (e)(1), OSHA carried forward most of the provisions in final paragraph (e)(2) from its existing rule (§ 1910.29) or from A14.7–2011.

Final paragraph (e)(2)(i), like proposed paragraph (e)(2)(i), establishes requirements for mobile ladder stand steps. The employer must ensure that these steps:

- Are uniformly spaced and arranged;
- Have a maximum rise of 10 inches; and
- Have a minimum depth of 7 inches.

The final rule also requires that the employer ensure the slope (angle) of the

“step stringer” to which the steps are attached is not more than 60 degrees from horizontal. A step stringer (also called a “stile” or “siderail”) is the inclined structural member that supports the steps (treads).

The requirements in final paragraph (e)(2)(i) are consistent with the general requirements for ladders in final paragraph (b) of this section. Final paragraph (b) also requires that ladder steps be “parallel, level, and uniformly spaced” (final paragraph (b)(1)) and have steps spaced “not less than 10 inches and not more than 14 inches apart” (final paragraph (b)(2)) (see discussion of final paragraph (b) above).

Final paragraph (e)(2)(i) differs from the existing OSHA rule (§ 1910.29(f)(3)) in two respects. The final rule does not carry forward the existing requirements to have (1) a 9-inch minimum rise for mobile ladder stand steps, and (2) a minimum 55-degree slope for step stringers. OSHA believes final paragraph (e)(2)(i) simplifies the rule and provides greater compliance flexibility. Since the final rule is virtually identical to the ANSI standard (A14.7–2011, Section 4.3.3), OSHA also believes the revisions to the final rule do not compromise worker protection. OSHA did not receive any comments on the proposed rule, and adopted it with minor editorial revisions.

Final paragraph (e)(2)(ii), like proposed paragraph (e)(2)(iii) and the ANSI standard (A14.7–2011, Section 4.3.6), establishes requirements for mobile ladder stands with a top step height more than 10 feet above lower levels. Final paragraph (e)(2)(ii) requires that employers ensure these mobile ladder stands have handrails on three sides of the top step. The employer must ensure that the handrail has a vertical height of at least 36 inches. Also, top steps with a length (depth) of at least 20 inches, front to back, must have midrails and toeboards.

The requirements in final paragraph (e)(2)(ii) provide additional protection from falls and falling objects that are particularly important when employees work on taller mobile ladder stands. To protect workers from falls, final paragraph (e)(2)(ii) ensures that workers have a handhold to grab onto while they are climbing or located on the top step. In addition, final paragraph (e)(2)(ii) requires top steps that are at least 20 inches in depth to be provided with a midrail and toeboard. This protects adjacent workers from falling objects when the top step becomes large enough for the possibility of materials, tools, equipment, or other objects to be placed on the top step. OSHA drew the requirements in final paragraph (e)(2)(ii)

from the ANSI standard (A14.7–2011, Section 4.3.6). The existing OSHA rule (§ 1910.29(f)(4)) does not include any of these protections.

Although final paragraph (e)(2)(ii) is similar to proposed paragraph (e)(2)(iii), it also differs in some respects. OSHA reorganized the final paragraph so it is a plain-language provision. OSHA believes that the reorganized provision in the final rule is easier for employers to understand than the proposed provision.

Also, final paragraph (e)(2)(ii) contains two clarifications of the proposed provision. First, final (e)(2)(ii) clarifies the handrail, midrail, and toeboard requirements, stating that employers must provide these protective structures on three sides of the top step. Although OSHA believes that most employers understand that locating handrails, midrails, and toeboards on three sides is necessary to provide adequate protection to their workers, the final rule expressly clarifies this requirement.

Second, a note to final paragraph (e)(2)(ii), like final paragraph (e)(1)(v), incorporates an alternative method from the handrail and midrail requirement for special-use applications. (See the explanation of the exception for special-use applications in paragraph (e)(i)(v) above.) OSHA did not receive any comments on the proposed provision, and adopts it as revised.

Final paragraph (e)(2)(iii), like proposed paragraph (e)(2)(iv), requires that employers ensure the standing areas of mobile ladder stands are within the base frame. OSHA believes this requirement is necessary to ensure the stability of mobile ladder stands. Keeping the center of gravity within the base frame increases the stability of the mobile ladder stand. This requirement reduces the potential for the mobile ladder stand to tip when a worker is using it.

OSHA drew final paragraph (e)(2)(iii) from the ANSI standard (A14.7–2011, Section 4.3.9) since the existing OSHA rule does not include this requirement. Consistent with the goal of making the final rule more performance based, OSHA did not adopt the stability-testing requirements in the ANSI rule (A14.7–2011, Section 5). OSHA did not receive any comments on the proposed provision, and adopts it as proposed.

Employers must comply with the design requirements for mobile ladder stand platforms specified by final paragraph (e)(3), as well as the general requirements for mobile ladder stands and platforms in final paragraph (e)(1). OSHA drew most of these requirements from A14.7–2011. In addition, OSHA

expanded the existing requirements on mobile ladder stands in § 1910.29 that apply to mobile ladder stand platforms.

Final paragraph (e)(3)(i), like the proposed paragraph and final paragraph (e)(2)(i), requires that employers ensure the steps of mobile ladder stand platforms:

- Are uniformly spaced and arranged;
- Have a maximum rise of 10 inches; and
- Have a minimum depth of 7 inches.

The final rule also requires that the employer ensure the slope (angle) of the “step stringer” to which the steps are attached is not more than 60 degrees from horizontal.

Final paragraph (e)(3)(i) differs from final paragraph (e)(2)(i) in one respect. It includes an exception when the employer demonstrates that the final requirement is not feasible. In that circumstance, the employer may use mobile ladder stand platforms that have steeper slopes or vertical rung ladders, provided the employer stabilizes the alternative unit to prevent it from overturning. The final rule includes this exception because OSHA recognizes that there may be situations or locations where, for example, the slope of the step stringer on a mobile ladder stand platform may need to be greater than the 60-degree limit. To illustrate, there may be a workplace space where the employer needs to use a mobile ladder stand platform, but the unit does not fit. In that situation, OSHA believes it would be appropriate to use an alternative unit with a steeper stringer slope or a vertical rung ladder that takes up less space.

The ANSI standard also includes a similar exception for mobile ladder stand platforms (A14.7–2011, Section 4.4.3). The exception in the ANSI standard specifically permits employers to use alternative mobile ladder stand platforms that have steps with a slope of 60 to 70 degrees. OSHA notes that some alternative units consist of retractable ship’s stairs which, consistent with final § 1910.25(e)(1), have a slope of 60 to 70 degrees. When employers demonstrate the final rule is not feasible, OSHA notes that employers will be in compliance with final paragraph (e)(3)(i) if they use mobile ladder stand platforms with a slope of up to 70 degrees, the limit permitted by A14.7–2011, Section 4.4.3. The exception also requires that employers properly stabilize the alternative unit to reduce the risk of workers falling off the steeper steps. OSHA did not receive any comments on the proposed provision, and adopts it as discussed above.

Final paragraphs (e)(3)(ii) and (iii) establish requirements addressing the

platform area of mobile ladder stand platforms. When the height of the platform is 4 feet to 10 feet, final paragraph (e)(3)(ii) requires that employers ensure the platform areas have handrails and midrails. Employers also must ensure the handrails on the platforms in this height range have a vertical height of at least 36 inches. As discussed in final paragraph (e)(2)(ii), these requirements are necessary to protect workers from falling off walking-working surfaces that are 4 feet or more above a lower level.

Although the existing OSHA rule contains a requirement for handrails on mobile ladder stands (§ 1910.29(f)(4)), it only requires that the vertical of height of the handrails be at least 29 inches, which is not as protective as the ANSI standard. Therefore, OSHA adopted final paragraph (e)(3)(ii) from the ANSI standard (A14.7–2011, Section 4.4.4).

Final paragraph (e)(3)(ii) differs from the proposed rule in that OSHA removed the proposed requirement that mobile ladder stand platforms have handrails on the steps if the top step height is 4 feet to 10 feet. The final rule consolidated that requirement in final paragraph (e)(1)(v), which preserves the step-handrail requirement for both mobile ladder stands and platforms. (See discussion of handrails in the summary of final paragraph (e)(1)(v) above.) OSHA did not receive any comments on the proposed requirement, and adopts it as revised.

Final paragraph (e)(3)(iii), like the proposal (proposed paragraph (e)(3)(iii)), establishes requirements for mobile ladder stand platforms that are more than 10 feet above a lower level. For these units, the final rule requires that employers must ensure that the exposed sides and ends of the platforms have both guardrails and toeboards. OSHA notes that all fall protection and falling object protection requirements must meet the systems criteria in final § 1910.29.

OSHA believes it is essential that guardrails on platforms that are more than 10 feet in height comply with the criteria in final § 1910.29(b) to ensure that employers adequately protect workers from falling off the platforms. OSHA also believes that toeboards must meet the criteria in final § 1910.29(k)(1) to ensure workers on the ground are not hit by falling objects. The toeboards must, consistent with the requirements of § 1910.29:

- Have a vertical height of at least 3.5 inches;
- Not have more than a 0.25-inch clearance above the platform surface;

- Be solid or have openings that do not exceed 1-inch at the greatest dimension; and
- Be capable of withstanding a force of at least 50 pounds applied at any downward or outward direction at any point along the toeboard (see final § 1910.29(k)(1)(ii)).

Lastly, like final paragraphs (e)(1)(v) and (e)(2)(ii), final paragraph (e)(3)(iv) includes language, proposed as a note to this provision, that permits the use of removable gates or non-rigid members instead of handrails and guardrails in special-use applications (see further discussion of special-use applications in final paragraph (e)(1)(v) above). OSHA did not receive any comments on the proposed provisions, and adopts them as revised.

Section 1910.24—Step Bolts and Manhole Steps

Final § 1910.24, like the proposed rule, establishes new design, strength, and use requirements for step bolts and manhole steps. The final rule defines a step bolt as “a bolt or rung attached at intervals along a structural member used for foot placement and as a handhold when climbing or standing” (§ 1910.21(b)). Step bolts, often are used on metal poles or towers, and include pole-steps, commonly used on wooden poles such as utility poles.

The final rule, like the proposed rule, defines manhole steps as “steps individually attached to, or set into, the wall of a manhole structure” (§ 1910.21(b)). Manhole steps are cast, mortared, or attached by mechanical means into the walls of the base, riser, and conical top sections of a manhole.

Telecommunications, gas, and electric utility industries are the industries that most often use step bolts and manhole steps. Manufacturing establishments also use them instead of conventional ladders and stairs, especially in locations where it is infeasible to use ladders and stairs.

OSHA drew the step bolt and manhole step requirements in the final rule from the following six sources:

- The step bolt, pole step, and manhole ladder requirements in OSHA’s Telecommunications standard (29 CFR 1910.268);
- The step bolt and manhole step provisions in OSHA’s 1990 proposed Walking and Working Surfaces and Personal Protective Equipment (Fall Protection Systems) standard (55 FR 13360), which drew its requirements from proposed Electric Power Generation, Transmission, and Distribution standard (29 CFR 1910.269) (54 FR 4974 (1/31/1989));

- American National Standards Institute/Telecommunications Industry Association (ANSI/TIA) 222–G–1996, Structural Standard for Antenna Supporting Structures and Antennas (ANSI/TIA 222–G–1996) (Ex. 33);

- American National Standards Institute/Telecommunications Industry Association (ANSI/TIA) 222–G–2005, Structural Standard for Antenna Supporting Structures and Antennas (ANSI/TIA 222–G–2005) (Ex. 27);

- American Society for Testing and Materials (ASTM) C 478–13, Standard Specification for Precast Reinforced Concrete Manhole Sections (ASTM C 478–13) (Ex. 381); and

- American Society for Testing and Materials (ASTM) A 394–08, Standard Specification for Steel Transmission Tower Bolts, Zinc-Coated and Bare (ASTM A 394–08).

The requirements in final § 1910.24 replace the step bolt, pole step, and manhole step provisions in the existing Telecommunications standard (§ 1910.268(h)), and final § 1910.23 replaces the ladder requirements in § 1910.268(h). Thus, the final rule deletes those requirements from § 1910.268(h). Therefore, the telecommunications industry, as well as all other users of ladders, step bolts, and manhole steps in general industry must comply with the ladder, step bolt, and manhole step requirements in revised subpart D.

Consistent with section 6(b)(5) of the OSH Act (29 U.S.C. 655(b)(5)), the final rule is performance based to the extent possible. For example, final paragraph (a)(2) of this section requires that the employer ensure that step bolts are designed, constructed, and maintained to prevent the worker’s foot from slipping off the ends, instead of mandating specific requirements on the size and shape that the step bolt heads must meet.

OSHA notes that two of the step bolt provisions (final paragraphs (a)(1) and (7)), and all but two of the manhole step requirements (final paragraph (b)(2)), apply only to those steps installed after the effective date of the final rule. OSHA recognizes that many step bolts and manhole steps already in workplaces currently comply with the requirements in final § 1910.24. This high rate of compliance, OSHA believes, is the result of the Agency issuing its Telecommunications standard in 1975 (40 FR 13341 (3/26/1975)), and because the national consensus standards addressing step bolts and manhole steps have been in place for a number of years. That said, OSHA believes the most efficient and least disruptive way

to implement the final rule is to require employers to comply with the final rule when they install new step bolts and manhole steps. Employers may install new step bolts and manhole steps when they install new structures (e.g., telecommunications and utility towers), or when they replace damaged step bolts and manhole steps (e.g., broken, missing) that are hazardous for workers to use. Because final paragraphs (a)(8) and (b)(3) of this section require that employers inspect step bolts and manhole steps, respectively, at the start of each work shift, OSHA believes that employers will quickly and readily identify whether hazardous conditions, including damage, are present. If such conditions are present, final § 1910.22(d)(2) and (3) require that employers repair, correct, or replace the step bolts or manhole steps.

For example, if an inspection of an electric utility tower finds a corroded step bolt that cannot support the required load (final paragraphs (a)(6) and (7)), the final rule requires that the employer replace it with one made of corrosion-resistant materials or with corrosion-resistant coatings (final paragraph (a)(1)). However, if the inspection shows existing step bolts still have useful life, *i.e.*, they can support the required load and meet the other requirements in final paragraph (a), the employer can continue to use the step bolt even if it is not made with corrosion-resistant materials or coatings. OSHA believes that following this type of implementation strategy and schedule, rather than requiring employers to retrofit all existing step bolts not made with corrosion-resistant materials or coatings, will ensure that the final rule does not impose an undue burden on employers, while ensuring that the existing step bolts are safe for workers to use.

Paragraph (a)—Step Bolts

Paragraph (a) of the final rule, like the proposal, establishes requirements addressing the design, dimensions, strength, and installation of step bolts. OSHA received a comment recommending that the final rule prohibit the use of step bolts unless it requires that employers provide fall protection, such as ladder safety systems, when workers use step bolts (Ex. 155). Dr. J. Nigel Ellis, of Ellis Fall Safety Solutions, referenced a 1990 Duke Power study he said demonstrated step bolts had a high breaking frequency, and therefore, that fall protection was necessary for workers using step bolts. Dr. Ellis also said fall protection needed to be continuous, and

not require the worker to manipulate or handle objects when climbing.

OSHA addressed in final § 1910.28 Dr. Ellis' concerns about protecting workers using step bolts that break unexpectedly. That section requires that employers provide fall protection for workers on any walking-working surface with an unprotected side or edge that is four feet or more above a lower level (§ 1910.28(b)). The final rule is more protective than ANSI/TIA 222-G-2005, which requires that antenna-supporting structures designed for climbing to heights greater than 10 feet must have at least one climbing facility (e.g., step bolts) and a "safety climb device" (Section 12.3). The ANSI/TIA 222-G-2005 standard defines a "safety climb device" as "a support system that may be a cable or solid rail attached to the structure" (Section 12.2), and specifies that the device meet the requirements in the A14.3 standard (Section 12.4).

Final paragraph (a)(1), like the proposed rule, requires that employers ensure step bolts installed in an environment where corrosion may occur are constructed of, or coated with, material that protects against corrosion. The final rule is consistent with 1990 proposed § 1910.24(b)(6) (55 FR 13399). The ANSI/TIA 222-G-2005 standard requires that structural steel members and components must have zinc coating (Section 5.6.1). Although the national consensus standard specifies that hot-dip galvanizing is the preferred method, employers may use other equivalent methods (Section 5.6.1).

Corrosive environments can cause damage to unprotected metals. For example, corrosion can lead to deterioration and weakening that may cause step bolts to break or fail to support the total required load. OSHA believes that corrosion-resistant materials and coatings will protect step bolts and ensure they are capable of supporting at least four times the maximum intended load.

Final paragraph (a)(1), like the proposed rule, applies the requirement prospectively to step bolts installed on or after the effective date of the final rule. As noted above, OSHA believes this is the most efficient way to implement this provision while, at the same time, ensuring worker protection. Mr. Robert Miller, of Ameren Corporation, supported OSHA's decision to make the paragraph (a)(1) prospective (Ex. 189). Accordingly, OSHA is adopting paragraph (a)(1) as discussed.

Final paragraph (a)(2), similar to the proposed rule, requires that employers ensure step bolts are designed, constructed, and maintained to prevent

the worker's foot from slipping off the end of it. If a worker's foot slips off the end of the step bolt, the worker could fall or sustain an injury from slipping. Designing the head of the step bolt to prevent the worker's foot from slipping off will provide the requisite protection. Final paragraph (a)(2) also is consistent with the ANSI/TIA 222-G-2005 standard (Section 12.5(f)), as well as 1990 proposed § 1910.24(b)(5).

The proposed rule specified that step bolts be "designed to prevent slipping or sliding off the end of the bolt," but the proposal also required step bolts to be "designed, constructed, and maintained" free of recognized hazards (proposed § 1910.22(a)(3)). Only properly designed, constructed, and maintained step bolts will be effective in preventing the worker's foot from slipping off the end, therefore the Agency added "constructed and maintained" to final paragraph (a)(2) to emphasize that step bolts must meet these requirements as well. OSHA did not receive any comments on the proposed provision and has adopted paragraph (a)(2) with the revisions discussed.

Final paragraph (a)(3), like the proposed rule, requires that employers ensure step bolts are uniformly spaced at a vertical distance of not less than 12 inches and not more than 18 inches apart, measured center to center. The final paragraph also notes that the spacing from the entry and exit surface to the first step bolt may differ from the spacing between other step bolts. This requirement means that the maximum uniform spacing between alternating step bolts is 18 inches, resulting in a maximum spacing between step bolts on the same side of 36 inches. OSHA believes that uniform spacing helps to ensure safe climbing when using step bolts. (Figure D-6 illustrates the vertical spacing requirements in the final rule.)

The final rule generally is consistent with the proposed rule and the existing Telecommunications standard (§ 1910.268(h)(2)), which limit the maximum vertical spacing between step bolts (alternating) to 18 inches. OSHA adopted the Telecommunications standard in 1975 based on recommendations of a voluntary committee of representatives from telephone companies and communication unions (40 FR 13341 (3/26/1975)). The 1990 proposal specified that the spacing between step bolts be between 6 and 18 inches (§ 1910.24(b)(1)). The ANSI/TIA 222-G-2005 standard requires that the spacing between step bolts be between 10 to 16 inches, with a tolerance of ± 1 inch (Section 12.5).

In the proposed rule, OSHA requested, but did not receive, comments on whether the Agency should adopt the proposed requirement or the spacing that the ANSI/TIA 222-G-2005 standard specifies. OSHA believes that adopting the maximum 18-inch uniform vertical spacing requirement in final paragraph (a)(3) is appropriate for two reasons. First, as mentioned earlier, the step bolt requirement in the Telecommunications standard has been in place for more than 35 years. During that period, the telecommunications industry constructed many towers that have step bolts spaced no more than 18 inches apart. OSHA has no data showing that the maximum 18-inch vertical step bolt spacing requirement in the Telecommunications standard poses any safety problems or resulted in any injury in that industry. Moreover, OSHA believes that most of the telecommunications industry already is in compliance with § 1910.268, and that final paragraph (a)(3) would not impose a financial burden on employers.

Second, if the ± 1 -inch tolerance allowed in the ANSI/TIA 222-G-2005 standard is taken into account, there is, at most, only a 1-inch difference in the maximum vertical spacing in final paragraph (a)(3) and the ANSI/TIA 222-G-2005 standard. OSHA does not consider this difference to be significant in this provision. Therefore, OSHA is adopting in the final provision, the step bolt spacing requirement (between 12 and 18 inches) that is consistent with OSHA's Telecommunications standard.

Final paragraph (a)(3), like the proposed rule, allows the spacing of step bolts at the entry and exit surface to the first step bolt to differ from the uniform spacing between the other step bolts. For example, the first step bolt on a monopole may be 10 feet above the ground. Having a higher first step bolt on a structure is not unusual; in many cases, this configuration limits unauthorized access to the structure's hazardous heights, communication devices, or electrical wiring.

OSHA's Telecommunications standard also allows the spacing of the initial step bolt to differ from the other steps, "except where working, standing, or access steps are required" (existing § 1910.268(h)(2)). The 1990 proposal did not specifically address spacing of the initial step bolt. Section 12.5(a) of ANSI/TIA 222-G-2005 requires that "spacing shall remain uniform over a continuous length of climb," but does not address entry and exit spacing. OSHA believes that allowing a variation in spacing from the entry surface to the first step bolt or from the last step bolt

to the exit surface will make it easier and safer for workers to establish their foothold. Once again, since the Telecommunication standard allows the spacing on the first and exit step bolt to differ and OSHA is not aware of any injuries or problems occurring as a result, the Agency is adopting paragraph (a)(3) as proposed, with minor editorial revisions.

Final paragraph (a)(4), like the proposed rule, requires that employers ensure step bolts have a minimum clear width of 4.5 inches. The final rule is the same as OSHA's Telecommunications standard (§ 1910.268(h)(2)); 1990 proposed § 1910.24(b)(2); and the ANSI/TIA 222-G (2005) standard (Section 12.5(f)).

OSHA believes it is necessary that workers have an adequate space on which to step and secure their foothold while climbing or they could slip and fall. OSHA believes the telecommunications industry supports the 4.5-inch minimum clear-step width in the Telecommunications and ANSI/TIA 222-G-2005 standards. In addition, since both standards have been in place for many years, OSHA believes the industry already is in compliance with the minimum clear width requirement.

Mr. Larry Halprin, of Keller and Heckman, said that OSHA should only apply the vertical spacing distance (final paragraph (a)(3)) and minimum clear width (final paragraph (a)(4)) requirements prospectively (Ex. OSHA-S029-2006-0662-0381). He stated that, in the OSHA notice reopening the rulemaking docket on subpart D, the Agency said that the 1990 proposal specified prospective application of the revised provisions, and "would allow workplaces and equipment meeting existing subpart D requirements to be 'grandfathered in'" (68 FR 23529 (5/2/2003)). However, neither the 2010 nor the 1990 proposed rules stated that OSHA would apply the vertical spacing or minimum clear width requirements prospectively. In addition, as mentioned, the Telecommunications and ANSI/TIA 222-G-2005 standards, which have been in place more than 35 years, include both requirements. Moreover, OSHA received no comments from affected industries indicating that they could not meet the existing vertical spacing and minimum clear width requirements. Therefore, OSHA believes that most employers already are in compliance with final paragraphs (a)(3) and (4). Accordingly, OSHA does not believe it is necessary to limit the vertical spacing and minimum clear width requirements to prospective application and adopts the provisions as

proposed, with minor editorial revisions.

Final paragraph (a)(5), like the 2010 and 1990 proposed rules, requires that employers ensure the minimum perpendicular distance between the centerline of each step bolt to the nearest permanent object in back of the step bolt is at least 7 inches. When employers can demonstrate that they cannot avoid an obstruction, the final rule permits them to reduce the minimum perpendicular clearance space to 4.5 inches.

The required 7-inch minimum perpendicular clearance space in final paragraph (a)(5) is consistent with the minimum perpendicular clearance for fixed ladders in final § 1910.23(d)(2), the construction ladders standard (§ 1926.1053(a)(13)), and ANSI/TIA 222-G-2005 standard (Section 12.5). However, final paragraph (a)(5), like the 2010 and 1990 proposals, provides more flexibility than those standards. When the employer demonstrates that an obstruction is not avoidable, final paragraph (a)(5) allows employers to reduce the minimum perpendicular clearance to 4.5 inches for any step bolt.

OSHA believes that a 7-inch minimum perpendicular clearance for step bolts, like fixed ladders, is necessary to ensure workers are able to maintain a secure foothold and negotiate the step bolts while they are climbing or working. Because the final rule gives employers the flexibility to reduce the minimum perpendicular clearance space for any step bolt if an obstruction cannot be avoided, the Agency believes that employers need to be able to demonstrate that they made a case-by-case evaluation and determination that the obstruction was not avoidable in the specific instance. For example, where an employer uses step bolts in an industrial setting because it is not feasible to use fixed ladders or stairs (e.g., space limits), employers need to show they evaluated the specific situation and considered potential options in determining whether they could avoid or remove the obstruction. The language in the final rule clarifies the Agency's intent about the situations in which employers may reduce the minimum perpendicular clearance space on a step bolt. The Agency did not receive comments on proposed paragraph (a)(5) and adopts the requirement as discussed.

Final paragraphs (a)(6) and (7) address strength requirements for existing step bolts and for step bolts installed on or after the effective date of the final rule. The final rule establishes different strength requirements for existing and new step bolts to reduce the need for

retrofitting step bolts that currently meet the maximum intended load requirements in final § 1910.22(b) and still have useful life.

Final paragraph (a)(6), like the proposed rule, requires that employers ensure each step bolt installed before the effective date of the final rule is capable of supporting the maximum intended load. The final rule defines maximum intended load as “the total load (weight and force) of all workers, equipment, vehicles, tools, materials, and loads the employer reasonably anticipates to be applied to a walking-working surface at any one time” (§ 1910.21(b)).

The final provision is based on the Telecommunications standard requirement that employers shall ensure that no employee nor any material or equipment may be supported or permitted to be supported on any portion of a ladder unless it is first determined, by inspections and checks conducted by a competent person that such ladder is adequately strong, and in good condition (§ 1910.268(h)(1)), and is consistent with 1990 proposed § 1910.24(c)(2). The ANSI/TIA 222–G–2005 standard establishes strength specifications:

A load factor, $\alpha_L = 1.5$, shall be applied to the nominal loads specified herein:

The minimum nominal load on individual rungs or steps shall be equal to a normal concentrated load of 250 lbs [1.1 kN] applied at the worst-case location and direction.

The minimum nominal load on ladders shall be 500 lbs [2.2 kN] vertical and 100 lbs [445 N] horizontal applied simultaneously, concentrated at the worst-case location between consecutive attachment points to the structure (Section 12.4).

The general requirements in the final rule specify that employers ensure all walking-working surfaces are capable of supporting the total weight and force employers reasonably anticipate placing on that surface (§ 1910.22(b)). Final paragraph (a)(6) reinforces that this requirement applies as well to existing step bolts. OSHA believes step bolts that cannot support their maximum intended load are not safe to use, regardless of when the employer installed them.

The ANSI/TIA 222–G standard has been in place since 2005, and OSHA believes most step bolts manufactured today meet the requirements of that standard. In addition, OSHA’s experience is step bolt manufacturers generally specify maximum loads that step bolts can withstand without failure. As such, OSHA believes that most existing step bolts are in compliance with final paragraph (a)(6) and § 1910.22(b). That said, employers must

continue to inspect step bolts to ensure that the loads placed on the step bolts covered by this provision do not exceed the maximum intended loads and manufacturer specifications. This is because failure or deflection of step bolts can occur during use, particularly since the weight on step bolts is not static and varies as a worker climbs. OSHA did not receive any comments on proposed paragraph (a)(6), and is adopting it as discussed.

Final paragraph (a)(7), like the proposed rule, requires that employers ensure each step bolt installed on or after the effective date of the final rule is capable of supporting at least four times its maximum intended load. As discussed in the proposed rule, OSHA believes that requiring step bolts be capable of supporting four times the maximum intended load is necessary to provide a safety factor that is adequate to ensure that step bolts do not fail during use. The required safety factor (*i.e.*, 4 times the maximum intended load) will provide an additional level of assurance that step bolt are safe for workers to use. OSHA believes that common engineering practice requires manufacturers to include a safety factor in any product design to account for any unanticipated conditions that may stress the product beyond its designed capabilities.

Final paragraph (a)(7) is consistent with 1990 proposed § 1910.24(c)(1), which specified that “[e]ach step bolt shall be capable of withstanding, without failure, at least four times the intended load calculated to be applied to the [step] bolt.” In addition, as mentioned above, the Telecommunications standard requires any portion of a ladder to be “adequately strong,” while the ANSI/TIA 222–G–2005 standard establishes specification requirements.

The ASTM A 394–08 standard establishes specification for step bolts with nominal thread diameters of 1/2, 5/8, 3/4, 7/8 and 1-inch (Ex. 383). OSHA believes that 5/8-inch diameter steel step bolts normally comply with the strength requirement in final paragraph (a)(7), and are the most commonly used step bolts in general industry. Manufacturers also produce step bolts smaller than 5/8-inch diameter, but OSHA notes that 1/2-inch step bolts may not comply with final paragraph (a)(7).

Final paragraph (a)(7), unlike the ANSI/TIA and ASTM standards, is a performance-based requirement. OSHA believes that giving employers flexibility in determining the maximum load they anticipate applying to any step bolt will ensure that the maximum intended load accurately reflects the

particular work and workplace conditions present. By contrast, OSHA believes that the ANSI/TIA 222–G–2005 test procedures are for manufacturers, not employers, because manufacturers are in the best position to test whether step bolts meet the strength requirements. Employers are free to use the specifications and test procedures in the ANSI/TIA national consensus standard to determine whether their step bolts meet the maximum intended load requirements in final paragraph (a)(7).

OSHA received two comments on the proposed requirement. As discussed in final paragraph (a)(1), Mr. Miller, of Ameren, supported the Agency’s decision to apply the new strength requirement in final paragraph (a)(7) prospectively (Ex. 189). In the second comment, Mr. Richard Willis, of Southern Company, questioned how employers would calculate the performance-based maximum intended load for step bolts in final paragraph (a)(7) (Ex. 192). He recommended:

We suggest that the methodology of National Electric Safety Code (NEC) 2007 Rule 261N be adopted. We also feel that OSHA needs to state a failure criteria for 1910.24(a)(7). . . .

Instead of using the four times the maximum intended load, OSHA should consider using the criteria of the NESC or IEEE 1307 (Ex. 192).

OSHA recognizes the methodologies in the national consensus standards that Mr. Willis recommended are methodologies employers can use to determine and ensure that step bolts are capable of supporting four times the maximum intended load. Employers are free to use the NESC and IEEE 1307 standards, which OSHA referenced in the proposed rule (75 FR 28901) in determining whether their step bolts are capable of supporting four times the total load they reasonably anticipate placing on the step bolt. In a 2003 letter of interpretation, OSHA wrote, “We believe in most situations an employer’s compliance with IEEE 1307–1996 will usually prevent or eliminate serious hazards” (OSHA letter to Mr. Brian Lacoursiere, May 5, 2003).²¹

Under the performance based final rule, employers may use other methods to ensure step bolts comply with the strength requirement in final paragraph (a)(7). For example, employers may select step bolts that manufacturers test according to the strength requirements specified by the ANSI/TIA 222–G

²¹ Available from OSHA’s website at: http://www.osha.gov/pls/oshaweb/owadisp.show_document?p_table=INTERPRETATIONS&p_id=24564.

standard (Section 12.4), and then ensure that workers do not place a total load on the step bolts that exceeds the specified strength limits.

Mr. Willis also said that OSHA should state the failure criteria for final paragraph (a)(7) as: "If the intent is a 15 degree deflection as referenced by the NESC and in 1910.24(a)(9), then this should be stated" (Ex. 192). OSHA does not believe it is necessary to put additional language in final paragraph (a)(7) specifying a "failure criteria" for step bolt strength. First, the Agency believes that final paragraph (a)(9) makes clear that step bolts bent more than 15 degrees do not meet the requirement in paragraph (a)(7). Final paragraph (a)(9) states that employers must remove and replace those step bolts. Second, the language Mr. Willis recommended is not performance based as it does not include other failure criteria manufacturers and employers may use. Therefore, OSHA finalizes the provision as discussed.

Final paragraph (a)(8) requires that employers ensure step bolts are inspected at the start of each work shift and maintained in accordance with § 1910.22. By including the reference to § 1910.22, OSHA is emphasizing that step bolts, like all walking-working surfaces, must meet the general requirements in the final rule.

OSHA believes a visual inspection often can reveal structural and other problems with step bolts that may make them unsafe for workers to use. Employers must correct, repair, or replace step bolts with structural problems (e.g., broken, fractured, loose, bent, or corroded step bolts) that indicate that the step bolts cannot support the maximum intended load (final § 1910.22(b) and (d)(2)). A visual inspection also can identify whether step bolts are dry, or likely to be slippery because of snow, ice, or rain (final § 1910.22(a)(2)). Final paragraph (a)(8) requires that employers address these conditions to maintain step bolts in accordance with § 1910.22.

As with the inspection requirements in final § 1910.22, the inspection of step bolts most often will consist of a short, visual observation of the condition of the step bolts. Final paragraph (a)(7) permits workers to perform this visual inspection as they begin to climb the structure, so long as the workers inspect the step bolts before stepping on, or grasping them, and know not to proceed if the step bolts do not pass the visual inspection. Where a worker or supervisor identifies a problem during a visual inspection, a more thorough examination may be necessary. The employer must repair, correct, or

replace the damaged or hazardous step bolt before allowing workers to continue climbing the structure.

OSHA notes the proposed rule, like 1990 proposed § 1910.24(c)(4), specified that employers inspect step bolts visually "before each use." The phrase "before each use" means before the worker climbs the step bolts for the first time at the start of the work shift. It does not mean that employers must, throughout a work shift, have workers inspect the step bolts each time they climb them. OSHA understands that workers may climb step bolts multiple times during a work shift, and believes that inspecting step bolts at the initial climb is sufficient. OSHA did not receive any comments on the inspection requirement and adopts the requirement as discussed.

Final paragraph (a)(9), like the proposed rule, requires that employers ensure any step bolt that is bent more than 15 degrees from the perpendicular, in any direction, is removed and replaced with a bolt that meets the requirements of the section, before a worker uses it. OSHA believes this provision is necessary because step bolts bent to such a degree are not safe for workers to use. Regardless of the direction of the bend, it could cause the worker to slip or fall off the step bolt. If the bend in a step bolt is more than 15 degrees below horizontal, a worker's feet may slip or slide off the end of the step bolt. If the bend in a step bolt extends upwards more than 15 degrees, it is likely to reduce the minimum clear step width (4.5 inches) necessary to ensure the worker has a secure and safe foothold (final paragraph (a)(4)).

The final rule also requires that employers ensure that step bolts used for replacement meet the all of the requirements of final paragraph (a). This requirement will ensure that replacement step bolts provide workers with the maximum level of protection afforded by paragraph (a).

OSHA drew final paragraph (a)(9) from 1990 proposed § 1910.24(c)(5). OSHA did not receive any comments on paragraph (a)(9), and adopts it as discussed.

Paragraph (b)—Manhole Steps

Final paragraph (b) addresses the design, capacity, and use of manhole steps. There are no requirements specifically addressing manhole steps in existing subpart D, although OSHA's Telecommunications standard establishes requirements to protect workers who use metal ladders in manholes (§ 1910.268(h)(8)). OSHA drew most of the manhole step requirements from the 1990 proposed

Walking and Working Surfaces and Personal Protective Equipment (Fall Protection Systems) standard (55 FR 13360), which drew its requirements from a 1989 proposed rule on Electric Power Generation, Transmission, and Distribution. OSHA did not believe that it was necessary to include the manhole step requirements in the Electric Power Generation, Transmission, and Distribution final rule because the 1990 proposed rule to revise subpart D included provisions on manhole steps.

Final paragraph (b)(1), like the proposed rule, requires that employers ensure manhole steps are capable of supporting their maximum intended load, as defined in § 1910.21(b). As mentioned in the discussion of final paragraph (a)(6), final § 1910.22(b) requires that employers ensure all walking-working surfaces are able to support the maximum intended load that employers reasonably anticipate placing on them. Final paragraph (b)(1) emphasizes that the maximum intended load requirement in the final rule applies to existing manhole steps, regardless of when the employer installed them. Manhole steps that cannot support the maximum intended load without failure are not safe to use.

OSHA based the provision on 1990 proposed § 1910.24(c)(2), which also specified that existing manhole steps be capable of supporting their maximum intended load. The ASTM C 478 standard requires vertical and horizontal load testing of manhole steps in accordance with ASTM Test Methods C 497 (Section 16.6.1.3) (Ex. 382).

Final paragraph (b)(1), like final paragraph (a)(6) of this section and final § 1910.22(b), is performance based. However, employers are free to use the test procedures in ASTM C 478 and C 497 in determining whether their manhole steps can support the maximum intended load the employer anticipates placing on them. OSHA did not receive any comments on this provision, and adopted it as proposed with minor editorial revisions.

Final paragraph (b)(2), like the proposal, establishes requirements for manhole steps installed on or after the effective date of the final rule. OSHA based most of these requirements on 1990 proposed § 1910.24, and ASTM C 478–13, with many of the manhole step requirements in 1990 proposed § 1910.24 applying only prospectively (e.g., 1990 proposed § 1910.24(b)(6), (b)(7), and (c)(3)(i)–(iv)). As mentioned earlier, OSHA believes that applying the manhole step requirements when employers install new or replacement steps is the most efficient and least disruptive way to implement the

requirements in final paragraph (b)(2). Manhole steps, compared to step bolts, are generally more expensive to replace, and such replacement may not be necessary when the manhole steps can support the maximum intended load, and the employer inspects them at the start of each work shift, and repairs or replaces them immediately after identifying damage or hazardous conditions.

Final paragraph (b)(2)(i), like the proposed rule, requires that employers ensure manhole steps have a corrugated, knurled, dimpled, or other surface that minimizes the possibility of a worker slipping. The final rule is consistent with the requirements for metal manhole ladders in OSHA's Telecommunications standard (§ 1910.268(h)(8)(v)). The 1990 proposed rule (proposed § 1910.24(b)(7)) specified the same requirement as final paragraph (b)(2)(i) for manhole steps.

OSHA believes this final rule is necessary to reduce workers' risk of slipping and falling. Underground manholes often have moisture and other slippery substances (*e.g.*, mud, grease) that can pose slip hazards for workers. Ensuring that workers have, and can maintain, a secure foothold when entering the manhole and climbing the manhole steps is important to protect them from injury. OSHA notes final paragraph (b)(2)(i) is performance based. Thus employers are free to use any type of surface preparation that effectively minimizes the risk of slipping. OSHA received no comments on the proposed provision and adopts the requirement as discussed.

Final paragraph (b)(2)(ii), like the proposal and final paragraph (a)(1) of this section for step bolts, requires that employers ensure manhole steps are constructed of, or coated with, material that protects against corrosion if the manhole steps are in an environment where corrosion may occur. The final rule is consistent with the Telecommunications standard (§ 1910.268(h)(8) introductory text and (h)(8)(vi)) and 1990 proposed § 1910.24(b)(6)). The Telecommunications standard also requires that employers, when selecting metal ladders, ensure that the ladder hardware must be constructed of a material that is protected against corrosion and that the metals used shall be selected as to avoid excessive galvanic action (§ 1910.268(h)(8)(vi)). The ASTM C 478 standard, however, addresses corrosion hazards using a different approach. The national consensus standard does not require that manhole steps consist of corrosion-resistant materials or have corrosion-

resistant coatings. Instead, it requires that ferrous metal steps not painted or treated to resist corrosion must have a minimum cross-sectional dimension of one inch. OSHA believes that requiring all manhole steps to consist of corrosion-resistant material or have corrosion-resistant coatings is more protective, and better effectuates the purposes of the OSH Act, than ASTM C 478. OSHA's final rule protects manhole steps from becoming corroded, while the ASTM C 478 standard requires that employers make ferrous metal steps with large cross-sectional dimensions so they will hold up against corrosion longer.

Furthermore, as discussed in final paragraph (a)(1) of this section for step bolts, OSHA believes that corrosive environments can weaken and cause damage to unprotected metals, including manhole steps. Corrosion resistance will help to prevent deterioration that can lead to failure of manhole steps. OSHA did not receive any comments on the provision and adopts it as proposed with minor editorial clarifications.

Final paragraph (b)(2)(iii), like the proposed rule, requires that employers ensure manhole steps have a minimum clear step width of 10 inches. The final rule is consistent with the ASTM C 478 standard (Section 16.5.2), as well as 1990 proposed § 1910.24(b)(2). The ASTM C 478 standard has been in place for many years, so OSHA believes that most manhole steps have a step width of at least 10 inches. OSHA did not receive any comments on paragraph (b)(2)(iii) and adopts it as proposed.

Final paragraph (b)(2)(iv), like the proposal, requires that employers ensure manhole steps are uniformly spaced at a vertical distance of not more than 16 inches apart, measured center to center between steps. As mentioned above, OSHA believes that uniform spacing helps to make climbing safe. The ASTM C 478 standard specifies a maximum vertical spacing of 16 inches. The 1990 proposed provision (proposed § 1910.24(b)(1)) specifies a uniform spacing of not less than six inches nor more than 18 inches apart.

Final paragraph (b)(2)(iv), like final paragraph (a)(3) of this section for step bolts, also allows spacing from the entry and exit surface to the first manhole step to be different from the spacing between the other steps. Additionally, OSHA added a standard method for measuring the distance—from center to center between steps. This measurement method and the allowance for different spacing of the first manhole step are common practices, and will provide the consistency needed to help protect

workers, who will be entering, exiting, and working in different manholes. OSHA did not receive any comments on this provision and adopts it as discussed.

Final paragraph (b)(2)(v), like the proposed rule, requires that employers ensure manhole steps have a minimum perpendicular distance of at least 4.5 inches measured between the centerline of the manhole step and the nearest permanent object in back of it. The minimum clear-distance requirement is consistent with 1990 proposed § 1910.24(b)(3) and ASTM C 478, indicating that 4.5 inches is the common, accepted clearance for manhole steps. This requirement will provide adequate foot and hand holds, which are necessary for workers to safely climb manhole steps. OSHA did not receive any comments on this provision and adopts it as proposed.

Final paragraph (b)(2)(vi), like the proposal and final paragraph (a)(2) of this section for step bolts, requires that employers ensure that manhole steps are designed, constructed, and maintained to prevent the worker's foot from slipping or sliding off the end of the manhole step, which can result in a fall or slip. The final rule is the same as 1990 proposed § 1910.24(b)(5).

The proposed rule specified that manhole steps be designed to prevent workers' feet from slipping off the end of the step. For the same reasons discussed above in final paragraph (a)(2) for step bolts, OSHA added "constructed and maintained" to the final rule. OSHA did not receive any comments on this provision and adopted it as revised.

Final paragraph (b)(3), like the proposed rule and final paragraph (a)(8) of this section for step bolts, requires that employers ensure manhole steps are inspected at the start of the work shift, and maintained in accordance with § 1910.22. 1990 proposed § 1910.24(c)(4) specified that manhole steps be maintained in a safe condition and visually inspected prior to each use. OSHA's reasons for requiring manhole step inspections at the start of each work shift are the same reasons as those discussed above in final paragraph (a)(8) and, therefore, are not repeated here.

The proposed rule specified that manhole steps be visually inspected before each use. Mr. Miller, of Ameren, objected to the proposed language, saying: "Manhole steps are inspected when entered. There should be no need for additional inspection which would only increase the time and have little to no impact on safety. This seems only to be a paperwork requirement and would

do little to protect workers from hazards” (Ex. 189).

OSHA is unclear what Mr. Miller means by “additional inspection,” specifically whether he is referring to the “before each use” language in the proposed rule or the requirement that employers also maintain manhole steps in accordance with final § 1910.22, which requires inspection of walking-working surfaces regularly and as necessary. The “before each use” language means that employers must ensure inspection of manhole steps before the first use in a work shift, and not every time a worker climbs on manhole steps. OSHA recognizes that workers may climb manhole steps multiple times during a work shift, and believes that inspecting the manhole steps when workers first use them during a work shift is sufficient. The final rule clarifies this point.

If Mr. Miller is referring to the inspections of walking-working surfaces employers must conduct in accordance with § 1910.22(d)(1), OSHA disagrees with Mr. Miller that such inspections are simply a paperwork burden that have no impact on safety. Conducting regular inspections ensures that hazards are identified and corrected in a timely manner, thereby preventing worker injury or death. Regular inspections also are important if workers do not use manhole steps daily or frequently. Inspections provide the assurances that walking-working surfaces such as manhole steps will be in a safe and useable condition when workers use them.

By contrast, the American Federation of State, County and Municipal Employees (AFSCME) recommended that OSHA strengthen the visual inspection requirement for existing manhole steps: “Our members report that many of these steps degrade due to exposure to the elements and are difficult to inspect visually. Often manholes are not entered regularly. We suggest the Agency require inventory of manholes that use permanent step ladders and that they be inspected annually” (Ex. 226). OSHA believes that the level of inspection the final rule requires provides far more protection than AFSCME recommends for existing manhole steps. Final paragraph (b)(3) requires that employers ensure each manhole step is inspected at the start of each work shift, which could amount to multiple inspections each workday, depending on the number of work shifts in a workday. OSHA believes that requiring inspection before initially using manhole steps in a work shift is more protective than using manhole

steps that were last inspected almost a year ago.

Final paragraph (b)(3) also requires that employers maintain manhole steps in accordance with final § 1910.22. That section requires employers to inspect walking-working surfaces regularly and as necessary, and to maintain them in safe condition. “Regular inspection” means that the employer has some type of schedule, formal or informal, for inspecting walking-working surfaces that is adequate to identify hazards and address them in a timely manner. For purposes of the final rule, “as necessary” means that employers must conduct inspections when particular workplace conditions, circumstances, or events occur that warrant an additional check of walking-working surfaces to ensure that they are safe for workers to use. For example, an additional inspection may be necessary to ensure that a significant leak or spill does not create a slip, trip, or fall hazard on a walking-working surface.

OSHA believes this combination of inspection requirements will ensure that employers identify and correct hazardous conditions, such as degradation due to corrosion, on a timely basis, even if workers do not use manhole steps regularly. In addition, the requirement that manhole steps must be capable of supporting the maximum intended load (§ 1910.22(b)) will supplement visual inspections to ensure that manhole steps are safe to use.

Section 1910.25—Stairways

Section 1910.25 of the final rule establishes requirements for the design and installation of stairways. OSHA carried forward the majority of these requirements from the existing rule (§ 1910.24, Fixed industrial stairs), and also drew a number of provisions from the following national consensus standards:

- American Society of Safety Engineers/American National Standard Institute (ASSE/ANSI) A1264.1–2007, Safety Requirements for Workplace Walking/Working Surfaces and Their Access; Workplace, Floor, Wall and Roof Openings; Stairs and Guardrail Systems (A1264.1–2007) (Ex. 13);
- National Fire Protection Association (NFPA) 101–2012, Life Safety Code (NFPA 101–2012) (Ex. 385); and
- International Code Council (ICC) International Building Code-2012 (IBC–2012) (Ex. 386).

Final § 1910.25 is titled “Stairways,” which replaces the “Fixed Industrial Stairs” title in the existing rule (see discussion of “fixed industrial stairs” below). The final rule (§ 1910.21(b))

defines a stairway as “risers and treads that connect one level with another, and includes any landings and platforms in between those levels.” Final § 1910.25, like the proposed rule, covers all stairways, including standard, ship, spiral, and alternating-tread type stairs, used in general industry (§ 1910.25(a)). OSHA organized final § 1910.25 by the types of stairways that the final rule covers, and revised the format to add a separate paragraph identifying the scope and application of the section, as follows:

- Paragraph (a), Application, which specifies the stairs the final rule covers and excepts;
- Paragraph (b), now titled General Requirements, which establishes the requirements that apply to *all* covered stairways;
- Paragraph (c), Standard Stairs; and
- Paragraphs (d) through (f), which specify requirements when employers use spiral stairs, ship stairs, and alternating tread-type stairs.

OSHA believes this revised format makes final § 1910.25 easier to understand and follow.

Final § 1910.25, like the proposal, replaces the term “fixed industrial stair” in the existing rule with the plain-language term “stairways.” In addition, in final § 1910.25, OSHA uses the term, “standard stairs,” that § 1910.21(b) defines as “a fixed or permanently installed stairway.” In the proposed rule, the Agency explained that “fixed industrial stairs” was the term in use when OSHA adopted the existing rule in 1971 from ANSI A64.1–1968 (now A1264.1–2007). The Agency said “standard stairs” was easier to understand and consistent with revised and updated national consensus standards (A1264.1–2007, NFPA 101–2006) and industry codes (IBC–2003) (75 FR 28881–82). Those standards and codes used “standard stairs,” “stairways,” and “fixed stairs” interchangeably, and none used or defined “fixed industrial stairs.”

OSHA requested comment about replacing the term “fixed industrial stairs,” particularly whether it would cause confusion or leave a gap in coverage. OSHA only received one comment from the National Fire Protection Association (NFPA), which supported the proposed change (Ex. 97). NFPA said standard stairs was consistent with NFPA 101–2009 (Sections 3.1 and 7.2.2.2.1). OSHA believes it is important to update terminology so standards are easy to understand and reflect current industry practice.

Paragraph (a)—Application

As mentioned, OSHA changed the title of final paragraph (a) to “Application.” OSHA believes that “Application” better describes the content of paragraph (a), which identifies what stairways the final rule covers and excludes. Final paragraph (a) is broad and comprehensive. The scope of the existing rule, § 1910.24(a), which covers “interior and exterior stairs around machinery, tanks, and other equipment, and stairs leading to or from floors, platforms, or pits,” also is comprehensive. However, OSHA believes the language in the final rule more clearly and fully explains the Agency’s objective, and ensures that the final rule does not inadvertently exclude any type of stairway used in general industry.

Final paragraph (a) also lists certain stairways that § 1910.25 does not cover, specifically:

- Stairs serving floating roof tanks;
- Stairs on scaffolds;
- Stairs designed into machines or equipment; and
- Stairs on self-propelled motorized equipment (e.g., motor vehicles, powered industrial trucks).

Stairs serving floating roof tanks. As discussed in the proposed rule, these types of stairs are not covered by recognized industry standards and the Agency does not have any information or sufficient evidence on how to regulate these stairs. OSHA requested information on these types of stairs in the proposed rule and did not receive comment. Therefore, OSHA has not included stairs serving floating roof tanks in the scope of this section.

Stairs on scaffolds. Final paragraph (a) retains the proposed exemption for stairs on scaffolds. Requirements for stairs on scaffolds are provided in the construction industry standards in § 1926.451. In the preamble to the proposed rule, the Agency explained that the purpose of the proposed exemption was to have employers comply with the requirements for stairs on scaffolds contained in § 1926.451. OSHA said the proposed approach would increase consistency among its standards, assist employers who perform both general industry and construction work, and minimize potential for confusion. This exemption is consistent with OSHA’s approach in final § 1910.27(a) for scaffolds used in general industry. OSHA believes that having employers who use scaffolding follow a single standard will reduce confusion and help ensure worker safety.

Stairs designed into machines or equipment and stairs on self-propelled

motorized equipment. Final paragraph (a) retains the proposed exemption from final § 1910.25 for stairs designed into machines or equipment and stairs on self-propelled motorized equipment, such as motor vehicles and powered industrial trucks. However, OSHA does not intend this exemption to apply to equipment that the existing standard (§ 1910.24) currently covers. For example, the exemption does not apply to equipment such as mobile well-servicing rigs²² that are transported to various oil and gas wells (*Delta Drilling Co. v. OSHC*, 91 F.3d 139 (5th Cir. 1996) (unpublished); *Basic Energy Services*, 25 BNA OSHC 1811 (No. 14–0542, 2015); *Poole Co., Texas Ltd.*, 19 BNA OSHC 1317 (No. 99–0815, 2000)).

The exemption for stairs designed into machines or equipment and stairs on self-propelled motorized equipment is consistent with the scope of A1264.1–2007 and other national consensus standards, none of which address those stairs either. In the proposed rule, the Agency explained that it did not have sufficient information about such stairs, and there were no national consensus standards or industry codes to turn to for guidance or best industry practices. Although OSHA requested comment and information, only the Society of Professional Rope Access Technicians (SPRAT) responded:

It is the recommendation of this commenter that any stairs not covered by recognized industry standards, and about which the Agency does not have sufficient information or evidence to regulate, simply be acknowledged as a potentially hazardous situation with provision for protection against falls required (Ex. 205).

SPRAT pointed out that IBC–2009 and A1264.1–2007 only cover stairs associated with buildings, and the scope and requirements of those standards do not include stairs on machines or equipment. Given that, SPRAT said it would be inappropriate for OSHA to use those standards to justify covering stairs on, or designed into, machines and

²² A mobile well-servicing rig, also referred to as a “workover rig,” consists of “a telescoping derrick; . . . articulating platforms to allow for differences in the respective well sites to which the rig travels; as well as many other implements that aid in the maintenance and upkeep of an existing well” (*Basic Energy Services*, 25 BNA OSHC 1811 (No. 14–0442, 2015)). Once the rig is placed on “stable ground” over the well head, the “rig-up” process begins (Id.). “[T]he platforms of the mobile well servicing rig are attached to the base of a derrick, which is a part of the drilling rig itself. . . . The servicing units, though mobile, are placed on stands while in use. . . . [T]he sole purpose of the [well-servicing rig] is to serve as a work platform” (*Poole Co., Texas Ltd.*, 19 BNA OSHA 1317 (No. 99–0815, 2000)). The rigging-up process also includes installation of guardrails, stairs and other implements related to ingress/egress and safety” (Id.).

equipment. SPRAT also argued that the rulemaking record did not have adequate information to support regulating such stairs. OSHA agrees with SPRAT and retains the exemption for those reasons.

Although final § 1910.25 does not apply to stairs designed into machines or equipment or stairs on self-propelled motorized equipment, OSHA notes that the OSH Act’s requirement that employers provide their workers with a place of employment that is free from recognized hazards that are causing, or are likely to cause, death or serious physical harm continues to apply (see 29 U.S.C. 654(a)(1)).

Final paragraph (a) eliminates the following existing exceptions:

Stairs to construction operations at private residences, articulated stairs installed on dock facilities and stairs used for fire exit purposes. Final § 1910.25 does not include the existing exemption for stairs to construction operations in private residences, and the exemption for articulated stairs installed on dock facilities. OSHA believes that, by specifying that final § 1910.25 only applies to stairs used in general industry it is no longer necessary to retain exemptions for stairs in construction operations in private residences or articulated stairs installed on dock facilities since general industry does not use such stairs. OSHA’s construction (29 CFR part 1926) and maritime (29 CFR parts 1915, 1917, and 1918) standards regulate these two types of stairs as stairs used for fire-exit purposes.

OSHA also did not include the existing exemption for stairs used for fire exit purposes in either the proposed or final rules for two reasons. First, OSHA recognizes that employers could use virtually all stairways for fire and emergency exits, which makes a special provision for fire-exit stairs unnecessary. Second, when workers use stairways to exit an area in the event of a fire, it is important that the stairways meet the safety requirements in § 1910.25 so workers are able to safely escape. The Agency notes that its Means of Egress standards (29 CFR part 1910, subpart E) supplement walking-working surfaces requirements, including those in § 1910.25, for those portions of exit routes, including stairways, that are “generally separated from other areas to provide a protected way of travel to the exit discharge” (29 CFR 1910.43(c)).

Paragraph (b)—General Requirements

Paragraph (b) of the final rule sets forth general requirements for all stairways covered by this section, while other provisions of § 1910.25 specify

requirements for specific types of stairways. The general requirements in the existing rule (29 CFR 1910.23 and 1910.24) only apply to fixed industrial stairs. However, OSHA believes it is necessary to apply these general requirements to all stairways used in workplaces to ensure that workers have adequate protection from fall hazards.

Final paragraph (b)(1), like proposed paragraph (a)(2), requires that employers ensure handrails, stair rail systems, and guardrail systems are provided in accordance with final § 1910.28. This provision is intended to protect workers from falling off stairways. The final rule revises the proposal in two ways. First, OSHA added “guardrail systems” to final paragraph (b)(1). There are places on stairways, such as a platform between two flights of stairs, where guardrails, not stair rail systems are used. This was OSHA’s intent in the proposed rule and is clarified for the final rule. There is no additional burden imposed on employers because they already must provide protection on unprotected sides and edges 4 feet or more above a lower level in accordance with final § 1910.28. Section 1910.29 of the final rule details the criteria these guardrail systems must meet.

Second, the Agency did not include the note from proposed paragraph (a)(2) in final paragraph (b)(1). The note was moved to § 1910.29(f)(1)(iii) in the final rule. The proposed note specified that the top rail of a stair rail system may also serve as a handrail when installed in accordance with § 1910.29(f). The Agency determined that the note primarily addresses criteria for stair rail systems and is more appropriately placed with the criteria requirements in § 1910.29. OSHA did not receive any comments on the proposed provision and adopted the provision with the clarifications discussed above.

Final paragraph (b)(2), like proposed paragraph (a)(3), requires employers to ensure that the vertical clearance above any stair tread to any overhead obstruction is at least 6 feet, 8 inches, as measured from the leading edge of the tread. Like the proposal, spiral stairs must meet the vertical clearance requirement specified by final paragraph (d)(3), which is 6 feet, 6 inches.

The required vertical clearance in the final rule is lower than the 7-foot minimum clearance in the existing requirement (§ 1910.24(i)). However, the 6-foot, 8-inch clearance is consistent with A1264.1–2007 (Section 6.12) and NFPA 101–2012. OSHA notes that Section 6(b)(8) of the Occupational Safety and Health Act of 1970 (OSH Act) (29 U.S.C. 655(b)(8)) requires

OSHA to promulgate rules that are consistent with existing national consensus standards or explain why differences better effectuate the purpose of the OSH Act. The Agency believes that the requirements in A1264.1–2007 and NFPA 101–2012 provide adequate protection and reflect accepted industry practice. OSHA also points out that stairways built in compliance with the existing clearance requirements already meet the final rule. OSHA did not receive any comments on the proposed provision.

Final paragraphs (b)(3) through (5) establish requirements for riser heights, tread depths, and stairway landing platform dimensions. The final paragraphs, which are consistent with existing subpart D, are the minimum criteria necessary to ensure worker safety when using stairs. The final provisions also contain minor non-substantive changes to increase clarity.

Final paragraph (b)(3), like proposed paragraph (a)(4), incorporates the requirement in existing § 1910.24(f) that employers ensure that stairs have uniform riser heights and tread depths between landings. OSHA believes that retaining this requirement is necessary because, in the Agency’s experience, even small variations in riser height can cause trips.

OSHA, however, is not carrying forward other language in existing § 1910.24(f). For example, the existing rule requires that employers ensure stair treads and nosings are slip-resistant. OSHA does not believe this provision is necessary because final § 1910.22 already addresses this hazard. To illustrate, § 1910.22(a)(3) requires employers to maintain walking-working surfaces free of hazards such as spills, and § 1910.22(d)(1) requires employers to maintain walking-working surfaces in a safe condition. Therefore, OSHA is not repeating this requirement in final § 1910.25.

Similarly, OSHA believes it is not necessary to include in final § 1910.25(b)(3) the existing language allowing employers to use “welded bar grating treads without nosings.” The final rule is performance-based so employers are free to use stairways constructed of any type of material that will meet the requirements of the final rule.

OSHA received comments on the proposed provision. In particular, NFPA argued that the uniform tread and riser dimensions in final paragraph (b)(3) are not achievable because the provision does not include construction tolerances. NFPA stated, “It is not technically possible to build stairs with consistent riser height and consistent

tread depth as construction tolerances creep into the process” (Ex. 97). To address this issue, NFPA recommended that OSHA incorporate the tolerances allowed in NFPA 101–2009, which permits an allowance of no more than $\frac{3}{16}$ inches in adjacent tread depth or riser height, and a tolerance of no more than $\frac{3}{8}$ inches between the largest and smallest tread or riser in any flight of stairs. NFPA stated that the recommendation would provide a “safety net for compliance” and would protect employers from an interpretation of “uniform” that does not permit any allowance for construction tolerances, or that permits tolerances that are less than the tolerances established in NFPA 101–2009 (Ex. 97).

OSHA believes that minor variations in tread depth and riser height, such as those allowed in NFPA 101–2012 and A1264.1–2007, are acceptable. OSHA understands that minor variations in tread depth and riser height due to construction tolerances are likely to occur when building stairs and these minor variations are acceptable under the final rule.

Final paragraph (b)(4), like proposed paragraph (a)(5) and existing § 1910.24(g), requires that employers ensure the size of stairway landings and platforms is not less than the stair width and not less than 30 inches in depth, as measured in the direction of travel. The final rule is consistent with A1264.1–2007 (Section 6.10). OSHA did not receive any comments on the proposed provision adopts the proposed language with only minor clarifications.

Final (b)(5), like proposed paragraph (a)(6), requires that, when a door or a gate opens directly onto a stairway, employers must provide a platform and ensure the swing of the door or gate does not reduce the effective usable depth of the platform to less than:

- 20 inches for platforms installed before the effective date of the final rule; and
- 22 inches for platforms installed on or after the effective date of the final rule.

The final and proposed rules revise the language of the existing rule (§ 1910.23(a)(10)), which requires employers to ensure that doors or gates do not reduce the effective usable depth to less than 20 inches, by increasing the effective usable platform depth by 2 inches for newly installed platforms. The final rule grandfathered in the 20-inch platform depth requirement for existing stairways. Increasing the platform depth requirement to a minimum 22 inches is consistent with

the current and earlier versions of A1264.1 (1995, 2002, and 2007).

The final and proposed rules use the term “effective useable depth.” The term means the portion of the platform that is beyond the swing of the door or gate where a worker can stand when opening the door or gate. As Figure D–7 in the regulatory text illustrates, the effective useable depth is that portion of the platform that extends beyond the swing radius of the door or gate when it is open fully to the leading edge of the stair. OSHA believes this term expressly clarifies that the minimum platform depth must consider the portion of the platform used to accommodate the swing of the door or gate.

The Agency requested comment on the proposed provision and the amount of unobstructed space necessary for landing platforms when doors or gates open directly onto them. Ameren Corporation commented:

The necessary landing outside the swing radius of any door is directly dependent upon the direction of the door’s swing in relation to the direction of travel. If the door opens in the direction of travel, much less clearance is needed for the employee. Since no objective evidence is available for one distance for all paths of travel, the clearance of door swing should remain as is and allow the employer to determine whether or not two more inches of clearance is necessary for the safety of their personnel (Ex. 189).

OSHA believes that adopting the 22-inch effective useable platform depth for newly installed stair platforms is appropriate. As mentioned earlier, OSHA drew the requirement from the A1264.1–2007 standard. The standard reflects the considered views of employers, employees, safety professionals, and others. The 22-inch requirement also was in the 1995 and 2002 editions of the A1264.1 standard. With the requirement in A1264.1–2007 being in effect since 1995, OSHA believes it clearly represents accepted industry practice. OSHA notes the 22-inch effective-depth requirement applies to platforms installed on or after the effective date of the final rule, which is January 17, 2017. OSHA believes that the phase-in time the final rule allows is more than adequate for employers who install platforms, gates, and doors on stairways.

Ameren Corporation also raised an issue about the compliance deadline for paragraph (b)(5):

Lead time for material orders are often quite longer than three months[,] often up to years to order material for large capital projects. Small projects with possibly only a small amount of material being required shouldn’t have much of an issue of complying depending on the manufacturer

capabilities and their imposed deadlines. Stipulations of “ordered” material should be imposed in regard to the date of the final rule because the time between ordering and placing into service is often greater than 90 days (Ex. 189).

The 22-inch platform depth requirement in the final rule is prospective: it only applies to stairways, platforms, doors, and gates installed on or after the effective date of the final rule, which is January 17, 2017. This provision gives employers a 60-day lead time after publication of the final rule to come into compliance with the requirement when they install new stairway platforms. OSHA does not believe that it is necessary to extend the compliance deadline any further, even though the Agency proposed 150 days. The Agency believes a 60-day compliance lead time is more than adequate given that the 22-inch requirement in the A1264.1 standard has been in place for more than 18 years. During this 18-year period, OSHA believes the vast majority of employers, as well as manufacturers, construction companies, and building owners, came into compliance with the 22-inch requirement. Therefore, OSHA requires employers to comply with the 22-inch effective useable platform depth requirement by the standard’s effective date.

Final paragraph (b)(6), like proposed paragraph (a)(7), requires that employers ensure stairs can support at least five times the normal anticipated live load, and never less than a concentrated load of 1,000 pounds, applied at any point on the stairway. This requirement is consistent with A1264.1–2007 and earlier versions, which have been in place for many years. OSHA believes that most existing stairs have been installed in accordance with the ANSI requirements, and, therefore, already are in compliance.

OSHA requires employers to apply this safe-load requirement to spiral stairs, ship stairs, and alternating tread-type stairs, as well as standard stairs. OSHA believes the safe-load requirement is necessary to protect workers from stair collapse due to overloading, regardless of the type of stairs they are using. OSHA notes that final paragraph (b)(6), like the ANSI standard, applies to all stairs that § 1910.25 covers.

For the purposes of final paragraph (b)(6), a “normal anticipated live load” means a dynamic load (e.g., temporary, of short duration, or moving) that an employer reasonably anticipates will or could be applied to the stairs (see letter

to Mr. M. Podlovsky, May 8, 2000).²³ A “concentrated load,” for the purposes of final paragraph (b)(6), is the load-application point where the structure would experience maximum stress. Thus, a normal live load is spread over the whole stair tread area, while a concentrated load refers to a load applied at one point on the stair tread.

Final paragraph (b)(6) includes revisions that OSHA believes will provide an equal or greater level of protection to workers than the existing and proposed rules. For example, final paragraph (b)(6) requires that employers ensure stairways “can support” the required load, while the existing (at § 1910.24(c)) and proposed rules specify that stairways must “be designed and constructed” to support the required load. The revision ensures that, in addition to the design and construction of the stairways, the employer has an ongoing duty to maintain the stairways to ensure they can continue to support the load applied to them without collapse.

The final rule also revises the default strength language to require that stairways be capable of supporting a concentrated load of not less than 1,000 pounds “applied at any point.” The existing rule requires that stairways be capable of carrying not less than a “moving” concentrated load of 1,000 pounds. OSHA believes the final provision provides equal or greater level of safety by making the final rule applicable to any single point on the stairs, particularly the point that experiences maximum stress. These revisions are consistent with A1264.1–2007. OSHA did not receive any comments on the proposed provision and adopts paragraph (b)(6) with the changes discussed.

Final paragraphs (b)(7) through (9) specify when and where employers must provide standard stairs, and under what conditions employers may use spiral, ship, or alternating tread-type stairs. In final paragraphs (b)(7) and (8), OSHA simplified and reorganized the existing rule (§ 1910.24(b)) to make the requirements clearer and easier to understand than the existing and proposed rules.

Final paragraph (b)(7), like proposed paragraph (a)(8) and existing § 1910.24(b), requires employers to provide standard stairs to allow workers to travel from one walking-working surface to another. The existing and final rules both recognize that standard

²³ OSHA letter to Mr. Podlovsky available at: http://www.osha.gov/pls/oshaweb/owadisp.show_document?p_table=INTERPRETATIONS&p_id=23731.

stairs are the principal means of providing safe access in workplaces and employers must provide them when operations necessitate “regular and routine travel between levels,” including accessing operating platforms to use or operate equipment. The final provision is consistent with A1264.1–2007 (Section 6.1).

For purposes of the final rule, OSHA describes “regular and routine travel” in much the same way as the existing rule in § 1910.24(b). The term includes, but is not limited to, access to different levels of the workplace daily or during each shift so workers can conduct regular work operations, as well as operations “for such purposes as gauging, inspection, regular maintenance, etc.” (existing § 1910.24(b)). “Regular and routine” also includes access necessary to perform routine activities or tasks performed on a scheduled or periodic, albeit not daily, basis, particularly if the tasks may expose employees to acids, caustics, gases, or other harmful substances, or require workers to manually carry heavy or bulky materials, tools, or equipment (existing § 1910.24(b)).

Final paragraph (b)(7) retains the existing provision allowing the use of winding stairways on tanks and similar round structures when the diameter of the tank or structure is at least 5 feet. OSHA notes that winding stairs on such tanks and structures still must meet the other general requirements for stairways specified in the final rule. This provision does not preclude the use of fixed ladders to access elevated tanks, towers, and similar structures, or to access overhead traveling cranes, etc., when the use of such ladders is standard or common industry practice. OSHA received no comments on the proposed requirement and adopted the provision with only minor editorial change.

Final paragraph (b)(8) allows employers to use spiral stairs, ship stairs, and alternating tread-type stairs (collectively referred to as “non-standard stairs”), but only when employers can demonstrate that it is not feasible to provide standard stairs.

The existing rule (existing § 1910.24(b)), which OSHA adopted in 1972 from ANSI A64.1–1968 pursuant to section 6(a) of the OSH Act (29 U.S.C. 655(a)), allows employers to use spiral stairs for “special limited usage” or as a secondary means of access but only where it is “not practical” for employers to provide standard stairs. The existing rule, however does not address either ship or alternating tread-type stairs.

The 1973 proposed rule would have allowed the use of ship stairs “in restricted spaces in which a fixed industrial stairway cannot be fitted” (38 FR 24300, 24304 (9/6/1973)), however, OSHA withdrew that proposal (41 FR 17227 (4/23/1976)). In a 1982 letter of interpretation, though, OSHA said if employers use ship stairs in accordance with the 1973 proposal, the Agency would consider it to be a *de minimis* violation of existing § 1910.24(e) (Letter to Edward Feege, August 20, 1982²⁴).

That year OSHA issued Instruction STD 01–01–011 (April 26, 1982) allowing the use of and establishing guidelines for “a newly developed alternating tread-type stair”²⁵ (See also, Letter to Mr. Dale Ordoyne, December 2, 1981²⁶). To ensure worker safety, the instruction stated that alternating tread-type stairs must be designed, installed, used, and maintained in accordance with manufacturer’s recommendations. In addition, OSHA said alternating tread-type stairs must meet the following requirements:

- The stairs are installed at a 70 degree angle or less;
- The stairs are capable of withstanding a minimum uniform load of 100 pounds per square foot with a design factor of 1.7 and the treads are capable of carrying a minimum concentrated load of 300 pounds at the center of any treadspan or exterior arc with a design factor of 1.7. If the alternating tread-type stairs are intended for greater loading, the employer must ensure the stairs are constructed to allow for additional loading; and
- The stairs are equipped with a handrail on each side to assist employees climbing or descending the stairs.

OSHA announced in both STD 01–01–011 and the 1982 letter of interpretation that it would include provisions on ship stairs and alternating tread-type stairs in the subpart D rulemaking. The 1990 proposal included provisions allowing employers to use spiral, ship, and alternating tread-type stairs and establishing design specifications for each type of stair (55 FR 13360, 13400 (4/10/1990)). No final rule came from that proposal either.

²⁴ Letter to Mr. Feege available from OSHA’s Web site at: http://www.osha.gov/pls/oshaweb/owadisp.show_document?p_table=INTERPRETATIONS&p_id=19042.

²⁵ OSHA Instruction STD 01–01–011 is available from OSHA’s Web site at: http://www.osha.gov/pls/oshaweb/owadisp.show_document?p_table=DIRECTIVES&p_id=1753.

²⁶ Letter to Mr. Ordoyne available from OSHA’s Web site at: http://www.osha.gov/pls/oshaweb/owadisp.show_document?p_table=INTERPRETATIONS&p_id=18983.

In 2002, in response to an Office of Management and Budget (OMB) request for comment on its Draft Report to Congress on the Costs and Benefits of Federal Regulations, the Copper and Brass Fabricators Council (CBFC) urged OSHA to revise the existing rule (§ 1910.24(b)) to allow the use of ship and spiral stairs in a broader range of situations:

OSHA regulations under some circumstance require the use of fixed ladders when spiral stairways or ship stairs would be safer . . . [S]ection 1910.24(e) prohibits any stairs with an angle of rise greater than 50 degrees. Unfortunately, it is very common to have a tight location in industry where there is insufficient space for stairs with an angle of 50 degrees or less. Traditionally, these areas would use ship stairs that have separate handles from the stair rail but steps that are less deep than the traditional 8 inch to 12 inch step. Otherwise, a spiral stair was used which allowed a deeper tread. Under the present regulation, industries are required to use rung ladders in these locations which is less safe than spiral stairs or ship stairs (Ex. 4).

The 2010 proposed rule expanded the existing standard to allow employers to use spiral, ship, and alternating tread-type stairs. Similar to the existing rule, the proposal allowed employers to use non-standard stairs for “special limited usage” and “secondary access,” but only when the employer can demonstrate it is “not practical” to provide standard stairs in either situation (proposed paragraph (b)(9)). The proposed rule did not define any of these terms. Also, A1264.1–2007 did not define “special limited use,” but OSHA explained in the preamble to the proposed rule that the International Building Code (IBC)–2009 identified “special limited usage” area as a space that is no more than 250 square feet (23 m²) and serves no more than five occupants” (75 FR 28882). The IBC–2009 also identifies “galleries, catwalks and gridirons” as examples of special limited usage areas (75 FR 28882).

Final paragraph (b)(8) differs from the proposed rule in several ways. First, final paragraph (b)(8) deletes the language in the proposed rule limiting the use of non-standard stairs to “special limited usage” areas and as a secondary means of access. Although the existing, proposed, and A1264.1–2007 standards permit employers to use non-standard stairs in special limited usage areas and for secondary access, none of these standards defines either term. OSHA believes eliminating those undefined terms makes the final rule easier to understand.

Second, the final rule replaces the proposed language (*i.e.*, “special limited usage and secondary access situations

when the employer can demonstrate it is not practical to provide a standard stairway”) with long-standing and familiar performance-based language (*i.e.*, “can demonstrate that it is not feasible to use standard stairs”). The language in the final rule is consistent with the legal requirements of the OSH Act. In addition, OSHA believes that the language in the final rule gives employers greater flexibility. For example, there may be places other than special limited use areas and secondary access situations where an employer can demonstrate that standard stairs are infeasible. The final rule allows employers to use non-standard stairs in those situations.

Third, the Agency believes the performance-based language in the final rule does a better job of targeting the areas where it is not possible to use standard stairs and, thus, provides more protection for workers than the existing and proposed rules. The final rule limits the use of non-standard stairs to those situations in which it is not possible to use standard stairs. For example, under the final rule, employers must use standard stairs in special limited usage areas if it is possible to install them.

OSHA requested comment on proposed rule, including whether the final rule also should identify additional or specific limited usage areas where employers can use non-standard stairs (75 FR 28882). Two stakeholders said OSHA should narrow the situations in which employers may use non-standard stairs (Exs. 97; 159). For example, NFPA stated:

[I]t appears that OSHA is proposing to allow other than Standard Stairs to be used as long as the employer shows a Standard Stair cannot be used. However, no criterion as to why a standard stair could not be used is provided. Section 1910.25(a)(9) seems to allow spiral stairs, ship stairs or alternating tread devices without any limits. NFPA suggests OSHA establish a bracket of circumstances when such devices can be used (Ex. 97).

In particular, NFPA recommended that OSHA limit the circumstances in which employers may use non-standard stairs to the following list, which are the circumstances where NFPA 101 Life Safety Code allows the use of non-standard stairs, such as alternating tread-type stairs:

- As a means to access unoccupied roof spaces;
- As a second means of egress from storage elevators;
- As a means of egress from towers and elevated platforms around machinery or similar spaces, and occupied by no more than three persons at the same time; and

- As a secondary means of egress from boiler rooms or similar spaces, and occupied by no more than three persons at the same time (NFPA 101–2009, Section 7.2.11.1).

NFPA added that incorporating the NFPA 101–2009 list would “close the gap created by the proposed language and greatly limit the circumstances by which ‘non-standard’ stairs are acceptable for use” (Ex. 97).

Similarly, Jacqueline Nowell, of the United Food and Commercial Workers Union (UFCW), recommended that OSHA adopt a definition of special limited usage that is narrower than the IBC–2009 definition:

The Agency refers to the ICC Building Code definition [of special limited usage] as “a space not more than 250 square feet (23m\2\ in area and serving not more than five occupants.” Work platforms in many packaging houses would meet this definition of “special limited usage.” By allowing the use of spiral stairs or other non-standard stairs, OSHA would be introducing a new and unnecessary hazard to the workers who must climb up and down from these platforms multiple times a day, wearing heavy and bulky layers of personal protective equipment. I urge OSHA to develop a more restricted definition of “special limited usage” in order to prevent falls and other injuries to these workers (Ex. 159).

On the other hand, Southern Company (Ex. 192) said the definition of “special limited usage” in IBC–2009 (*i.e.*, “a space not more than 250 square feet”) was too restrictive and urged OSHA to adopt a more flexible approach (Ex. 192). They pointed out that mezzanine storage space generally is a special limited use area, even though in many cases the space may exceed 250 square feet (Ex. 192). They recommended that OSHA follow the approach in STD 01–01–011 and its letters of interpretation and allow the use of non-standard stairs when space limitations make the use of standard stairs infeasible, regardless of whether the space is greater than 250 square feet (Ex. 192) (See Letter to Edward Feege (August 20, 1982) and Erin Flory (February 10, 2006)²⁷).

OSHA believes the performance-based language in final paragraph (b)(8) addresses many of the concerns the stakeholders raised. The language in the final rule provides the increased flexibility that Southern Company supports. At the same time, the final rule limits the use of non-standard stairs to those circumstances where, based on specific case-by-case evaluations and

demonstrations, it is not possible to use standard stairs. Thus, for example, if it is possible to use standard stairs in a space that is less than 250 square feet, the employer is not permitted to use non-standard stairs under the final rule. In conclusion, OSHA adopts final paragraph (b)(8) as discussed.

Final paragraph (b)(9), which is a new provision, requires employers to ensure that non-standard stairs are installed, used, and maintained in accordance with manufacturer’s instructions. Since 1982, OSHA Instruction STD 01–01–011 has applied this requirement to alternating tread-type stairs. Although final § 1910.22(d) already requires that employers inspect and maintain walking-working surfaces in a safe condition, OSHA believes that specifically requiring that non-standard stairs comply with the instructions or provisions the manufacturer has issued for the installation, use, and maintenance is critical to ensure that unique aspects of these stairs are identified and addressed. OSHA also believes this requirement is necessary to minimize potential risks inherent in spiral, ship, and alternating tread-type stairs (*e.g.*, reduced tread depth, increased stair angle, improper climbing techniques) and to ensure those stairs are safe for workers to use. OSHA notes that final paragraph (b)(9), like final § 1910.22(d), applies to existing spiral, ship, and alternating tread-type stairs as well as non-standard stairs installed after the final rule is effective.

Finally, the Agency notes the requirements for spiral, ship, and alternating tread-type stairs in final paragraphs (b)(8) and (9) that employers must follow are in addition to the other general requirements in final paragraph (b) and specific requirements in final paragraphs (d), (e), and (f), which also apply to non-standard stairs.

Paragraph (c)—Standard Stairs

Paragraph (c) of the final rule, like proposed paragraph (b), establishes specific requirements for standard stairs that apply in addition to the general requirements in final paragraph (b). OSHA believes these specific requirements are the minimum criteria necessary to ensure workers can negotiate standard stairs safely. The requirements in final paragraph (c) generally are consistent with the A1264.1–2007 standard and most of the requirements are in the existing rule.

Final paragraph (c)(1), like proposed paragraph (b)(1) and existing § 1910.24(e), requires employers to install standard stairs at angles between 30 and 50 degrees from the horizontal. The final rule is consistent with

²⁷ Available from OSHA’s Web site at: https://www.osha.gov/pls/oshaweb/owadisp.show_document?p_table=INTERPRETATIONS&p_id=25301.

A1264.1–2007, which permits employers to install standard stairways at angles between 30 and 70 degrees from the horizontal, depending on the type of stairs. The final standard includes a diagram explaining that the slope for standard stairs is 30 to 50 degrees (see Figure D–10). OSHA received no comments on the proposal and adopted the provision as proposed.

Final paragraphs (c)(2) and (3), like proposed paragraphs (b)(2) and (3), require that employers ensure standard stairs have a maximum riser height and minimum tread depth of 9.5 inches.²⁸ The final rule also includes an exception (final paragraph (c)(5)) on riser heights and tread depths for standard stairs installed prior to the effective date of the final rule, which is January 17, 2017. The exception specifies that employers will be in compliance with the riser height/tread depth requirements if they meet the dimensions specified in the note to final § 1910.25(c)(2) and (3), or if they use a combination that achieves the required angle range of 30 to 50 degrees.

The existing rule (§ 1910.24(e)) does not specify a maximum riser height or minimum tread depth for fixed stairs. Instead, it requires that fixed stairs be installed at an angle of 30 to 50 degrees from horizontal and allows employers to use any combination of uniform riser and tread dimensions that achieves a stairway angle within the required range. To assist employers, the existing rule (§ 1910.24(e), Table D–1) provides examples of riser height and tread depth combinations that will achieve the required angle range. The existing rule also specifies that employers may use riser and tread combinations other than those listed in Table D–1, provided they achieve a stairway angle that is within the required slope of 30 to 50 degrees.

Like the final rule, A1264.1–2007 (Section 6.5) requires a 9.5-inch maximum riser height and minimum tread depth. And like the existing rule, A1264.1–2007 also allows employers to use any combination of riser and tread dimensions that achieve a stair angle within the permissible range. OSHA notes that A1264.1–2007 (Section E6.4) specifies that the permissible angle range for “typical fixed stair” is 30 to 50 degrees, which is consistent with the existing and final rules.

²⁸ Riser height is a vertical distance that is measured from the tread (horizontal surface) of one step to the top of the leading edge of the tread above it. Tread depth is a horizontal distance that is measured from the leading edge of a tread to the point where that tread meets the riser (See § 1910.25, Figure D–8). This method of measuring riser height and tread depth is consistent with NFPA 101–2009 (Section 7.2.2.3.5) and IBC (Section 1009.7.2).

OSHA believes that the riser height and tread depth requirements in final paragraphs (c)(2) and (3), respectively, are simpler, clearer, and easier to understand and follow than the existing rule. The final rule also makes it easier for employers to achieve the required stair angle range of 30 to 50 degrees in final paragraph (c)(1).

OSHA received several comments on the proposed riser height and tread depth requirements. For example, Ellis Fall Safety Solutions (Ex. 155) advocated that OSHA follow the maximum riser heights and minimum tread depths of 7 and 11 inches, respectively, in IBC–2009, stating, “If other locations in commerce are 7/11 why should we not find that at work too? Also it is less tiring for workers to climb a 7/11 stair . . . OSHA should not be different than the IBC Building Code in this instance” (Ex. 155).

To reduce employer burdens, Ellis also suggested that the final rule include a provision grandfathering in the riser and tread dimensions of existing stairways until employers do “major renovation” of the stairs (Ex. 155). Southern Company agreed that OSHA should grandfather in existing stairways that have a tread depth of less than 9.5 inches, “[W]e have not seen data that an existing stairway with an 8 inch tread depth produces an increase in the fall exposure that would justify replacing these stairs. Absent data . . . we feel these stairs should be grandfathered” (Ex. 192).

NFPA, on the other hand, said there was “no technical justification” for allowing a tread depth of less than 9.5 inches, especially since it was more lenient than the 11-inch tread depth requirement in new IBC codes (Ex. 97).

OSHA agrees with NFPA that the 9.5-inch minimum tread requirement in the proposed, final, and A1264.1–2007 standards provides stepping space that is adequate to protect workers from falling. Although A1264.1–2007 (Section 6.5) requires a 9.5 maximum riser height and minimum tread depth, an explanatory note also suggests that employers consider the riser and tread requirements in IBC codes. OSHA notes that employers who have or install standard stairs with an 11-inch tread depth, which IBC–2009 requires, are in compliance with the final rule. Moreover, as mentioned above, OSHA grandfathers in the riser heights and tread depths of existing stairs even if they are less than 9.5 inches, which addresses the concerns of Southern Company.

OSHA removed from final paragraph (c)(3) the proposed exception from the minimum tread-depth requirement for

stairs with open risers. OSHA adopted the proposed exception from the 9.5-inch tread-depth requirement for open risers from A1264.1–2007. A note to that standard explained: “Open risers are needed on certain narrow tread and steep angled stair systems and exterior structures” (Section E6.13.).

NFPA opposed the proposed exception, saying that allowing a tread depth of less than 9.5 inches for open risers is problematic in two ways:

(1) Where open risers are present, not only does the specific 9.5-inch not apply, but no minimum tread depth is specified. The tread depth could be as little as 3–4 inches. (2) Stairs are used for travel in the downward direction at least as much as they are used for travel in the upward direction. An open riser might help to provide some extra “effective” tread depth for persons using the stair for upward travel. . . . [However,] [a]n open riser does not create greater effective tread depth for persons using the stair for downward travel (Ex. 97).

In addition, NFPA maintained that there is no technical justification for permitting a tread depth of less than 9.5 inches when the riser is open, stating, “The 9.5-inch minimum tread depth specified [in paragraph (c)(3)] is already lenient as compared to the minimum 11-inch tread depth required in new construction model codes. The exemption for open risers should be deleted” (Ex. 97). OSHA agrees with NFPA and, therefore, removed the proposed exception for standard stairways with open risers from the final rule.

Final paragraph (c)(4), like proposed paragraph (b)(4), requires that employers ensure standard stairs have a minimum width of 22 inches between vertical barriers. Examples of vertical barriers include stair rails, guardrails, and walls. The added language makes the final provision more protective than the existing rule (§ 1910.24(d)), which also requires a tread width of 22 inches but does not specify how to measure the width. The additional language makes the final rule consistent with A1264.1–2007, which requires a minimum clear width of 22 inches. OSHA did not receive any comments on the proposed provisions and adopts the provision as proposed.

The requirements for non-standard stairs in final paragraphs (d) (spiral stairs), (e) (ship stairs), and (f) (alternating tread-type stairs) parallel most of the provisions established for standard stairs in paragraph (c). Like the requirements for standard stairs, the requirements for spiral, ship, and alternating tread-type stairs represent the minimum requirements OSHA believes are necessary to ensure that

employees are able to move safely from one walking-working surface to another. OSHA adopted the requirements for non-standard stairs from A1264.1–2007, NFPA 101–2012, and IBC–2012.

Paragraph (d)—Spiral Stairs

Final paragraph (d), like proposed paragraph (c), establishes specific requirements for spiral stairs. As mentioned earlier, these requirements apply in addition to the general requirements in paragraph (a). OSHA adopted most of the requirements in final paragraph (d) from NFPA 101–2012. OSHA believes that the vast majority of spiral stairs currently in use already meet the requirements in final paragraph (d) because these spiral stairs conform to the current industry practice expressed in this NFPA standard. Therefore, OSHA believes employers will not have difficulty complying with the final rule.

Final paragraph (d)(1), like paragraph (c)(1) of the proposed rule, requires that employers ensure spiral stairs have a minimum clear width of 26 inches. The “clear” width requirement in final paragraph (d)(1) is similar to the approach in final paragraph (c)(4) and A1264.1–2007 (Section 6.3). That is, the width is measured from the vertical barrier on the outside of the stairway to the inner pole onto which the treads are attached. Spiral stairs need a greater width than standard stairs because only the outside portion of the stairs can be stepped on since the inner part of treads are too short in depth. OSHA did not receive any comments on the proposed provision and adopts the provision as proposed.

Final paragraph (d)(2), like proposed paragraph (c)(2) and final paragraph (c)(3), requires that employers ensure that spiral stairs have risers with a maximum height of 9.5 inches. OSHA did not receive any comments on the proposed provision, and the final rule adopts the provision as proposed.

Final paragraph (d)(3) requires that employers ensure spiral stairs have a minimum headroom above the spiral stair treads of at least 6 feet, 6 inches. The final rule also requires that employers measure the vertical clearance from the leading edge of the tread. This requirement means that, at any and every point along the leading edge, the minimum headroom must be at least 6 feet, 6 inches. The proposed rule (paragraph (c)(3)) specifies that same minimum headroom, but proposed to measure it at the center of the leading edge of the tread. OSHA believes it is necessary to revise the method for measuring the vertical clearance to prevent injury to workers when using

spiral stairs. The minimum headroom the final rule requires for spiral stairs is two inches less than the headroom final paragraph (b)(2) requires for all other stairways. Because the required headroom is less, OSHA believes it is important that employers measure the required minimum headroom at all points along the leading edge. OSHA did not receive any comments on the provision and adopts the proposed provision with the change discussed.

To ensure that workers are able to maintain safe footing while using spiral stairs, final paragraph (d)(4), like proposed paragraph (c)(4), requires that employers ensure spiral stairs have a minimum tread depth of 7.5 inches. Because the tread depth on a spiral stair is not the same across the width of the tread, the final rule also requires that employers measure the minimum tread depth at a point 12 inches from the narrower edge. This requirement ensures that workers will have adequate space at the point on the tread where they are most likely to step.

Although the minimum tread depth final paragraph (d)(4) requires is less than that for standard stairs, OSHA has several reasons for concluding that the minimum 7.5-inch tread depth is adequate to provide safe footing for workers. First, spiral stairs usually have open risers that provide additional space for the foot. Second, employers use spiral stairs where space restrictions make the use of standard stairs infeasible. In restricted-space situations, there may be insufficient room for stairways with 9.5-inch tread depths. Third, final paragraph (d)(4) is consistent with NFPA 101–2012. OSHA did not receive any comments on the proposal and adopts the provision as proposed.

Final paragraph (d)(5), like proposed paragraph (c)(5), requires that employers ensure spiral stairs have a uniform tread size. As OSHA mentioned in the discussion of paragraph (b)(3), this requirement is necessary because, in the Agency’s experience, even small variations in tread size and shape may cause trips and falls. OSHA did not receive any comments on the proposed rule and adopts it as proposed.

Paragraph (e)—Ship Stairs

Final paragraph (e), like proposed paragraph (d), provides specific requirements employers must follow in situations where they may use a type of stair commonly referred to as a “ship stair” or “ship ladder.” Employers often use ship stairs as a means to bypass large equipment, machinery, or barriers in tight spaces. OSHA drew some of the

provisions in final paragraph (e) from the A1264.1–2007 standard.

The requirements in final paragraph (e) apply in addition to the general requirements specified in paragraph (a) above. In addition, OSHA is reorganizing some of the provisions in final paragraph (e) to make the paragraph easier to follow and understand. For example, OSHA is grouping the riser requirements into one provision (final paragraph (e)(2)).

OSHA notes that the requirements in final paragraph (e) apply only to ship stairs used in general industry. Some commenters raised concerns about whether OSHA was applying the requirements in paragraph (e) to ship stairs used on vessels. For example, Northrop Grumman Shipbuilding (NGS) said:

OSHA has included a definition (§ 1910.21(b)) and design requirements for ship stairs. . . . [W]e wish to clarify that despite the inclusion of the term “ship stairs” in the standard, OSHA is not attempting to extend application of the design criteria for ladders, stairs or other walking-working surfaces to vessels, which we believe are under the regulatory authority of the United States Coast Guard (Ex. 180).

Mercer ORC Networks raised similar concerns:

Mercer believes that OSHA intends to apply this definition to a particular stair or ladder configuration wherever it is found, whether on a ship or in a land-based facility. However, if one reads the definition literally (which should be possible with regulations), one might easily conclude that unless the stairs or ladder are actually aboard a ship, they do not fit the regulation (Ex. 254).

Using the longstanding industrial term “ship stairs” does not mean that this final rule applies to any industry sectors or workplaces beyond general industry, or working conditions regulated by other agencies. As mentioned in § 1910.21, OSHA considers “ship stairs” to be a term of art for a type of stairway used when standard stairs are not feasible. OSHA recognizes that, historically, vessels used ship stairs to access different levels in restricted spaces. Today, however, employers use these stairs in other situations, including general industry workplaces. OSHA continues to use the term in the final rule to refer to a particular stair design, and not to designate where employers install or use them (see discussion of ship stairs in § 1910.21(b)).

Final paragraph (e)(1), like paragraph (d)(1) of the proposed rule, requires that employers ensure ship stairs are installed at a slope of 50 to 70 degrees from the horizontal. As A1264.1–2007 indicates, this slope range is standard

for ship stairs (see Figure 6.4 of A1264.1). OSHA did not receive any comments on the proposed provision and adopts it as proposed.

Final paragraph (e)(2), like paragraph (d)(2) of the proposed rule, addresses risers on ship stairs. First, the provision requires that employers ensure ship stairs have open risers. The final rule is consistent with A1264.1–2007 (Section 6.13), which requires that ship, spiral, and alternating tread-type stairs having a tread depth of less than 9.5 inches must have open risers. The A1264.1–2007 standard explains that open risers are necessary for stairs with narrow tread depth, such as stairs used in restricted space (Sections E6.5 and E6.13). An open riser gives workers additional space to ensure they are able to maintain safe footing on treads that have a narrow tread depth due to the limited space.

Second, final paragraph (e)(2), like proposed paragraph (d)(3), requires that employers ensure ship stairs have a vertical rise between tread surfaces of at least 6.5 inches and not more than 12 inches. For clarity, OSHA moved the proposed requirement to paragraph (e)(2) because it also addresses stair risers. OSHA did not receive any comments on the proposed ship stair requirements for open risers and acceptable riser height and adopts the provision as proposed.

Final paragraph (e)(3), like proposed paragraph (d)(3), requires that employers ensure ship stairs have a minimum tread depth of 4 inches. Employers must apply final paragraph (e)(3) in combination with paragraph (e)(2). Although the required 4-inch minimum tread depth for ship stairs is less than the 9.5-inch minimum tread depth required for standard stairs (final paragraph (c)(3)), nevertheless, OSHA believes the tread depth is adequate to ensure that workers have a safe stepping area because final paragraph (e)(2) requires that ship stairs have open risers. As discussed, open risers give workers additional space to maintain safe footing on ship stairs. Also, together the riser and tread requirements in final paragraphs (e)(2) and (3), respectively, set the necessary framework for employers to achieve the required 50- to 70-degree angle range for ship stairs. OSHA did not receive any comments on the proposed provision and adopts the provision as discussed.

Final paragraph (e)(4), like proposed paragraph (d)(3), requires that employers ensure ship stairs have a minimum tread width of 18 inches. Although the required tread width for ship stairs is 4 inches less than that specified in final paragraph (c)(4),

OSHA believes this width is adequate for stairs that employers may use only in certain limited situations, such as in restricted spaces where it is not feasible to use standard stairs. OSHA notes that the final rule makes the tread-width requirement a stand-alone provision, which makes paragraph (e)(4) consistent with the other tread-width provisions in § 1910.25. The Agency did not receive any comments on the proposed tread width provision and adopted it as proposed.

Paragraph (f)—Alternating Tread-Type Stairs

Final paragraph (f), like proposed paragraph (e), establishes specific requirements for those situations in which employers may use alternating tread-type stairs. The requirements in final paragraph (f) apply in addition to the general requirements in final paragraph (b). The Agency based the requirements on OSHA Instruction STD 01–01–011 and three national consensus standards (A1264.1–2007, NFPA 101–2012, and IBC–2012).

Final paragraph (f)(1), like proposed paragraph (e)(1), requires that employers ensure the series of treads installed in alternating tread-type stairs have a slope of 50 and 70 degrees from the horizontal. As A1264.1–2007 indicates, this slope range is standard for alternating tread-type stairs (see Figure 6.4). Final (f)(1) also is consistent with OSHA Instruction STD 01–01–011, which specifies that alternating tread-type stairs must have a slope angle of 70 degrees or less. OSHA did not receive any comments on the proposed requirement and adopts the provision as proposed.

Final paragraph (f)(2), like proposed paragraph (e)(2) and proposed § 1910.28(b)(11)(iii), specifies the required horizontal distance between handrails. It requires that employers ensure the distance between the handrails on alternating tread-type stairs is not less than 17 inches and not more than 24 inches.

OSHA Instruction STD 01–01–011, which allows employers to use alternating tread-type stairs, does not specify a minimum width between handrails. The existing (§ 1910.24(d)), proposed (proposed paragraph (b)(4)), and final rules (final paragraph (c)(4)) require that employers ensure standard stairs have a minimum 22-inch tread width between vertical barriers (*i.e.*, handrails). Similarly, A1264.1–2007 (Section 6.3) requires that all fixed stairs have a minimum “clear width” of 22 inches, which, in other words, means that the distance between handrails must be at least 22 inches.

OSHA believes the handrail distance requirement in the final rule better effectuates the purposes of the OSH Act than A1264.1–2007. First, alternating tread-type stairs can pose unique issues. OSHA believes the 17- to 24-inch handrail distance is appropriate and provides needed flexibility to address those issues. For example, as A1264.1–2007 (Section E6.1.1) points out, some alternating tread-type stairs are built so that workers need to descend facing away from the stairs, which makes three-point contact “a necessity.” For those stairs, OSHA believes that the distance between handrails may need to be adjusted so workers are able to maintain critical three-point contact while they are descending the stairs.

Second, the final 17- to 24-inch handrail distance requirement is established specifically for the alternating tread-type stairs. By contrast, the 22-inch width requirement in A1264.1–2007 applies to all fixed stairs and does not take into consideration the issues and limitations involved with alternating tread-type stairs. Therefore, OSHA believes the flexibility that final paragraph (f)(2) provides, combined with its specific consideration of the issues involving alternating tread-type stairs, ensures that the final rule will provide appropriate protection.

Finally, adopting a 17- to 24-inch handrail distance is consistent with the NFPA 101–2012 requirement for alternating tread-type stairs (Section 7.2.11.2). Unlike A1264.1–2007, the NFPA 101 standard establishes handrail width requirements specific to alternating tread-type stairs and the unique issues and limitations those stairs involve. OSHA is therefore following the NFPA 101–2012 standard in accordance with section 6(b)(8) of the OSH Act (29 U.S.C. 655(b)(8)).

OSHA notes that since 1986, OSHA Instruction STD 01–01–011 has required that alternating tread-type stairs “be equipped with a handrail on each side” to assist workers using the stairs. Final paragraph (f)(2) (*i.e.*, “between handrails”) is consistent with that instruction. OSHA did not receive any comments on proposed paragraph (f)(2) and adopts as discussed.

Final paragraphs (f)(3) and (f)(4) address tread depth for alternating tread-type stairs. Final paragraph (f)(3), like proposed paragraph (e)(3), requires that employers ensure alternating tread-type stairs have a tread depth of at least 8.5 inches. However, if the tread depth is less than 9.5 inches, final paragraph (f)(4), like proposed paragraph (e)(4), requires that employers ensure alternating tread-type stairs have open risers. The A1264.1–2007 standard

contains the same requirement (Section 6.13), explaining that open risers are necessary on stairs with narrow treads (Section E6.13). OSHA did not receive any comments on the proposed provisions, which the final rule adopts with only minor editorial changes.

Final paragraph (f)(5), like proposed paragraph (e)(5), requires that employers ensure that each tread has a minimum width of 7 inches measured at the leading edge (nosing) of the tread. The measurement is taken at the leading edge of the tread because treads on many of these types of stairs narrow at the back of the tread. This requirement is based on a requirement in the IBC–2012 (§ 1009.13.2). OSHA did not receive any comments on the proposed requirements and adopts the provisions as proposed.

Section 1910.26—Dockboards

Section 1910.26 of the final rule establishes requirements for the design, performance, and use of dockboards. The final rule updates the existing requirements for dockboards (existing § 1910.30(a)).²⁹ For example, the final rule deletes the existing requirement that the design and construction of powered dockboards conform to the 1961 Department of Commerce (DOC) Industrial Lifts and Hinged Loading Ramps Commercial Standard (CS202–56). ANSI/ITSDF B56.1 (2012) and other recently updated national consensus standards supersede the DOC standard. These standards include:

- American National Standards Institute (ANSI)/Industrial Truck Standards Development Foundation (ITSDF) B56.1–2012, Trucks, Low and High Lift, Safety Standard (B56.1–2012) (Ex. 384);
- ASME/ANSI MH14.1–1987, Loading Dock Levelers and Dockboards (MH14.1–1987) (Ex. 371);
- ANSI MH30.1–2007, National Standard for the Safety Performance, and Testing of Dock Loading Devices (MH30.1–2007) (Ex. 372); and
- ANSI MH30.2–2005, Portable Dock Loading Devices: Standards, Performance, and Testing (MH30.2–2005) (Ex. 20).

Both the proposed and final rules adopted provisions that generally are consistent with these national consensus standards. Final § 1910.26

applies to all dockboards unless a provision states otherwise.

The final rule (final § 1910.12(b)) defines a dockboard as a portable or fixed device used to span a gap or compensate for a difference in height between a loading platform and a transport vehicle. Dockboards may be powered or manual, and include, but are not limited to, bridge plates, dock levelers, and dock plates.

“Loading platforms,” as used in the definition of dockboards, include loading docks, interior floors, driveways or other walking or working surfaces. “Transport vehicles,” as used in the definition and in the final rule, are cargo-carrying vehicles that workers may enter or walk onto to load or unload cargo and materials. Transport vehicles include, but are not limited to, trucks, trailers, semi-trailers and rail cars. Employers primarily use transfer vehicles on dockboards in order to move cargo and materials on and off transport vehicles. “Transfer vehicles,” which are mechanical powered or non-powered devices to move a payload, include, but are not limited to, powered industrial trucks, powered pallet movers, manual forklifts, hand carts, hand trucks, and other types of material-handling equipment. Transfer vehicles include all mechanical handling equipment that 29 CFR part 1910, subpart N, covers.

These descriptions of transport vehicles and transfer vehicles are consistent with the definitions of those terms in the MH30.1–2007 and MH 30.2–2005 consensus standards. In proposed § 1910.26(d), OSHA used the term “equipment” to reference all types of transfer vehicles. OSHA believes the term “transport vehicle” more accurately describes the types of equipment OSHA intends to cover in final § 1910.26.

Paragraph (a) of the final rule, like proposed paragraph (a), requires that employers ensure that the dockboards are capable of supporting their maximum intended load. Section 1910.21(b) of the final rule defines “maximum intended load” as the total load (weight and force) of all workers, equipment, vehicles, tools, materials, and other loads that the employer “reasonably anticipates” to be applied to a walking-working surface at any one time. OSHA recognizes that not all dockboards are equal, and some employers may have multiple dockboards with different capacities. Some dockboards are made of lightweight materials, such as aluminum, designed to support lighter loads such as those that typically occur with manual material handling methods. Other dockboards, such as

those made of steel, are typically designed to accommodate a heavier load, such as a laden powered industrial truck. Additionally, portable dockboards may be carried on transport vehicles for use at various loading platforms and subjected to a wide range of anticipated loads.

The final rule differs from existing § 1910.30(a)(1) in that the existing rule requires dockboards to be strong enough to carry the load imposed on them. As OSHA explains in the discussion of final § 1910.21(b), the term “maximum intended load” applies not only to total loads currently applied to a walking-working surface, such as a dockboard, but also to total loads that the employer has a reasonable anticipation will be placed on the walking-working surface.

The provision for loads in final § 1910.22(b) requires that employers ensure all walking-working surfaces are capable of supporting the maximum intended load that will be applied to that surface. OSHA believes it is important for clarity to include this performance-based requirement in § 1910.26. OSHA included the provision in final § 1910.26(a) to emphasize that the final rule revised the load criteria in the existing rule from “load imposed” to “maximum intended load.” Also, OSHA included the load requirement in this section to emphasize that it applies to all dockboards that workers use, regardless of whether the employer or some other entity owns or provides the dockboard; whether the dockboard is portable, fixed, powered, or manual; or whether the employer uses the dockboard as a bridge to a transport vehicle. Finally, OSHA included the requirement in this section to stress that, consistent with MH14.1–1987 (Section 2), the design and construction of all load-supporting parts of the dockboard must ensure that the dockboard unit as a whole, when under load, is capable of supporting the maximum intended load.

The national consensus standards also provide guidance to help employers comply with final paragraph (a). For example, MH14.1–1987 and MH30.2–2005 identify factors and circumstances employers should consider when ensuring their dockboards meet the load requirement in final paragraph (a): “In selecting dock leveling devices, it is important [for employers/owners] to consider not only present requirements but also future plans or adverse environments” (MH14.1–1987 (Section 3.1(j)) and MH30.2–2005 (Section 6.2.9)).

The MH14.1–1987 standard requires that load-supporting parts of dockboards, including structural steels

²⁹The final rule also deletes the existing requirements for forging machine areas and veneer machinery in existing § 1910.30(b) and (c), respectively. OSHA believes these requirements are not necessary because § 1910.22(b) of the final rule, as well as other general industry standards (e.g., 29 CFR part 1910, subpart O (Machinery and Machine Guarding)) already address those hazards. For example, subpart O includes standards on forging machines (§ 1910.218).

and other materials, when under load, conform to American Society for Testing and Materials (ASTM) standards, and that all welded connections on dockboards comply with American Institute of Steel Construction standards (Sections 2(a) and (b)). Similarly, the MH30.1–2007 standard recommends that owners and employers never use dockboards outside the manufacturer's rated capacity (Section 5.4.10). OSHA believes the guidance these national consensus standards provide will help employers ensure that dockboards are able to carry, and do not exceed, the maximum intended load. OSHA did not receive any comments on the proposed provision and adopts it with editorial revisions.

Final paragraph (b)(1), like the proposed rule, requires employers to ensure that dockboards put into initial service on or after the effective date of the final rule, January 17, 2017, are designed, constructed, and maintained to prevent transfer vehicles from running off the dockboard edge. In other words, dockboards put into service for the first time starting on the effective date of the final rule must have run-off protection, guards, or curbs. A "run-off guard," as defined in the MH14.1–1987 standard, is "a vertical projection running parallel with the normal traffic flow at each side extremity of the dockboard. Its intent is to avoid accidental side exit" (Section 1.3; see also MH30.1–2007 (Section 1.2.16) and MH30.2–2005 (Section 2.9)). For example, run-off protection on many dockboards is simply a lip on the side of the dockboard that is bent 90 degrees from the horizontal portion of the dockboard. The existing rule does not include a similar requirement.

OSHA believes this provision is necessary to protect workers. A transfer vehicle that runs off the side of a dockboard could kill or injure employees working on or near it. For example, forklifts used to load items onto a transport vehicle could seriously injure or kill the operator and nearby workers if the forklift runs off the side of the dockboard. In addition, workers using hand trucks to load and unload materials from a truck could lose their balance and fall if there is no run-off guard to prevent the hand truck from running off the side of the dockboard.

Final paragraph (b)(1) is a performance-based version of the run-off protection requirements in national consensus standards. To illustrate, the MH14.1–1987 standard specifies:

Run-off guards shall be used for units that bridge an opening in excess of 36 in. (910 mm) from the face of the dock. The minimum run-off guard height shall be 2¾ in (70 mm)

above the plate surface. Ends of run-off guards shall be contoured both horizontally and vertically to permit a smooth transition to minimize damage to the tires of handling equipment. (Section 3.2(a); see also Sections 3.4(c), 3.5, 3.6.)

The MH30.1–2007 and MH30.2–2005 standards also contain similar specifications (MH30.1–2007 (Sections 5.3.2, 5.3.3) and MH30.2–2005 (Section 6.1.4)) to prevent transfer equipment from accidentally running off the side of the dockboard. OSHA will deem employers that comply with the run-off protection specifications in MH14.1–1987, MH30.1–2007, or MH30.2–2005 as being in compliance with final paragraph (b)(1). OSHA also will consider employers that follow a different approach, or use dockboards with run-off guards of a different height, to be in compliance with the final rule, provided the run-off guards they use are effective in preventing transfer vehicle from running off the dockboard side.

OSHA made several revisions to proposed paragraph (b) in the final rule. First, final paragraph (b)(1) clarifies that this provision is prospective only, that is, it only applies to dockboards put into "initial service" on or after the effective date of the final rule. The final rule grandfathers existing dockboards (75 FR 29009–10), meaning employers do not have to replace or retrofit dockboards currently in use.

Second, OSHA revised the compliance deadline for this provision. The effective date specified by the proposed rule was 90 days after the effective date of the final rule. After reviewing the record, OSHA does not believe that the longer proposed compliance phase-in period is necessary because the national consensus standards on which OSHA based final paragraph (b) have been in place for many years. As such, OSHA believes many dockboards currently in use, and virtually all dockboards manufactured today, already have run-off guards. Therefore, OSHA does not believe the compliance date in final paragraph (b) will impose an undue burden on employers.

Third, OSHA added an exception (final paragraph (b)(2)) in response to a comment the Agency received on the proposed provision. The American Trucking Associations, Inc., (ATA) (Ex. 187) said the proposed rule was "very broad" and opposed the requirement that all dockboards have run-off protection:

To load or to unload, the driver of the commercial motor vehicle backs up to the dock slowly and does not stop until contacting the dock or the installed dock bumper blocks. In most cases, the gap

between the vehicle and the loading dock is no more than a few inches. Either a dock leveler or portable dockboard is used to reduce even this minimal amount of space. There is insufficient space between the terminal and the truck to permit a powered industrial truck loading or unloading freight to fall to the ground.

OSHA's proposed requirement that portable dockboards and dock plates be provided with edging and curbing is ill-conceived. Moreover, there is no space between the side of the truck and the edge of dock bay opening to allow for a forklift truck to run off of the edge to cause death or injury to the employee.

Further, this requirement actually would reduce safety for employees in the trucking industry, as providing curbing on dock plates would create a tripping hazard for employees walking on the plates (Ex. 187).

Accordingly, ATA recommended that OSHA revise paragraph (b) to specify:

[C]urbing on dockplates to prevent a vehicle from running off the edge of a ramp or bridging device is not required where there is insufficient space for a vehicle using the device to run off the edge and drop to the ground. Any requirement for curbing on the edges of ramps and bridging devices should be limited to those working environments where a true fall-off hazard exists (Ex. 187).

The Agency agrees with ATA that run-off protection is not necessary when there is insufficient space for equipment to run off the side of the dockboard. Accordingly, OSHA added an exception to final paragraph (b)(1) specifying that employers do not have to use dockboards equipped with run-off guards if there is no fall hazard to guard against. This exception is consistent with MH14.1–1987, MH30.1–2007, and MH30.2–2005, which only require run-off guards when the opening the dockboard bridges exceeds 36 inches (MH14.1–1987 (Sections 3.2(a), 3.4(c), 3.5, 3.6) and MH30.2–2005 (Section 6.1.4)). Unlike the national consensus standards, final paragraph (b)(1) does not specify what size of opening on the dockboard constitutes a run-off hazard. In some circumstances, an opening of less than 36 inches may pose a fall hazard. As such, OSHA believes the most effective way to determine whether a hazard exists is for employers to evaluate whether a particular opening poses a hazard, including considering factors such as the type and size of transfer vehicle the worker is using.

Paragraph (c) of the final rule, like existing § 1910.30(a) and the proposed rule, requires employers to secure portable dockboards by anchoring them in place or using equipment or devices to prevent the dockboard from moving out of a safe position. The final rule also specifies that, when the employer can demonstrate that it is not feasible to

secure the dockboard, the employer must ensure that there is sufficient contact between the dockboard and the surface to prevent the dockboard from moving out of a safe position.

OSHA believes this provision is necessary to protect workers from injury or death. If the employer does not securely anchor the dockboard or equip it with a device that prevents movement, it could slide or drop off of the loading platform or transport vehicle, and the worker could fall. Workers also could fall if the dockboard moves or slides while they are on it. In addition, failure to secure a dockboard could expose workers to crush or caught-in hazards if the dockboard moves, and pins or strikes the worker, or causes the load the worker is moving to shift or fall against the worker.

Final paragraph (c) is consistent with B56.1–2012. That standard also requires anchoring or equipping portable dockboards with devices that prevent the dockboards from slipping (Section 4.13.2). B56.1–2012 does not include any requirements for employers to follow when anchoring or equipping portable dockboards from slipping is not feasible. It does require, like final paragraph (c), dockboards of all types be designed and maintained so the ends have “substantial contact” with the dock and transport vehicle to prevent the dockboard from “rocking or sliding” (Section 4.13.5). Similarly, MH14.1–1987 (Section 3.7(b)), MH30.1–2007 (Section 5.1.7), and MH30.2–2005 (Section 6.2.2) require at least 4-inch overlap between the edge of a dockboard and the edge of the supporting surface (e.g., dock, platform, trailer track bed). OSHA did not incorporate a specific minimum overlap in the final rule because it believes that what constitutes an adequate overlap may involve a number of factors that employers need to determine on a case-by-case basis. OSHA did not receive any comments on proposed paragraph (c) and finalized the paragraph as discussed.

Final paragraph (d), like the proposed rule, requires that employers provide and use measures (e.g., wheel chocks, sand shoes) to prevent transport vehicles from moving while dockboards are in place and workers are using them. OSHA believes it is necessary to prevent transport vehicles from moving in order to protect workers from falling when they work on dockboards. If a transport vehicle moves when a worker is on the dockboard, the sudden movement may cause the worker to fall off the dockboard or the dockboard may be displaced and fall to the ground along with the worker.

The proposed and final rules expand the existing rule (§ 1910.30(a)(5)), which only requires that employers prevent “rail cars” from moving when workers are using dockboards to load/unload cargo. However, workers also are exposed to fall hazards when they use dockboards to load/unload other types of transport vehicles. As a result, OSHA expanded the existing rule to ensure that workers are protected whenever they use dockboards, regardless of the type of transport vehicle workers are loading/unloading.

The final rule gives employers flexibility in selecting measures to prevent the transport vehicle from moving. Employers must ensure whatever measures they use are effective in preventing movement, regardless of the type of transport vehicle the employer is loading/unloading. For example, for wheel chocks, which are one of the most frequently used measures to prevent transport vehicles from moving, the size of the transport vehicle wheel determines the size of the wheel chock that will be effective to prevent the vehicle from moving.

OSHA received one comment on the proposed rule. ATA said the requirement is both unnecessary and conflicts with section (4)(b)(1) of the OSH Act (29 U.S.C. 653(b)(1)):

FMCSA’s [Federal Motor Carrier Safety Administration] brake regulations address this condition and preclude OSHA’s wheel chocking requirements. Jurisdiction in this matter was asserted in a 2001 letter from then FMCSA Acting Deputy Administrator Julie Cirillo to OSHA officials. The letter clearly asserts FMCSA’s exclusive jurisdiction over the immobilization of parked vehicles in stating that FMCSA’s parking brake regulations were “written specifically to protect truck drivers and anyone else who might be injured by inadvertent movement of a parked commercial motor vehicle.” . . . We believe [FMCSA] brake regulations constitute an ‘exercise of statutory authority’ to prescribe or enforce standards or regulations affecting occupational safety or health (Ex. 187).

Department of Transportation (DOT) regulates interstate transportation of “commercial motor vehicles” (CMV) traveling on public roads, thus, pursuant to section 4(b)(1) of the OSH Act, OSHA is preempted. DOT regulations define a CMV, in part, as a self-propelled or towed vehicle used on the highways in interstate commerce, if the vehicle:

- Has a gross vehicle weight rating or gross vehicle weight of at least 10,001 pounds, whichever is greater; or
- Is used in transporting materials found by the Secretary of Transportation to be hazardous as defined by DOT

regulations and transported in a quantity requiring placarding under DOT regulations (49 U.S.C. 31132).

DOT regulations do not apply to transport vehicles that do not meet the definition of CMV, do not operate in interstate transportation, or are not used on public roads. OSHA continues to have authority over:

- Transport vehicles that do not meet the definition of CMV; and
- CMVs not operated in interstate commerce, which includes CMVs that transport materials on private roads or within a work establishment.

OSHA has the authority to enforce chocking requirements in these situations, which the Agency outlined in two letters of interpretation (Letter to Mr. Turner, November 8, 2005³⁰ and letter to Mr. Cole, March 7, 2011³¹). Thus, to the extent that FMCSA covers the specific vehicle, final paragraph (d) does not apply. That said, OSHA believes final paragraph (d) is necessary because not all transport vehicles are CMVs or used on public roads. Employers use transport vehicles to move material and equipment within their facilities. In addition, most transport vehicles are loaded and unloaded off public roads. Therefore, OSHA adopted proposed paragraph (d) with editorial revisions.

Final paragraph (e), like existing § 1910.30(a)(4) and the proposed rule, requires that employers equip portable dockboards with handholds or other means that permit workers to safely handle the dockboard. Handholds and other means of gripping are necessary so workers are able to move and place dockboards without injuring themselves or others. If workers cannot handle or grip a dockboard safely, they could drop it on their feet, crush their fingers while putting the dockboard into place, or fall. Handholds also make it possible to place dockboards into the proper position (e.g., adequate overlap, secure position) so the dockboards will be safe for workers to use.

Final paragraph (e) is essentially the same as existing § 1910.30(a)(4) and is consistent with B56.1–2012 (Section 4.13.3), MH14.1–1987 (Section 3.2.(b)), MH30.1–2007 (Section 5.2.1), and MH30.2–2005 (Section 6.1.6). OSHA notes that these national consensus standards also specify that, when handling a portable dockboard

³⁰ OSHA letter to Mr. Turner available at: http://www.osha.gov/pls/oshaweb/owadisp.show_document?p_table=INTERPRETATIONS&p_id=25161.

³¹ OSHA letter to Mr. Cole available at: http://www.osha.gov/pls/oshaweb/owadisp.show_document?p_table=INTERPRETATIONS&p_id=28121.

mechanically, employers must provide forklift loops, lugs, or other effective means to move or place the dockboard. There were no comments on the provision and OSHA adopted the provision with minor editorial revisions.

Section 1910.27—Scaffolds and Rope Descent Systems

Final § 1910.27, like the proposed rule, addresses scaffolds and rope descent systems (RDS) used in general industry. The purpose of § 1910.27 is to protect workers whose duties require them to work at elevation, whether on scaffolds or RDS. The existing standards (§§ 1910.28 and 1910.29) address scaffolds, but not RDS. Prior to the final rule, OSHA regulated the use of RDS under the general duty clause (29 U.S.C. 654(a)(1)) and through written policy statements that established minimum expectations for employers who use RDS.

For two reasons, OSHA divided the final rule into separate paragraphs for scaffolds and RDS. First, the record shows that the hazards involved in working on scaffolds are different from the hazards associated with using an RDS (Exs. 66; 122; 221). Second, based on comments received in the record, OSHA believes that the final rule should not regulate RDS as a type of suspended scaffold. Uniformly, commenters said RDS are not suspended scaffolds (Exs. 122; 163; 205). For example, Mr. Matt Adams, with Rescue Response Gear, stated: “Rope descent systems are described in this document as representing a variation of the single-point adjustable suspension scaffold. This is a terribly antiquated view of what rope work really is, and does not adequately acknowledge the extreme versatility and safety record of rope access” (Ex. 122). The Society of Professional Access Technicians (SPRAT) had similar concerns, noting:

Permitting rope descent systems to be regulated as suspended scaffolds is potentially hazardous in that this does not adequately address the versatility, safety, and training required to achieve safety while working suspended on rope. The hazards associated with suspended scaffolds do not in any way emulate the hazards associated with roped access work, and as a result the mitigation measures, training, and equipment requirements also differ (Ex. 205).

For the reasons discussed above, OSHA also revised the title of this section of the final rule to “Scaffolds and Rope Descent Systems” from the proposed “Scaffolds (including rope descent systems).” OSHA agrees with commenters that the proposed title may mistakenly imply that RDS are a type of

scaffold (Exs. 122; 221). The only purpose of the proposed title was to indicate that RDS, like scaffolds, involve working at elevated work locations.

OSHA notes that a number of stakeholders who commented on various provisions of proposed § 1910.27 submitted almost identical comments. OSHA does not cite to all of these comments when discussing each provision of the final rule. Instead, OSHA cites to samplings of those comments when addressing an issue.

OSHA drew the rope descent system requirements in the final rule from the following sources:

- 1991 OSHA memorandum to regional administrators allowing the use of RDS when employers follow all of the provisions outlined therein (Ex. OSHA-S029-2006-0062-0019);
- American National Standards Institute/American Society of Safety Engineers ANSI/ASSE Z359.4-2012 Safety Requirements for Assisted-Rescue and Self-Rescue Systems, Subsystems and Components (ANSI/ASSE Z359.4-2012) (Ex. 387); and
- American National Standards Institute/International Window Cleaning Association I-14.1-2001—Window Cleaning Safety (I-14.1-2001) (Ex. 14).³²

Paragraph (a)—Scaffolds

Final paragraph (a), like the proposed rule, requires that employers ensure scaffolds used in general industry meet the requirements in the construction scaffold standards (29 CFR 1926, subpart L (Scaffolds)), and, as a result, the final rule deletes the existing general industry scaffold requirements (existing

³² After the rulemaking record was closed and certified on June 13, 2011, ANSI administratively withdrew ANSI/IWCA I-14.1-2001, Window Cleaning Safety, on October 23, 2011, because the standard had not been revised or reaffirmed by the deadline required. ANSI Essential Requirements (www.ansi.org/essentialrequirements) specify all that ANSI national consensus standard must be revised or reaffirmed within 10 years from their approval as an American National Standard or the standard is automatically withdrawn (Section 4.7 Maintenance of American National Standards).

SEIU Local 32BJ objected to OSHA’s reliance on I-14.1-2001, arguing that the ANSI/IWCA I-14 committee did not operate by consensus and misrepresented votes (Ex. 316, 324, Ex. 329 (1/19/2011), pgs. 5–8). The Local submitted a number of documents purportedly substantiating this claim (see Ex. 316–320). However, ANSI has due process requirements that standards developers must follow. Because the I-14 committee was accredited by ANSI and the I-14.1-2001 standard was approved by ANSI, OSHA presumes those requirements were followed. ANSI’s requirements include procedures for dealing with the sort of objections Local 32BJ has made, and nothing in these documents show that Local 32BJ presented its claims to ANSI, through an appeal or otherwise. OSHA is unable to ascertain from the Local’s documents that the I-14 committee did not follow the ANSI rules.

§§ 1910.28 and 1910.29). The construction scaffold standards, which OSHA updated on August 30, 1996 (61 FR 46104; 61 FR 46107; 61 FR 46116)), are more current than the general industry standards, which OSHA first adopted in 1974 (39 FR 23502), and last updated in 1988 (53 FR 12121 (4/12/1988)).

The final rule, similar to the proposed and construction scaffold rules, defines scaffold as a “temporary elevated or suspended platform and its supporting structure, including anchorage points, used to support employees, equipment, materials, and other items” (§ 1910.21(b)). For the purposes of final subpart D, scaffolds do not include crane-suspended or derrick-suspended personnel platforms or RDS. OSHA’s standard on powered platforms for building maintenance (§ 1910.66) addresses personnel platforms used in general industry.

Commenters supported making OSHA’s general industry and construction standards consistent. For example, Mr. Bill Kojola with the AFL-CIO, said: “We believe that it is important to have consistent standards that address scaffolds so that all workers, regardless of the industry in which they work, have equal or equivalent protection from the hazards that are associated with scaffolds” (Ex. 172). At the hearing on the proposed rule, Mr. Kojola added:

OSHA is proposing that general industry comply with the construction industry’s scaffold standards in 29 CFR 1926(L). . . . By requiring employers in general industry to comply with the construction scaffold standards, consistency will be achieved as well as a decrease in any confusion that . . . would likely arise if the two standards were different between these two industries (Ex. 329 (1/20/2011, p. 222)).

Mr. Mark Damon, president of Damon, Inc., observed: “My experience is that people in general industry are sometimes involved in the erection of scaffolds. I believe . . . similar protection should be afforded to workers in general industry” (Ex. 251).

OSHA believes that the final rule will ensure consistent application of the general industry and construction standards, and increase understanding of, and compliance with, the final rule by employers who perform both general industry and construction work. The record indicates that many general industry employers who use scaffolds also perform construction work on scaffolds; therefore, they already are familiar with the construction scaffolds standards. OSHA believes that having those employers comply with a single set of requirements will facilitate

compliance and, thus, provide greater worker protection. In addition, these employers will not have to change their current practices to meet the requirements of the final rule. OSHA also believes that other general industry employers should not have difficulty complying with the final rule. The construction scaffolding standards include all 21 types of scaffolds the existing general industry standards regulate. Therefore, OSHA finalizes paragraph (a) as discussed.

Paragraph (b)—Rope Descent Systems

Final paragraph (b), similar to the proposed rule, establishes requirements for rope descent systems (RDS) when employers use them. The final rule defines an RDS as a “suspension system that supports an employee in a chair (seat board) and allows the employee to descend in a controlled manner and, as needed, stop at any point during the descent” (§ 1910.21(b)). An RDS, sometimes referred to as controlled descent equipment or apparatus, usually consists of a roof anchorage, support rope, descent device, carabiner(s) or shackle(s), and a chair (seat board) (§ 1910.21(b)). The final rule definition also expressly states that an RDS does not include industrial rope access systems.

The use of RDS is prevalent in the United States today. Employers frequently use RDS in building cleaning (including window cleaning), maintenance, and inspection operations. As far back as 1990, OSHA noted that, according to some estimates, 60 percent of all window cleaning operations used RDS (55 FR 92226). In 2010, Valcourt Building Services (Valcourt) stated that about 70 percent of all window cleaning operations in high-rise buildings in the United States used RDS (Ex. 147).

OSHA’s existing general industry and construction standards do not address the use of RDS.³³ In the 1990 proposed rule, OSHA requested comments on whether OSHA should allow or prohibit the use of RDS (55 FR 29224, 29226 (7/18/1990)). Although OSHA did not finalize the 1990 proposal, in 1991 the Agency issued a memorandum allowing the use of RDS when employers follow all of the provisions outlined in that memorandum (hereafter, “1991 RDS memorandum”) (Ex. OSHA–S029–0662–0019).³⁴

The 1991 RDS memorandum specified that employers must use RDS

in accordance with the instruction, warnings, and design limitations that the manufacturer or distributor sets. In addition, the 1991 RDS memorandum specified that employers must implement procedures and precautions including employee training; equipment inspection; proper rigging; separate fall arrest systems; equipment strength requirements; prompt employee rescue; padding of ropes; and stabilization. OSHA based the proposed rule on the provisions in the 1991 RDS memorandum. OSHA notes that the International Window Cleaning Association (IWCA) also based its standard, ANSI/IWCA I–14.1–2001—Window Cleaning Safety (I–14.1–2001), on the 1991 RDS memorandum. Commenters overwhelmingly supported, and already comply with, the requirements in that memorandum and I–14.1–2001 (Exs. 138; 147; 163; 184; 221; 242).

OSHA received many comments on RDS, most of which supported allowing employers to use those systems (Exs. 138; 151; 153; 205; 219; 221; 222; 227; 241; 243). First, many commenters said RDS are safe and, as a number of commenters claimed, safer than using suspended scaffolding (Exs. 163; 184; 221; 227; 242; 243; 329 (1/19/2011, pgs. 326–329)). Mr. Stephan Bright, with IWCA and chair of the I–14.1 committee, said that RDS are safe, particularly when used in accordance with the I–14.1–2001 standard, which has established “accepted safe practices” for using RDS (Ex. 329 (1/19/2011, p. 466)). He also indicated that OSHA must believe RDS are safe to use because the Agency “has been referencing this standard since its publication and has used this standard as a guideline to enforce rope descent system safety in over 100 citations against window cleaning contractors in the last 10 years” (Ex. 329 (1/19/2011, p. 466)). Mr. Bright said that the decreases in injuries and fatalities associated with RDS use since the IWCA issued the I–14.1–2001 standard “clearly reveal that RDS is a safe and viable means to use when the eight provisions of OSHA’s memorandum and the I–14 Standard are met. Enforcement of the same by OSHA only increases the level of safety” (Ex. 329 (1/19/2011, p. 467)).

Mr. Sam Terry, owner and president of Sparkling Clean Window Company (Sparkling Clean), said his analysis of more than 350 incidents (125 involving window cleaning) showed that RDS are safer than suspended scaffolding (Exs. 163; 329 (1/19/2011, pgs. 326–329)). In particular, he said the analysis indicated that the RDS provisions of the proposed

rule would prevent almost every RDS incident, while more than 80 percent of the suspended scaffolding incidents resulted from equipment failure that was “beyond the control” of the employer or workers using the equipment (Exs. 163; 329 (1/19/2011, pgs. 326–329)).

Commenters also said RDS are safer than suspended scaffolds because they said RDS do not involve the “ergonomic consequences” that suspended scaffolding does (Exs. 163; 184; 221; 242). These commenters pointed out that, in many cases, moving and assembling suspended scaffolding components requires lifting heavy weights, such as davit masts (weighing up to 160 pounds), davit bases (weighing up to 145 pounds), and davit booms (weighing up to 98 pounds).

Second, some commenters supported allowing RDS because RDS give employers greater control over the safety of workers and the public than suspended scaffolding (Exs. 163; 227; 243). With regard to worker safety, Mr. Terry said workers using RDS are able to descend to the ground or “get themselves and their equipment out of harm’s way” more quickly than workers using suspended scaffolding (Exs. 163). Commenters said this advantage is particularly important if sudden or unexpected dangerous weather hazards appear (Exs. 138; 163; 184; 221; 242). Sparkling Clean said:

[A] worker can stop and be on the ground in a matter of minutes . . . [O]f the 65 incidents and 31 fatalities which occurred by users of RDS in the window cleaning industry since 1995, not one occurred as a result of . . . using the equipment during wind gusts, micro bursts or tunneling wind currents (Ex. 163).

Moreover, Sparkling Clean maintained that the adverse weather does not affect using RDS any more than using suspended scaffolding (Ex. 163).

With regard to protecting the safety of the public and other workers on the ground, commenters indicated that RDS are safer because suspended scaffolding requires assembling components, often done on narrow ledges without fall protection, and these components could fall and strike individuals below (Exs. 163; 184; 221; 242).

Third, commenters supported allowing employers to use RDS because acceptance of RDS increased over the last 20 years since OSHA issued the 1991 RDS memorandum and the IWCA adopted its I–14.1 standard, which addresses RDS (Ex. 147). As noted earlier, Mr. Bruce Lapham, of Valcourt, mentioned that, nationally, about 70 percent of all window cleaning operations in high-rise buildings use

³³ The existing general industry rule only covers boatswain’s chairs (29 CFR 1910.28(f)).

³⁴ 1991 RDS Memorandum is available from OSHA’s Web site at: http://www.osha.gov/pls/oshaweb/owadisp.show_document?p_table=INTERPRETATIONS&p_id=22722.

RDS (Ex. 147). IWCA also said that the use of RDS by their member companies has grown since it issued the I-14.1-2001 standard (Ex. 329 (1/19/2011, p. 483)). Mr. Lapham said that, although the IWCA standard made window cleaning safer, he had concerns that without “clear cut regulations” on RDS, misuse of that equipment could occur (Ex. 147).

Finally, several commenters urged OSHA to allow employers to use RDS because they are less expensive than suspended scaffolding (Exs. 163; 184; 221; 242). Some commenters said that using suspended scaffolding can cost as much as 30 percent more than using RDS (Ex. 329 (1/19/2011, pgs. 209, 314)). Other commenters said using RDS was less costly even if the building has an existing suspended scaffold system (Exs. 163; 184; 221; 242). Mr. Terry explained:

The time involved in setting up a powered platform system and riding the scaffold up and down at 30 feet per minute is typically much slower than using [RDS]. The largest cost we incur in providing our services is labor by a significant percentage. Therefore, in many cases, it is actually less expensive to access the side of the building using [RDS] . . . (Ex. 163).

Commenters also said OSHA should allow employers to use RDS even if the design of the building or structure permits the use of other means and methods to perform window cleaning or other maintenance activities (Exs. 163; 184; 221; 242).

OSHA notes that many commenters provided support for the use of RDS, saying that OSHA should allow employers to use RDS, but only if employers follow all of the provisions in OSHA’s 1991 RDS memorandum, as well as those in I-14.1-2001, including the 300-foot RDS height limit (Exs. 138; 147; 215; 245; 331).

A number of commenters, primarily workers and worker organizations, opposed allowing employers to use RDS (Exs. 311; 313; 316; 329 (1/19/2011, pgs. 5-8, 17-19)); 329 (1/20/2011, p. 222)). For example, the Service Employees International Union (SEIU) Local 32BJ members opposed allowing RDS because they said RDS were not safe (Exs. 224; 311; 313; 316; Ex. 329 (1/19/2011, pgs. 5-8)). At the hearing, Mr. John Stager, former SEIU Local 32BJ president, said:

I wonder whether OSHA has seriously studied the hazards and evaluated the history of this rulemaking; and if so, I do not understand how OSHA could have decided that unrestricted use of RDS is compatible with OSHA’s mission of adopting fully protective safety standards. I understand that OSHA’s [1991 RDS memorandum] was much

less than a fully protective standard; rather, it was the way that OSHA deals with hazards for which no standards exist. We disagreed with the terms of the [1991 RDS memorandum] then, and still do today But, to incorporate the terms of [the 1991 RDS memorandum], or terms like them, in a permanent standard is completely inadequate and flawed. In fact, it flies in the face of the Supreme Court’s decision that OSHA must place pre-eminent value on assuring employees a safe and healthful working environment limited only by the feasibility of achieving such an environment (Ex. 329 (1/19/2011, pgs. 5-6)).

Mr. McEneaney, another SEIU Local 32BJ member, added:

My comparisons and recommendations will ultimately show that even if these proposed safety standards are adopted, controlled descent devices cannot adequately ensure worker safety to the same extent as scaffolding. A major difference between scaffolding and rope descent systems is the type of rope used. The wire rope utilized in scaffolds is never subject to failure due to abrasions; unlike RDS ropes that are constantly at risk of abrasion once it goes past the entry point. There was also no reliable mechanism for protecting RDS rope from abrasion points between the point of entry and the ground; for example, cornices and signs, et cetera (Ex. 329 (1/19/2011, pgs. 17-19)).

Mr. Jesus Rosario, a SEIU Local 32BJ member, and window cleaner since 1989, called RDS “a very dangerous system” (Ex. 311). He explained his personal experience with RDS as a way to substantiate his contention:

The protection gap [for RDS] increases with the length of the rope. The more rope, the more movement. The wind can push you around much more [when using an RDS rather than suspended scaffolding]. When I was about 10 stories, I have swayed as much as 3 windows apart from sudden wind. And I have been pushed by the wind when I was as little as 5 or 6 stories down.

Once, I was working by myself, and the rope below me got caught in a fan. I had to climb down the lifeline rope to get out of the [RDS]—about three stories. . . . Entry over the side [of the roof] is very dangerous. Sometimes, I have even had to jump with my chair to the edge of the building, and then over the side, which could crack the chair (Ex. 311).

Mr. Rosario summed up:

Please do not allow the contractors and the building owners to use RDS. Sure, sometimes there will be places where you just cannot hang a scaffold. But if there is any way to safely hang a scaffold, it is so much safer that there is no good reason to allow [RDS]. I know it’s cheaper for the building owner. But so what—isn’t my life worth something too (Ex. 311)?

Mr. Hector Figueroa, SEIU Local 32BJ secretary-treasurer, mentioned the New York regulation prohibiting RDS use on buildings above 75 feet as the best proof

that RDS are dangerous, and that OSHA should not allow their use (Ex. 224). SEIU also urged that federal OSHA allow the New York regulation to continue without federal preemption, because they believed it is far more protective than the proposed standard. (See the discussion of the preemption issue in the Federalism section.)

OSHA disagrees with Local 32BJ, and has decided against banning all RDS use. The record shows that RDS is a useful method of accessing the sides of building and necessary, at least in certain circumstances. Further, the record shows that RDS use can be conducted safely if proper precautions are followed.

For more than 20 years OSHA has permitted employers to use RDS, provided that employers follow all of the requirements in the 1991 RDS memorandum. Stefan Bright, with IWCA, provided evidence supporting the inference that the 1991 RDS memorandum protects workers:

A survey of IWCA membership was conducted in 1996 and it revealed the following facts: . . . that approximately 800 systems were being used on a day to day basis with an average of 8,000 descents a day and over the course of that nine-month season, which fluctuates because [in] the warmer states, it’s 12 months, the states like here in the North are about nine, 800 workers performed 1,584,000 descents in 1996. In 1996, there was one fatality by a window cleaner using a rope descent system.

In 1991, OSHA published the infamous eight-step RDS memorandum. In the six years prior to this publication, 1985 to 1991, there were 19 fatalities by window cleaners using RDS to perform an estimated nine million descents using the previous information. In the six years after the memorandum was published, 1991 to 1996, only 11 fatalities occurred when window cleaners were using RDS to perform the same number of descents. So that was a significant drop, almost 50 percent reduction (Ex. 329 (1/19/2011, pgs. 463-465)).

Further, as discussed in the FEA, OSHA conducted an analysis of 36 incidents in which one or more deaths were caused by a fall from an RDS between 1995 and 2001. It found that all of the 21 of these incidents caused by the mishandling or malfunction of RDS system or lifelines would be prevented by compliance with one or more provisions of the final rule. OSHA is not aware of any fatalities involving RDS that have occurred when all of the requirements of the final rule were followed.

The final rule incorporates all of the requirements in the 1991 RDS memorandum. In addition, the final rule adopts additional requirements, including anchorage requirements, a 300-foot RDS height limit, prohibition

on RDS use in hazardous weather, securing equipment, and protecting ropes from hazardous exposures. OSHA believes these requirements enhance the protection of workers provided by the 1991 RDS memorandum. Moreover, OSHA believes that the additional protections address a number of the safety concerns SEIU Local 32BJ raised. Accordingly, the final rule continues to allow the use of RDS for suspended work that is not greater than 300 feet above grade.

In the final rule, OSHA added language to the definition of RDS expressly specifying that RDS do not include industrial rope access systems (IRAS) (§ 1910.21(b)). As such, final § 1910.27 does not cover or apply to IRAS. However, other sections of the final rule, including § 1910.28, do cover IRAS.

OSHA agrees with commenters who said IRAS and RDS are different (Exs. 69; 129; 205). For example, Ms. Loui McCurley, of SPRAT, said:

I would like to point out that rope access is not the same thing as controlled descent, rope descent systems, any other big bucket that you might want to put it in. Rope access systems and rope access technicians vary greatly from just a controlled descent or a rope descent system (Ex. 329 (1/19/2011, pgs. 135–138)).

Commenters also pointed out other differences between the two systems. Global Ascent said that IRAS use a two-rope system (Ex. 129). They stated the two-rope system consists of a working line and a safety line, whereas RDS use only a working line (Ex. 129). Accordingly, Global Ascent noted that IRAS have built-in fall arrest by virtue of the dual-ropes (Ex. 129). Several commenters also said that the training requirements necessary for IRAS use and RDS use are much different (Exs. 78; 129; 205). They also said IRAS users need more training than RDS users. Based on these comments, OSHA concluded that IRAS differ significantly from RDS and did not include them in the RDS requirements in final § 1910.27(b).

Final paragraph (b)(1) adds new requirements for anchorages to secure RDS. The final rule defines anchorage as a secure point of attachment for equipment such as lifelines, lanyards, deceleration devices, and rope descent systems (final § 1910.21(b)). The proposal would have required that employers use “sound anchorages,” and OSHA noted that they are “essential to the safety of RDS” (proposed § 1910.27(b)(2)(iv); 75 FR 28866). OSHA also noted that the 1991 RDS memorandum required that employers rig RDS properly, including having

“sound anchorages” (75 FR 28869). Although the proposed rule did not include specific requirements on anchorages for RDS, proposed § 1910.140(c)(12) contained a requirement for a separate anchorage for personal fall arrest systems. The Agency requested comment on whether its proposed approach was sufficient to ensure the safety of anchorages.

OSHA also noted in the proposed rule that the Agency raised the issue of anchorages, and also requested comments in the 1990 proposal (55 FR 29224 (7/18/1990)). At that time, IWCA and window cleaning companies told OSHA that there often were no anchorages on building rooftops (75 FR 28869; OSHA–S041–2006–0666–0543; OSHA–S041–2006–0666–1252; OSHA–S041–2006–0666–1253). Since the companies did not own or have control over the building, they had no control over whether or where building owners would place anchorages. Therefore, they urged OSHA to require building owners to install anchorages and test, inspect, maintain, and certify that the anchorages are capable of holding the RDS, worker, and all equipment. As noted, OSHA did not finalize the 1990 proposed rule.

Today, OSHA continues to believe anchorage requirements are necessary because, as the Final Economic Analysis indicates, anchorage failure is one of the primary causes of window cleaning accidents involving RDS. Data that Mr. Terry, president of Sparkling Clean, compiled and analyzed also showed that lack of sound anchorages accounted for 65 (more than 50 percent) of the 125 window cleaning incidents involving RDS (Ex. 163). Mr. Stefan Bright, with the IWCA, said their analysis of window cleaning fatalities revealed that 95 percent were due to lack of sound anchorages (Ex. 329 (1/19/2011, p. 465)). In addition, commenters uniformly supported adding specific requirements on anchorages to the final rule (Exs. 163; 184; 221; 242).

Final paragraph (b)(1)(i) requires that, before the employer uses any rope descent system, the building owner informs the employer in writing that the building owner has identified, tested, certified, and maintained each anchorage so it is capable of supporting at least 5,000 pounds in any direction, for each worker attached. The final rule also requires that the building owner base the information provided to the employer on:

- An annual inspection; and
- A certification of each anchorage, as necessary, and at least every 10 years.

The building owner must ensure that a “qualified” person conducts both the

inspection and certification. The final rule defines qualified as a person who, by possession of a recognized degree, certificate, or professional standing, or who by extensive knowledge, training, and experience has successfully demonstrated the ability to solve or resolve problems relating to the subject matter, the work, or the project (§ 1910.21(b)).

For the purposes of final paragraph (b)(1)(i), the term “as necessary” means when the building owner knows or has reason to believe that recertification of the anchorage is needed. The final rule gives building owners flexibility in determining when anchorage recertification is necessary. Factors or conditions indicating that recertification may be necessary include, but are not limited to, an accident involving a worker using an RDS, a report of damage to the anchorage, major alteration to the building, exposure of the anchorage to destructive industrial substances, and location of the building in an area of high rainfall or exposure to sea air and humidity that might accelerate corrosion.

OSHA requested comment on adding more provisions ensuring the safety of anchorages in the final rule. In particular, the Agency asked whether it should adopt the information disclosure requirements of § 1910.66.

- Paragraph (c)(1) of § 1910.66 requires that building owners of new installations inform employers in writing that installations meet the requirements of paragraphs (e)(1) and (f)(1) of that section and additional design criteria contained in the other provisions of paragraphs (e) and (f).
- Paragraph (c)(2) of § 1910.66 requires that building owners base the information required in paragraph (c)(1) on the results of a field test of the installation before being placed into service and following any major alteration to an existing installation, and on all other relevant available information, including, but not limited to, test data, equipment specification, and verification by a registered professional engineer.

- Paragraph (c)(3) of § 1910.66 requires that building owners of all installations, new and existing, inform employers in writing that the installation has been inspected, tested, and maintained in compliance with the requirements of paragraphs (g) (inspection, tests, and certification) and (h) (maintenance) of the section and that all protection anchorages meet the requirements of paragraph (I)(c)(10) of appendix C (fall protection anchorages must be capable of supporting 5,000 pounds).

Paragraph (e) of that rule specifies that structural supports, tie-downs, tie-in guides and affected parts of the building included in the installation shall be designed by or under the direction of a registered professional engineer experienced in such design (§ 1910.66(e)(1)(i)).

In addition, the I-14.1-2001 standard requires that building owners provide window cleaning contractors with the following written information:

- The installation or structure has been inspected, tested and maintained in compliance with the requirements of I-14.1-2001;
- All equipment dedicated to the building meets the requirements in Part B (*i.e.*, equipment and building design requirements, such as the requirement that anchorages support a 5,000 pound load in any direction (9.1.11) and that certifications and re-certifications of anchorages be conducted under the supervision of a registered professional engineer (Section 9.1.10);
- Specified load ratings, intended use and limitations to fixtures permanently dedicated to buildings; and
- Manufacturer's instructions for installations, anchorages and fixtures permanently dedicated to the building (Section 1.6.2 (a)-(d)).

Overwhelmingly, commenters supported requiring that building owners identify, test, and maintain anchorages, and certify that those anchorages are capable of supporting 5,000 pounds in each direction for each attached worker.

Many commenters said the anchorage provision is necessary because the lack of "sound anchorages" was the leading cause of fatalities and incidents involving RDS (Exs. 138; 163; 184; 221; 222; 243). Valcourt said:

[W]orkers that use Rope Descent Systems deserve a safe place to work. . . . There is no greater contributing factor to having a safe workplace in which to use an [RDS] than having identified and certified anchorage points in which to tie to. In its 26-year existence, Valcourt has seen both building owners and window cleaners come to a greater understanding of this fact, leading to much safer working conditions (Ex. 147).

Another commenter, 20/20 Window Cleaning of NC, said the new anchorage requirement would prevent accidents and save lives (Ex. 153). IWCA noted that, without the new provision, workers using RDS would not have an equivalent level of protection than do workers who use permanent powered platforms (Ex. 138).

Commenters also said the anchorage requirement is necessary because many building owners do not provide certified anchorages, even though IWCA issued

the I-14.1-2001 standard more than 10 years ago (Exs. 147; 163; 245; 329 (1/19/2011, pgs. 218-219)). Valcourt said about 75 percent of the buildings they service do not have certified anchorages, while LWC Services said less than 5 percent of the buildings they service have them (Exs. 147; 245). LWC Services also estimated that seven percent of mid- and high-rise buildings have certified anchorages (Ex. 245). Finally, LWC Services said their most significant problem is finding anchorage points to allow suspension of equipment, and they questioned how they could install anchorages when they only work at a particular location for a couple of days per year, inferring infeasibility (Ex. 245).

Most commenters said they think permanent anchorages are the responsibility of building owners, and they urged OSHA to require that building owners provide anchorages, and to inspect, test, certify, and maintain them (Exs. 138; 147; 163; 184; 193; 221; 242; 329 (1/19/2011, pgs. 378-388)). Valcourt said OSHA needed to mandate that building owners provide anchorages because building owners will not provide and certify anchorages if it is voluntary:

If OSHA . . . [omits] the requirement of building owners to have their roof anchorage systems initially certified . . . and inspected by a qualified person annually, many building owners will simply state that it is not a requirement of OSHA and not [do it]. This would make the marketplace more dangerous and be a regression of 20 years in window cleaning safety for both the window cleaning and building owner industries (Ex. 147; 329 (1/19/2011, pgs. 378-388)).

Commenters uniformly agreed that OSHA should require that anchorages be capable of supporting 5,000 pounds in all directions for each worker attached, which is consistent with I-14.1-2001 (Section 9.1.1) (Exs. 163; 184; 221; 242; 243). Clean & Polish suggested that OSHA require that anchorages sustain a 5,000 pound load or at least have a 4-to-1 safety factor when using an RDS (Ex. 242). They also supported applying this requirement to tie-backs (Ex. 242).

Commenters were about evenly divided on whether OSHA should codify the language in § 1910.66(c) or the I-14.1-2001 standard. Regarding his support for following the approach in § 1910.66, Mr. Terry, of Sparkling Clean, said:

I agree that building owners should provide employers with the same information required by 1910.66; a certificate of inspection, testing, and maintenance of anchorages for rope access and suspended scaffolding used in building maintenance,

and that an existing certificate for powered platform anchorages would suffice for the same anchorages to be used for rope access. This would allow for rope access to be utilized on buildings with systems or anchorages originally designed for suspended scaffold use without any new requirements or expenses on the building owner (Ex. 329 (1/19/2011, pgs. 224-226)).

Commenters provided recommendations for specific language and items the final requirement on anchorages should contain. For example, Penta Engineering said OSHA should require load testing of all anchorages and davits (Ex. 193). Martin's Window Cleaning (Martin's) said OSHA should require that employers ask for and obtain verification of anchorage certification (Ex. 65).

Several commenters recommended specific timelines for anchorage inspection and certification. Martin's recommended inspections every year, and certifications every 10 years (Ex. 65). Penta Engineering Group agreed, and recommended that OSHA also require anchorage recertification after building owners install new roof systems (Ex. 193).

One commenter urged OSHA to require that building owners ensure qualified persons conduct the annual inspections and certifications (Ex. 204). Other commenters said that professional engineers should perform those tasks (Exs. 65; 193; 329 (1/19/2011, pgs. 378-388)). LJB Inc., noted that it may be a violation of local and state building codes to have anyone other than a professional engineer certify anchorages (Ex. 204). OSHA notes that, under the final provision and the final definition of qualified, building owners are free to use professional engineers to inspect and certify anchorages.

OSHA did not receive any comments opposing an anchorage requirement. OSHA notes that the Building Owners and Managers Association (BOMA) did not submit any comments on the proposed rule or testify at the rulemaking hearing, but they did oppose the requirement in the 1990 proposed rule that building owners provide anchorages. OSHA also notes BOMA was a member of the I-14.1-2001 committee that approved the national consensus standard, which includes anchorage requirements building owners must meet. OSHA agrees with many of the comments and recommendations submitted to the record, and incorporated many of them into the final rule. For example, given that outside contractors generally perform building maintenance (such as window cleaning), and that these

outside contractors usually have no control over the building anchorages and are at particular buildings for only a few days, OSHA determined that inspecting, testing, certifying, and maintaining anchorages and providing information about the anchorages must be the responsibility of building owners. Only when building owners take responsibility for anchorages and provide written information to employers and contractors, can there be adequate assurance that workers will be safe when they use RDS.

Final paragraph (b)(1)(ii) establishes a new provision that requires employers to ensure that no employee uses any anchorage before the employer obtains written information from the building owner that the anchorage meets the requirements of final paragraph (b)(1)(i). In other words, the final rule requires that employers ensure no employee uses an RDS until the employer obtains written information that the building owner identified, tested, certified, and maintained each anchorage so it is capable of supporting at least 5,000 pounds in any direction for each worker attached. The final rule also requires that the employer keep the written information from the building owner for the duration of the job.

OSHA's powered platforms standard contains a requirement similar to the final rule (§ 1910.66(c)(4)). Also, the I-14.1-2001 standard requires that employers (*i.e.*, window cleaning contractors) and building owners not allow suspended work to occur unless the building owner provides, identifies, and certifies anchorages (Section 3.9).

OSHA believes the final rule will ensure that each anchorage to which workers attach an RDS meets the inspection, testing, certification, and maintenance requirements of the final rule before workers attach to it. Under the final rule, employers are not to allow workers to attach to an anchorage and begin work if the employer did not receive written certification that the anchorage is capable of supporting 5,000 pounds. Specifically, final paragraph (b)(1)(ii) prohibits employers, when there are no certified anchorages, from "making do" or attaching RDS to alternative structures, making the assumption that these structures are capable of supporting 5,000 pounds.

OSHA acknowledges that employers currently attach RDS to other structures if there are no certified anchorages available. For example, Mr. Charles Adkins, of Corporate Cleaning Services (Corporate Cleaning), explained what his company does at the 30 to 40 percent of the buildings they service that don't have certified anchorages:

They go up and they select it with the assistance of the foreman who is—we have—we've heard some mention of supervision here and we totally agree that that's a very important fact and that's why we have four salaried foremen, plus an operations manager, who focus exclusively on supervision.

They go up and select them. There are a number of alternatives. They can attach them to the permanent part of the building. They can use parapet clamps if they have a way to properly attach the tieback and the safety line to it and just about every building is different. Sometimes we can use weights to keep them from—to help hold the ropes (Ex. 329 (1/19/2011, pgs. 218–219)).

Finally, OSHA believes that the written information on anchorages that building owners must provide to employers will be helpful for employers throughout the job. Employers can use the information to keep workers continuously informed about which anchorages have proper certification. The information also will be helpful if there are work shift-related changes in personnel, if the employer brings new workers to the job, or if there is a change in site supervisors. Therefore, the final rule is requiring employers to retain the written information on anchorages they obtained from building owners for the duration of the job at that building.

In final paragraph (b)(1)(iii), OSHA provides employers and building owners with additional time to implement the requirements in final paragraphs (b)(1)(i) and (ii). The final rule gives employers and building owners one year from November 18, 2016 to meet the new requirements in final paragraphs (b)(1)(i) and (ii). This means that building owners must identify, inspect, test, certify, and maintain each anchorage by the compliance date.

OSHA believes the additional compliance time is necessary because a number of commenters said most buildings where they use RDS do not have certified anchorages (Exs. 147). For example, Mr. Lapham, of Valcourt, said that their company services 3,850 buildings in 14 states (Ex. 147). Of the buildings Valcourt cleans, Mr. Lapham said almost 75 percent did not have certified anchorages, more than 20 years after OSHA issued the final Powered Platforms standard (§ 1910.66) (Ex. 147).

Mr. Charles Adkins, of Corporate Cleaning Services, the largest window cleaning company in the Chicago area, said that they perform window cleaning services on more than 1,200 buildings (Ex. 329 (1/19/2011, p. 201)). He estimates that about 60 to 70 percent of those buildings already have certified anchorages (Ex. 329 (1/19/2011, pgs. 218–219)).

In the 1990 rulemaking, BOMA objected to requiring building owners to provide anchorages, but agreed that new buildings completed two to five years after the effective date of the final rule should have anchorages (75 FR 28862, 28879; Ex. OSHA-S041-2006-0666-1212).

It is now 24 years since OSHA first proposed a rule addressing RDS, and 23 years since OSHA's 1991 RDS memorandum allowed the use of RDS provided they have "sound anchorages." OSHA does not believe building owners, at this late date, need another two to five years to identify, inspect, test, certify, and maintain anchorages in new or existing buildings. OSHA believes that giving building owners an additional year to meet the requirements of final paragraph (b)(1)(i) is adequate.

Final paragraph (b)(2) establishes RDS design and work-practice requirements that employers must follow to ensure their workers' safety when using an RDS. OSHA drew most of the requirements from the 1991 RDS memorandum and the I-14.1-2001 national consensus standard. Many commenters who supported allowing the use of RDS also supported requiring employers to comply with all of the provisions in the 1991 RDS memorandum and I-14.1-2001 (Exs. 138; 151; 219).

Final paragraph (b)(2)(i), like proposed paragraph (b)(1) and the I-14.1 standard (Section 5.7.12), requires that employers ensure no RDS is used at heights greater than 300 feet (91 m) above grade. The final rule includes two exceptions to the 300-foot height limit, discussed extensively below.

Many stakeholders supported the proposed 300-foot height limit (Exs. 138; 147; 168; 206; 215; 300; 329 (1/19/2011, pgs. 253–254, 401); 329 (1/21/2011, pgs. 98, 474, 477); 331). They said using an RDS at heights above 300 feet was dangerous for workers, and establishing a height limit was an important "safety issue" (Exs. 147; 215). Mr. John Capon, of Valcourt, said, "I think anything above 300 feet is preposterous, to be honest with you. The risks associated with it, just the height, all the conditions, are just overly-dramatic at that height" (Ex. 329 (1/19/2011, p. 401)). Mr. LaRue Coleman, of JOBS Building Services (JOBS), also said worker safety mandated that employers not use RDS over 300 feet, noting: "Contractors will always use the excuse that an area cannot be accessed in any other manner [than RDS] to save the building money. This is a safety issue and should not be left up to an individual employer or

employee to make an onsite decision of this nature” (Ex. 215). Mr. Coleman also suggested that OSHA adopt a height limit of 130 feet, which California OSHA³⁵ uses (Ex. 215). Not only would a 130-foot height limit significantly reduce the dangers to workers who use RDS, but Mr. Coleman said it also would eliminate stabilization issues and requirements (Ex. 215). OSHA notes that the State of California also requires all buildings over 130 feet to be equipped with a powered platform.

Mr. Lapham, of Valcourt, said their experience indicated that the following factors necessitated limiting RDS use to a maximum of 300 feet:

- The significant increased effect of wind at heights above 300 feet;
- The significant increased length and weight of ropes required for using RDS above 300 feet; and
- The increased potential that moving the weightier ropes will “literally pull a window cleaner over the edge of the building” roof (Ex. 147).

Other commenters agreed with Valcourt’s analysis. Ms. Kelley Streeter, of Vertical Access, said ropes longer than 300 feet are heavy and moving or working with such lengths can be hazardous and strenuous for workers (Ex. 329 (1/21/2011, p. 98)). Mr. Brian Gartner, of Weatherguard Service, Inc. (Weatherguard), agreed, and identified additional factors that contributed to the danger of using RDS above 300 feet:

In my opinion, based on testing and evaluation and basic engineering concepts, 300 feet is at the high end of the safe use range. Suspensions over 225 feet start responding to the effects of wind on the ropes and the worker. The longer the rope, the more surface area is exposed to the wind. The wind effect is variable. The lower the worker is from the roof, there is more rope above him or her that can be subjected to the wind, thus the higher the suspension, the more the worker is free to move.

The longer the suspension the greater the “spring” in the suspension and safety ropes. This springiness is in all synthetic ropes that are in the diameter ranges that are used for this purpose whether they are static type ropes or other rope types. There are many other factors that contribute to the dangers of rope descents above 300 feet. For every foot of increased suspension, the dynamics and conditions change and become more problematic (Exs. 329 (1/19/2011, pgs. 253–254); 331).

Mr. Gartner added that there is a marked difference in handling RDS ropes (support and fall arrest) on buildings less than 300 feet compared to buildings above 300 feet: “[T]he differences of how the winds affect [the ropes] and you, on the roof, and the

trouble discerning what is happening with the ropes will speak volumes regarding the safety issues of building height and rope descent” (Ex. 331; see also Ex. 300). For example, he said moving heavier ropes has the potential of pulling workers over the edge of the building (Ex. 147). In conclusion, he stated: “Those that minimize, overlook, or disregard all of these factors, as they are all safety concerns, are not responsibly or realistically addressing the height issue and manifesting a disregard to worker and the public’s safety” (Exs. 329 (1/19/2011, pgs. 253–254); 331).

Some commenters said the 300-foot height limit would not be a burden on most employers. Mr. Gartner said, “The [number] of buildings in the United States taller than 300-feet is miniscule when compared to the [number] of buildings under 300 feet in height” (Ex. 331). Mr. Coleman said that the 300-foot limit would affect only six percent of office buildings in the 19 largest national markets:

If you were to take the study out to additional markets the effect would be even less since smaller/shorter buildings are typically built in these markets. If you were to add schools, hospitals and hotels to a study the effect would be even less since again these types of structures are typically shorter except when located in a major metropolitan area. Of the 6% of buildings over 11 floors the vast majority of them will have either permanent rigging or building owned davits and tie-backs thereby reducing the cost effect of lowering the height (Ex. 215).

Finally, commenters said OSHA should adopt the 300-foot height limit because the I–14.1–2001 national consensus standard requires it. Mr. Lapham, of Valcourt, who was one of the members of I–14.1–2001 committee, said it took “multiple decades” for the industry to agree to the 300-foot limit in the I–14.1–2001 standard, so OSHA should not eliminate it “under any circumstance” (Ex. 147). Mr. Gartner, of Weatherguard, and also a member of the I–14.1–2001 committee, said that Ontario, Canada, also adopted the I–14.1–2001 standard’s 300-foot limit for RDS:

Canada spent much time and money in the establishment of their Code with respect to the height limit of 300 feet.³⁶ They did studies, hired consultants and deliberated at length. Their Code was promulgated due to the high death toll of their window cleaners;

³⁶ The Ontario window cleaning regulation specifies that employers must not use controlled descent devices above 90 meters, which equals 295.276 feet (R.R.O. 1990, Regulation 859 § 28(c)).

they had one fatality a month before the code was enacted (Ex. 331).

Many commenters opposed the proposed 300-foot RDS height limit for various reasons (Exs. 126; 151; 163; 178; 184; 205; 218; 219; 221; 222; 242). Most of those commenters said there was no safety-related reason to impose the height restriction, claiming that using RDS at heights above 300 feet is safe (Exs. 151; 163; 184; 218; 242). Mr. Terry, of Sparkling Clean, said using RDS “at all heights is routinely performed safely [and] successfully . . . in many parts of the country” (Ex. 163). He considered using RDS at any height to be so safe that “I believe the proposed 1910.27(b) should actually read [that using RDS] is encouraged at any height” (Exs. 163; 329 (1/19/2011, p. 330)). He added that OSHA’s final rule also should allow employers to use RDS as a substitute to the means and methods originally designed into the building or structure when the design of the building or structure will safely support the use of the RDS (Ex. 163).

A number of commenters said their injury data also demonstrated that RDS are safe to use at any height. These commenters said that they had no recordable incidents related to using RDS on taller buildings (Exs. 163; 184; 242). Mr. Terry said his analysis of nine RDS incidents that involved RDS use over 300-feet indicated that none of the cases involved the height of the work as the cause of the incident (Ex. 163).

Many commenters said they considered RDS to be safer than powered platforms at any height, including above 300 feet, and, thus, there was no reason for OSHA to impose the 300-foot height limit on their use. For example, Corporate Cleaning said RDS are safer than powered platforms at all heights below 700 feet because they are more maneuverable, and allow workers to descend more quickly in an emergency (Ex. 126).

Other commenters disputed the argument that the effects of wind on RDS used above 300 feet are greater than for suspended scaffolding/powered platforms. Some commenters said there was no difference in the effects of wind on RDS use than on powered platforms at any height (Exs. 163; 205). For instance, Ms. McCurley, of SPRAT, said:

We . . . find that the height restrictions and the wind exposure to be . . . unfounded. In practical living and in practical working, we find that all of these things are a matter of skills, knowledge and good decision-making. If the wind is too high that day, if there is ice out there that day, you just don’t go. And that’s true of whether you are using a scaffold or a powered platform or a ground-based system or whatever. You just have to

³⁵ California Code of Regulations, Title 8 Chapter 4, Subchapter 7 Article 5, § 3286.

make the right decision based on the gear that you are using (Ex. 329 (1/19/2011, p. 154)).

Some commenters who opposed the proposed 300-foot RDS height limit claimed it was “arbitrary.” For instance, Mr. Ken Diebolt, of Vertical Access, said:

My primary objection is to the 300-foot limit . . . [is] it seems to us completely arbitrary. I mean, once you’re X number of feet off the ground, once you’re 10 feet off the ground, 50 feet, 100 feet, it doesn’t really—you’re no safer at 300—at 100 feet than you are at 300 feet or 500 feet if you’re doing the work well. And I wonder where this came from. It comes from the window washing industry but I have no history of that and I don’t know (Ex. 329 (1/21/2011, p. 138)).

Mr. Adkins, of Corporate Cleaning, agreed:

We urge you not to adopt that limitation, especially as it is written in your proposals. . . . It appears to be an arbitrary limit and does not, is not based on any kind of empirical research to determine that there is a problem in fact with the use of ropes in excess of 300 feet. In fact, I haven’t been able to find any evidence of any accidents or any serious incidents where the length of the rope had anything to do with it (Ex. 329 (1/19/2011, p. 204)).

In addition, several commenters disputed there was consensus supporting the RDS height limit. For example, Mr. Adkins said:

[T]here is an implication there’s a consensus in this industry supporting the 300-foot rule. I think a lot of testimony we’ve had here today makes it clear that that is not the case. Not only do I not believe it, not only will you hear from other individuals in the window washing industry who do not support that, you also heard from people on the other side, Mr. Stager from the Union who doesn’t believe there’s been an effective consensus developed on it (Ex. 329 (1/19/2011, pgs. 203–212)).

However, Mr. Bright, chair of the I–14.1–2001 committee, said there was “broad agreement” among the committee to include a 300-foot RDS height limit, which is ANSI’s definition of “consensus” (Ex. 329 (1/19/2011), pgs. 244–46).

Commenters opposing the RDS height restriction also said the IWAC based the I–14.1–2001 requirement more on emotions and economics than on safety (Ex. 163; 184; 221; 222; 241). The comment of Mr. Sam Terry, of Sparkling Clean, was representative of those stakeholders:

It is my contention that the 300’ limitation is based more on the following two issues:

- The emotions of the untrained observer who thinks [RDS] looks scary
- The financial benefit to the manufacturer, designer, installer or equipment associated with suspended

scaffolding and the large window cleaning companies who can limit their competition by restricting the use of the less expensive option of [RDS] (Ex. 163).

Mr. Adkins agreed:

Now like I said, those people worked very hard on it, I don’t dispute that, but the I–14 Committee or 50 percent of them were not window washers. They are from other industries and they are very honest, hard-working people of integrity but they have legitimate business interests to look at enforcing a 300-foot limitation or eliminating it all together and that has to be considered, I am sure (Ex. 329 (1/19/2011, pgs. 203–212)).

Mr. Adkins also said that restricting RDS use would lead to economic hardship for some window cleaning companies and to higher unemployment (Ex. 329 (1/19/2011, p. 220)), but he did not have knowledge of any companies that experienced economic hardship by following the I–14.1–2001 height restriction on RDS use. However, Diamond Window Cleaning said the RDS height limit would give unfair competitive advantage to larger companies that have, and only use, powered platforms or systems installed on buildings (Ex. 219). Some commenters said using RDS is less costly than using powered platforms, and requiring companies to use powered platforms would be costly (Ex. 219). Mr. Terry explained:

Of the buildings in my marketplace, the buildings taller than 300 feet typically do not have permanently-installed powered platforms for access to the exterior of the building. Most of those buildings were designed and built in the last five years and do not have permanently installed powered platforms for access to the exterior of the building (Ex. 163).

After reviewing the rulemaking record, OSHA has decided to retain the proposed requirement that employers not use RDS at heights above 300 feet above grade. OSHA continues to believe that using RDS above 300 feet is hazardous, and that adopting the height limit in the final rule will help protect workers from injury and death.

OSHA agrees with commenters who said that there are many factors that contribute to the dangers of operating RDS above 300 feet. First, as the proposed preamble and commenters discussed, OSHA believes that using RDS at greater heights increases the potential effects of wind (e.g., wind gusts, microbursts, tunneling wind currents) on workers. OSHA believes that, when working at heights over 300 feet, the effects of wind on the RDS and the worker are greater in general, and greater than the effects imposed on heavier powered platforms. OSHA notes that commenters identified incidents in

which workers used RDS in windy weather, and the wind blew the workers around the side of a building and 30 feet away from a building (Exs. 163; 168). Moreover, while OSHA agrees that workers can descend more quickly on RDS if severe weather suddenly occurs, excessively windy weather can buffet workers descending from above 300 feet, causing them to swing great distances during the long descent. Most likely in these situations, workers using RDS will have only intermittent stabilization (*i.e.*, suction cups) so they can swing by the ropes and hit the building or other structures and get seriously injured before they reach the ground.

Second, using RDS above 300 feet requires the use of longer ropes. OSHA said in the proposed rule, and IWCA (Ex. 138) agreed, that the greater the length of rope used for descent, the greater the effect of winds (e.g., wind gusts, microbursts, tunneling wind currents) (*see also* Ex. 300). Longer ropes have a greater possibility of getting tangled or caught on objects, especially in windy (or gusty) weather, leaving the worker unable to descend or self-rescue. The compilation of RDS incidents Mr. Terry submitted included cases in which the ropes got entangled in equipment lines, an antenna, and other workers’ RDS lines, leaving the worker stuck and unable to descend (Ex. 163). These cases arise because, as Mr. Bright testified, employers often have a number of workers (e.g., 5 to 6) descending on the same side of a building at the same time (Ex. 329 (1/19/2011, pgs. 477, 489–490)).

Third, OSHA agrees with Mr. Lapham, of Valcourt, and Ms. Streeter, of Vertical Access, who said that longer ropes needed for RDS use above 300 feet are heavier, and moving them can be hazardous (Ex. 147; 329 (1/21/2011, p. 98)). Taken together, OSHA finds convincing the arguments that workers are at an increased risk of harm when using RDS over 300 feet, and that the RDS height limit in the final rule is necessary to protect them.

OSHA also retained the RDS height limit in the final rule because the I–14.1–2001 national consensus standard included the same limit. The American National Standards Institute (ANSI) approved the I–14.1–2001 standard, and industry widely uses it. OSHA believes the national consensus standard reflects industry best practices. Commenters, including some who were members of the I–14.1 committee, said there was broad agreement to include the 300-foot RDS height limit in the I–14.1 standard (Ex. 147; 329 (1/19/2011, pgs. 210–211, 253, 267–268)).

Since IWCA issued the I-14.1-2001 standard, several jurisdictions have adopted the 300-foot RDS height limit. Minnesota (5205.0730, Subpart 6(A)) and Washington (WAC-296-878-20005) issued regulations limiting RDS use to 300 feet, while California now limits RDS use to 130 feet (Cal. Code Regs., Tit. 8, § 3286 (2012)). Additionally, OSHA believes the experience of Canada (Ontario province) deserves consideration (R.R.O. 1990, Regulation 859). According to Mr. Brian Gartner, of Weatherguard Service, who was a member of the I-14.1 committee:

Canada invested much time and money in the establishment of their code with respect to the height limit of 300 feet. They did studies, hired consultants, and deliberated at length. Their code was promulgated due to the high death toll of their window cleaners. They had one fatality a month before the code was enacted (Ex. 331).

With regard to commenters' claims that economics was the basis for supporting or opposing the RDS height limit in I-14.1-2001 (as well as OSHA's proposed rule), OSHA notes that commenters on both sides of the issue claimed that the other side was seeking an economic advantage. Those commenters who supported the RDS height limit said employers were using RDS above 300 feet to win bids for window cleaning and save money (Ex. 215). For example, Mr. Gartner noted: "RDS is the least expensive method to service a building, saving the building owner money while allowing for the largest profit margin for a window cleaning contractor" (Ex. 331).

Commenters who opposed the 300-foot RDS height limit said large window cleaning companies that use powered platforms instead of RDS were pushing for the height restriction to gain an "unfair competitive advantage." Those commenters also said that prohibiting the use of RDS above 300 feet would result in loss of jobs, higher unemployment, and loss of income because it costs more to use powered platforms.

During the rulemaking hearing, OSHA asked Mr. Coleman, of JOBS, whose company only uses powered platforms, why the company did not support prohibiting the use of RDS since such a prohibition would be in his company's best economic interests. He replied: "Because . . . I understand the reality that it's here. It's going to be used and so I understand the importance of some regulation that's definite. Nothing that leaves a loophole, that leaves it up to the people in the field" (Ex. 329 (1/19/2011, pgs. 315-316)). Moreover, Mr. Coleman said the company did not lay off any employees or lose business

when they decided in 1985 to only use suspended scaffolding for suspended work (Ex. 329 (1/19/2011, p. 313)). Mr. Coleman testified that the company initially lost income because they did not change their prices even though using suspended scaffolding cost as much as 30 percent more than RDS use. He further noted that, the company eventually passed the cost to customers, "the building owners did not really flinch when they understood that we were not going to use a device that there was no OSHA regulation for. They saw their liability rise. So . . . window cleaning on a building, if you put it on a chart, probably won't even measure as a measurable cost for most buildings" (Ex. 329 (1/19/2011, p. 314)).

In conclusion, based on analysis of comments and the record as a whole, OSHA believes there is substantial evidence to support retaining the 300-foot height limit for RDS use.

Mr. Adkins, of Corporate Cleaning Services, recommended that OSHA, instead of prohibiting the use of RDS for heights greater than 300 feet, limit their use based on wind speeds³⁷ (Exs. 297; 360). Mr. Adkins' model assumes that a 25 mph wind speed and 300-foot rope length "yields a 'safe' horizontal displacement," which he calculated to be 5 feet (Ex. 297). According to his model, as the RDS rope length increases, the permissible wind speed decreases. Thus, for example, under Mr. Adkins' model when the rope length is 700 feet the permissible wind speed for RDS use would be 15 mph³⁸ (Ex. 297).

The rulemaking record, however, does not support Mr. Adkins' model or recommendation to replace the 300-foot RDS height limit with wind speed limits. First, according to a study, "Wind Effects on a Window Washer Suspended on a Rope," a 250-pound window cleaner hanging 75 feet down from a 300 foot building in a steady 25 mph wind would be displaced/deflected as much as 40 feet, which is far greater than the 5 feet Mr. Adkins' model predicts (Exs. 300; 352). Moreover, changes in wind speed (*i.e.*, gusts, stops) when window cleaners are deflected significantly more than 5 feet could cause them to swing back into the building resulting in death or serious injury. In fact, the study found that window cleaners can be knocked over by "moderate wind speeds" (*i.e.*, approximately 7 mph at 300 feet) and injured hitting buildings at a speed of 4

mph, both of which are significantly less than wind speeds Mr. Adkins says would be safe at 300 feet.

Second, many stakeholders did not support limiting RDS based on wind gusts instead of height (*e.g.*, Exs. 138; 147; 168; 206; 215; 300), or that the wind speeds limits Mr. Adkins recommends for RDS use above 300 feet would be safe (Exs. 153; 163; 184; 298; 317; 329 (1/19/2010, p. 411); 331; 352). Mr. Craig Schoch, of Tractel, Inc., said OSHA should reject Mr. Adkins' recommendation because his "safe" wind speeds are based on incorrect deflection assumptions (Ex. 352). Other stakeholders, including window cleaning contractors and members of the IWCA I-14.1-2001 committee, said wind speeds of 20-25 mph "are excessive" or "very dangerous," regardless of height (Exs. 317; 329 (1/19/2010, p. 411); 331). Several employers said they discontinue using RDS when wind speeds are between 15-20 mph and stop cleaning windows before winds reach 15 mph (Exs. 153; 163; 184; 298). Mr. Terry said 15 mph is a "reasonable" speed limit, but added that his company stops window cleaning before winds reach that speed (Ex. 163). And although Mr. Adkins recommended the wind speed alternative, he said:

Now, in actual fact, I've never had anybody work at 15 mph and never will because that, in my opinion, is too high for . . . a boatswain's chair, a swingstage, [and] a scaffold (Ex. 329 (1/19/2010, p. 213)).

Thus, OSHA does not believe there is sufficient evidence that Mr. Adkins' wind speed/rope length alternative would adequately protect of workers using RDS, and the final rule does not adopt that approach.

Final paragraph (b)(2)(i) includes two exceptions to the 300-foot height limit for using RDS. Employers may use RDS above 300 feet when they demonstrate (1) it is not feasible to access heights above 300 feet by any other means; or (2) other means pose a greater hazard than using RDS. The proposed rule would have allowed employers to use RDS at any height when the employer can demonstrate that "access cannot otherwise be attained safely and practicably," which is consistent with I-14.1-2001.

OSHA received a number of comments on the proposed exceptions. Some commenters opposed the proposed exceptions (Exs. 147; 215; 331). For example, Valcourt said:

In no case should a window cleaning contractor be allowed to determine when RDS is acceptable over 300 feet. . . . The determination that RDS can be utilized on a per case basis on descents over 300 feet

³⁷ Mr. Adkins said the term "wind speed" refers to wind gusts ("[W]hen I talk about wind speed, I talk about a gust" Ex. 329 (1/19/2010, p. 234)).

³⁸ Mr. Adkins said 9 mph would be a safe wind speed when the rope is 700 feet if the maximum speed allowed at 300 feet is 15 mph (Ex. 297).

should be made by a third party qualified person and/or, likely, a registered professional engineer experienced in facade access equipment (Ex. 147).

Mr. Coleman, of JOBS, agreed with Valcourt, stating, "This is a safety issue and should not be left up to an individual employer or employee to make an onsite decision of this nature" (Ex. 215).

Mr. Gartner, of Weatherguard, said OSHA's proposed exception allowing RDS use above 300 feet when employers cannot attain access "safely and practicably" was subjective and difficult to enforce (Ex. 329 (1/19/2011, pgs. 255–256)). He said, "What is practical for me may not be practical for you and what I deem to be safely is not necessarily what you consider safely" (Ex. 331).

OSHA agrees with the commenters and revised the language in the final rule to make it consistent with established legal tests and defenses under the OSH Act.

Final paragraph (b)(2)(ii) requires employers to ensure RDS use is:

- In accordance with manufacturer instructions, warnings, and design limitations (hereafter collectively referred to as "instructions"), or
- Under the direction of a qualified person.

The final rule (§ 1910.21(b)) defines qualified as someone who, by possession of a recognized degree, certificate, or professional standing, or who by extensive knowledge, training, and experience has successfully demonstrated the ability to solve or resolve problems relating to the subject matter, the work, or the project.

The I–14.1–2001 standard also requires that employers use RDS in accordance with manufacturer's instructions. In addition, the standard specifies that employers follow design requirements in I–14.1–2001 (Section 5.7.1).

OSHA believes that following manufacturer's instructions is critical to ensure the safety of workers who use RDS. To illustrate, manufacturers may design and sell ropes and equipment rated appropriately for recreational, but not industrial, use. The final rule requires that employers ensure they use only equipment that the manufacturer rated for industrial use. Similarly, under the final rule, employers must ensure that, if they replace elements of one manufacturer's RDS with the components of another manufacturer's system, the instructions specify that the components are compatible. Using incompatible systems or components could endanger the safety of workers and result in fatal accidents.

Proposed paragraph (b)(2)(i), like the 1991 RDS memorandum, would have required that employers use RDS in accordance with manufacturer or distributor instructions, and did not include the qualified person option. In the preamble to the proposed rule, OSHA requested comment about whether to allow employers to act in accordance with the instructions of either the manufacturer or a qualified person, as defined in § 1910.21(b) (75 FR 28886).

Commenters overwhelmingly supported adding the qualified person option and removing distributors (Exs. 138; 150; 153; 163; 184; 221; 220; 241; 242; 243; 245). For instance, Martin's said it was appropriate to allow employers to rely on qualified persons because they are "able to solve relevant problems" (Ex. 222). Mr. Gene Donaldson, of Sunlight Building Services (Sunlight), also preferred qualified persons because they "must have a recognized degree, certificate, etc., or extensive experience and ability to solve subject problems, at the worksite" (Ex. 227). Mr. Lawrence Green, president of Clean & Polish, said he supported replacing distributors with qualified persons "because distributors primarily sell the product to the end user and are not responsible for the safety, design and training of the personnel using them" (Ex. 242).

OSHA agrees with the commenters and revised final paragraph (b)(2)(ii) by adding qualified person and deleting distributor. The Agency believes the revised language in the final rule provides greater flexibility for employers, while ensuring that RDS use is at the direction of a person who is qualified.

Final paragraph (b)(2)(iii), like proposed paragraph (b)(2)(ii) and the 1991 RDS memorandum, requires employers to ensure that each worker who uses an RDS receives training in accordance with § 1910.30. This requirement means that the employer must train each worker who uses an RDS in the proper rigging, use, inspection, and storage of an RDS before the worker uses the RDS. In addition, since the final rule requires that each worker who uses an RDS also uses an independent personal fall arrest system (§ 1910.27(b)(2)(vi)), the employer must ensure that each worker receives fall hazard training before that worker uses an RDS in an area where the worker may be exposed to fall hazards (§ 1910.30(a)(1)). As final § 1910.30 specifies, the fall hazard training must include the nature and recognition of the fall hazards in the work area; the procedures to follow to minimize the

hazards; the correct procedures for installing, inspecting, maintaining, disassembling, and operating the fall protection systems workers will use, such as proper hook-up, anchoring, and tie-off techniques; and methods of inspection and storage of the equipment the manufacturer specifies (§ 1910.30(a)(1) and (3)). Moreover, to ensure that the RDS training meets the requirements of § 1910.30, employers also must provide retraining when they have reason to believe the workers do not have the understanding and skill needed to use RDS safely.

OSHA notes that the final provision is similar to the I–14.1–2001 standard, which requires that employers train workers who use RDS so they understand the manufacturer's instructions, inspection of components, accepted rigging practices, identifying anchorages, descending, fall arrest requirements, rescue considerations, and safe working conditions (Section 5.7.2).

OSHA believes that the final provision is necessary. Evidence in the record indicates that some employers do not train their workers who use RDS (Ex. 329 (1/19/2011, pgs. 86, 100)). OSHA believes, and commenters agreed, that workers are able to safely use RDS only if they are thoroughly knowledgeable in the equipment and its proper use (Exs. 66; 138; 151; 163; 153; 184; 216; 221; 222; 242; 243; 245; 329 (1/19/2011, pgs. 22–24, 433)). A number of commenters said proper training is the most important aspect of using RDS safely (Exs. 163; 184; 221; 242; 329 (1/19/2011, p. 252)). Those commenters also said that proper training would prevent most, if not all, of RDS incidents they identified (Exs. 163; 184; 221; 242). Similarly, Mr. Capon, of Valcourt, credited their training program as the reason their company did not have a fatality during its 25 years of operation (Ex. 329 (1/19/2011, pgs. 419–420)). Some commenters recommended that OSHA also require that employers use professional organizations to train and certify their workers (Exs. 123; 205). The performance-based approach in the final rule clearly allows employers to use professional organizations to provide training, and to require that workers receive certification to operate RDS. However, the performance-based approach of the final rule gives employers flexibility to determine how to train their workers, provided the training and the training contents meet the requirements of § 1910.30. Accordingly, OSHA does not believe it is necessary to adopt the commenters'

recommendation, and finalizes the provision as discussed.

Final paragraph (b)(2)(iv), like proposed paragraph (b)(2)(iii), requires that employers ensure inspection of each RDS at the start of each workshift in which their workers will use it. Additionally, the employer must ensure damaged or defective equipment is removed from service immediately and replaced. The equipment inspection must include every component of the RDS, including safety devices, ropes, rope grabs, lanyards, descent devices, harnesses, seat boards, carabiners and other hardware. When replacing damaged or defective equipment, the replacement component or system must be compatible, undamaged and not defective. Overwhelmingly, commenters supported the requirement to inspect RDS equipment (Exs. 138; 151; 153; 163; 184; 221; 222; 242; 243; 245).

The final rule revises the proposed paragraph to clarify the regulatory language. First, OSHA drafted the final provision to specify that employers must inspect each RDS “at the start of each workshift that it is to be used” rather than “each day before use” as in the proposed rule. Therefore, the final rule specifies that employers must inspect each RDS before a worker uses it in their workday. Thus, to the extent that there is more than one workshift in a work day, the RDS needs to be inspected to ensure it is safe for each worker to use during their workshift. The inspection of RDS equipment at the start of each workshift ensures that any damage (such as abrasions and cracks) that may have occurred when using the RDS during the last workshift is identified, and appropriate action is taken before another worker uses the RDS. In addition, employers need only inspect an RDS if a worker will use it during a workshift, rather than each day. The language in the final rule clarifies this requirement.

Second, the final rule requires that employers remove both damaged and “defective” equipment from service, while the proposed rule only specified removal of damaged equipment. OSHA added “defective” because, regardless of whether an inspection reveals that equipment was damaged during use or defectively manufactured, OSHA considers such equipment to be unsuitable for continued use.

Third, OSHA added language to the final rule specifying that employers remove damaged or defective equipment from service “immediately.” This addition is consistent with the I-14.1-2001 standard (Section 5.7.3).

Finally, the final rule revises the proposed rule to specify that employers

must replace damaged or defective equipment removed from service. OSHA believes this language clarifies that improvised repairs are not allowed, consistent with I-14.1-2001 (Section 5.7.3). Replacing damaged or defective components is necessary to ensure that RDS are restored to their original condition and capacity. For these reasons, OSHA adopts the final provision as discussed.

Final paragraph (b)(2)(v), like proposed paragraph (b)(2)(iv) and the 1991 RDS memorandum, requires that employers ensure the RDS has proper rigging, including proper anchorages and tiebacks. The final rule also requires that employers ensure that RDS rigging emphasizes providing tiebacks when using counterweights, cornice hooks, or similar non-permanent anchorage. The I-14.1 standard addresses proper rigging by requiring that employers train workers in “correct” and “accepted” rigging practices (Section 5.7.2).

Proper rigging of RDS equipment is essential to ensure that the system is safe for workers to use. To ensure proper RDS rigging and safe use, OSHA believes that employers also must take into consideration and emphasize the specific conditions present. For example, OSHA believes that giving particular emphasis to providing tiebacks when using counterweights, cornice hooks, or similar non-permanent anchorages is an essential aspect of proper rigging and necessary to ensure safe work. To illustrate, when tiebacks and anchorages are not perpendicular to the building face, it may be necessary for worker safety for employers to install opposing tiebacks to support and firmly secure the RDS, have at least a 30-degree sag angle for opposing tiebacks, or ensure that no angle exists on single tiebacks. In addition, as the final rule specifies, OSHA believes that employers also must place emphasis on non-permanent anchorages because of the possibility of damage during transport and installation.

Finally, some commenters recommended that OSHA include additional rigging requirements in the final rule. For example, Vannoy & Associates recommended that OSHA include a requirement for angle of attachment (Ex. 213). OSHA believes that the term “proper rigging” includes the angle of attachment and, therefore, needs no further elaboration. For the reasons discussed above, OSHA adopts the provision as discussed.

Final paragraph (b)(2)(vi), like proposed paragraph (b)(2)(v) and the 1991 RDS memorandum, requires that each worker uses a separate,

independent personal fall arrest system, when using an RDS. Final § 1910.140(b) defines personal fall arrest system as “a system used to arrest an employee in a fall from a walking-working surface.” A personal fall arrest system consists of at least an anchorage, connector, and a body harness, but also may include a lanyard, deceleration device, lifeline, or suitable combination of these devices (§ 1910.140(b)). The final rule requires that the personal fall arrest system meets the requirements in 29 CFR part 1910, subpart I, particularly final § 1910.140. This final rule is consistent with other existing OSHA standards (e.g., § 1910.66(j), Powered Platforms for Building Maintenance, Personal Fall Protection; § 1926.451(g), Scaffolds, Fall Protection), as well as the I-14.1 consensus standard (Section 5.7.6).

OSHA believes the provision is essential to protect workers from injury or death if a fall occurs. As the 1991 RDS memorandum mentions, requiring workers to use personal fall arrest systems that are completely independent of RDS ensures that any failure of the RDS (e.g., main friction device, seat board, support line, anchorage) does not affect the ability of the fall arrest system to quickly stop the worker from falling to a lower level.

Commenters uniformly supported the proposed provision (Exs. 138; 151; 153; 184; 221; 222; 242; 243). Also, Surface Solutions pointed out that 91 of 125 RDS incidents they reviewed as far back as 1977 resulted from the lack of an independent personal fall arrest system (Ex. 184). OSHA finds the comments and data persuasive and, therefore, adopts the requirement as proposed with only minor editorial change, for clarity.

Final paragraph (b)(2)(vii) requires that employers ensure all components of each RDS, except seat boards, are capable of supporting a minimum rated load of 5,000 pounds. For seat boards, the final rule requires that they be capable of sustaining a live load of 300 pounds. In accordance with section 6(b)(8) of the OSH Act (29 U.S.C. 655(b)(8)), OSHA revised the final provision in three ways to make it consistent with the I-14.1-2001 national consensus standard.

First, the final rule revised the proposal (proposed paragraph (b)(2)(vi)) to require that employers ensure “all components” of each RDS, except seat boards, are capable of supporting a 5,000-pound minimum rated load. As the final definition of RDS specifies, these systems usually consist of the following components: Roof anchorage, support rope, descent device, carabiner(s) or shackle(s), and chair

(seat board) (final § 1910.21(b)).³⁹ I–14.1–2001 (Section 14.1.2) also requires that each RDS must include the same list of components. The proposed rule (proposed paragraph (b)(2)(vi)) and 1991 RDS Memorandum, by contrast, only required that “all lines” be capable of sustaining the required load, but was silent on the minimum load requirements for other RDS components.

However, like I–14.1–2001, OSHA believes that requiring all RDS components, except seat boards, be capable of supporting the required minimum rated load is essential to ensure that these systems are safe for workers to use. It makes no difference if RDS lines and ropes are capable of supporting the minimum 5,000-pound required load if RDS connectors, anchorages, and other components cannot sustain such a load. In other words, all components must be able to support the required load because RDS are only as strong as their weakest component. Thus, applying the final load requirement to all RDS components will ensure that none of the critical components will break or fail when supporting a significant load. OSHA notes that commenters overwhelmingly support the minimum 5,000 load requirement as essential to ensure RDS are safe to use (Exs. 138; 151; 153; 184; 221; 222; 242; 243).

Second, in final paragraph (b)(2)(vii), consistent with I–14.1–2001 (Section 14.1.4), OSHA does not apply the 5,000-pound rated load requirement to seat boards. Instead, OSHA incorporates language from I–14.1–2001 (Section 14.3.1(c)) specifying that seat boards must be capable of supporting a live load of at least 300 pounds. I–14.1–2001 (Section 14.3.1(a)) specifies that seat boards must be made of “wood or other suitable material,” which cannot and does not need to support a rated load of 5,000 pounds. OSHA notes that final paragraph (b)(2)(vi), as mentioned, requires that employers ensure each employee who uses an RDS also uses a “separate, independent personal fall arrest system” that meets the requirements in final § 1910.140.

Third, the final rule, consistent with I–14.1–2001 (Section 14.1.4), revises the proposed rule to require that RDS components be capable of sustaining a minimum “rated load” of 5,000 pounds. The proposed rule specified that RDS lines be able to sustain a minimum “tensile load” of 5,000 pounds. OSHA believes that “rated load” or “rated strength” is the appropriate term to

specify the ability of all RDS components to support a load and is consistent with the I–14.1–2001 standard. I–14.1–2001 (Section 2) broadly defines “rated load” as “the combined weight of the [workers], tools, equipment, and other materials which the device is designed and installed to lift.” Tensile load, on the other hand, is the maximum stress that material can withstand while being stretched before breaking or failing. While the term is appropriate to use for identifying the required strength of ropes or lines, it is not a standard measure for components that do not stretch.

OSHA notes that the final rule does not preclude the use of lines or ropes that have a knot, swage, or eye splice, which could reduce the tensile strength of a rope or line. However, under final paragraph (b)(2)(vii), even if an employer uses a line or rope that has a knot, swage, or eye split, the rope or line still must be capable of supporting a minimum rated load of 5,000 pounds. Several commenters supported this interpretation of the final paragraph (b)(2)(vii).

In conclusion, OSHA believes that employers should not have difficulty complying with the final paragraph (b)(2)(vii) as revised. Virtually all RDS manufactured today meet the design requirements in I–14.1–2001 (Section 14) (See *e.g.*, Ex. 242). In addition, I–14.1–2001 represents standard industry practice, thus, OSHA believes that the revisions to final paragraph (b)(2)(vii) will make the final rule easier to understand and reduce potential for confusion.

Final paragraph (b)(2)(viii), like proposed paragraph (b)(2)(vii), requires that employers provide for prompt rescue of each worker in the event of a fall. The final rule is almost the same as the 1991 RDS memorandum and § 1910.140(c)(21), and generally consistent with the I–14.1 standard (Section 5.7.11).

Like § 1910.140(c)(21), final paragraph (b)(2)(viii) establishes two fundamental points—(1) employers must provide for the rescue of workers when a fall occurs, and (2) the rescue must be prompt. First, providing for rescue means employers need to develop and put in place a plan or procedures for effective rescue. The plan needs to include making rescue resources available (*i.e.*, rescue equipment, personnel) and ensuring that workers understand the plan.

Appendix C to § 1910.140 provides guidance to employers on developing a rescue plan (appendix C, Section (h)). For example, appendix C recommends that employers evaluate the availability

of rescue personnel, ladders, and other rescue equipment, such as mechanical devices with descent capability that allow for self-rescue and devices that allow suspended workers to maintain circulation in their legs while they are awaiting rescue. OSHA’s Safety and Health Information Bulletin on Suspension Trauma/Orthostatic Intolerance identifies factors that employers should consider in developing and implementing a rescue plan, including being aware of signs and symptoms of suspension trauma and factors that can increase the risk of such trauma, rescuing unconscious workers, monitoring suspended and rescued workers, and providing first aid for workers showing signs and symptoms of orthostatic intolerance (SHIB 03–24–2004).⁴⁰

Although an increasing number of employers train workers and provide devices that allow workers to rescue themselves (Exs. 227; 242), the employer’s rescue plan still needs to make provisions for appropriate rescue personnel and equipment because self-rescue may not be possible in some situations. For example, unconscious workers will not be able to move and, therefore, cannot pump their legs to maintain circulation or relieve pressure on the leg muscles. The same may be true for seriously injured workers or workers who are in shock. When RDS ropes get caught on structures or entangled, workers may not be able to self-rescue (see analysis of RDS and suspended scaffolding incidents in Ex. 163).

Second, the final rule requires that employers provide “prompt” rescue of workers suspended after a fall. Sunlight Building Services commented that “prompt” is ambiguous, and asked whether OSHA defines it to mean “immediately” or “quickly” (Ex. 227). The International Safety Equipment Association (ISEA) and Capital Safety Group (CSG) urged OSHA to require that rescue of suspended workers occur “quickly,” pointing out the life-threatening dangers of suspension trauma/orthostatic intolerance (Exs. 185; 198).

OSHA agrees with ISEA and CSG. OSHA’s definition of “quick” or “prompt” is performance-based. Prompt means that employers must act quickly enough to ensure that the rescue is effective; that is, to ensure that the worker is not seriously injured. If the worker is injured in the fall, the employer must act quickly enough to

³⁹ OSHA notes that RDS often include tiebacks, but they are not a required component of RDS.

⁴⁰ SHIB 03–24–2006 is available from OSHA’s Web site at: <http://www.osha.gov/dts/shib/shib032404.html>.

mitigate the severity of the injury and increase the survivability of the worker. OSHA's performance-based definition has consistently recognized, and taken into account, life-threatening injuries and dangers (Ex. 22; *see also* 76 FR 24576 (5/2/2011); Letter to Charles Brogan, January 16, 2007; Letter to Brian F. Bisland (March 23, 2007)). For example, OSHA's Safety and Health Information Bulletin (SHIB) on orthostatic intolerance explains:

Orthostatic intolerance may be experienced by workers using fall arrest systems. Following a fall, a worker may remain suspended in a harness. The sustained immobility may lead to a state of unconsciousness. Depending on the length of time the suspended worker is unconscious/immobile and the level of venous pooling, the resulting orthostatic intolerance may lead to death. . . . Unless the worker is rescued promptly using established safe procedures, venous pooling and orthostatic intolerance could result in serious or fatal injury, as the brain, kidneys, and other organs are deprived of oxygen.

Prolonged suspension from fall arrest systems can cause orthostatic intolerance, which, in turn, can result in serious physical injury, or potentially, death. Research indicates that suspension in a fall arrest device can result in unconsciousness, followed by death, in less than 30 minutes (SHIB 03-24-2004).

In sum, prompt rescue means employers must be able to rescue suspended workers quickly enough to ensure the rescue is successful, *i.e.*, quickly enough to ensure that the employee does not suffer physical injury (such as injury or unconsciousness from orthostatic intolerance) or death. Many employers provide self-rescue equipment so workers can rescue themselves quickly after a fall, ensuring that the rescue is prompt and risks associated with prolonged suspension are minimal. OSHA believes the performance-based approach in the final rule will ensure prompt rescue of workers after a fall, while also giving employers flexibility to determine how best to provide prompt and effective rescue in the particular circumstance.

Commenters uniformly supported the proposed provision (Exs. 138; 153; 184; 221; 222; 242; 243). Clean & Polish said, "It is a documented fact that there is a great risk of suspension trauma when hanging from a harness." Accordingly, they recommended that a team of at least two workers should perform every job assignment and that workers receive training in self-rescue (Ex. 242). Sunlight also supported self-rescue, saying it is the quickest form of rescue, followed by assistance from a coworker trained in rescue. Sunlight added that,

in a medical emergency, they recommend calling the local fire department (Ex. 227). A number of commenters said they train their own workers in rescue and require them to practice/demonstrate their rescue capabilities at least twice a year (Exs. 184; 221; 227; 243).

The final rule is performance-based and gives employers flexibility to select the rescue methods that work best for their workers and worksite. However, OSHA emphasizes that, whatever rescue methods employers use, they are responsible for ensuring that it provides prompt rescue. Some commenters said they rely on calling local emergency responders, which may or may not be adequate. If employers rely on this method of rescue, they need to ensure that the responders have the appropriate equipment to perform a high angle rescue and are trained and qualified to do so. (Also see the discussion of prompt rescue in final § 1910.140 below.)

Final paragraph (b)(2)(ix), consistent with proposed paragraph (b)(2)(viii), the 1991 RDS memorandum, and I-14.1 (Section 5.7.5), requires that employers ensure the ropes of each RDS are effectively padded or otherwise protected where they contact edges of the building, anchorage, obstructions, or other surfaces to prevent them from being cut or weakened. Padding protects RDS ropes from abrasion that can weaken the strength of the rope. If employers do not protect RDS ropes, the ropes can wear against the sharp edges of buildings (*e.g.*, parapets, window frames, cornices, overhangs), damaging their structural integrity and possibly causing them to break.

The final rule requires that employers ensure the rope padding is "effective." To be effective, padding needs to be, for example, firmly secured in place and strong and thick enough to prevent abrasion. To ensure the padding remains effective, employers also need to inspect it "regularly and as necessary" (final § 1910.22(d)(1)).

OSHA added language to the final rule specifying that employers may ensure that ropes are padded or "otherwise protected." OSHA believes the added language gives employers greater flexibility in complying with final (b)(2)(ix). OSHA recognizes that padding may not be the only effective measure available to employers. For example, several commenters said that parapet carpets and rope-wrapper protection are effective rope protection devices (Exs. 138; 153; 184; 221; 242). Other available measures include rubber hoses and polyvinyl chloride (PVC) piping. OSHA believes that various

materials are readily available and used in common industry practice; thus, employers should not have significant problems complying with the final rule.

Overwhelmingly, commenters supported the provision (Exs. 138; 153; 184; 221; 222; 242; 243), and OSHA did not receive any comments opposing the requirement. Therefore, OSHA adopts the provision as discussed.

Final paragraph (b)(2)(x), like proposed paragraph (b)(2)(ix), requires that employers provide stabilization at the worker's specific work location whenever descents are greater than 130 feet. The purpose of the stabilization requirement is to reduce the risks of worker injury when longer descents are made using a RDS.

For purposes of final paragraph (b)(2)(x), the worker's "specific work location" refers to the location in the descent where the worker is performing the work tasks that necessitate the use of an RDS. For example, a window cleaner's specific work location is the window the worker is cleaning. While using an RDS, workers may have many specific work locations during a descent, and they must be stabilized at each of those locations when the descent is greater than 130 feet.

OSHA uses a performance-based approach in final paragraph (b)(2)(x). It gives employers the flexibility to use intermittent or continuous stabilization. In addition, the final rule allows employers to use any method of stabilization (*e.g.*, suction cups, rail and track system) that is effective to protect workers from adverse environmental effects, such as gusty or excessive wind.

OSHA notes that the 1991 RDS memorandum included a requirement for "intermittent" stabilization on descents in excess of 130 feet.⁴¹ Similarly, the I-14.1 standard, which also requires stabilization on descents greater than 130 feet, specifies that stabilization may include continuous, intermittent, or work station stabilization (Section 5.7.12). The I-14.1-2001 standard identifies suction cups as an example of work station stabilization.

In the proposed rule, OSHA requested information on commonly used methods of stabilization and on other methods that may increase worker safety. The vast majority of commenters

⁴¹ Shortly after OSHA issued the 1991 RDS memorandum, the Agency confirmed that employers could use suction cups to meet the stabilization requirement in the memorandum (Letter to Mr. Michael Bell, July 31, 1991, available on OSHA's website at: http://www.osha.gov/portable_ladders/oshaweb/owadisp.show_document?p_table=INTERPRETATIONS&p_id=22722).

said suction cups are the method they most use for stabilization (Exs. 138; 163; 184; 221; 222; 241; 242). Some commenters said they use different methods for stabilization, but only mentioned suction cups, and said suction cups is their “primary” method (Exs. 163; 184; 221; 242; 329 (1/19/2011, p. 436)).

Sunlight said that some buildings have permanent rail or track systems to provide stabilization (Ex. 227). TRACTEL North America (TRACTEL) also said they use “mulling and track,” designed for use by powered platforms for stabilization, to stabilize RDS (Ex. 329 (1/19/2011, p. 436)). TRACTEL added that mulling and track stabilization systems provide greater protection because the stabilization is continuous, while suction cups only provide intermittent protection (Ex. 329 (1/19/2011, p. 436)).

Many commenters supported the RDS stabilization requirement for work operations involving descents greater than 130 feet (Exs. 138; 147; 151; 215; 222; 241; 227; 356), and a number of commenters supported the use of suction cups as an effective stabilization method (Exs. 138; 151; 152; 222; 241).

However, a number of commenters said stabilization is not necessary. They indicated there was no need for a stabilization requirement because the prohibition against using RDS in adverse or hazardous weather is adequate and a more protective approach (Exs. 163; 184; 221; 227; 241; 242; 243). Mr. Terry, of Sparkling Clean, explained:

Every incident that can be partially abated by stabilization can be totally abated by substituting a restriction from working in adverse weather restrictions. Suspended workers using [RDS] only need stabilization during adverse weather conditions. . . .

[Suction cups] can certainly be used for stabilization, if a worker chooses to work in adverse conditions that should have been avoided in the first place. . . . (Ex. 163).

Ms. McCurley, of SPRAT, also said the proposed requirement was not necessary:

Sometimes stabilization is required, and when stabilization is required, the stabilization needs to be adequate to the situation. But, stabilization is not necessarily required just as a matter of course. . . . [T]hat requirement tends to come from the scaffold industry, which does require stabilization all the time, because that's what scaffolds do. They have to have stabilization. But, because of the individual not having nearly the wind load—a wind load on this table, because it looks a lot like an airplane wing, is going to have a much different effect than the same wind load on your body standing there (Ex. 329 (1/19/2011, pgs. 167–168)).

Nevertheless, Mr. Terry and other commenters said they provide stabilization devices (primarily suction cups) and use them on descents as short as 10 feet (Exs. 163; 184; 221; 242; 329 (1/19/2011, p. 62)). Mr. Terry pointed out that his company uses the suction cups “for positioning to keep us in front of the glass, not for stabilization against the effects of the wind” (Ex. 329 (1/19/2011, p. 337)).

Mr. Diebolt, of Vertical Access, did not oppose the concept of stabilization, but opposed OSHA’s 130-foot trigger:

Now, the 130-foot tie-offs, I have essentially the same objections. It seems arbitrary for the kind of work at least that we do, it's unnecessary. . . . Granted we're doing light work, making observations and notes and that sort of thing. Occasionally, we have done some work like take core samples out of a concrete structure using a coring rig drill rig hung from a separate line. And under those conditions, you do actually have to put in a bolt or something to hold you to the building. . . . when you're on a long pendulum, when you're on a long tether.

But making it mandatory seems arbitrary and sort of eliminates the possibility of the flexibility of doing the work (Ex. 329 (1/21/2011, pgs. 139–140)).

However, the major objection to the proposed rule was not to the proposed regulatory text, but rather with the use of suction cups as a stabilization method. The Glass Association of North America (GANA), a trade association representing the architectural and glazing industry, recommended that OSHA not to allow the use of suction cups for worker stabilization:

Glass is a brittle material and, as such, can break without warning and vacate the window framing system. Glass installed in commercial and residential buildings is designed to withstand external loads, primarily wind events, with a certain safety factor. . . . In other words, breakage cannot be eliminated in brittle materials like glass. There is no way to guarantee a specific lite of glass will not break under the loads exerted by workers as they move vertically and horizontally back and forth across the glass lites. . . . The use of suction cups may be sufficient in certain conditions to cause the glass to break and vacate the opening, particularly in the event the RDS fails and the worker is left to rely upon the suction cups used for stabilization. . . . to support his/her weight.

GANA urges OSHA, in its final rule, to reject the use of suction cups as an approved employee work location stabilization device for RDS. . . . Their use does not satisfy the safety criteria OSHA has established for this rulemaking proceeding: “to be effective, fall protection systems must be both strong enough to provide the necessary fall protection and capable of absorbing fall impact so that the forces imposed on employees when stopping falls do not result in injury or death” (Ex. 252).

Mr. Gartner, of Weatherguard, and Mr. Coleman, of JOBS, opposed the use of suction cups for the same reasons as GANA (Ex. 215; 329 (1/19/2011, pgs. 259–260)). Mr. Gartner said:

The use of suction devices for stabilization is problematic. The glass industry strongly discourages them and the window wall people are robustly against them. They are devices used at whim. The loads that they apply to a surface are totally unknown as there are numerous barrier bowls that influence them and they're applied to surfaces that have never been rated for these pinpoint concentrated loads.

Applying a device to glass seems reckless when we're all aware of glass's characteristics and lack of strength. Furthermore, as glass ages, it becomes more brittle and it loses strength, just another variable to make their use totally uncontrolled (Ex. 329 (1/19/2011, pgs. 259–260)).

Mr. Coleman also stated:

In order for Work Station Stabilization to be safe, the worker must attach to a component of the building curtain wall that is designed for and capable of providing the stabilization required. Presently most Work Station Stabilization is done by using suction cups attached to the glass pane. The glass is typically not designed for such point loading; it is designed for a wind load spread out over the entire surface of the glass (Ex. 215).

Therefore, Mr. Coleman concluded that the final rule should not allow suction cups, which provide only intermittent stabilization, as the primary stabilization device (Ex. 356). Rather, he said OSHA should define “Work Station Stabilization” as: “a means to stabilize suspended access equipment by securing the worker or suspended access equipment to an approved anchor point on the exterior of the building surface,” thus ensuring continuous stabilization (Ex. 215). Mr. Schoch, of TRACTEL, agreed with Mr. Coleman’s recommendation (Ex. 329 (1/19/2011, p. 439)).

Several workers, based on personal experience, also opposed the use of suction cups, calling the devices “unsafe” (Exs. 311; 316; 329 (1/19/2011, pgs. 5, 8, 15, 18, 19, 61, 62); 329 (1/20/2011, p. 222)). For instance, Mr. Rosario, of SEIU Local 32BJ, stated:

I believe the use of suction cups fails to provide adequate protection. Suction cups are unreliable because they get dirty and fail to maintain suction. I remember having to clean 20-story buildings, sometimes with multiple stops per floor. At least half the time I applied the [suction] cup, it released during the cleaning and I had to apply it again (Ex. 311).

Mr. Rosario also said the support offered by suction cups “usually only lasts for a few seconds” (Ex. 329 (1/19/2011, p. 19)). Mr. Rosario added that

usually he had to clean suction cups four or five times per descent (Ex. 329 (1/19/2011, p. 86)). Mr. McEneaney, with SEIU Local 32BJ, said suction cups were not reliable stabilization devices because they leave the worker “destabilized during the movement from one floor to another” (Ex. 329 (1/19/2011, p. 15)). However, most commenters said they primarily use suction cups for stabilization, and did not indicate they were not effective (Exs. 138; 163; 184; 222; 227; 241; 242).

After reviewing the rulemaking record, OSHA decided, for several reasons, to adopt the stabilization requirement as proposed. First, OSHA believes, and many commenters agreed, that stabilization of RDS is necessary to protect workers on descents greater than 130 feet. The effects of wind gusts, microbursts, and tunneling wind currents on longer RDS ropes is particularly severe and likely to increase the risk of injury to workers. For instance, increases or changes in the wind can cause a significant pendulum effect on the long RDS ropes, and will cause workers not stabilized to swing a great distance away from or into the building, possibly causing injury or death. For example, the RDS accident data analysis Mr. Terry submitted indicated that strong wind gusts (more than 35 mph) swung two workers using RDS 30 feet away from a building (Ex. 163).

In addition, even a single wind gust or a sudden drop in the wind speed can initiate this pendulum effect on RDS ropes and destabilize the workers using them. Moreover, when RDS ropes are long, the slightest wind movement also can cause the ropes to sway (*i.e.*, pendulum effect) and swing or propel workers into the building. OSHA believes that requiring stabilization in these situations will prevent RDS ropes from swaying and buffeting workers against the building.

Mr. Terry’s accident analysis demonstrates what can happen when workers are not using stabilization, and how using stabilization could prevent such cases. Three RDS accidents in that analysis involved wind:

- Window cleaner cleaning 50-story building became stranded in descent equipment line as a result of a wind gust;
- Window cleaner was stuck between 12th and 13th floor and managed to rest on narrow window ledge. Winds that were gusting 35 mph caught his ropes and wrapped them around an antenna on the west side of the building so worker was unable free to himself; and
- Two window cleaners were left dangling from a building when their

lines became tangled during a windy rain shower. Wind was gusting about 36 mph. The workers were stuck between the 11th and 14th floors and blown 30 feet away from the building (Ex. 163).

OSHA believes that stabilization, as required by this final standard, could prevent many such incidents.

Second, while OSHA agrees that employers must not allow workers to perform suspended work in hazardous weather and gusty or excessive winds, the Agency also recognizes that adverse conditions can suddenly occur without warning. When such conditions occur, employers must ensure that workers using RDS have stabilization methods immediately available so they can protect themselves from the effects of the wind, even if all they are doing is descending to stop work due to hazardous weather conditions. OSHA notes that even those commenters who asserted that stabilization is not necessary because weather restrictions can totally abate the hazard, also noted that they regularly use and rely on stabilization devices, even on descents as short as 10 feet (Exs. 163; 184; 221; 242).

Third, the final rule is consistent with the I-14.1-2001 national consensus standard. The I-14.1-2001 standard also requires that employers ensure workers using RDS have stabilization at their work station on all descents greater than 130 feet (Section 5.7.12). The I-14.1-2001 standard reflects best industry practices.

With regard to suction cups, for the following reasons OSHA decided not to prohibit their use under the final rule. First, OSHA believes that suction cups provide effective stabilization for workers using RDS, particularly in long descents. The record shows that suction cups are an effective and easy-to-use device that helps keep workers positioned or stabilized at their specific work location (Exs. 137; 138; 147; 153; 163; 184; 298).

OSHA received a comment from GANA stating that suction cups are not safe or effective to use for stabilization (Ex. 252). GANA’s comment appears to indicate that they believe suction cups are a type of personal fall protection system, and concludes suction cups are not effective because the cups are not “strong enough to provide the necessary fall protection and capable of absorbing fall impact so that the forces imposed on employees when stopping falls do not result in injury or death” (Ex. 252). GANA also says suction cups are not effective because they cannot support the worker’s weight if the RDS and personal fall arrest system both fail (Ex. 252). However, OSHA agrees with

IWCA’s post-hearing comments that GANA’s description of the purpose and use of suction cups is not accurate (Ex. 346). As IWCA points out, and OSHA agrees, “Suction cups are not intended to be part of the fall protection system and they are not part of the fall protection system” (Ex. 346).

The second reason for allowing suction cups is that OSHA believes suction cups can provide stabilization and protection when sudden weather conditions occur while the worker is using an RDS, even if workers use the suction cups only to safely descend due to excessive wind. As Mr. Terry said, “In the event of a sudden unforeseen weather hazard, the [RDS user] . . . can very easily . . . utilize the suction cup. . . . This method of stability can even be performed while descending out of harm’s way” (Ex. 329 (1/19/2011, p. 329)).

Third, OSHA believes that suction cups are widely used and accepted by employers and workers who use RDS, even by those employers who doubt the need for stabilization, because the devices have a track record of being effective, and economical. As far back as July 31, 1991, OSHA allowed employers to use suction cups to meet the stabilization requirement in the 1991 RDS memorandum. IWCA said that, since 1991, the use of suction cups in conjunction with RDS is widespread among window cleaning companies and workers in the United States and other countries (Ex. 346). Over that period, neither OSHA nor IWCA are aware of any data or evidence indicating that a significant problem exists with using suction cups. Although GANA said it is not safe to use suction cups on glass, they did not provide any data indicating that suction cups are causing glass windows to break (Ex. 252). Moreover, according to IWCA, a 2010 GANA press release said their members did not have any record of windows breaking when window cleaners were using suction cups (Ex. 346). OSHA notes that a review of the rulemaking record failed to show that suction cups cause anything more than a few isolated cases of window breakage. For example, Mr. John Capon, of Valcourt, reported that each year his company only had to replace 15 to 20 windows on the approximately 4,000 buildings they clean 2–3 times each year because of suction cup-related damage (Ex. 329 (1/19/2011, p. 372, 399)).

Finally, the performance-based final rule allows, but does not require, the use of suction cups for stabilization. Employers are free to use other devices, and some commenters said they use other stabilization methods, such as rail

and track systems, that provide continuous stabilization (Exs. 163; 184; 221; 242; 329 (1/19/2011, p. 436)).

Based on the above discussion, OSHA concludes that stabilization is essential at specific workplaces where descents are greater than 130 feet and is finalizing the provision as proposed.

Final paragraph (b)(2)(xi) is a new provision added to the final rule that requires employers to ensure no worker uses an RDS when “hazardous weather conditions” are present. The final provision also identifies some examples of weather conditions that OSHA considers hazardous for workers using RDS: Storms and gusty or excessive wind.

OSHA’s general industry standard on powered platforms (§ 1910.66) and construction standard on scaffolds (§ 1926.451) also prohibit elevated work when certain weather conditions are present. Specifically, the powered platforms standard prohibits using powered platforms in winds in excess of 25 mph, and requires that employers determine wind speed based on “the best available information, which includes on-site anemometer readings and local weather forecasts, which predict wind velocities for the area” (§ 1910.66(i)(2)(v)). The construction standard prohibits work on scaffolds during storms or high winds “unless a competent person has determined that it is safe for employees to be on the scaffold and those employees are protected by personal fall arrest systems or wind screens” (§ 1926.451(f)(12)).

The I–14.1 standard also prohibits window cleaning operations and RDS use when the “work area is exposed to excessive winds,” which the standard defines as “any wind which constitutes a hazard to the worker, public or property” (Sections 3.7 and 5.7.12). The I–14.1 also requires that employers train workers in the effects of wind on RDS operations, and make workers aware of “the potential of sudden climatic changes such as wind gusts, micro bursts or tunneling wind currents” when they perform descents over 130 feet (Section 5.7.11(a)).

In the preamble to the proposed rule, OSHA requested comment on a number of issues regarding hazardous weather conditions including the following (75 FR 28886):

- Should the final rule prohibit RDS use in certain weather conditions? If so, what conditions?
- How should employers determine whether weather conditions are hazardous?
- How should OSHA define excessive wind?

- Should the final rule prohibit RDS use if winds reach a specific speed? If so, what speed?

- Should the final rule require that employers monitor winds speeds? If so, how?

Overwhelmingly, commenters supported prohibiting the use of RDS, as well as suspended scaffolding, in inclement or hazardous weather (Exs. 151; 163; 184; 221; 222; 227; 241; 242; 243; 329 (1/19/2011, p. 329)). They also agreed that conditions such as “thunderstorms, lightning; hail, high winds, hurricane, snow and ice storms” were hazardous. Sunlight added that heavy rain and extreme cold also make RDS use hazardous: “Rain can affect the operation of the working line but the use of rope that is essentially waterproof can negate this problem. Very cold weather stiffens the rope and especially wet rope can be a hazard” (Ex. 227).

In addition, some commenters said that as the length of rope during a drop increases, the effects of wind on RDS can increase (Exs. 147; 329 (1/19/2011, pgs. 253, 291–292)). As mentioned in the proposed rule, the greater the length of rope used for a descent, the greater the adverse effects of environmental factors such as wind gusts, microbursts, or tunneling wind currents, and the greater the risk of injury to workers (75 FR 28886). OSHA notes that some window cleaning companies disagreed that greater heights pose greater wind effects on RDS (Exs. 222; 247; 329 (1/19/2011, p. 329)). Dana Taylor, of Martin’s, said their accident analysis files did not show any RDS accidents occurring due to excessive wind (*i.e.*, “wind gusts, microbursts or tunneling wind currents”) (Ex. 222). Sam Terry of Sparkling Clean said:

The adverse effects of environmental factors do not affect rope access any more than they affect suspended scaffolding. In actuality, users of rope access have the ability to get themselves and their equipment out of harm’s way should unexpected weather hazards suddenly appear much quicker than users of suspended scaffolding.

In the event of a sudden unforeseen weather hazard, the user of rope access can very easily use their hands, arms, legs, and feet to hold on to parts of the building or structure or to utilize the suction cup as long as a smooth surface is available. This method of stability can even be performed while descending out of harm’s way. (Ex. 329, 1/19/2011, p. 329)).

Commenters also had different viewpoints about defining “excessive” wind. Some commenters said winds were excessive and dangerous when they reached 25 mph (Exs. 227; 329 (1/19/2011, p. 411)), while others said winds in excess of 15 mph were too high to use RDS (Exs. 138; 151; 152;

222; 329 (1/19/2011, p. 329)). For instance, John Capon of Valcourt said: “I don’t work . . . in more than 10 or 15 miles per hour [wind] and I almost look at that as normal. That seems a little awkward to me because that’s not very windy at all. When it gets to 20 and 25 miles per hour, to me it gets very dangerous” (Ex. 329 (1/19/2011, p. 411)).

Several stakeholders in the window cleaning industry indicated that including a 15-mph or 25-mph wind speed limit in the final rule was not necessary. Texas Window Cleaning Company said: “Not many window cleaners are going to risk their health on wind, storm or other increments of bad weather. They know and are trained when, where and how to postpone the cleaning” (Ex. 218).

Other window cleaning companies indicated that water “blowback” stops window cleaning operations long before winds reach 15 mph to 25 mph (Exs. 151; 163; 329 (1/19/2011, pgs. 213–214)). Mr. Adkins, of Corporate Cleaning, explained:

I’ve never had anybody work at 15 miles an hour and never will because that, in my opinion, is too high, both for a boatswain’s chair, a swingstage, a scaffold. Also, I might add there’s something else that happens with window washing and that’s the blowback effect. Window washers don’t like to do their work over, and at a certain level of wind, you wind up with dirty water blowing on clean windows . . . which, of course, the customer doesn’t like. They want us to come back, do it over. So, consequently, that’s a lower level normally than anything where you have to worry about safety. Most normal window washers will shut down and we support this, we fully support this because I don’t want the phone call from the property manager. Most window washers will shut down before they reach an unsafe level, before they come anywhere near it. The most I think I’ve ever seen our company working is in 15-mph winds (Ex. 329 (1/19/2011, pgs. 213–214)).

For companies that use RDS to perform operations that do not have the “built-in monitoring” capability for blowback of water, several commenters said, “[I]t would seem to me that a 15 mph limit is reasonable” (Exs. 163; 221).

The American Wind Energy Association (AWEA), however, opposed adding any wind-speed restriction to the final rule because it would be “detrimental” to the wind energy industry, which works in windy areas (Ex. 178). AWEA said that OSHA should allow employers to establish their own “detailed policies and [job hazard analyses] for work in inclement weather” (Ex. 178). Mr. Diebolt, of Vertical Access, also agreed that employers should be able to set their own weather policies:

Just a word about weather and changing site conditions. Wind has been a concern and understandably. But you can understand after AWEA's testimony this morning that a wind effect of somebody hanging on the outside of a turbine or working on top of a nacelle is entirely different from somebody working on a bridge, pier, abutment or the side of a building (Ex. 329 (1/21/2011, pgs. 139–140)).

With regard to monitoring wind speed, several window cleaning companies indicated that it was not necessary because “blowback” of water is an adequate measure (Exs. 138; 163; 222). That said, some of these companies recommended that employers monitor weather reports in their area and notify workers of changes that would prohibit the use of RDS (Exs. 151; 163; 222). Sunlight noted that “the use of [B]lackberry, PDAs, internet and cell phones give the employer the tools to monitor weather conditions in real time” (Ex. 227).

OSHA agrees with commenters who said the final standard must prohibit the use of RDS when weather conditions are hazardous for workers and the equipment. As the record and OSHA standards indicate, workers using RDS are vulnerable to sudden weather changes such as wind gusts, microbursts, and wind tunneling. Gusts and excessive winds can cause workers using RDS to swing into buildings, resulting in possible injury or death.

OSHA believes that employers' support of a mandatory prohibition on RDS during windy weather indicates that they are aware of the hazards posed by inclement weather. That said, the record indicates that what constitutes “hazardous” weather and “excessive” wind is dependent on the type of work performed when using RDS. For window cleaning, the record shows that water blowback acts as a reliable sign that winds have become excessive, even if they are well below 15 mph. However, for other jobs it may be safe to use RDS at higher wind speeds, depending on the type of job performed. For instance, the record indicates that using an RDS below 130 feet may be safe when winds approach 25 mph, but hazardous when using RDS at heights approaching 300 feet, or when the length of the descent rope is long.

In light of the many variables of RDS use, OSHA decided that using a performance-based approach in the final rule is the most effective way to cover varying worksite and job conditions. Under the performance-based final rule, employers must evaluate or analyze the worksite and job variables in light of existing weather conditions. If that analysis indicates that weather

conditions are hazardous and winds are excessive, the employer must ensure that no employee uses an RDS. OSHA believes this approach will best ensure that employers provide an adequate level of safety, and take appropriate measures to protect workers in each specific work operation. Moreover, OSHA believes the performance-based final rule will not impose significant burdens on employers. The record shows that employers said they already monitor on-site weather conditions to determine whether to proceed with or postpone the job.

OSHA also believes the performance-based approach obviates the need to require in the final rule that employers conduct on-site weather monitoring or use specific weather-monitoring systems. The record shows that many employers currently use various electronic tools to monitor local weather forecasts.

Final paragraph (b)(2)(xii), like proposed paragraph (b)(2)(x), requires that employers ensure equipment is secured by a tool lanyard or similar method to prevent it from falling. Examples of equipment include tools, squeegees, and buckets. The purpose of this provision is to protect workers and the public below from being struck by falling equipment. The final rule is consistent with the I–14.1–2001 standard (Sections 3.10 and 5.7.15), and supplements the falling object requirements in final § 1910.28(c) (Protection from falling objects).

Several commenters, including IWCA, supported the requirement (Exs. 138; 151; 153). However, Mr. Donaldson, of Sunlight, said the provision was not practical or needed (Ex. 227). In particular, he stated that tool bungees are imperative to the window cleaning business, but a serious impediment to the use of squeegees or other tools. Therefore, he suggested the following alternative to the final rule:

The danger of workers below being struck by falling equipment is minimal. Workers rarely work directly below other workers. The tools themselves are light and blunt and could not cause serious injury unless dropped from a great height. . . . Requiring window cleaners to wear hard hats would be a more practical solution than tool bungees (Ex. 227).

AWEA also suggested additional alternatives:

[T]here are various ways to protect workers from falling objects in the wind industry. Workers are prohibited to work below other workers when using items that can fall. In addition, workers often use tool tethers for equipment. Typically, tools are hoisted in tool buckets versus being carried by workers. This practice allows the trained employee

free use of his hands and mitigates the potential for tools falling out of workers' pockets (Ex. 329 (1/21/2011, p. 12)).

OSHA does not agree with Sunlight's comment for several reasons. First, OSHA believes the performance-based approach in the final rule assures that employers have maximum flexibility in meeting the requirement to secure equipment (*e.g.*, tools, squeegees, buckets) that workers use. Many different types of tool lanyards and similar methods are currently available to secure equipment. Tool lanyards and other securing equipment are available in many types, lengths, and load capacities, and a worker can secure the equipment at various points, including the worker's wrist, tool belt, harness, and seat board.

Second, Mr. Donaldson did not provide any explanation about how or why tool bungees are a “serious impediment” to using squeegees and other tools. OSHA did not receive any other comments supporting Mr. Donaldson's claim.

Third, OSHA disagrees with Mr. Donaldson's assertion that falling tools will not cause serious injury if they hit workers below. Many of the tools employees use in suspended work can be heavy and sharp (*e.g.*, a bucket of cleaning water or the corner at the end of a squeegee). Tools can cause injury to various parts of the body, especially if dropped from significant heights. In any event, Mr. Donaldson's recommendation that employees wear head protection when they work below elevated workers, such as window cleaners, will not protect other persons who also may be below.

With regard to the controls AWEA identified, OSHA believes that tethering controls is one way employers can comply with the final rule. As to the other controls AWEA suggested, OSHA believes that securing equipment is the most protective option because it removes the hazard of equipment falling and hurting workers. Putting tools in buckets and prohibiting employees from working below other workers, as AWEA suggests, does not prevent equipment from dropping and, in the case of prohibiting work below the worker, requires ongoing monitoring by the employer to be effective. Thus, OSHA believes that the final rule establishes the most protective control, and likely the most efficient one. Accordingly, OSHA adopts the requirement that employers ensure that equipment used in RDS work is secure to prevent it from falling and injuring workers and the public.

Final paragraph (b)(2)(xiii), like proposed paragraph (b)(2)(xi), requires

that employers protect RDS ropes from exposure to open flames, hot work, corrosive chemicals, and other destructive conditions that could damage or weaken the ropes. This requirement will prevent damage to ropes that could lead to failure. Failure of a suspension or fall arrest line could seriously injure or kill a worker.

The performance-based approach in final paragraph (b)(2)(xiii) gives employers flexibility in determining how to protect RDS ropes from damage. OSHA believes that this approach is appropriate for the final rule because there are various controls available to protect RDS ropes from damage. This approach also is consistent with the I-14.1-2001 standard, which prohibits the use of hazardous or corrosive materials that could “endanger the . . . safety of the worker or may affect the safe operation of equipment” (Section 3.5).

A number of commenters supported the provision (Exs. 138; 151; 153; 184; 221; 222; 243), and OSHA did not receive any comments opposing the provision, and finalizes the provision as proposed.

Section 1910.28—Duty To Have Fall Protection and Falling Object Protection

Final § 1910.28 is the first of three new sections in subpart D that consolidate requirements pertinent to fall protection and falling object protection. The new sections are:

- § 1910.28—Duty to have fall protection and falling object protection;
- § 1910.29—Fall protection systems and falling object protection—criteria and practices; and
- § 1910.30—Training.

Final § 1910.28 specifies the areas and operations where employers must ensure that workers have fall and falling object protection and what type(s) of protection employers may use. The criteria for fall and falling object protection that employers use to comply the duties imposed by § 1910.28, and the training workers who use those systems must receive are in §§ 1910.29 and 1910.30, respectively. OSHA notes that § 1910.140 specifies criteria for personal fall protection systems that employers must meet when their workers use these systems.

OSHA believes these sections along with the general requirements in § 1910.22, taken together, establish a comprehensive approach to fall and falling object protection. OSHA believes this approach will ensure a better understanding of the final rule, fall hazards, and fall protection systems; provide flexibility for employers when choosing a fall protection system and

falling object protection; ensure the systems they choose will be effective; and most importantly, will reduce significantly the number of fall injuries and fatalities in general industry.

Final § 1910.28, like the proposed rule, consolidates most of the general industry fall and falling object protection requirements throughout subpart D. OSHA patterned this section after the construction fall protection standard (29 CFR 1926.501, Duty to have fall protection). OSHA draws the range of fall protection options in the final rule, for the most part, from the construction standard. These options include engineering controls (e.g., guardrails, safety net systems), personal fall protection systems (e.g., personal fall arrest systems, travel restraint systems, positioning systems), and administrative measures (e.g., designated areas). OSHA strived to make the final rule consistent with the construction standard, when appropriate. The record shows a number of employers have workers who perform both general industry and construction activities.

There are several ways in which OSHA made the final rule consistent with the construction fall protection standard. For example, the final rule provides for control flexibility. This rule, like the construction fall protection standard, allows general industry employers, similar to construction employers, to protect workers from fall hazards by choosing from a range of accepted conventional fall protection options. The existing general industry standard does not allow this flexibility and mandated the use of guardrail systems as the primary fall protection method (e.g., see existing § 1910.23(c)).

The 1990 proposed revision of subpart D continued to require the use of guardrail systems. However, in the 2003 notice reopening the record, OSHA acknowledged that it may not be feasible to use guardrails in all workplace situations (68 FR 23528, 23533 (5/2/2003)) and requested comment on whether the Agency should allow employers to use other fall protection systems instead of guardrails. Commenters overwhelmingly favored this approach, which the construction fall protection standard adopted in 1994. In response to comments and OSHA’s history and experience with the construction fall protection standard, the Agency proposed in 2010 to allow employers to select from a range of fall protection options instead of requiring employers to comply with the existing mandate to use guardrail systems.

OSHA is adopting the proposed approach for several reasons. First, the

final rule’s control flexibility reflects longstanding OSHA policy first incorporated in the 1994 construction fall protection standard. OSHA’s history and experience with the construction standard indicates that its control flexibility approach has been effective. In addition, stakeholders responding to the proposed rule overwhelmingly supported this approach and there was little opposition to providing greater flexibility in controlling fall hazards.

Second, the fall protection systems that the final rule allows employers to use (guardrail systems, safety net system, personal fall protection systems) are accepted conventional fall protection systems that OSHA has determined provide an appropriate and equal level of safety. Moreover, allowing employers to select the least costly fall protection system from those controls that provide equal protection also ensures the final rule meets OSH Act requirements that a standard be cost effective (*Cotton Dust*, 452 U.S. at 514 n. 32; *Lockout/Tagout II*, 37 F.3d at 668).

Third, OSHA believes giving employers greater control flexibility in selecting fall protection systems allows them to select the system or method that they determine will work best in the particular work operation and location and draw upon their experience successfully protecting workers from fall hazards. OSHA believes that the process of determining the best fall protection system for the specific work activity will improve safety because employers will need to evaluate the conditions present in each specific workplace and consider factors such as exposure time, availability of appropriate attachment points, and feasibility. Similarly, it also will allow employers to consider and select the fall protection system that enables workers to perform the job most efficiently, thereby reducing workers’ exposure to fall hazards.

Fourth, providing control flexibility allows general industry employers to take advantage of advances in fall protection technology developed since OSHA adopted the existing rule. For example, neither safety net systems nor personal fall protection systems were developed until after OSHA adopted the existing rule.

Fifth, greater control flexibility makes the final rule consistent with the construction fall protection standard, which makes it easier for employers to comply with the final rule and thereby should increase compliance. To illustrate, making the final rule consistent with the construction standard ensures that employers who

have workers engaged in both general industry and construction activities are able to use the same fall and falling object protection while performing both types of activities. It eliminates the need to purchase different fall protection systems when their workers switch from performing general industry operations to construction activities, which ensures that the final rule is a cost-effective approach for eliminating or reducing fall hazards.

Finally, as mentioned, providing greater control flexibility is part of the final rule's comprehensive approach to fall protection that also includes new requirements on system criteria and use; regular inspection, maintenance and repair; and fall hazard and equipment training. OSHA believes this comprehensive approach will provide equivalent or greater protection than the existing rule. As a result, OSHA believes that the additional flexibility and consistency achieved by this final rule in providing fall protection will reduce worker deaths and injuries. OSHA's history and experience with the construction standard confirms that its comprehensive approach to fall protection has been effective.

As mentioned, stakeholders supported incorporating control flexibility in the final rule (e.g., Exs. OSHA-S029-2006-0662-0224; OSHA-S029-2006-0662-0252; OSHA-S029-2006-0662-0306; OSHA-S029-2006-0662-0365). For example, Northrop Grumman Shipbuilding (NGS) commented:

We applaud the agency's work to recognize modern methods and technologies that are now available to ensure adequate fall protection for employees. Our experience is that no single method is effective in all potential fall situations and that a menu of proven methods and techniques . . . works best (Ex. 180).

Uniseal, Inc. said:

OSHA should allow employers to responsibly choose any type of fall protection in proposed Sec. 1910.28 that the employer can demonstrate will be appropriate for the specific work location and activities being performed (Ex. OSHA-S029-2006-0662-0345).

Clear Channel Outdoor agreed, saying: Clear Channel Outdoor and employers in the outdoor advertising industry should be permitted to choose appropriate fall protection, depending upon the location and type of structure. (Ex. OSHA-S029-2006-0662-0308)

The National Grain and Feed Association (NGFA) said:

OSHA should not require guardrails as the primary means of fall protection but allow employers the flexibility to choose the most

appropriate fall protection system that is appropriate to the specific work situation and activities being performed.

[E]mployers evaluate each work situation to determine which option (e.g., guardrails, cages, fall arrest systems, etc.) is the most appropriate and effective (Ex. OSHA-S029-2006-0662-0223).

Duke Energy said OSHA should allow general industry employers to "select from the list of options" like the construction fall protection standard:

The construction industry standard allows employers to select fall protection from a list of options. All of the options provide equivalent protection. Employers should be allowed to use the option that fits the specific situation. The factors that employers use when selecting fall protection options include (1) duration of the job; (2) experience of the workers involved; (3) installation costs; (4) availability of fall protection at the location. There are times when the installation of guardrails is technically "feasible" but adds costs that are unnecessary, since other systems (such as a personal fall arrest system) provide equivalent protection (Ex. OSHA-S029-2006-0662-0310).

Some stakeholders, however, raised concerns about providing greater control flexibility. The American Federation of State, County and Municipal Employees (AFSCME) commented, "Although we understand the need for flexibility, we believe employers should use guardrail systems and other engineering controls whenever possible, as is stated in the existing standard" (Ex. 226). Thomas Kramer of LJB, Inc., expressed concerns that the proposed control flexibility would not be as protective as the existing rule's requirement to use guardrail systems to protect workers from fall hazards, stating:

The hierarchy of control is something that is essential in the area of safety, and OSHA's failure to include something on this . . . is a significant omission. While there are a number of effective abatement options in the proposed regulation—and I understand that many considerations are involved in the cost/benefit analysis for hazard abatement—I still believe that it is a material oversight to remove the hierarchy and state that the options outlined provide "equivalent protection."

The hierarchy of control clearly compares the effectiveness and "defeatability" of a protective system. Employing the hierarchy of control to evaluate abatement options is fundamental, and eliminating its application will lead to more use of a harness and lanyard than ever before. Although this can be an effective way to protect someone from a fall hazard, personal protective equipment is definitely not the safest and is not equal to engineering controls or passive fall protection (Ex. 204).

As discussed above, OSHA believes the comprehensive approach to fall protection that the final rule, like the

construction fall protection standard, incorporates will provide equivalent or greater protection than the existing rule. OSHA is only permitting employers to use those accepted conventional fall protection systems that the Agency has determined to provide an appropriate and equal level of protection. The greater flexibility the final rule affords employers will allow them to select from those fall protection systems that provide equal protection the option that works best in the specific situation and is the most cost-effective protective measure capable of reducing or eliminating fall hazards. Moreover, the comprehensive approach in the final rule, like the construction fall protection standard, recognizes that, in some instances, it may not be possible to use guardrail systems or safety net systems to protect workers from falls. For example, some commenters said employers may not be able to install permanent systems such as guardrails when they do not own the building or structure on which their workers are working. OSHA believes the final rule addresses the concerns of these commenters without limiting employer flexibility or compromising worker safety.

OSHA notes that the final rule also limits fall protection choices in some situations where the Agency determined that guardrail systems are necessary to protect workers from falling. For example, in final paragraphs (b)(4) and (5) of this section, OSHA specifically requires the use of guardrails on dockboards and runways and similar walkways, respectively.

In addition to control flexibility, there are other ways in which OSHA made the final rule consistent with the construction fall protection standard. OSHA increased the consistency between the general industry and construction fall protection standards by including a provision similar to the construction standard addressing work on low-slope roofs (final paragraph (b)(13)). Workers on these walking-working surfaces perform both construction and general industry activities and OSHA believes that uniform requirements should apply to both activities. Final paragraph (b)(13), like the construction fall protection standard, allows employers to use designated areas instead of conventional fall protection systems when workers are performing work that is both infrequent and temporary at least six feet from the edge of a low-slope roof, while also ensuring that employers protect workers working closer to the edge using conventional systems (e.g., guardrail, personal fall arrest, or travel

restraint systems). As mentioned, OSHA believes that an important key to protecting workers is allowing employers the flexibility to select the fall protection system or method that will work best for their particular work activities or operations, thereby allowing employers to consider factors such as exposure time, availability of appropriate attachment points, and feasibility of compliance.

Consistent with the construction standard, the final rule requires that employers also must train their workers working in designated areas in the use of warning lines (see final §§ 1910.29(d) and 1910.30(a)).

Finally, OSHA increased the consistency of the general industry standard with the construction fall protection standard by organizing this final rule in a format that is similar to the construction standard. OSHA believes that the reorganized format will increase employer understanding of, and compliance with, the final rule.

Many commenters supported making the general industry and construction industry fall protection rules consistent (Exs. 111; 157; 165; 176; 212; 225; 236). For example, American Airlines (AA) supported making the general industry and construction standards uniform because they said it is “nonsensical to have different fall protection requirements for similar—and sometimes identical—hazards across construction and general industries” (Ex. 194).

However, Mr. Kramer, of LJB, Inc., expressed doubts about whether making the final rule similar to the construction fall protection standard will produce a significant decrease in fatalities. He claimed that fatality data in the years following adoption of the construction fall protection standard showed an increase in fall fatalities. OSHA does not find his argument convincing. Mr. Kramer does not clearly identify the source or scope of the data. At one point he suggests the data are from BLS, and at another point he indicates the data are from another source. In addition, it is unclear whether the data to which he refers are for construction or for all private industry fatalities. He did not provide any of the data itself. In any event, as explained in more detail in the Analysis of Risk and FEA (Sections II and V), there are a significant number of fall fatalities in general industry, and OSHA believes the final rule will be effective in reducing those numbers.

The final rule also establishes criteria and work practices addressing personal fall protection systems (§ 1910.140). These criteria include minimum strength and load, locking, and

compatibility requirements for components of personal fall protection systems, such as lines (vertical lifelines, self-retracting lines, and travel restraint lines), snaphooks, and anchorages. The work practices include requiring employers to ensure inspection of personal fall protection systems before each use, and to ensure that a competent or qualified person inspects each knot in a lanyard or vertical lifeline. OSHA believes these criteria and work practices, in conjunction with the training and retraining requirements in the final rule, provide a combination of controls and redundancies that will help to ensure that personal fall protection systems are effective in protecting workers from falls hazards.

Paragraph (a)—General

Final paragraph (a)(1), like the proposed provision, requires employers to provide protection for workers exposed to fall and falling object hazards. It also specifies that, unless stated otherwise, the protection employers provide must comply with the criteria and work practices set forth in § 1910.29, Fall protection systems and falling object protection—criteria and practices. In addition, final paragraph (a)(1) clarifies that personal fall protection systems must comply with the criteria and work practices in § 1910.140, Personal fall protection systems.

Fall hazard identification is particularly important when workers work in a “designated area” or under other work situations where employers do not provide conventional fall protection systems. Additionally, when general industry employers contract with other employers to perform jobs and tasks at the worksite, OSHA also requires that the host employer and contract employer work together to identify and address fall hazards. One method of accomplishing this requirement is to follow the guidance specified by appendix B of 29 CFR part 1910, subpart I, Non-Mandatory Compliance Guidelines for Hazard Assessment and Personal Protective Equipment Selection. National consensus standards provide another resource for identifying and controlling fall hazards. For example, ANSI/ASSE Z359.2–2007, Minimum Requirements for a Comprehensive Managed Fall Protection Program, provides procedures for eliminating and controlling fall hazards (Ex. 29).

OSHA notes that the requirements in proposed paragraph (a)(2), which address the strength of walking-working surfaces, have been moved to final § 1910.22(b), which establishes

requirements for maximum intended loads applied to walking-working surfaces. OSHA believes this change more clearly emphasizes that all walking-working surfaces must have the strength and structural integrity to support workers safely, not just those surfaces and work conditions requiring fall protection.

Final paragraph (a)(2) lists seven situations in which the requirements in § 1910.28 do not apply:

- Portable ladders (final paragraph (a)(2)(i));
- When the employer is inspecting, investigating, or assessing workplace conditions or the location at which work is to be performed prior to the start of work or after all work has been completed. However, this exception does not apply when fall protection systems or equipment meeting the requirements of § 1910.29 have been installed and are available for workers to use. If fall protection systems are present, workers must use them while conducting pre-work and post-work inspections, investigations, or assessments of workplace conditions (final paragraph (a)(2)(ii));
- Fall hazards presented by the exposed perimeters of entertainment stages and the exposed perimeters of rail-station platforms (final paragraph (a)(2)(iii));
- Powered platforms covered by § 1910.66(j) (final paragraph (a)(2)(iv));
- Aerial lifts covered by § 1910.67(c)(2)(v) (final paragraph (a)(2)(v));
- Telecommunications work covered by § 1910.268(n)(7) and (n)(8) (final paragraph (a)(2)(vi)); and
- Electric power generation, transmission, and distribution work covered by § 1910.269(g)(2)(i) (final paragraph (a)(2)(vii)).

The first two exceptions, specified in final paragraphs (a)(2)(i) and (ii), are new additions to the final rule. OSHA added language specifically excepting portable ladders to clarify that employers only have to provide fall protection on fixed ladders. The National Chimney Sweep Guild (NCSG) (Exs. 150; 240; 268; 269; 329 (1/18/2011, pgs. 254–348); 365) pointed out that in the proposed rule OSHA did not exclude portable ladders from the duty to have fall protection, and expressed concern that, by default, the rule would cover portable ladders under the “catch-all” provision (final paragraph (b)(15), Walking-working surfaces not otherwise addressed). The fall protection requirements in the proposal were to apply only to fixed ladders, not portable ladders. Therefore, OSHA agrees with NCSG that adding a specific exception

to the final rule clarifies this requirement.

The final rule also adds an exception when workers are inspecting, investigating, or assessing (collectively referred to as “inspecting”) workplace conditions prior to the start of any work or after completing all work. However, once any work begins, employers must provide workers performing inspections (inspectors) with, and ensure that they use, fall protection where required by this section. Moreover, this exception does not apply when properly installed fall protection systems or equipment meeting the requirements of § 1910.29 are available for use. The existing rule does not exclude pre-work or post-work inspections from fall protection requirements. OSHA drew the exception from the construction fall protection standard (§ 1926.500(a)(1)).

Several commenters urged OSHA to add this exception to the final rule (Exs. 111; 150; 157; 176; 177; 212; 225; 240; 268; 269; 329 (1/18/2011, pgs. 254–348); 365). First, some commenters said it was not necessary for workers conducting pre-work or post-work inspections to use fall protection. For example, American Insurance Association (AIA) said the final rule should recognize that certain tasks that workers (*e.g.*, claims adjusters and loss-control personnel) perform on roofs have “lower risks” because “these tasks are usually conducted in good weather and normally expose employees to a fall hazard only for a short time, if at all” (Ex. 157). Allstate Insurance Company (Allstate) agreed, adding that insurance inspectors (and adjusters) only access roofs infrequently to inspect damage (Ex. 212).

Little Mendelson, P.C., said, “Employees who inspect, investigate or assess workplace conditions and perform no physical work should be exempt from the requirements of fall protection, provided the employee has received the training specified in Section 1910.30” (Ex. 111). AIA added that all of their workers who perform inspections receive training in safe roof access, and are well aware of the proximity of unprotected sides (Ex. 157). Allstate also said that workers performing inspections are more aware of their location than other workers (Ex. 212).

A number of commenters said OSHA should add an exception because requiring inspectors to use fall protection would expose them to greater, and additional, hazards (Exs. 111; 150; 157; 177; 212; 225; 240; 268; 365). For instance, Little Mendelson said, “By allowing such employees to perform their inspection duties without

fall protection, OSHA would avoid the greater fall hazards incurred by employees who must access elevations carrying the tools and materials required to install fall protection for the inspectors” (Ex. 111). Commenters also said that requiring inspectors to use fall protection would pose greater hazards because it would expose them to fall hazards for greater periods of time. Little Mendelson said requiring inspectors to use fall protection would expose them to fall hazards for longer than it takes to perform the inspection (Ex. 111). NCSG agreed, explaining that it would take longer to get to, install, and remove anchors than the time it takes to conduct the inspection (Exs. 150; 240; 268; 269; 329 (1/18/2011, pgs. 254–348); 365). NCSG said the vast majority of their work is chimney cleaning and inspection in which chimneys are cleaned from the ground and workers only access the roof for a few minutes to inspect the chimney at the conclusion of the job to verify the cleaning operation is complete (Ex. 150). NCSG also said that chimney sweeps perform pre-inspections on roofs to identify whether repairs or other maintenance work may be needed. The fall protection exception in final paragraph (a)(2)(ii) would cover both of these inspections.

Similarly, Roofing Consultants Institute, Inc. (RCI) said that complying with the proposed rule would require spending increased time on roofs to anchor and position fall protection systems, therefore increasing worker exposure to falls (Ex. 225). AIA, Allstate, Confrere Strategies on behalf of the National Association of Mutual Insurance Companies (Confrere Strategies), and Farmers Insurance Group of Companies (Farmers) also voiced the same argument (Exs. 157; 176; 177; 212).

Several commenters complained that requiring inspectors to use fall protection would be infeasible and “unduly burdensome” (Exs. 150; 157; 176; 177; 212; 235). Allstate said the proposed requirement was infeasible because the insurance company does not own or control the properties that its adjusters inspect and does not have permission to install fall protection systems (Ex. 212). AIA indicated that the proposed requirement was infeasible, and that an exception was necessary for the insurance industry to continue its work. However, AIA did not provide any explanation regarding why the proposed requirement was infeasible (Ex. 157). RCI said the proposed rule was unreasonably burdensome because it did not provide any discernible benefits (Ex. 225).

Two commenters, Allstate and Farmers, indicated that inconsistency between the proposed rule and the construction fall protection standard, and lack of clarity about which standard would apply to inspectors, would cause confusion and pose an unreasonable burden on employers (Exs. 157; 176). Specifically, Allstate believed that the construction exception covered the activities of insurance adjusters, but was unsure whether inspecting damaged property is subject to the general industry rule or the construction rule. Farmers pointed out:

Currently, neither the Proposed Rule nor the construction fall protection requirements make clear whether a claims adjuster’s inspection and assessment of damaged property before and after construction is considered “construction work” covered by 29 CFR § 1926.500(a) or whether such inspection activities would be subject to the General Industry Standards under the Proposed Rule (Ex. 176).

Finally, some commenters said OSHA’s rationale for allowing the exception for the construction industry also should apply to general industry inspectors (Exs. 157; 177; 212; 225). For example, RCI said, “[W]ork practices used by RCI members performing site visits . . . such as [on] roofs would most likely be identical for both general and the construction industry” (Ex. 225). Confrere Strategies said:

The 1994 rationale for the insurance and inspection exception remains today. Subjecting inspectors and adjusters to fall protection standards would be overly burdensome and infeasible and would subject employees to fall hazard for greater periods of time. Incorporation of specific exemption language in Subpart D is consistent with prior regulations, reflects the realities of insurance inspection and claims adjustment operations and would eliminate any potential confusion related to the definition of “construction activities” (Ex. 177).

AIA added, “AIA supports harmonization of the fall protection requirements in the Construction and General Industry Standards. In furtherance of that goal, we recommend incorporating into the proposed rule the exception to fall protection requirements for inspection, investigation and assessment activities contained in the Construction Industry Standard” (Ex. 157).

OSHA recognizes that requiring workers to use fall protection when conducting inspections prior to, and after completion of, work may not be feasible in some isolated or limited situations. For example, as Allstate said, the insurance companies are unlikely to own the structures the inspectors are

inspecting, and it may not be possible to obtain permission to install fall protection equipment, such as anchors (Ex. 212). Therefore, OSHA added a limited exception to the final rule for pre-work and post-work inspections activities.

However, as mentioned earlier, unlike the exception in the construction fall protection standard, final paragraph (a)(2)(ii) does not apply when fall protection systems or equipment already are installed on the structure where an inspector will conduct a pre-work or post-work inspection, that is, when fall protection systems are installed, workers performing pre-work and post-work inspections, like all other workers, must use them.

OSHA believes that limiting the application of the exception to pre-work and post-work is appropriate. The Agency believes that, where fall protection equipment already is installed, there is no reason why inspectors should not use it like all other workers working on the same walking-working surface must. To illustrate, where anchors and self-retracting lifelines meeting the requirements of § 1910.29 already are installed on a roof, OSHA believes that attaching a harness should not increase inspectors' exposure to the fall hazard in any appreciable way, while taking this action ensures that they can safely conduct the inspection. When inspectors have to climb fixed ladders equipped with ladder safety systems or self-retracting lifelines for personal fall arrest systems to inspect damage or assess maintenance needs, OSHA believes it is feasible for these workers to attach their harnesses to the existing equipment without difficulty or increasing exposure time.

OSHA notes that evidence in the record indicates that an increasing number of buildings and fixed ladders are equipped with anchorages and ladder safety or personal fall arrest systems, respectively. Unlike pre-work and post-work inspections in the construction industry, in general industry, buildings and structures already exist and already may have fall protection equipment installed. Therefore, OSHA believes that a number of situations currently exist in which it may be feasible to use fall protection when conducting pre-work and post-work inspections, and that these situations are likely to continue increasing.

The third exception to the requirement to provide fall protection, specified in final paragraph (a)(2)(iii), applies to fall hazards presented by exposed perimeters of entertainment

stages and rail station platforms; OSHA carried this exception over from the proposed rule. The use of guardrails or other fall protection systems could interfere with performances on stage, or create a greater hazard to the performers than would otherwise be present. OSHA recognizes that there may be circumstances when fall protection may be feasible in these occupational settings, and encourages employers in these settings to use fall protection when possible, such as during rehearsals. OSHA did not receive any comments opposing this exception, and adopted it as proposed.

Paragraphs (a)(2)(iv) through (vii), like the proposed rule, specify that the final rule does not apply to powered platforms (§ 1910.66), aerial lifts (§ 1910.67), telecommunications (§ 1910.268), or electric power generation, transmission, and distribution (§ 1910.269). Other general industry standards address those operations and equipment, and include provisions requiring employers to provide and ensure workers have and use fall protection. OSHA received one comment on these exceptions. Ameren Corporation agreed that final § 1910.28 should not apply to work that § 1910.269 covers (Ex. 189). OSHA adopted the proposed exceptions with only minor editorial changes, for clarity.

Paragraph (b)—Protection From Fall Hazards

Final paragraph (b), like the proposed rule, sets forth the requirements on the types of fall protection systems that employers must select and use to protect workers from fall hazards while working in specific workplace areas, situations, and activities (final paragraph (b)(1) through (15)). The final rule allows employers to use any one or more of the fall protection systems listed for the particular area, situation, or activity, including:

- *Guardrail systems*—barriers erected to prevent workers from falling to a lower level (final § 1910.21(b));

- *Safety net systems*—passive fall protection systems that arrest a worker from falling to a lower level when a fall occurs. Employers must install safety net systems as close as practicable below the surface where workers are working, and extend the systems beyond the outermost projection of the workstation;

- *Personal fall protection systems*—a type of conventional fall protection system that protects a worker from falling, or safely arrests a worker's fall if one occurs. They include personal fall arrest, and travel restraint and

positioning systems, but not rest lanyards (final § 1910.140(b));

- *Personal fall arrest systems*—a type of personal fall protection system used to arrest workers from falling to a lower level when a fall occurs. These systems consist of an anchorage, connector, and body harness. A personal fall arrest system also may include a lanyard, deceleration device, lifeline, or combination of these items (final § 1910.140(b));

- *Travel restraint systems*—a type of personal fall protection system used to limit a worker's travel to prevent exposure to a fall hazard. Travel restraint systems consist of a combination of an anchorage, connector, lanyard, and body support. Unlike personal fall arrest systems, travel restraint systems do not support the worker's weight. Rather, the purpose of these systems is to prevent workers from reaching the fall hazard, such as an unprotected side or edge (final § 1910.140(b)).

- *Ladder safety systems*—a system designed to eliminate or reduce the possibility of falling from a fixed ladder. A ladder safety system usually consists of a carrier (*i.e.*, a flexible cable or rigid rail track), a safety sleeve (*i.e.*, a moving component that travels up and down on the carrier), lanyard, connectors, and body harness (final § 1910.21(b));

- *Positioning systems (work-positioning systems)*—a type of personal fall protection system designed to support a worker in a fixed location, on an elevated vertical surface (*e.g.*, fixed ladders), so the worker can work with both hands free (final § 1910.140(b));

- *Handrails*—rails used to provide workers a handhold for support (final § 1910.21(b)); and

- *Designated areas*—a distinct portion of a walking-working surface delineated by a perimeter warning line in which workers may perform work in certain situations without using additional fall protection (final § 1910.21(b)).

OSHA believes each of the fall protection systems listed for a particular situation are effective and appropriate in those situations. In this regard, OSHA notes that the final rule only permits employers to use designated areas on low-slope roofs (final paragraph (b)(13)). The proposed rule permitted employers to use designated areas for unprotected sides and edges (proposed paragraph (b)(1)(ii)), wall openings (proposed paragraph (b)(7)(ii)), and walking-working surfaces not otherwise addressed (proposed paragraph (b)(13)(ii)).

After reviewing the rulemaking record, as well as OSHA's letters of

interpretation addressing the use of controlled access zones and warning line systems under the construction fall protection standard, OSHA believes that designated areas must be limited to only “a few, very specific situations” (see, e.g., letter to Mr. Keith Harkins (11/15/2002)⁴²). To illustrate, the construction standard only permits the use of a warning line system for roofing work on low-slope roofs (§ 1926.501(b)(10)), and the use of controlled access zones for overhand bricklaying and related work (§ 1926.501(b)(9)). The construction standard also allows the use of controlled access zones for some leading edge work, for precast concrete erection, and in residential construction, rather than the broad category of unprotected sides and edges (§ 1926.502(k)), and then only when employers can demonstrate that it is infeasible or creates a greater hazard to use conventional fall protection equipment.

Applying the rationale in the construction standard to general industry, the final rule limits the use of designated areas to work on low-slope roofs (final paragraph (b)(13)). OSHA believes that the use of designated areas is appropriate on flat or gently sloping surfaces or when workers and work are located a safe distance from a fall hazard, such as a roof edge. However, OSHA does not believe that designated areas provide adequate protection from fall hazards on steep or vertical surfaces or for work performed near an unprotected edge or side, such as narrow walking-working surfaces. (See further discussion of designated areas in final paragraph (b)(13), below.)

OSHA received several comments on the use of designated areas. David Hoberg, with DBM Consultants, supported limiting the use of designated areas because “it is a huge opening for abuse” (Ex. 206). He suggested limiting the use of designated areas to those situations that existed prior to publication of this final rule, are unique to the work such that the same work is not done at other locations using standard methods, and when a certified safety professional or professional engineer with experience in the work and conditions approves use of a designated area (Ex. 206). As discussed in more detail below (final § 1910.28(b)(13)), OSHA is limiting the use of designated areas to low-slope roofs and to work more than 6 feet from the edge. Employers may use designated areas for work that is more than 6 feet

and less than 15 feet from the edge if it is both infrequent and temporary. If the work is not temporary or infrequent, the employer may use a designated area if the work is more than 15 feet from the roof edge. The Agency believes this clarification addresses Mr. Hoberg’s concerns.

Several commenters objected to the designated area approach because it was too different from the construction standard’s requirements for residential roofs, and instead asked that OSHA synchronize the general industry requirements with the construction standard for those roofs (See, e.g., 124, 149, 150.). OSHA agrees in general, and the final rule includes a new paragraph (final § 1910.28(b)(1)(ii)) addressing these concerns. Under this provision, employers may implement a fall protection plan meeting the requirements of the construction standard if they can demonstrate that it is not feasible or creates a greater hazard to use guardrail, safety net, or personal fall protection systems on a residential roof.

In addition to establishing fall protection options for specific workplace areas and situations, final paragraph (b) also establishes the height that triggers the employer’s obligation to provide fall protection. The final rule, like the existing and proposed rules, generally requires that employers provide fall protection when workers work at levels that are four feet or more above a lower level. The final rule, like the proposal, defines “lower level” as an area to which a worker could fall (§ 1910.21(b)). The definition also includes examples of lower levels, including ground levels, floors, excavations, pits, tanks, materials, water, equipment, and similar surfaces and structures, or portions thereof.

Employers’ duty to provide fall protection when workers can fall four feet or more to a lower level is not new. As mentioned earlier, the existing rule, which OSHA adopted in 1971, has a four-foot trigger height (e.g., existing § 1910.23(b)(1)(i), (b)(2), (b)(3), (c)(1), (c)(2); § 1910.268(g)). Pursuant to section 6(a) of the OSH Act, OSHA adopted the 4-foot trigger from ANSI A12.1–1967, Safety Requirements on Floor and Wall Openings, Railings and Toe Boards. As far back as 1932, ANSI A12.1 prescribed a 4-foot trigger height. ANSI/ASSE A1264.1–2007, Safety Requirements for Workplace Floor and Wall Openings, Stairs and Railing Systems, also requires the use of fall protection where there is an unprotected side or edge 4 feet or more above a lower level (Ex. 13). Like ANSI A12.1, the ANSI/ASSE A1264.1

standard has specified the 4-foot fall protection height requirement since its inception.

Since OSHA adopted the general industry four-foot trigger, the Agency consistently reinforced the requirement in numerous public statements and Agency interpretations (e.g., letters to Mr. Paul Osborne (May 13, 1980);⁴³ Mr. Anil Desai (September 14, 1990);⁴⁴ M.O. Brown, Jr. (October 22, 1992)⁴⁵). Moreover, as far back as 1932, the ANSI A12.1 standard included the four-foot trigger. Thus, OSHA believes the general industry four-foot trigger is a well-recognized requirement.

In 1994, the construction fall protection standard, with some exceptions, set a six-foot trigger height for construction work (59 FR 40672 (8/19/1994)). In 2003, when OSHA reopened the record for comment on subpart D, comments received by the Agency indicated that some stakeholders mistakenly believed that the general industry fall protection trigger height is the same as the construction fall protection standard. To address this confusion, OSHA clearly pointed out in the 2010 proposed rule that the four-foot trigger height for general industry “has been standard industry practice for more than 75 years” (75 FR 28887).

OSHA did not propose to revise the four-foot trigger height, noting that the existing rule is a long-standing requirement and standard industry practice. OSHA also said the results of a 1978 University of Michigan study supported the four-foot fall protection trigger height (Ex. OSHA–S041–2006–0666–0004). OSHA requested comment on the four-foot trigger height, including information on any recent studies and information that “support or contradict” the four-foot trigger height (75 FR 28887).

A number of commenters supported retaining the existing four-foot trigger height (Exs. 65; 172; 226). In particular, the American Federation of Labor and Congress of Industrial Organizations (AFL–CIO) stated, “The 4-foot rule maintains a long-standing OSHA requirement and industry practice that we believe is important for protecting workers against fall hazards to a lower

⁴³ OSHA letter to Mr. Osborne available at: http://www.osha.gov/pls/oshaweb/owadisp.show_document?p_table=INTERPRETATIONS&p_id=18868.

⁴⁴ OSHA letter to Mr. Desai available at: https://www.osha.gov/pls/oshaweb/owadisp.show_document?p_table=INTERPRETATIONS&p_id=20086.

⁴⁵ OSHA letter to Mr. Brown available at: https://www.osha.gov/pls/oshaweb/owadisp.show_document?p_table=INTERPRETATIONS&p_id=20899.

⁴² OSHA letter to Mr. Keith Harkins available at: https://www.osha.gov/pls/oshaweb/owadisp.show_document?p_table=INTERPRETATIONS&p_id=24552.

level” (Ex. 172). Martin’s Window Cleaning said that “[s]ince it has always been OSHA’s stand that [potential] falls be limited to less than 4 [feet in general industry], then it is imperative that OSHA include requirements for . . . lifeline tie backs . . . in locations that would limit falls to this distance” (Ex. 65). In addition, they said, “OSHA should require that all fall protection systems and suspension systems limit falls to 4 [feet]” (Ex. 65).

The American Society of Safety Engineers (ASSE) urged OSHA to conduct research that would support a single trigger height for fall protection in general industry and construction, noting:

As OSHA ably recognizes in its discussion [in the proposed rule], research supports the conclusion to maintain its current 4-foot trigger height for general industry. In the same discussion, however, OSHA also recognizes that a 6-foot trigger height is the standard for construction. Despite the long-established traditions behind these different trigger heights, we would encourage OSHA to work with NIOSH to determine if appropriate research can be conducted that would help lead the occupational safety and health community to a single trigger height. If a single trigger height could become widely accepted, ASSE believes there would be significant gains in understanding the importance of fall protections and ways to protect employers. Given the continued high incidence of injuries from heights, it would be prudent to at least examine whether a single trigger height would be helpful (Ex. 127).

ORC Mercer also supported a single fall protection trigger height for general industry and construction, although it was “not arguing that OSHA should set the trigger for fall protection to six feet for all general industry work” (Ex. 254). However, they said OSHA needed to provide a “better explanation/justification for the disparity in the trigger for fall protection in General Industry maintenance work versus Construction work,” stating:

The proposed rule retains the historic disparity of a 4-foot trigger for fall protection in General Industry and a 6-foot trigger for fall protection in Construction. Although the proposal makes a number of arguments regarding the history of its adoption of the four-foot trigger for General Industry work and states that the four-foot rule has been used in consensus standards for more than 75 years, OSHA has not addressed the difficulties for employers who may have General Industry maintenance work going on within only a few feet of activities that meet the definition of Construction work. The definition of what constitutes construction work versus work that falls under the General Industry [standard] continues to confuse employers seeking to set a consistent standard in their workplaces. Simply telling a construction contractor (who is performing

work at a manufacturing site) that he must protect his employees whenever they may fall more than four feet above a lower level (because the host employer wishes that all workers on the site to adhere to a uniform standard) is likely to be met with resistance as the construction contractor’s employees will have been trained and equipped to work with the 6-foot trigger. Hence many employers have simply adopted the six-foot trigger for all non-routine or maintenance work (Ex. 254).

ORC Mercer added that “language and guidance for determining the feasibility of fall protection for work that is done between four and six feet above the next lower lever is needed in both the final rule and in any compliance documents that follow the promulgation of this rule” (Ex. 254).

Others stakeholders also supported a single trigger height, but argued that the single height should be six feet instead of four feet (Exs. 165; 202; 236). The Mechanical Contractors Association of America (MCAA) said, “Construction workers performing work at existing facilities often have to comply with both standards, which creates confusion, and therefore, opportunity for unintentional noncompliance” (Ex. 236). MCAA added that making the general industry trigger height consistent with the construction standard “would eliminate the confusion and simplify compliance requirements without compromising worker safety,” noting:

This section proposes to keep the previously established four foot fall protection/prevention rule in place for general industry. However, employers are often unclear about what OSHA considers to be maintenance and repair, which falls under the agency’s general industry standards (29 CFR 1910), vs. construction work, which falls under the construction standards (29 CFR 1926). In addition, inconsistencies between the two sets of standards often require employers to comply with both sets of standards for the same application (Ex. 236).

Mr. Kramer, of LJB, Inc., raised concerns about the availability and effectiveness of personal fall arrest systems in situations where the fall hazard is only four feet, stating:

It is clear from the proposed regulation that a personal fall arrest system can be used in situations where the fall hazard is 4 feet. I acknowledge that it is possible to rig a fall arrest system to protect a worker from a fall where the allowable fall distance is 4 feet. However, without a direct and in-depth discussion on fall clearance requirements, the statement by OSHA can be very misleading. Falls occurring while attached to a horizontal lifeline can result in total fall distances as large as 15 feet. OSHA risks having employers simply provide their employees with a harness, lanyard and anchorage when they are four feet above a lower level. In this case, the employee is not

protected. The stated goal of reducing fatalities and injuries due to a fall has not been achieved and it is clear in these circumstances that a personal fall arrest system does not provide equivalent protection to a guarded platform (Ex. 204).

However, other commenters said there is personal fall protection equipment available that can limit falls to four feet. In this regard, Capital Safety Group (CSG) and the International Safety Equipment Association (ISEA) said:

ASSE is currently working on a standard for self-retracting lanyards that includes a class of [self-retracting line] that when anchored overhead is designed to protect workers in situations where fall clearance is very limited such as the case when exposed to a 4-foot fall. OSHA should include a reference to this standard when it becomes available (Exs. 185; 198).

Comments and testimony submitted in this rulemaking record have not persuaded OSHA that adopting a fall protection trigger height greater than four feet would provide equivalent or greater protection than the current trigger. As mentioned, existing national consensus standards require that employers provide fall protection where unprotected sides or edges are more than four feet above a lower level. Section 6(b)(8) of the OSH Act specifies that OSHA follow the requirements in national consensus standards unless the Agency can show why a rule that differs substantially from consensus standard “will better effectuate the purposes” of the OSH Act than the national consensus standard. None of the stakeholders arguing that OSHA should change its longstanding general industry four-foot trigger height provided any recent studies, data, or other information to support changing the trigger height to six feet. OSHA believes increasing the height at which employers must provide fall protection may expose workers to additional risk of injury, reduce worker safety, and decrease the protection afforded to workers by OSHA’s general industry fall protection standards (75 FR 28887).

With regard to comments arguing that different fall protection trigger heights for general industry and construction would cause confusion and non-compliance, OSHA’s experience and the rulemaking record do not bear that out. The general industry and construction fall protection trigger heights have been in place for years. OSHA’s enforcement experience with both standards does not indicate that employers are confused about or not been able to comply with applicable fall protection height requirements. In addition, stakeholders did not submit comments in this

rulemaking indicating that they currently are experiencing confusion. Given that, OSHA does not believe that reaffirming the current general industry four-foot fall protection height trigger will cause confusion in the future. In any event, OSHA points out that employers will be in compliance with both the general industry and construction fall protection standards if they provide fall protection when workers are working four feet or more above a lower level.

Final paragraph (b), like the proposal, includes the following four exceptions⁴⁶ from the four-foot trigger height:

- When using motorized equipment on dockboards (final paragraph (b)(4)(ii));
- Over dangerous equipment (final paragraph (b)(6));
- Around repair, service, and assembly pits (final paragraph (b)(8)); and
- On fixed ladders (final paragraph (b)(9)).

More specifically, for work performed on dockboards, the final rule establishes a trigger height of greater than 10 feet for guardrails or handrails when dockboards are used solely for materials-handling operations using motorized equipment. For work performed over dangerous equipment, the final rule, like the proposal, requires that employers protect workers from falling onto or into dangerous equipment regardless of the height at which the workers are working above the dangerous equipment. For work around repair, service, and assembly pits, the use of fall protection is not required for pits that are less than 10 feet deep, provided the employer limits access to the edge of the pit to trained, authorized employees, marks the floor around the edge of the pit in contrasting colors (or places a warning line at least 6 feet from the pit edge), and posts readily visible caution signs around the pit that warn workers of the fall hazard. For fixed ladders, the final rule adopts the proposed requirement that employers must provide fall protection when the ladder extends more than 24 feet above a lower level. (See the detailed discussion of these exceptions below.)

As mentioned earlier, final paragraph (b) also adds a new provision for work

on low-slope roofs (final paragraph (b)(13)). In addition, the final rule moves work on platforms used in slaughtering facilities into a separate provision (final paragraph (b)(14)). The proposed rule addressed these platforms as part of proposed paragraph (b)(1), Unprotected sides and edges.

Unprotected sides and edges. Final paragraph (b)(1), like the proposed rule, establishes fall protection requirements employers must follow to protect workers from falling off unprotected sides and edges of walking-working surfaces that are four feet or more above a lower level. The final rule defines “unprotected sides and edges” as any side or edge of a walking-working surface (except at entrances and other points of access) where there is no wall, guardrail system, or stair rail system to protect an employee from falling to a lower level (final § 1910.21(b)).

Final paragraph (b)(1)(i), similar to the construction fall protection standard (§ 1926.501(b)(1)), specifies that employers may use one or more of the following fall protection options to protect workers from fall hazards at unprotected sides and edges:

- Guardrail systems (final paragraph (b)(1)(i)(A));
- Safety net systems (final paragraph (b)(1)(i)(B));
- Personal fall protection systems, such as positioning, travel restraint, and personal fall arrest systems (final paragraph (b)(1)(i)(C)).

Final paragraph (b)(1)(i) differs from the proposed rule in two ways. First, the final rule allows employers to use positioning systems, in addition to using personal fall arrest and travel restraint systems. Neither the proposed rule nor the construction fall protection rule (§ 1926.501(b)(1)) included positioning systems in the list of personal fall protection systems that employers may use. However, OSHA believes positioning systems are effective to protect workers from falling when they are working in a fixed location above a lower level. OSHA notes that some employers equip their workers with both systems, especially when the workers climb and work on fixed ladders. That is, employers provide personal fall arrest systems to protect workers during climbing and positioning systems to protect workers when they work while standing on the ladder.

Second, as discussed, final paragraph (b)(1)(i) eliminates the use of “designated areas” to protect workers from fall hazards on any unprotected side or edge, which proposed paragraph (b)(1)(ii) would have allowed. As discussed, the use of designated areas is

intended for a very few specific and limited situations rather than all unprotected sides or edges.

General industry work on residential roofs. In final paragraph (b)(1)(ii), which was not in the proposed rule, OSHA adds a provision from the construction fall protection standard (§ 1926.501(b)(13)) that applies to construction on residential roofs. Final paragraph (b)(1)(ii) specifies that when employers can demonstrate it is infeasible or creates a greater hazard to use any type of conventional fall protection system (*i.e.*, guardrail, safety net, or personal fall protection system) when working on a residential roof they must take specific alternative measures to eliminate or reduce fall hazards. Specifically, employers must develop and implement a written “fall protection plan,” including other control measures, and training that meet the requirements in the construction standard (29 CFR 1926.502(k) and § 1926.503(a) and (c); STD 03–11–002 Compliance Guidance for Residential Construction (6/6/2011)).

At the outset, and discussed in detail below, OSHA notes that many stakeholders, including NCSG, urged OSHA to add the construction fall protection plan requirements to the final rule (Exs. 149; 150; 240). These stakeholders, many of whom perform both general industry and construction activities, said making the final rule consistent with the construction standard would make it easier for them to protect workers performing both types of activities. In addition, stakeholders indicated the specific requirements of the fall protection plans give employers a clear blueprint for protecting their workers and achieving compliance when conventional fall protection is infeasible or creates a greater hazard.

OSHA limits final paragraph (b)(1)(ii) to work employers perform on “residential roofs.” OSHA’s definition of “residential roof” incorporates the principles established in its Compliance Guidance for Residential Construction (STD 03–11–002 (6/6/2011)):

The Agency’s interpretation of “residential construction” for purposes of 1926.501(b)(13) combines two elements—both of which must be satisfied for a project to fall under that provision: (1) the end-use of the structure being built must be as a home, *i.e.*, a dwelling; and (2) the structure being built must be constructed using traditional wood frame construction materials and methods (although the limited use of structural steel in a predominantly wood-framed home, such as a steel I-beam to help support wood framing, does not disqualify a structure from being considered residential construction). . . .

⁴⁶ For work on scaffolds, the final rule specifies that employers must protect workers from falls in accordance with the construction scaffold standards (29 CFR part 1926, subpart L). The construction scaffold standards (§ 1926.451(g)(1)) require that employers provide fall protection for workers working on a scaffold more than 10 feet above a lower level.

Recently it has become more common to use metal studs for framing in residential construction rather than wood. . . . OSHA will consider it within the bounds of “traditional wood frame construction materials and methods” to use cold-formed sheet metal studs in framing.

And finally, OSHA is aware that many homes and townhouses, especially in the southern and southwestern regions of the country, have usually been built using traditional wood frame construction throughout the structure except for the exterior walls, which are often built with masonry brick or block. . . . Because the same fall protection methods are likely to be used in the construction of homes built with wood framed and masonry brick or block exterior walls, the Agency has decided that it is consistent with the original purpose of 1926.501(b)(13) to treat the construction of residences with masonry brick or block in the exterior walls as residential construction.

In accord with the discussion above, and for purposes of the interpretation of “residential construction” adopted herein, “traditional wood frame construction materials and methods” will be characterized by:

Framing materials: Wood (or equivalent cold-formed sheet metal stud) framing, not steel or concrete; wooden floor joists and roof structures.

Exterior wall structure: Wood (or equivalent cold-formed sheet metal stud) framing or masonry brick or block.

Methods: Traditional wood frame construction techniques.

Consistent with the construction standard, final paragraph (b)(1)(ii) does not apply to nursing homes, hotels, and similar facilities, even though they are homes or dwellings. As OSHA explained in Compliance Guidance for Residential Construction:

Construction of nursing homes, hotels, and similar facilities typically involves the use of the following materials in the framework of the structure: precast concrete, steel I-beams (beyond the limited use of steel I-beams in conjunction with wood framing, described above), rebar, and/or poured concrete. These materials are not used in traditional wood frame construction, and buildings constructed using these materials will not be considered “residential construction” for purposes of § 1926.501(b)(13) (STD 03–11–002 (6/6/2011)).

OSHA does not intend for final paragraph (b)(1)(ii) to apply to low-slope residential roofs. Employers performing work on low-slope residential roofs must comply with final § 1910.28(b)(13), which requires the use of conventional fall protection in certain locations (within 6 feet of the roof edge) and allows employers to use designated areas further from the roof edge. OSHA does not believe these residential roofs pose the same types of hazards and potential feasibility issues as work performed on residential roofs that have a greater slope. OSHA notes that final

paragraph (b)(1)(ii) applies to the vast majority of residential roofs because they do not meet the final rule’s definition of low-slope roof: “a roof having a slope less than or equal to 4 in 12 (vertical to horizontal)” (§ 1910.21(b)).

As mentioned, final paragraph (b)(1)(ii), like the construction standard, requires that employers use a fall protection plan but only where they demonstrate that all of the fall protection systems specified in final paragraph (b)(1)(i) are infeasible or present a greater hazard in a specific location on a residential roof. The final rule adopts the definition of “infeasible” in the construction fall protection standard, which states that “infeasible” means that it is impossible to perform the construction work using a conventional fall protection system (*i.e.*, guardrails, safety net system, or personal fall arrest system) or that it is technologically impossible to use any one of those systems to provide fall protection (§ 1926.500(b)).

To establish that an OSHA standard creates a greater hazard, an employer must prove, among other things, that the hazards of complying with the standard are greater than those of not complying, and no alternative means of employee protection are available (*Bancker Construction Corp., v. Reich*, 31 F.2d 32, 34 (2d Cir. 1994); *Dole v. Williams Enterprises, Inc.*, 876 F.2d 186, 188 (D.C. Cir. 1989)). It is not enough for the employer to show that complying with a standard will create a new hazard. The Occupational Safety and Health Review Commission (the Commission) has held that the employer must establish that complying with a standard would be more dangerous than allowing employees to work without compliance (*Secretary of Labor v. Spancrete Northeast, Inc.*, 16 O.S.H. Cas. (BNA) 1616, *aff.* 40 F.3d 1237 (2d Cir. 1994)) (See further discussion of greater hazard *vis-à-vis* rolling stock and motor vehicles in the explanation of final § 1910.21). OSHA notes that employers must document in the fall protection plan the reasons for their determination of infeasibility or greater hazard (§ 1926.502(k)(5)).

Final paragraph (b)(1)(ii), like the construction standard, includes a note specifying there is a presumption that using at least one of the fall protection systems final paragraph (b)(1)(i) specifies is feasible and will not create a greater hazard. The record includes information and examples of conventional fall protection controls that employers currently are using or are available for work on residential roofs (Exs. 150; 240; 347). For example, the

NCSG acknowledged there are personal fall protection anchorages available that work on residential roofs (Ex. 150).

Some of these systems have been available and in use since OSHA issued the construction fall protection standard in 1994 (59 FR 40694–95). Based on the rulemaking record, OSHA believes there is substantial evidence that employers can protect workers from falling with conventional fall protection systems in virtually all work operations performed on residential roofs. For example, NCSG indicates that it is feasible to use conventional fall protection in substantial and major installation and repair jobs. Thus, OSHA believes it is appropriate to include the note to underscore that employers have the burden to prove in the particular roof operation all of the controls in final paragraph (b)(1)(i) are infeasible or pose a greater hazard.⁴⁷ If those criteria are satisfied, employers must implement:

- A written fall protection plan that meets the requirements of § 1926.502(k), including implementing other control measures (§ 1926.502(k)(6) and (8)); and
- Training that meets the requirements of § 1926.503(a) and (c).

Section 1926.502(k) specifies that the employer’s fall protection plan must:

- Be prepared by and have any changes approved by a “qualified” person (§ 1926.502(k)(1) and (2)). The final rule defines qualified as a person who, by possession of a recognized degree, certificate, or professional standing, or who, by extensive knowledge, training, and experience has successfully demonstrated the ability to solve or resolve problems relating to the subject matter, the work, or the product (final § 1910.21(b));

- Be developed specifically for the site where the employer will perform work on residential roofs (§ 1926.502(k)(1));

- Be maintained up to date (§ 1926.502(k)(1)), which OSHA said in the construction fall protection standard “provides clear notice to employers that they have an ongoing responsibility” to monitor conditions and address any changes or deficiencies (59 FR 40718);

- Be maintained at the job site (§ 1926.502(k)(1) and (3)), which gives workers the opportunity to inspect the fall protection plan and provides them with needed reassurance that the employer is taking appropriate measures to reduce or eliminate exposure to fall hazards when conventional fall

⁴⁷ Employer claims that standards are infeasible or create a greater hazard are affirmative defenses that employers have the burden of proving in citation cases (OSHA Field Operation Manual, Chapter 5, Section VI).

protection cannot be used (59 FR 40719);

- Be implemented under the supervision of a “competent person” (§ 1926.502(k)(4)). The construction standard defines competent person as a person who is capable of identifying existing and predictable hazards in the surrounding or working conditions which are unsanitary, hazardous, or dangerous to employees, and who has authorization to take prompt corrective measures to eliminate them (§ 1926.32(f));
- Identify each location where conventional fall protection cannot be used and document the reasons why the use of conventional fall protection systems is infeasible or would create a greater hazard (§ 1926.502(k)(5) and (7)).⁴⁸ OSHA explained in the preamble to the construction fall protection standard that requiring employers to make a close examination helps to ensure their decision is justified and has an objective basis (59 FR 40719). A closer examination also ensures that employers have not overlooked locations or operations where conventional fall protection can be used (59 FR 40719);
- Discuss other measures that the employer will take to eliminate or reduce the fall hazard for workers where conventional fall protection is infeasible or creates a greater hazard (§ 1926.502(k)(6));
- Implement control measures to reduce or eliminate hazards or implement a safety monitoring system that complies with § 1926.502(h) (§ 1926.502(k)(8));
- State the name or other method of identification for each worker who works in a location where a fall protection plan is implemented (§ 1926.502(k)(9)); and
- Investigate the circumstances of any fall or other serious incident that occurs to determine whether the employer needs to change the fall protection plan and implement those changes (§ 1926.502(k)(10)).

In the preamble to the construction fall protection standard, OSHA said the

⁴⁸ OSHA notes that the construction fall protection standard requires employers to classify each location in which conventional fall protection cannot be used as a “controlled access zone” and follow the requirements for controlled access zones in § 1926.502(g) (§ 1926.502(k)(7)). Unlike the construction fall protection standard, the general industry final rule does not permit the use of controlled access zones. Therefore, the final rule does not require employers to comply with the controlled access zones requirements in § 1926.502(k)(7), such as erecting a flagged control line around the entire length of the unprotected edge, in locations where the employer has demonstrated that conventional fall protection cannot be used.

fall protection plan requirements gives employers a “clear direction” about what they must do and how they must proceed if conventional fall protection cannot be used (59 FR 40718). Requiring employers to comply with all of the requirements of the fall protection plan, including implementing other control measures, reflects the Agency’s position that any deviation from the general requirements for fall protection must be construed as narrowly as possible” (59 FR 40720). OSHA believes that requiring employers to strictly comply with all of the requirements in § 1926.502(k) when conventional fall protection is not feasible or creates a greater hazard “will provide the best opportunity to avert employee injury and death” (59 FR 40718).

The construction fall protection standard requires that employers develop and implement a fall protection plan for the specific site where they are performing work on a residential roof (§ 1926.502(k)(1)). OSHA notes that a fall protection plan an employer develops for repetitive use for a particular style or model of a residential structure will be considered site-specific for other sites, but only if the plan “fully addresses all issues related to fall protection at that particular site” (STD 02–11–002). For example, chimney sweep companies may use a fall protection plan they develop for a particular type of residential roof (e.g., tile, metal) for other roofs of that type rather than developing a new plan for each residence. Additionally, where a roof is similar to others for which the employer has a fall protection plan, the employer may modify an existing plan instead of developing a new one. However, where the roofs are not the same type or involve different specifications or working conditions, employers must develop and implement a fall protection plan that is specific to the site.

OSHA stresses that after employers have identified where and why conventional fall protection cannot be used (§ 1926.502(k)(5)), it will not be acceptable for employers’ fall protection plans to simply state that they will not be implementing any measures to reduce or eliminate the fall hazard in those locations. Employers must implement other measures to reduce or eliminate fall hazards for workers in those locations (§ 1926.502(k)(6)). The construction fall protection standard identifies a number of measures employers can use to reduce fall hazards when conventional fall protection cannot be used, such as scaffolds, ladders, bucket trucks, and vehicle mounted platforms (§ 1926.502(k)(6)).

To reduce the risk of falls in “ladder to roof transitions,” which NCSG said was “one of the highest hazards,” employers can use equipment (e.g., quivers, backpacks, rope pull) to lift materials and tools instead of carrying them up on ladders. Other measures include safe work practices (e.g., workers positioning themselves so their backs are not to the fall hazard, not working in adverse weather), safety screens (59 FR 40720), scaffold platforms (Ex. 150), and fall hazard training specific to residential roofs.

Stakeholders who recommended adding the fall protection plan provision to the final rule, indicate that they are using the measures identified above (Exs. 150; 342). NCSG, for example, said they use scaffolds and bucket trucks for some chimney sweep operations, particularly significant and major repairs and installations that may take days to a week to complete (Ex. 329 (1/18/2011), pgs. 268–69, 278–80). Chimney sweep companies also work from ladders where possible because, according to NCSG, doing so reduces the fall hazards associated with transitioning from the ladder to the roof (Ex. 150).

Where no other measures can be implemented, the construction fall protection standard requires that employers implement a safety monitoring system that complies with § 1926.502(h). In the preamble to the construction fall protection standard, OSHA indicated that using safety monitoring system is a last resort “when no other, more protective measures can be implemented” (59 FR 40719–20 (“OSHA has determined that the employer must do what it can to minimize exposure to fall hazards before turning to the use of safety monitoring systems”)).

Section 1926.502(h)(1) requires that safety monitoring systems must designate a competent person to be the safety monitor for employees working in areas where no other fall protection measures are used. Section 1926.502(h)(1) also specifies, among other things, that safety monitors must be on the same walking-working surface be within visual sight of workers, close enough to orally communicate with the workers they are monitoring, and not have any other responsibilities that could take their attention away from the workers they are monitoring. In addition, safety monitors must warn workers when it appears that the workers are not aware of fall hazard or are acting in an unsafe manner.

OSHA believes that many employers will not use safety monitoring systems as alternate control measures because

they assign one-worker jobs and a safety monitoring system requires at least two workers at each work location. NCSG said, for instance, that one-person jobs constitute the majority of their work (Ex. 150).

In addition to implementing other measures to eliminate or reduce worker exposure to fall hazards, final paragraph (b)(1)(ii) also requires that employers using fall protection plans must develop and implement a training program and retraining for each employee who works in a location where conventional fall protection cannot be used. The training must meet the requirements in § 1926.503(a) and (c). Section 1926.503(a) requires that employers ensure, among other things, their fall protection plan training program “enables each employee to recognize the hazards of falling and . . . train each employee in the procedures to be followed in order to minimize the hazards” (§ 1926.503(a)(1)). The retraining requirements in § 1926.503(c) are essentially the same as those in final § 1910.30(c).

As stated above, OSHA believes, based on the rulemaking record and the Agency’s experience with the construction fall protection standard, that in most, if not virtually all, jobs performed on residential roofs employers can protect workers from falls by using conventional fall protection systems (*i.e.*, guardrail systems, safety net systems, personal fall protection systems). That said, OSHA has decided to add paragraph (b)(1)(ii) to the final rule for two reasons: (1) To make the final rule consistent with the construction fall protection standard, which is one of the stated goals of this rulemaking, and (2) to address stakeholder concerns about the feasibility of conventional fall protection in certain residential roof operations.

Allowing employers who perform both general industry and construction activities to follow the same standard makes it easier and more efficient for employers to safely perform both types of activities, and thereby, facilitates compliance and reduces potential for confusion about which standards apply to a particular operation.

Throughout this rulemaking, stakeholders have repeatedly urged OSHA to harmonize the general industry and construction fall protection standards, particularly with respect to the fall protection plan requirements in the construction standard (Exs. 124; 149; 150; 240; 329 (1/18/2011, p. 279); 342; 365). For example, SBA Office of Advocacy said small business representatives (SERs)

who attended a roundtable discussion on the proposed rule, recommended that “OSHA should further synchronize the proposed general industry rule with the existing construction standard” (Ex. 124). According to SBA Office of Advocacy, SERs expressed concern that “[t]wo employees could be working side by side on similar tasks, but one could be covered by the general industry standard and the other by the construction standard” (Ex. 124). SBA Office of Advocacy added that SERs were confused about “the difference between maintenance and repair (general industry) and construction activities” and “which standards applied under what circumstances” (Ex. 124). To illustrate, NCSG said it can be difficult to figure out whether certain chimney sweeps operations (*e.g.*, replacing chimney caps, repairing roof flashing) are maintenance (general industry) or construction activities. OSHA believes that making the general industry and construction fall protection standards consistent resolves those concerns.

OSHA notes the construction fall protection plan requirements have been in place since 1994, therefore, general industry employers who perform construction activities (*e.g.*, chimney sweep companies) have significant experience developing and implementing fall protection plans, other control measures, and training in jobs where conventional fall protection cannot be used. OSHA has not received any reports that these employers have experienced difficulty complying with the fall protection plans requirements in the construction standard. Rather, these stakeholders repeatedly urged OSHA to allow them to implement fall protection plans when they satisfy the criteria in final paragraph (b)(1)(ii) regardless of whether the activity is general industry or construction.

OSHA also is adopting final paragraph (b)(1)(ii) to address the concerns stakeholders raised (*e.g.*, Exs. 149; 150; 240). NCSG, for instance, commented that using conventional fall protection systems on residential roofs is “technologically and/or economically infeasible” “for the great majority of tasks performed by [chimney] sweeps” and “threatens both the continuing viability of the industry and the availability of chimney inspection, sweeping, and repair services at affordable prices” (Ex. 150).

NCSG and the National Association of Home Builders (NAHB) both argued that it is not possible to use conventional fall protection systems on residential roofs because there are not suitable attachment or anchorage points and it is

not possible to install them (Exs. 149; 150; 342). For instance, NAHB said it is not possible to penetrate tile or metal roofs to secure an anchor (Ex. 149). In addition, NAHB and NCSG said homeowners would not permit contractors to nail anchorages into the roof or install guardrails because of concern that such installation would cause damage.

OSHA notes that NCSG’s own materials suggest some flexibility in the use of nails in particular. In their “successful chimney sweep training” booklet, NCSG recommends securing ladders by “driv[ing] a nail into the roof and secur[ing] the ladder with rope. If you choose this method, remember to remove the nail and to seal the hole before leaving the rooftop” (Ex. 342). NCSG offers no explanation as to why homeowners would allow ladders to be secured to the roof with nails but not roof anchorages. In addition, CSG and ISEA said temporary roof anchors can be mounted to common roof structural materials by clamps or screws, which would not damage the roof (Exs. 185; 198).

OSHA recognizes that, where homeowners will not allow employers to install temporary or permanent anchors or other fall protection (*e.g.*, guardrails) and all other conventional fall protection systems are infeasible, implementing a fall protection plan, other measures to eliminate or reduce fall hazards, and training “will provide the best opportunity to avert employee injury and death” (59 FR 40718). That said, OSHA notes that attaching personal fall protection systems to a roof anchorage may not be the only available method of anchoring those systems. However, to the extent other types of anchors or attachment devices are or become available, employers would have to demonstrate that those devices are infeasible in order to satisfy the criteria in final paragraph (b)(1)(ii).

As mentioned, stakeholders, including NCSG, have argued they should be allowed to use fall protection plans and other control measures where they demonstrate conventional fall protection would create a greater hazard. NCSG said requiring the use of conventional fall protection would result in extended exposure to fall hazards, and thereby create a greater hazard, because it may take longer to install and remove fall protection (*e.g.*, roof anchors for personal fall protection) than to perform the work. NCSG said chimney cleaning and inspection involves accessing the roof for only 5 to 20 minutes and minor repairs (*e.g.*, replacing a chimney cap, minor flashing repair) typically requires the chimney

sweep to work on the roof for 20 minutes to 2 hours (Ex. 150). By contrast, they said installing anchors would take 45 to 90 minutes (Ex. 150). However, Tom Wolner, of CSG, said that employers can install temporary nail-on roof anchors in “probably less than 10 minutes” (Ex. 329 (1/18/2011, p. 107)).

Stakeholders also said requiring the use of conventional fall protection in residential rooftop operations would create a greater hazard because workers would have to carry extra equipment to the roof, which they said would “increase the number of ground to roof trips” (Ex. 150). NCSG pointed out that chimney cleaning and inspection typically is done in one climb; however, they also acknowledged that fall protection can be brought to the roof during the initial climb and even minor repairs and installations can involve multiple climbs (Ex. 150). As the examples above illustrate, rooftop work varies widely in the duration and climbs. Employers will have to demonstrate that using conventional fall protection in the specific operation makes it more dangerous for workers than working without that protection.

Some commenters opposed allowing any exemptions from using conventional fall protection systems (Exs. 185; 198; 329 (1/18/2001), pgs. 82–83, 107). For example, Tom Wolner, of CSG, said:

Certain segments within general industry have requested that OSHA provide broad exemptions from proposed fall protection regulations, by citing things such as hardships that the use of fall protection would create, safe work histories or feasibility concerns. Capital Safety is opposed to granting such general exemptions within the regulation. It is our opinion that it is feasible and practical to provide workers with active or passive means of fall protection in nearly every work situation. A variety of all fall protection equipment available today, combined with our ability and the ability of others like us within the fall protection industry to customize or tailor fall protection equipment to specific needs often eliminates the need for exemptions (Ex. 329 (1/18/2011, pgs. 82–83)).

OSHA agrees with Mr. Wolner that it is feasible for employers to provide workers with conventional fall protection systems in “nearly every work situation.” However, OSHA does not agree with Mr. Wolner that final paragraph (b)(1)(ii) is an overly broad exemption or unprecedented. In enforcement action, employers always are permitted to raise affirmative defenses, such as a claim that the required controls are not feasible or pose a greater hazard.

Final paragraph (b)(1)(iii), similar to proposed paragraph (b)(1)(vi), excepts

employers from providing the fall protection specified in final paragraph (b)(1)(i) when employers can demonstrate that it is not feasible for workers to use fall protection on the working side of platforms used at loading racks, loading docks, and teeming platforms. The “working side” is the side of the platform where workers are in the process of performing a work operation. The final rule, similar to the proposed rule, specifies that the working side exception to providing fall protection only applies when the employer demonstrates infeasibility and:

- The work operation for which fall protection is infeasible is in process (final paragraph (b)(1)(iii)(A));
 - The employer limits access to the platform to “authorized” workers (final paragraph (b)(1)(iii)(B)), which the final rule defines as a worker who the employer assigns to perform a specific type of duty, or allows to be in a specific location or area (final § 1910.21(b)); and
 - The employer trains authorized workers in accordance with final § 1910.30 (final paragraph (b)(1)(iii)(C)).
- Section 1910.30 requires, among other things, that employers train workers, including authorized workers, to recognize fall hazards and the procedures to follow to minimize them.

OSHA notes that, in limited cases, it may not be possible for workers to perform work operations if fall protection, such as guardrails, interferes with access to the work operation. However, as the final rule specifies, the issue of blocking access to the work operation is a concern only when workers are in the process of performing the work operation. As a result, fall protection, such as guardrails, must be in place or used when workers are not performing a work operation on the working side of a platform. OSHA believes that fall protection does not interfere with performing tasks such as maintenance, cleaning, and similar tasks; therefore, when workers are performing these tasks, employers must provide fall protection.

Final paragraph (b)(1)(iii) differs from the proposal in two respects. First, the final rule deletes the proposed exception for the “working side” of slaughtering facility platforms (proposed paragraph (b)(1)(iv)). Based on evidence in the record, OSHA decided to regulate those platforms separately in final paragraph (b)(14).

Second, the exception in the final rule only applies when the employer demonstrates that no fall protection system is feasible. The proposed rule applied the exception when the employer demonstrates guardrail

systems are not feasible (proposed paragraph (b)(1)(vi)). Therefore, to the extent fall protection systems other than guardrails are feasible, such as travel restraint or personal fall arrest systems, the employer would have to provide those systems and the exception would not apply.

Stacked materials. In the proposed rule, OSHA raised an issue about whether there is a need to promulgate specific requirements to address the use of fall protection when employees work and climb four feet or more above a lower level on stacked materials, such as stacks of steel and precast concrete products that are being stored or loaded onto motor vehicles and rail cars for transport (75 FR 28868). OSHA noted in the proposed rule that the Agency uses § 1910.23, § 1910.132 and the general duty clause (29 U.S.C. 654(a)(1)) to protect workers who climb and stand on stacked materials from falling (75 FR 28868).

By 2004, the American Iron and Steel Institute (AISI) and Precast/Prestressed Concrete Institute (PCI) had raised the issue of fall protection on stacked materials (75 FR 28868; Exs. 5; 41). In general, they both said using fall protection, such as “guardrails or tie-off protection,” on stacked materials was infeasible or creates a greater hazard (75 FR 28868). AISI said workers at steel and steel product companies “need to stand on ‘stacks’ of product that have a large surface area in order to rig bundles for crane lifts and similar activities” or “[load] products onto truck trailers and railcars” (Ex. 5, AISI’s comments on the Office of Management and Budget “Draft Report to Congress on the Costs and Benefits of Federal Regulations”). They characterized the solutions OSHA recommended to protect those workers (*i.e.*, guardrails around stacked materials, magnet cranes, and safety lines around vehicle trailers and rail cars) as “not feasible” and ones that could “create its own serious safety hazard.” For example, AISI said safety lines would interfere with movement of the product and magnet cranes cannot connect to single bundles.

PCI, in a January 3, 2000, letter requesting an exception from existing fall protection requirements for loading/unloading precast concrete products on motor vehicles and for stacking, storing, and loading/unloading precast concrete products in the plant, said workers need to access the top of concrete products for only “very short periods of time” to connect/disconnect lifting devices or rigging (Ex. 41). They said installing a fall protection system, by contrast, would expose employees to fall hazards for “an extended period of time” and,

therefore, poses a greater hazard (Ex. 41). PCI also pointed out that the OSHA construction fall protection standard does not require that workers use fall protection when unloading precast concrete at construction sites (Ex. 41).⁴⁹

AISI and PCI recommended that OSHA allow employers to use alternative measures, such as safe work practices and training, including a “mentor system hands-on process for training” (Exs. 5; 41). AISI said OSHA should require guardrails or tie-off protection only “where practical” and be permitted to use an “alternative practice” and provide training where it is not (Ex. 5). However, AISI did not identify any alternative practices that would provide adequate protection for employees working on stacked materials. PCI said employers should be allowed to provide “individual instruction as well as have a mentor system hands on training process” instead using fall protection systems on stacked materials (Ex. 41). PCI also recommended that employees perform “corrective and detail work” at the ground level or from a ladder or mobile-elevating work platform instead of on the stacked materials.

OSHA received a number of comments in response to the proposed rule, most of which supported requiring the use of fall protection on stacked materials (Exs. 127; 155; 161; 185; 198; 205; 238). For example, ASSE stated:

ASSE cannot agree with “some commentators (who) have recommended that OSHA allow the use of safe work practices by trained employees in lieu of conventional fall protection for certain activities.” . . . If employers are going to ask employees to climb on stacked materials where there are fall hazards and, typically, exposure to falls off the sides to lower levels, employers have the duty to warn, train and protect workers from falls. In our members’ experience, this is not infeasible or unreasonable to ask (Ex. 127).

The Society of Professional Rope Access Technicians (SPRAT) said “the prevalence of incidents that have occurred in these situations” warrants a requirement to use “fall protection of some sort” on stacked materials (Ex. 205). SPRAT recommended allowing employers to use industrial rope access systems (IRAS) to protect employees because they said it would mitigate any difficulty or impossibility of using “measures previously recognized by OSHA as being ‘conventional’ ” (Ex. 205). SPRAT further recommended:

[I]f OSHA’s language toward protection against falls were less method-specific and more results-oriented, competent and qualified persons would have greater latitude in creating protective systems that would be very protective without having to use a proscribed method. OSHA would be well-advised to permit use of such systems so long as they are approved by a Qualified Person, created by a Competent Person, and appropriate training [is] provided to the Authorized Person (Ex. 205).

OSHA did not propose to cover IRAS and the final rule clarifies that IRAS are not rope descent systems (§ 1910.21(b)). Given that, OSHA is not adopting SPRAT’s recommendations.

Several commenters said fall protection systems to protect employees working on stacked materials are feasible and currently in use in general industry (Exs. 155; 185; 198). For instance, ISEA and CSG said fall protection manufacturers have developed and are supplying employers with such systems, including “trailer-mounted systems, A-frames, rope grab systems, and ropes at tie-off points” (Exs. 185; 198). They added that manufacturers also create custom fall protection systems (Exs. 185; 198). Ellis Fall Safety Solutions (Ellis) said that temporary and permanent wheeled and fork-lifted devices with railed personal fall protection anchorages are available for loading/unloading operations and should be required for stacked materials (Ex. 155; *see also* 148; 158; 198; 355–2). Ellis also pointed out that these systems can provide fall protection over a large surface area (*i.e.*, “up to 30 ft.”) (Ex. 155).

PCI and the International Sign Association (ISA), in response to the proposed rule, submitted comments opposing any requirement for fall protection on stacked materials (Exs. 161; 238). PCI said in the 14 years since their request for an exception from the existing fall protection requirements they had “not learned of any system or device” that would change their position that requiring the use of fall protection on stacked materials is infeasible and would create a greater hazard (Ex. 238).

ISA, like PCI and AISI, argued that it is infeasible to require the use of fall protection on stacked cargo and motor vehicles (Ex. 161). In particular, ISA said permanent attachment of fall protection equipment to motor vehicles is not feasible because the area of the truck bed normally available for walking or working is usually quite small and such equipment would interfere with the utility of trucks as cargo-carrying vehicles. Like PCI and AISI, ISA also recommended that OSHA “should

provide flexibility for employers in terms of implementing alternative practices, appropriate training, or both” (Ex. 161).

ISA also appeared to suggest that installing fall protection for employees working on stacked materials would create a greater hazard. ISA said employees stand or work on stacked materials only “occasionally” and “temporarily” to perform operations that “are strictly associated with rigging of cargo items for hoisting,” implying that rigging stacked cargo only exposes employees to fall hazards for a very brief period of time compared to the time necessary to install fall protection systems (Ex. 161).

After reviewing the rulemaking record, OSHA does not agree that requiring fall protection on stacked materials is infeasible or could create a greater hazard. OSHA finds there is substantial evidence showing that a number of fall protection systems for stacked materials are available and already are in use in general industry (Exs. 155; 185; 198). For example, commenters said wheeled, trailer-mounted and fork-lifted overhead anchor and retractable line systems are available and in use to protect employees working on stacked materials (Exs. 155; 185; 198. *See also, e.g.*, Exs. 148; 158; 355–2; OSHA–S029–2006–0662–0373). These stand-alone systems can be used for stacking, storing, and loading/unloading stacked materials in open yards and plants as well as for loading/unloading stacked materials on rolling stock and motor vehicles (*e.g.*, Ex. 355–2). In addition, the record shows that other fall protection systems employers use for loading/unloading stacked cargo on rolling stock and motor vehicles also work for materials that are stacked or stored in yards or plants. These systems include mobile work platforms, scissor lifts and stairs equipped with railings/guardrails that allow workers to access stacked materials without standing on them (*e.g.*, Exs. 63; 124; 169; 181; 335; OSHA–S029–2006–0662–0208; OSHA–S029–2006–0662–0227; OSHA–S029–2006–0662–0350; OSHA–S029–2006–0662–0373).

Finally, OSHA also concludes that the final rule does not need to include specific or separate requirements addressing stacked materials. OSHA believe that final § 1910.28(b)(1) (Unprotected sides and edges) and (b)(15) (Walking-working surfaces not otherwise addressed) adequately address fall protection on stacked materials.

Hoist areas. Final paragraph (b)(2), like the proposed rule, establishes fall

⁴⁹OSHA notes that the definition of “walking-working surface” in the construction fall protection standard does not include rolling stock and motor vehicles (29 CFR 1926.500(b)).

protection requirements for workers who work in hoist areas that are four feet or more above a lower level. The final rule defines a “hoist area” as an elevated access opening to a walking-working surface through which equipment or materials are loaded or received (final § 1910.21(b)).

Final paragraph (b)(2)(i) requires employers to protect workers in hoist areas from falls by:

- Guardrail systems (final paragraph (b)(2)(i)(A));
- Personal fall arrest systems (final paragraph (b)(2)(i)(B)); or
- Travel restraint systems (final paragraph (b)(2)(i)(C)).

The construction fall protection standard includes a similar provision requiring that employers provide guardrail or personal fall arrest systems to protect workers in hoist areas that are six feet or more above a lower level (§ 1926.501(b)(3)). This final rule provides greater control flexibility than the construction standard because it also allows employers to provide travel restraint systems to protect workers. OSHA received no comments on the proposed provision and it is finalized as discussed.

Final paragraph (b)(2)(ii), like the proposed and construction rules (§ 1926.501(b)(3)), requires that, if removing any portion of a guardrail system, gate, or chains and if the worker leans through or over the edge of the access opening to facilitate hoisting, the employer must protect the worker from falling by a personal fall arrest system. The proposed rule required that employers provide “grab handles” on each side of a hoist area opening, in addition to a personal fall arrest system, if removing the guardrail, gate, or chains and if the worker leans out the access opening. The existing rule does not have a specific provision addressing hoist areas. However, the existing provisions on wall openings and holes requires that both sides of openings and holes have grab handles if the rail, half door, or other equivalent barrier is removed (existing § 1910.23(b)(1)). In addition, where the structure has extension platforms onto which employers may place hoisted materials, the existing rule requires that employers provide side rails or equivalent guards to protect workers (existing § 1910.23(b)(ii)). OSHA notes that it adopted the existing rule in 1971, before personal fall arrest systems were widely available.

OSHA only received one comment on the proposed provision. Ameren recommended that OSHA define what would qualify as a grab handle to ensure the final rule does not result in confusion or misinterpretation (Ex. 189).

After further consideration, OSHA believes it is not necessary for employers to provide grab handles in addition to personal fall arrest systems if removing guardrails, gates, or chains and if workers look through or over the edge of an access opening to facilitate hoisting. OSHA believes that personal fall arrest systems provide adequate worker protection, and better protection than grab handles, therefore, OSHA does not carry forward the proposed requirement on grab handles. Of course, employers are free to provide grab handles or other handholds in addition to personal fall arrest systems in those situations. OSHA believes that the revisions in the final rule address Ameren’s concern and the provision is finalized as discussed.

Final paragraph (b)(2)(iii), specifies that if grab handles are installed at hoist areas, they must meet the requirements of § 1910.29(l). Employers are not required to install grab handles at hoist areas; however, if they do install grab handles, the handles must meet the criteria specified in § 1910.29(l). Although OSHA believes it is not necessary to install grab handles at hoist areas when workers use a personal fall arrest system, the Agency recognizes grab handles can provide some security when workers must lean out from a hoist area. In those cases, OSHA believes it is important for grab handles to be of a certain size, have sufficient clearance, and be capable of withstanding the forces placed on them.

Holes. Final paragraph (b)(3) consolidates the proposed requirements to protect workers from falls associated with holes (proposed paragraph (b)(3)) and floor holes (proposed paragraph (b)(14)), and requires that employers protect workers from falling into or through any hole, including skylights, stairway floor holes, ladderway floor holes, hatchway and chute-floor holes, and other holes on roofs. The final rule defines a “hole” as a gap or open space in a floor, roof, horizontal walking-working surface, or other similar surface that is at least 2 inches in its least dimension (final § 1910.21(b)). Although skylights may be covered by screens or other material, for the purposes of this definition and the final rule, OSHA classifies skylights as holes. Falling into a hole or tripping and possibly falling due to a hole in a walking-working surface may injure or kill a worker.

OSHA believes that consolidating the requirements for protecting workers from falling into or tripping on a hole is appropriate because the hazards generally associated with these conditions, and the methods to address these hazards, are the same. Moreover,

consolidating the provisions makes the final rule easier to understand and follow, which will enhance employer compliance.

In the final rule, OSHA moved the proposed requirement (proposed paragraph (b)(3)(iii)) to protect workers on walking-working surfaces from being hit by objects falling through overhead holes to final paragraph (c), Protection from falling objects. The final rule consolidates all requirements addressing falling object hazards in final paragraph (c).

OSHA received one general comment on the proposed requirements to protect workers from falling or stepping into, or tripping on, holes. Ellis Fall Safety Solutions (Ellis) said the final rule should require that employers not leave holes exposed or uncovered for more than two minutes and assign a “standby person” to be present to warn workers about the hole until employers cover or barricade the hole (Ex. 155). Ellis also said the final rule should require that employers use two means to protect employers from falling into holes as a way “to safeguard the next trade or planned work” (Ex. 155). For example, Ellis suggested that employers cover the hole with a plywood board as the primary means of protection and, as the secondary protection, attach a net to a bar joist underneath the hole using a scissor lift. OSHA believes the final rule provides a reasonable and appropriate level of protection. Any of the fall protection systems specified by the final rule will protect workers from falling, tripping, or stepping into holes. OSHA believes the final rule already ensures the “next trade” is safeguarded from holes. The final rule requires that all employers in any trade must conduct inspections of walking-working surfaces and maintain those surfaces in a safe condition before allowing workers to work there (final § 1910.22(d)(1)). OSHA notes that employers are free to use more than one measure to protect workers from hazards associated with holes.

Final paragraph (b)(3)(i) requires that employers ensure workers are protected from falling through any hole (including skylights) that is four feet or more above a lower level using one or more of the following:

- A cover over the hole (paragraph (b)(3)(i)(A));
- A guardrail system around the hole (paragraph (b)(3)(i)(B));
- A travel restraint system (paragraph (b)(3)(i)(C)); or
- A personal fall arrest system (paragraph (b)(3)(i)(D)).

Final paragraph (b)(3)(i) is the same as the proposed rule, and provides greater

control flexibility than the existing general industry and construction fall protection rules (existing § 1910.23(a)(4), (8), and (9), and § 1926.501(b)(4)). The existing general industry rule only allows employers to guard holes using standard railings (guardrails) or, in some situations, a cover. The construction rule does not include travel restraint systems as a fall protection option to protect workers from falling into holes (§ 1926.501(b)(4)(i)).

Final paragraph (b)(3)(ii) requires that employers ensure workers are protected from tripping into or stepping into or through any hole that is less than four feet above a lower level by covers or guardrail systems. The final rule differs from the proposal in two ways. First, final paragraph (b)(3)(ii) clarifies that OSHA intended that the proposed requirement only applied to holes that are less than four feet above a lower level. Where a hole is four feet or more above a lower level, the requirements in final paragraph (b)(3)(i) apply and ensure that workers do not step or trip into the hole or fall into it. Second, final paragraph (b)(3)(ii) provides greater control flexibility than the proposal and the construction fall protection standard because it adds guardrail systems as an alternative option employers may use to protect workers from tripping or stepping into holes. Proposed paragraph (b)(3)(ii) and the construction standard (§ 1926.501(b)(4)(ii)) only permit employers to use covers to prevent stepping or tripping into holes.

Final paragraph (b)(3)(iii), like the existing standard (§ 1910.23(a)(1)) and the proposed rule (proposed paragraph (b)(14)(i)), requires that employers ensure workers are protected from falling into stairway floor holes by a fixed guardrail system erected on all exposed sides, except at the stairway entrance. The final rule also carries forward, with revisions, the existing and proposed exception for stairways when (1) used less than once a day and (2) traffic across the opening prevents the use of a fixed guardrail system (e.g., stairway floor hole located in store aisle). In that situation, employers may protect workers from falling using a hinged floor-hole cover that meets the criteria in § 1910.29 plus a removable guardrail system on all exposed sides except the stairway entrance. The exception in the final rule is consistent with ANSI/ASSE A1264.1–2007, *Safety Requirements for Workplace Walking/Working Surfaces and Their Access; Workplace, Floor, Wall and Roof Openings; Stairs and Guardrails Systems* (ANSI/ASSE A1264.1–2007).

OSHA also clarifies the “infrequently used” language in the existing exception by incorporating the language in a note in the proposed rule stating that “infrequently used” means using the stairways “on less than a daily basis.” The exception in the final rule also clarifies the language in the existing and proposed rules requiring that the hinged floor-hole cover be of “standard strength and construction” by specifying that the cover must meet the criteria in final § 1910.29, specifically § 1910.29(e). OSHA believes the language in the final rule will make the rule easier for employers to understand and follow. For example, requiring that the hinged floor-hole cover meet the requirements in § 1910.29 ensures that they will support, without failure, at least twice the maximum intended load that may be imposed on the cover (final § 1910.29(e)(1)). This is important because a hinged floor-hole cover, like all covers, need an adequate margin of safety to ensure they are capable of supporting intended loads, and to account for the possibility of unforeseen traffic across the cover.

In addressing stairways used less than once a day, OSHA requested information and comment in the proposed rule on using automatically rising railings that come into position when a load-bearing hinged floor-hole cover opens (75 FR 28892). Explanatory paragraph E3.1 in ANSI/ASSE A1264.1–2007 states that the removable guardrail system required for infrequently used stairways should be “hinged or otherwise mounted so as to come into position automatically with the opening of the [hinged floor-hole] cover.” Ameren commented, “As long as the automatic rising railings are an option and not the only method of protection this provision would be feasible” (Ex. 189). OSHA did not receive any comments supporting making automatically rising guardrails mandatory, and the final rule does not include such a requirement.

Final paragraph (b)(3)(iv), similar to the existing (§ 1910.23(a)) and proposed (proposed paragraph (b)(14)(ii)) rules, requires that employers ensure they protect workers from falling into ladderway floor holes or ladderway platform holes by providing a guardrail system and toeboards on all exposed sides, except at the hole entrance. In addition, the final rule requires that employers protect the access opening in the guardrail system by using a “self-closing” gate or an offset so workers cannot walk or step into the hole.

Final paragraph (b)(3)(iv) substitutes “self-closing” gate for “swinging” gate language in the existing and proposed

rules. The purpose of these gates, when open, is to provide a means of access to ladderway floor holes and, when closed, to provide guardrail protection that meets all the criteria in final paragraph (b). The term “swinging” gate, as used in the existing and proposed rules, refers to gates that automatically swing back into a closed position when the opening is not being used for access to prevent workers from falling into the ladderway hole. These are sometimes called “safety gates” (Ex. 68). If gates do not swing automatically into a closed position, they do not provide the required guardrail protection.

OSHA is aware that, in addition to swinging gates, there are automatically closing sliding gates that are currently manufactured, readily available, and in use to protect workers from falling into ladderway floor and platform holes. OSHA believes these sliding gates provide protection that is as effective as the protection swinging gates provide. Therefore, to give employers the flexibility to use the type of automatically closing gate that works best for them, OSHA uses the term “self-closing” gates in final paragraph (b)(3)(iv).

OSHA received one comment on the proposed requirement. Edison Electric Institute (EEI) recommended that OSHA allow employers to use double chains “around holes used as points of access (such as ladderways)” (Ex. 207). “Many industrial facilities use double chains instead of swinging gates or guardrails at the top of fixed ladders,” EEI said. “These have been effective for a number of decades” (Ex. 207). EEI also pointed out that the 1990 proposed rule would have allowed the use of chains, in addition to swinging gates and offsets, at the access openings in the guardrail systems.⁵⁰

OSHA has not adopted EEI’s recommendation. In the preamble to the 2010 proposed rule, OSHA said the new proposed rule replaces the 1990 proposal (75 FR 28863). Unlike the 1990 proposal, proposed paragraph (b)(14)(ii)

⁵⁰ See also Letter to Mr. Stephen Hazelton (5/23/2005) that states:

[T]he [1990] proposed paragraph at 1910.28(b)(6) permits the use of movable guardrail sections such as gates, chains, and other means, which, when open, provide a means of access and, when closed, provide the guardrail protection that meets the proposed paragraphs 1910.28(b)(1) through (b)(5). An employer’s compliance with the proposed rule, in lieu of compliance with an existing rule [1910.23(a)(2)], is considered as a de minimis violation.

This letter available on OSHA’s website at:

https://www.osha.gov/pls/oshaweb/owadisp.show_document?p_table=INTERPRETATION&p_id=25100.

did not permit employers to use double chains in place of self-closing gates or offsets. As mentioned, OSHA believes that chains less protective than self-closing gates or off sets. Self-closing gates and offsets are passive fall protection methods that automatically restore guardrail protection as soon as the worker passes through the opening or offset area. Neither method requires the worker to take any action to restore that protection. However, if employers provide double chains at entrances to ladderway floor or platform holes, their employees would have to remove the chains and reattach them once they pass through the opening. If workers forget or fail to reattach the chains, they and others in the area could fall through the hole. Workers also are at increased risk of falling through the hole once they enter the area inside the guardrails to climb down the ladder because they have to turn around and away from the hole to reattach the chains and risk falling backward into the hole. If workers avoid this risk by not reattaching the chains, it exposes other workers to the risk of a fall when they approach the opening in the guardrail system. OSHA believes that double chains do not fully protect workers from falls at hole entrances, and therefore, is adopting the existing and proposed requirements that entrances to ladderway floor and platform holes have a self-closing gate or be offset to prevent workers from falling.

Final paragraph (b)(3)(v), like proposed paragraph (b)(14)(iii), requires that employers ensure workers are protected from falling through hatchway and chute-floor holes by one of the following:

- A hinged floor-hole cover and a fixed guardrail system that leaves only one exposed side.⁵¹ When the hole is not in use, the employer must ensure the cover is closed or a removable guardrail system provided on all exposed sides (final paragraph (b)(3)(v)(A));
- A removable guardrail system and toeboards on not more than two sides of the hole and a fixed guardrail system on all other exposed sides. The employer must ensure the removable guardrail system remains in place when the hole is not in use (final paragraph (b)(3)(v)(B)); or
- A guardrail system or travel restraint system when the work operation necessitates passing material

through a hatchway or chute floor hole (final paragraph (b)(3)(v)(C)).

With one exception (final paragraph (b)(3)(v)(C)), the final rule generally is consistent with existing § 1910.23(a)(3) and A1264.1–2007 (Section 3.1). Final paragraph (b)(3)(v)(C) adds a requirement that employers provide a guardrail system or travel restraint system when workers need to pass materials through a hatchway or chute-floor hole. The existing and ANSI rules only state that “protection shall be provided to prevent a person from falling through the opening,” but do not specify what protection is needed. OSHA believes the final rule is more protective and clearer than these rules because it specifies how employers must protect workers. OSHA adopts final paragraph (b)(3) as discussed.

Dockboards. Final paragraph (b)(4) adds fall protection requirements to protect workers on dockboards. The final rule defines a “dockboard” as a portable or fixed device for spanning a gap or compensating for the elevation difference between a loading platform and a transport vehicle. Dockboards include, but are not limited to bridge plates, dock plates, and dock levelers. (final § 1910.21(b)).

Final paragraph (b)(4)(i), like the proposal, requires that employers ensure each worker on a dockboard is protected from falling four feet or more to a lower level by a guardrail system or handrails. The final rule limits the fall protection options that employers may use. OSHA believes guardrails and handrails will provide adequate protection for workers. In addition, employers can use them on dockboards while other options may not work. For example, it may not be possible to install anchorages on dockboards that would support the use of personal fall arrest systems.

OSHA notes that in some situations there may be insufficient space between the dock and the transport vehicle for a worker to fall and, therefore, no fall hazard would exist. In that situation, final paragraph (b)(4)(i) would not apply.

Final paragraph (b)(4)(ii), like the proposal, includes an exception specifying that employers do not have to provide a guardrail system or handrails when:

- Using the dockboard solely for materials-handling operations using motorized equipment (final paragraph (b)(4)(ii)(A));
- Workers engaged in motorized material-handling operations are not exposed to fall hazards greater than 10 feet (final paragraph (b)(4)(ii)(B)); and

- Employers train those workers in accordance with § 1910.30 (final paragraph (b)(4)(ii)(C)).

Final paragraph (b)(4)(ii)(C) does not include the proposed language identifying the subjects that training must address. The requirements in final § 1910.30 cover all of the topics OSHA proposed, thus, OSHA does not believe it is necessary to repeat them in this provision.

OSHA believes the exception in final paragraph (b)(4)(ii) is appropriate. Employers often use motorized equipment to move large and heavy material across dockboards. However, such equipment may not fit on a dockboard that has guardrails or handrails. Preventing workers from using motorized equipment to move the material may expose them to other hazards, such as risk of injury associated with lifting and carrying heavy materials. OSHA did not receive any comments on the proposed dockboard requirements, and finalizes the provisions as discussed.

Runways and similar walkways. Final paragraph (b)(5) specifies the fall protection systems that employers must provide to protect workers from falling off runways and similar walkways. The proposed and final rules define a “runway” as an elevated walking-working surface (§ 1910.21(b)). For purposes of the final rule, runways include catwalks, foot walks along shafting, and elevated walkways between buildings.

Final paragraph (b)(5)(i), like the proposed rule, retains the existing requirement (§ 1910.23(c)(2)) that employers must protect workers on runways or similar walkways from falling four feet or more to a lower level by a guardrail system. The final rule generally is consistent with the construction fall protection standard (§ 1926.501(b)(6)). Like dockboards, the final rule limits the fall protection options employers may use. OSHA believes that guardrails will provide adequate protection from falls, and that other options may not work on runways. For example, it may not be possible for employers to install anchorages and other components of personal fall protection systems that would protect workers from falling off runways while still allowing them to walk on the runway.

Final paragraph (b)(5)(i) no longer includes the existing and proposed requirement that employers provide toeboards on both sides of runways if workers are likely to use tools, machine parts, or other objects on the runway. The primary purpose of requiring toeboards is to prevent objects from

⁵¹ OSHA used the term “permanently attached” guardrail system in the proposal. In the final rule, OSHA uses the term “fixed” guardrail systems, which OSHA considers to be equivalent to, but clearer than, the proposed term.

falling onto workers on a lower level. As mentioned earlier, OSHA consolidated all requirements addressing falling object hazards in final paragraph (c), and, therefore, does not repeat them here.

Final paragraph (b)(5)(ii), which is similar to the proposed rule, addresses runways used exclusively for special purposes, such as filling tank cars. The final paragraph requires that when the employer can demonstrate that it is not feasible to have guardrails on both sides of special purpose runways, the employer may omit the guardrail on one side, provided the employer:

- Ensures that the runway is at least 18 inches wide (final paragraph (b)(5)(ii)(A)); and
- Provides each worker with, and ensures that each worker uses, a personal fall arrest system or travel restraint system (final paragraph (b)(5)(ii)(B)).

The final rule clarifies two points in the proposed rule. First, the final rule clarifies that guardrails may be omitted from a special purpose runway only when the employer can demonstrate that it is not feasible to have guardrails on both sides of the runway. Feasibility is the standard test of whether employer action is possible, and OSHA believes employers are familiar with, and understand, it.

Second, final paragraph (b)(5)(ii)(B) clarifies the language in the proposed rule requiring that employers ensure “the proper use of personal fall arrest systems or travel restraint systems.” This provision means that employers may omit a guardrail on one side of a special purpose runway only when the employer both provides and ensures that each worker properly uses a personal fall arrest system or travel restraint system.

OSHA notes that the final rule provides greater protection for workers than both the existing rule (§ 1910.23(c)(2)) and A1264.1–2007 (Section 5.2). Although these standards specify that employers may omit a guardrail on one side of a special use runway only if they use a runway that is at least 18 inches wide (consistent with final paragraph (b)(5)(ii)(A)), the standards do not require that employers provide, and ensure that workers use, personal fall arrest or travel restraint systems while on those runways.

OSHA received no comments on the proposed runway requirements, and adopts them with the revisions discussed above.

Dangerous equipment. Final paragraph (b)(6) addresses the hazards associated with working above dangerous equipment. Final

§ 1910.21(b) adopts the definition of “dangerous equipment” in the construction fall protection standard (§ 1926.500(b)). The definition also specifies that such equipment includes vats, tanks, electrical equipment, machinery, machinery with protruding parts, or similar units that, because of their function or form, may harm a worker who falls into or onto the equipment. The existing rule in § 1910.23(c)(3) also provides examples of equipment OSHA considers to be dangerous, including pickling or galvanizing tanks and degreasing units. The definition of dangerous equipment in this final rule includes similar equipment. OSHA added a definition of dangerous equipment to the final rule in response to Northrup Grumman Shipbuilding’s (NGS) recommendation that OSHA define the term so that employers understand what equipment the final rule covers (Ex. 180).

This final rule, like the proposed rule, includes requirements for protecting workers who are working less than four feet above dangerous equipment. OSHA believes it is necessary to protect workers from falling onto or into dangerous equipment regardless of how far above the equipment they are working. Falling less than four feet into or onto equipment that has sharp, protruding, or moving parts could kill or seriously injure a worker.

When workers are less than four feet above dangerous equipment, final paragraph (b)(6)(i), like the proposed rule, requires that employers protect workers from falling into or onto the dangerous equipment using a guardrail system or a travel restraint system, unless the equipment is covered or guarded to eliminate the hazard. The existing rule in § 1910.23(c)(3) requires that, regardless of height, employers must protect workers who are working above dangerous equipment using guardrails and toeboards. The construction fall protection standard contains a provision requiring guardrails or equipment guards when workers are working less than six feet above dangerous equipment (§ 1926.501(b)(8)).

OSHA believes final paragraph (b)(6)(i), which allows employers to protect their workers by providing either guardrails or travel restraint systems, but does not require toeboards, provides greater control flexibility than the existing rule without compromising worker safety. OSHA believes that either guardrails or travel restraint systems provide sufficient protection for workers above dangerous equipment. Therefore, OSHA does not believe that toeboards, which primarily protect workers from

falling objects from higher levels, are necessary. Accordingly, OSHA deleted the existing toeboard requirement, but notes that final paragraph (c)(1) of this section requires that employers provide toeboards to protect workers from objects falling from higher levels and hitting them.

OSHA notes that the final rule does not permit employers to use safety nets or personal fall arrest systems when workers are less than four feet above dangerous equipment. At these heights, safety nets and personal fall arrest systems may not be safe to use because there may not be sufficient stopping distance to prevent a falling worker from making contact with the dangerous equipment.

Final paragraph (b)(6)(i), like the proposal, does not require employers to use guardrails or travel restraint systems if the employer covers or guards dangerous equipment and the worker is less than four feet above the equipment. OSHA believes that covering or guarding dangerous equipment that is less than four feet below workers adequately eliminates the hazard.

When workers are four feet or more above dangerous equipment, final paragraph (b)(6)(ii), like the proposed rule, requires that employers protect workers from falling by providing:

- Guardrail systems (final paragraph (b)(6)(ii)(A));
- Safety net systems (final paragraph (b)(6)(ii)(B));
- Travel restraint systems (final paragraph (b)(6)(ii)(C)); or
- Personal fall arrest systems (final paragraph (b)(6)(ii)(D)).

Final paragraph (b)(6)(ii) provides more control flexibility for employers than the existing rule, which requires that employers protect workers from falling onto or into dangerous equipment by providing a guardrail system. OSHA believes that allowing employers to use a range of fall protection options ensures that employers will be able to select the fall protection option that best fits the particular workplace situation and conditions.

OSHA received two comments on the proposed provision. Verallia recommended that OSHA delete the requirement because they said the proposal was “too subjective and vague” and “could be interpreted differently” (Ex. 171). However, Verallia did not provide examples or further explain its recommendation. As mentioned earlier, this final rule adds a definition of dangerous equipment, which also includes examples of specific equipment OSHA considers to be dangerous. The final rule specifically

and clearly identifies what constitutes dangerous equipment, what protections employers must provide at specific heights, and when and at what height employers can protect workers from falling using fall protection options other than guardrails or travel restraint systems. Moreover, OSHA believes the examples of equipment OSHA defines as being dangerous specifically clarifies, in objective terms, under what conditions employers must comply with the final rule and, therefore, reduces the possibility of conflicting interpretations.

The second commenter, NGS, said the proposed rule was not as protective as the existing rule and would not provide an equivalent level of protection from “open pits, vats, etc.” as existing § 1910.22(c) (Ex. 180). NGS recommended that “standard guardrails be required around open tanks” and “vats that contain hazardous substances that pose an immediate threat to life” (Ex. 180). OSHA does not believe including NGS’s recommendations are necessary in this final rule. First, although final paragraph (b)(6) does not retain existing § 1910.22(c) as a separate provision, OSHA incorporated into the final definition of dangerous equipment all of the equipment § 1910.22(c) covers, including the equipment NGS mentioned. The final rule does not leave any dangerous equipment unaddressed, and, therefore, the Agency believes the final rule provides protection equivalent to that in existing § 1910.22(c).

Second, the final rule allows employers to use controls that provide equivalent or greater protection than the controls specified in existing § 1910.22(c). OSHA believes that giving employers flexibility in choosing what protection to use will enable them to select the measure that works best, and is the most effective, in the particular work situation. Third, the final rule recognizes that it may not be possible to use guardrails in a particular situation and provides employers with alternatives that will protect their workers in those cases.

Fourth, where dangerous equipment is not covered or guarded, final paragraph (b)(6)(i) requires that employers use guardrails or travel restraint systems to protect workers from falling onto the dangerous equipment, when the height of the fall is less than four feet. OSHA notes that employers are free to use guardrails when an employee works at any height above dangerous equipment.

Openings. Final paragraph (b)(7), similar to the proposed rule, requires that employers protect workers from falling through openings. Final § 1910.21(b), like both the proposed and

construction (§ 1926.500(b)) rules, defines an “opening” as a gap or open space in a wall, partition, vertical walking-working surface, or similar surface that is at least 30 inches high and at least 18 inches wide through which a worker can fall to a lower level.

The final rule requires that employers protect workers on walking-working surfaces near openings (including openings with a chute attached) if the inside bottom edge of the opening is less than 39 inches above the walking-working surface and the outside bottom edge of the opening is four feet or more above a lower level. The employer must protect workers from falling through those openings by providing:

- Guardrail systems (final paragraph (b)(7)(i));
- Safety net systems (final paragraph (b)(7)(ii));
- Travel restraint systems (final paragraph (b)(7)(iii)); or
- Personal fall arrest systems (final paragraph (b)(7)(iv)).

The final rule, unlike the proposal (proposed paragraph (b)(7)(ii)), does not allow employers to use designated areas instead of providing conventional fall protection to protect workers from falling through openings. As discussed above, the final rule limits the use of designated areas to the limited and specific situation of work on low-slope roofs. Deleting the option of designated areas from final paragraph (b)(7) makes the provision consistent with the construction standard, which also does not allow the use of designated areas to protect workers from falling through openings (§ 1926.501(b)(14)).

The final rule simplifies, updates, and increases the control flexibility of the existing rule. For example, the final rule establishes one set of requirements that apply to all openings, while the existing rule, in § 1910.23(b), contains different provisions for different types of wall openings (e.g., chute-wall, window-wall, and temporary wall openings). The final rule also incorporates new fall protection technology (e.g., personal fall arrest systems, travel restraint systems, safety net systems) in place of some of the measures listed in the existing rule (e.g., rail, roller, picket fence, half door, standard slats, standard grill work). OSHA believes that allowing employers to use new technology will enhance worker protection.

Finally, in several ways the final rule provides more flexibility than the existing rule. First, the final rule only requires employers to provide fall protection when the inside bottom edge of the opening is less than 39 inches above the floor or other type of walking-working surface, while the existing rule,

with one exception, generally requires employers to protect wall openings regardless of the height of the bottom inside edge of the opening.⁵² OSHA does not believe that it is necessary to provide fall protection when the bottom inside edge of openings are 39 inches or higher than the walking-working surface on which the worker is standing; in such cases, OSHA believes the wall or partition itself usually provides adequate protection against falling through the opening. Second, the final rule allows employers to use a wider range of fall protection options than the existing rule to protect workers near wall openings. OSHA believes the increased flexibility will ensure that workers have the most effective protection because employers will be able to select the fall protection option they determine works best in the particular situation. Finally, paragraph (b)(7) of the final rule, unlike the existing rule in § 1910.23(b)(1) and (e)(10), does not require that employers install grab handles on each side of wall openings. OSHA believes that the fall protection options specified by final paragraph (b)(7) provide adequate protection from falls through wall openings, and therefore, grab handles are not necessary.

As discussed in the preamble to the proposed rule, when work operations require that workers reach through wall openings to facilitate hoisting materials, OSHA considers the opening to be a “hoist area” covered by final paragraph (b)(2), and not a wall opening. OSHA believes this distinction is important. Final paragraph (b)(7) allows employers to use guardrail, personal fall arrest, travel restraint, or safety net systems to protect workers from falling through wall openings. However, it is not always possible to use a safety net system to protect workers from falling when they are hoisting materials through an opening because a safety net system may interfere with materials being hoisted or may not provide a sufficient stopping distance to prevent a falling worker from making contact with the lower level. Accordingly, final paragraph (b)(2) specifies that employers must protect workers using only a guardrail, personal fall arrest, or travel restraint systems. Moreover, when workers need to lean out or over the edge of the hoist area, final paragraph (b)(2) requires that employers protect workers with personal fall arrest

⁵² OSHA notes the existing provision (§ 1910.23(b)(3)) for window wall openings at stair landings, floors, platforms, or balconies did not require fall protection if the bottom edge of the opening is three feet or more above the landing, floor, platform, or balcony.

systems. Final paragraph (b)(7) does not contain the protective limitations specified by final paragraph (b)(2). OSHA did not receive any comments on proposed paragraph (b)(7), and adopts it as discussed.

Repair, service and assembly pits (pits) less than 10 feet deep. Final paragraph (b)(8), like the proposed rule, adds a new provision addressing fall hazards associated with repair, service, and assembly pits that are less than 10 feet deep. Employers use these pits primarily to provide access to the underside of vehicles to perform work, such as vehicle maintenance. Typically, a worker drives a vehicle over the pit and uses stairs to get into the pit. The final rule specifies that employers do not have to provide fall protection systems for service, repair, or assembly pits that are less than 10 feet deep, provided the employer:

- Limits access within six feet of the pit edge to authorized workers trained in accordance with final § 1910.30 (final paragraph (b)(8)(i));
- Applies floor markings or warning lines and stanchions, or a combination thereof, at least six feet from the pit edge. Floor markings must be a color that contrasts with the surrounding area and warning lines and stanchions must be capable of resisting, without tipping over, a force of at least 16 pounds that is applied horizontally against the stanchion at a height of 30 inches (final paragraph (b)(8)(ii)); and
- Posts readily visible caution signs that state “Caution—Open Pit” and meet the requirements of § 1910.145, Specifications for Accident Prevention Signs (final paragraph (b)(8)(iii)).

Final paragraph (b)(8) only applies to service, repair, and assembly pits that are less than 10 feet deep. For deeper pits, employers must provide a conventional fall protection system specified in final paragraph (b)(1), Unprotected sides and edges.

Neither the existing nor construction fall protection rules contain a similar provision on service, repair, and assembly pits. Historically, OSHA addressed these hazards through Section 5(a)(1) (General Duty Clause) of the OSH Act (29 U.S.C. 654).

The final rule recognizes that protecting workers from falling into service, repair, and assembly pits can present some unique issues. For example, for vehicle service and repair pits, the fall hazard is present only when a vehicle is not over the pit. Driving a vehicle over the pit normally eliminates the fall hazard. In addition, conventional fall protection systems may not work at service, repair, and assembly pits. For instance, using

guardrails can interfere with driving vehicles over or away from a pit, and personal fall arrest and travel restraint systems may prevent workers from reaching the area where they need to perform work. Finally, it is OSHA’s understanding that workers are unlikely to be near service, repair, and assembly pits when they are not working on vehicles.

OSHA believes the final rule strikes an appropriate balance between protecting workers and ensuring that they can repair, service, or assemble vehicles. The Agency believes that establishing well-marked areas (that is, floor markings or warning lines and stanchions, or both), along with posting caution signs, will be effective in warning authorized workers that they are about to enter a hazardous area, and other workers that they need to keep out of the area. In addition, limiting access within six feet of pits to those workers who the employer specifically assigns or allows to be in the area, and who, as a result of training, recognize the applicable fall hazards, will keep worker exposure to these hazards to a minimum.

OSHA received comments on the proposed provision from the American Trucking Associations, Inc. (ATA) and the American Truck Dealers Division of the National Automobile Dealers Association (NADA). Both organizations supported the proposed rule (Exs. 181; 187). NADA said, “These proposed requirements should serve to adequately address the potential for fall hazards related to motor vehicle service pits” (Ex. 181).

OSHA added a sentence to the final rule addressing the situation where two or more pits are in a common area and are not more than 15 feet apart. It specifies that OSHA employers may comply with final paragraph (b)(8)(ii) if they place contrasting floor markings at least six feet from the pit edge around the entire area of the pits. OSHA added the sentence to respond to a comment from ATA, which stated:

OSHA should include a provision stating that when two or more pits are in a common area, a perimeter marking and the posting of appropriate warnings around the entire area will meet the requirements of this section. In addition, when the distance from a building entrance to the pit is less than 6 feet, a floor marking and warning sign at the entrance will satisfy the requirements (Ex. 187).

ATA also noted, “In some large motor carrier facilities, there may be two or more adjacent pits in one area of the shop,” that “[t]he distance between pits can vary from 12 to 15 feet,” and that “the distance from the doorway to the closest portion of the pit . . . is less

than six feet” (Ex. 187). OSHA believes the added sentence in the final rule addresses ATA’s concerns and finalizes the provision as discussed.

Fixed ladders (that extend more than 24 feet above a lower level). Final paragraph (b)(9) establishes fall protection requirements for fixed ladders that extend more than 24 feet above a lower level. Final § 1910.21(b), like the proposed rule, defines “fixed ladder” as a ladder with rails or individual rungs that is permanently attached to a structure, building, or equipment. Fixed ladders include individual rung ladders, but not ship stairs, step bolts, or manhole steps.

Final paragraph (b)(9), like the proposal, only requires that employers provide fall protection to those fixed ladders that extend more than 24 feet above a lower level. The existing rule (§ 1910.27(d)(1)(ii)) requires that fixed ladders more than 20 feet above a lower level be equipped with cages or wells. Changing the fall protection trigger height to 24 feet makes the final rule consistent with ANSI/ASC A14.3–2008 and OSHA’s construction ladder standard (§ 1926.1053(a)(18) and (19)), which is one of the Agency’s goals in this rulemaking. This change allows workers who perform both general industry and construction activities to use fixed ladders with the same fall protection trigger height.

Siebe North, Inc., a manufacturer of ladder safety systems and personal fall arrest systems, supported the proposed change in the fall protection trigger height for fixed ladders (Ex. OSHA–S041–2006–0666–0198). CSG and ISEA, on the other hand, argued that OSHA should require fall protection on fixed ladders from the ground up (Exs. 185; 198). As discussed above, limiting fall protection to fixed ladders that extend more than 24 feet above a lower level makes the final rule consistent with both OSHA’s construction rule and the long-standing ANSI standard (A14.3). In any event, OSHA does not believe the change from the existing rule will affect worker safety substantially because fixed ladders that extend more than 24 feet must have fall protection systems that protect workers from the ground up even if workers climb the ladder less than 24 feet above the lower level.

In final paragraph (b)(9)(i), OSHA revises the existing fall protection requirements for fixed ladders. The final rule requires that employers equip fixed ladders with ladder safety systems or personal fall arrest systems to protect workers from falling to a lower level, which could result in death or serious injury. Final paragraph (b)(9)(i) establishes a new framework to protect

workers from fall hazards on fixed ladders that allows employers to gradually, over 20 years, phases in ladder safety systems/personal fall arrest systems and phase out the use of cages and wells as a means of fall protection. After this 20-year period ends, the final rule requires that employers must ensure all fixed ladders are equipped with either ladder safety or personal fall arrest systems to protect workers from fall hazards. The final rule establishes the following phase-in/phase-out schedule:

- For existing fixed ladders (that is, for ladders erected before November 19, 2018)—employers have up to 20 years to install ladder safety or personal fall arrest systems (final paragraph (b)(9)(i)(A));
- For new fixed ladders (that is, for new ladders erected on or after November 19, 2018)—the employer must equip the new ladder with a ladder safety or personal fall arrest system (final paragraph (b)(9)(i)(B));
- For ladder repairs and replacements—when an employer replaces any portion of a fixed ladder the replacement must be equipped with a ladder safety or personal fall arrest system (final paragraph (b)(9)(i)(C)); and
- The final deadline for all fixed ladders—on and after November 18, 2036 all fixed ladders must be equipped with a ladder safety or personal fall arrest system (final paragraph (b)(9)(i)(D)). (See further discussion of phase-out schedule below.)

The gradual phasing out of cages and wells means that employers may continue to use existing fixed ladders during the 20-year phase-out period, even if the existing fixed ladders are equipped only with cages and wells. However, during the 20-year phase out period, when employers install new fixed ladders or replace a portion of a section on an existing fixed ladder, final paragraphs (b)(9)(i)(B) and (C) require them, respectively, to install a new fixed ladder equipped with a ladder safety or personal fall arrest system (when replacing the entire ladder) or equip the replacement section (e.g., a ladder with multiple, offset sections) with a ladder safety system or personal fall arrest system (when replacing a portion of an existing fixed ladder). At the end of 20 years, final paragraph (b)(9)(i)(D) specifies that all fixed ladders must be equipped with ladder safety or personal fall arrest systems. (OSHA notes that after the 20-year phase out period ends employers may still have or equip fixed ladders with cages and wells, but OSHA will not consider them to be a means of fall protection.)

The proposed rule would have allowed employers to use cages, wells, ladder safety systems, or personal fall arrest systems when the length of a climb is less than 24 feet regardless of the height of the ladder (proposed § 1910.28(b)(9)(i)). When the total length of a climb on a fixed ladder is at least 24 feet, the proposed rule would have allowed employers to equip the fixed ladder with a ladder safety system, personal fall arrest system, cage or well (proposed § 1910.28(b)(9)(ii)). OSHA is phasing in the requirement to equip fixed ladder with ladder safety systems/personal fall arrest systems and phasing out the use of cages and wells as a means of fall protection because there is wide recognition in general industry that cages and wells neither prevent workers from falling off ladders nor protect them from injury when a fall occurs (e.g., Exs. OSHA–S041–2006–0666–0198; 113; 155; 185; 198; 329 (1/21/2011), pgs. 18–19, 259). In general, stakeholders said cages and wells simply “contain employees in the event of a fall and direct them to a lower landing” rather than preventing them from hitting a lower level (Ex. 113; see also Exs. OSHA–S041–2006–0666–0198; 155; 185; 198; 329 (1/21/2011), pgs. 18–19, 259)). In addition, they also said fixed ladder cages and wells may result in severe injury or fatality and increase the severity of fall injuries (Ex. 113; 185; 198; OSHA–S041–2006–0666–0198). Therefore, they said OSHA should require that fixed ladders be equipped with ladder safety systems or personal fall arrest systems (Exs. OSHA–S041–2006–0666–0198; OSHA–S041–2006–0666–0354; 113; 155; 185; 198; 329 (1/21/2011), pgs. 18–19, 259).

As far back as 1990, when OSHA first raised the question about the effectiveness of cages and wells as a means of fall protection on fixed ladders, Siebe North, Inc., a manufacturer of ladder safety and personal fall protection systems, said OSHA should require that fixed ladders be equipped with ladder safety systems or personal fall arrest systems:

Except to the extent that a cage or well will change the trajectory of a fall so that the victim falls directly to the base of the ladder, we are unaware of any empirical or other data which suggests that a cage or well will otherwise result in a fall which is not a free fall—or, more importantly, a fall likely to result in less severe injury than would be caused by a free fall of the same distance. (Indeed, most falls of any significant distance in cages, and probably in wells as well, are likely to add to the victim’s trauma due to impacts with the cage or well during the course of the fall.)

* * * * *

As already noted, except to the extent that it directs the victim’s falling body to the base of the ladder, a cage or well provides no protection for the falling climber. On the other hand, where a ladder safety device is used, a climber’s fall is stopped in 2 feet or less, with no trauma from this short fall. When a fall occurs, a ladder safety device alone will *both save a life and prevent injury*, no matter where in the climb the fall begins. On the other hand, a cage or well will do neither. If the ladder is equipped with only a cage or well, whether a falling climber dies or merely lives with severe injury depends entirely on the length of the fall since the cage or well will have no protective effect (Ex. OSHA–S041–2006–0666–0198) (emphasis in original).

In response to the 2010 proposed rule, a number of commenters also agreed that employers need to equip fixed ladders with ladder safety systems/personal fall arrest systems because cages and wells are not effective fall protection measures (Exs. 113; 185; 198; 329 (1/18/2011), p. 96; 329 (1/21/2011), p. 259). For example, CSG said:

[C]ages should not be used as an individual method of fall protection, but only in conjunction with a personal fall arrest/cable-and-rail system or a twin-leg lanyard. CSG recognizes that a cage system allows a measure of security. However, if a person does fall in a cage, OSHA is correct that the cage will direct the person to the ground, likely resulting in a severe injury or fatality (Ex. 198).

ISEA agreed with CSG (Ex. 185). The Oregon Department of Transportation (DOT) added:

Ladder cages are an old technology used for decades before ladder safety systems were ever developed. . . . [C]ages and wells are designed to “. . . contain employees in the event of a fall and direct them to a lower landing.” Cages provide little fall protection and no fall prevention. They do give a sense to the climber of being contained, and do provide a surface to rest against for a winded climber, but will not prevent a fall. Falls in cages can be very gruesome with the faller entangling themselves in the cage as they fall, sometimes tearing off body parts (Ex. 113).

Similarly, Ellis testified that OSHA should prohibit the use of cages and wells for fall protection because he said they are ineffective:

[T]his may be the time to withdraw cages since they are ineffective. I refer to the [Health and Safety Executive] Report on their website relating to cages and the testing that’s being done to show that they’re incapable of stopping falls. It may not be OSHA’s best move to keep citing a device that fails to work which most people would admit that you’re not get stopped in a fall. The best that happens in a fall inside a cage is to be a—have a feeling of being contained. . . . (Ex. 329 (1/21/2011), p. 259)).

The Health and Safety Executive (HSE) report Ellis cited was

“Preliminary investigation into the fall-arresting effectiveness of ladder safety hoops” (Research Report 258–2004).⁵³ The Executive Summary states:

After studying the information from the references, the survey, from the accident database and the results from testing, it seems clear that caged ladders cannot provide positive fall-arrest capability, especially in the case of the three-upright design which was tested as part of this research. There is every possibility of a fall down the cage to the ground or other platform.

There would appear, or so it seems, a possibility to stop the fall of a worker in certain circumstances, but this depends upon the attitude of the worker both before the fall and during the fall, and whether or not the worker manages to catch part of his or her body in one of the cage apertures, or manages to trap themselves in the cage some other way. In any event, it is a chance occurrence, and the opinion is that even if the worker could be caught by the cage, it could lead to significant if not fatal injury.

The accidents reviewed indicate that workers fall down cages to the next level and are rarely caught. Injuries have been reported. Even if a fall is halted by limb entanglement within a cage, rescue would be extremely difficult process to carry out successfully (Ex. 392).

OSHA believes there is substantial evidence in the rulemaking record to support eliminating the use of cages and wells as a means of fall protection on fixed ladders. Therefore, for the reasons discussed above, OSHA is phasing out their use and requiring that employers equip fixed ladders with ladder safety systems or personal fall arrest systems according to the schedule established in final paragraph (b)(9)(i).

OSHA believes that gradually phasing out the use of cages and wells as a means of fall protection over 20 years and requiring employers to provide ladder safety systems/personal fall arrest systems prospectively (that is, when installing new fixed ladders or replacing a portion of an existing fixed ladder section) is a safe, cost-effective way to increase worker protection beyond the existing and proposed rules, and will not pose difficulties or undue burdens for employers. For example, ladder safety and personal fall arrest systems generally are less costly and easier to install on fixed ladders than cages and wells. OSHA believes that providing 20 years to phase out cages and wells gives employers ample time to plan and carry out this transition as part of their normal business and replacement cycles, instead of retrofitting fixed ladders. According to the FEA, the useful life of a large

majority of fixed ladders will be exhausted within 20 years.

Several stakeholders specifically recommended that OSHA prospectively require new fixed ladder be equipped with ladder safety systems/personal fall arrest systems (Exs. OSHA–S041–2006–0666–0198; 113; 329 (1/21/2011), p. 18–19). For example, Siebe North supported installing ladder safety systems/personal fall arrest systems “in the design stage” because “ladder safety devices can be engineered into and installed as part of the original ladder installation without any extra hazardous exposure to the installation workers,” adding that “well or cage installations hazards will always be significantly greater than the installation hazards for ladder safety devices” (Ex. OSHA–S041–2006–0666–0198). The American Wind Energy Association said:

Technology in fall protection has developed to the point where suitable solutions exist for the protection of climbers for fixed ladders. At a minimum, new installation of fixed ladders, that meet the trigger heights and length listed, should include falling-object for workers regardless of the industry. The wind industry is an example of a new industry that has embrace ladder-climbing systems across-the-board (Ex. 329 (1/21/2011), pgs. 18–19).

Siebe North also indicated that requiring employers to install ladder safety systems/personal fall arrest systems instead of cages/wells was cost effective, “For a 50-foot climb, a ladder safety device would cost about \$500 installed, but a case or well would cost in excess of \$1,500” (Ex. OSHA–S041–2006–0666–0198). Clear Channel Outdoor indicated that equipping billboard ladders with ladder safety systems/personal fall arrest systems would cost significantly less than installing cages and wells (Ex. 329 (1/18/2011), pgs. 134–35). Ameren Corporation recommended grandfathering in all existing ladders “due to the potential financial impact” (Ex. 189).

As mentioned, OSHA believes the prospective application of the requirement to equip fixed ladders with ladder safety systems or personal fall arrest systems will not pose financial hardship on employers. According to CSG, it is “common” for fixed ladders manufactured today to be equipped with ladder safety systems (Ex. 329 (1/18/2011), p. 104).

As mentioned, final paragraph (b)(9)(i) also establishes the cage and well phase-out dates for existing, new, replacement, and eventually all fixed ladders (*i.e.*, a final deadline when employers may no longer use cages and

wells as a means of fall protection on any fixed ladder):

*Existing fixed ladders.*⁵⁴ Final paragraph (b)(9)(i)(A) requires that employers ensure existing fixed ladders are equipped with at least one of the following four devices no later than November 19, 2018:

- A cage;
- A well;
- A ladder safety system; or
- A personal fall arrest system.

Although the existing rule requires that employers already must have installed cages or wells on fixed ladders, the record indicates some have not. Therefore, OSHA is giving employers two years to come into compliance with the existing rule (existing § 1910.27). Providing two years will ensure that employers have adequate time to order and install devices on fixed ladders and will reduce costs for employers who have ordered and not yet installed new fixed ladders equipped with cages or wells. Although the final rule is phasing out the use of cages and wells as a fall protection device, final paragraph (b)(9)(i) allows employers to continue to use existing fixed ladders that have a cage or well, but not ladder safety or personal fall arrest system, until:

- The fixed ladder, cage, or well, of portion of it is replaced (final paragraph (b)(9)(i)(C)); or
- November 18, 2036 (final paragraph (b)(9)(i)(D)), whichever comes first.

This means that employers may not have to install ladder safety or personal fall arrest systems on their existing fixed ladders for up to 20 years. However, OSHA believes that many employers already have installed ladder safety systems and personal fall arrest systems or will install those systems long before the 20-year deadline comes due.

Like final paragraph (b)(9)(i)(A), ANSI/ASC A14.3–2008 (Section 1.6.1) generally permits employers to use existing fixed ladders without change. The requirements of ANSI/ASC A14.3–2008 do not apply to existing fixed ladders, provided that the ladder was in compliance with a Federal, state, or national consensus standard at the time it was installed and there is documentation available to substantiate that (Section 1.6.1(1)), or a person competent in structural design determines that any differences in the existing ladder are such that its performance “will not substantially deviate from the requirements” of ANSI/ASC A14.3–2008 (Section 1.6.1(2)).

⁵⁴ For purposes of final paragraph (b)(9)(i)(A), the term “existing fixed ladder” includes any fixed ladder installed before November 19, 2018.

⁵³ The HSE Report is available at <http://www.hse.gov.uk/research/rrpdf/rr258.pdf>.

OSHA believes that most fixed ladders, except for some used in outdoor advertising, already have at least one of the four devices final paragraph (b)(9)(i)(A) requires and, therefore, will be able to continue using those ladders under the final rule. At a minimum, OSHA believes that most existing fixed ladders have cages or wells, which the existing rule (§ 1910.27(d)(1)(i)) has required since the Agency adopted it pursuant to section 6(a) of the OSH Act (29 U.S.C. 655(a)). Evidence discussed in the FEA also indicates that a significant percentage of employers already have ladder safety or personal fall arrest systems on existing fixed ladders.

For fixed ladders that do not have any fall protection, which appears to be the case in the outdoor advertising industry, final paragraph (b)(9)(i)(A) requires that employers install a cage, well, ladder safety system, or personal fall arrest system before November 19, 2018. OSHA believes that most of those employers will install ladder safety or personal fall arrest systems during that time. First, according to the FEA, those systems generally are less expensive than cages or wells. Second, even ANSI/ASC A14.3–2008 requires the use of ladder safety systems for some climbs (Sections 4.1.3, 4.1.4, 4.1.4.2). However, the Agency notes that employers also will be in compliance if they install cages or wells on existing fixed ladders during the first two years after the final rule is published.

One commenter, Ameren, said OSHA should make allowances for employers who have ordered fixed ladders but not yet received and installed them (Ex. 189). They said that it may take up to one year to receive a fixed ladder after placing the order. Final paragraph (b)(9)(i)(A) gives employers two years to install fall protection devices on their fixed ladders. As mentioned, OSHA considers ladders installed during this two-year period to be “existing fixed ladders,” which means employers may install any of the four devices specified in final paragraph (b)(9)(i)(A). Thus, employers will not have to change their orders if they purchased fixed ladders equipped with a well or cage. That said, OSHA believes many employers will change their orders to ladder safety or personal fall arrest systems which are less expensive than cages and wells and brings employers into compliance with final paragraph (b)(9)(i)(D) without having to make changes when the final phase-out deadline comes due.

New fixed ladders. Final paragraph (b)(9)(i)(B) requires that employers ensure new fixed ladders they install on and after November 19, 2018 are

equipped with a ladder safety system or personal fall arrest system. Requiring that new fixed ladders, rather than existing fixed ladders, be equipped with ladder safety or personal fall arrest systems makes the final rule primarily prospective. OSHA believes that employers should not have any difficulty complying with this approach.

OSHA believes virtually all new fixed ladders manufactured and installed today are available with ladder safety and personal fall arrest systems. Allowing employers two years to begin equipping new fixed ladders with ladder safety or personal fall arrest systems gives employers adequate time to identify companies that manufacture fixed ladders equipped with these systems. OSHA notes that the 2-year phase-in also gives ladder manufacturers time to ensure their ladder safety and personal fall arrest systems comply with the personal fall protection system criteria in the final rule (final § 1910.29).

OSHA points out that final paragraph (b)(9)(i)(B) does not prohibit employers from also installing cages and wells on new fixed ladders in addition to ladder safety or personal fall arrest systems. Cages and wells can provide a way for workers to rest while they are climbing and working on fixed ladders. However, OSHA stresses that employers may not use cages and wells instead of providing ladder safety and personal fall arrest systems. In addition, employers must ensure that the cages and wells are compatible with and do not interfere with the ladder safety or personal fall arrest systems. (See final paragraph (b)(9)(iv) for further discussion.)

Unlike final paragraph (b)(9)(i)(B), ANSI/ASC A14.3–2008 does not require that employers ensure new fixed ladders they install are equipped with ladder safety systems or personal fall arrest systems; but rather allows employers to install new ladders that only have cages or wells in some situations. For example, that standard allows employers to install new fixed ladders equipped with only cages where the length of any climb is less than 24 feet even though the top of the ladder is at a distance greater than 24 feet above a lower level (Section 4.1.2). Similarly, A14.3–2008 allows employers to install only cages or wells on new multiple-section fixed ladders that do not have a single length of climb exceeding 24 feet, provided each ladder section is offset horizontally from adjacent sections and there is a landing platform for safe access/egress (Section 4.1.4.1). That standard only requires employers to use ladder safety systems when a single length of climb exceeds 24 feet (Section

4.1.3) or the length of climb on multiple section ladders exceeds 50 feet (Section 4.1.4.2).

Final paragraph (b)(9)(i)(B) does not adopt the approach in ANSI/ASC A14.3–2008. As discussed above, evidence in the record shows that cages and wells do not prevent workers from falling off ladders or protect workers from injury if they fall (e.g., Exs. 113; 155; 185; 198; OSHA–S041–2006–0666–0198). OSHA believes the final rule, requiring that employers ensure new fixed ladders are equipped with ladder safety systems or personal fall arrest systems, is more protective than ANSI/ASC A14.3–2008. In addition, OSHA believes the final rule is easier to understand and follow than specifying the type of fall protection employers must provide based on the length of the worker’s climb, as A14.3–2008 requires.

Replacement. Final paragraph (b)(9)(i)(C) requires that employers ensure when a fixed ladder, cage, or well, or any portion of a section thereof is replaced, a personal fall arrest system or ladder safety system is installed in at least that section of the fixed ladder, cage, or well where the replacement is located. Unlike final paragraph (b)(9)(i)(B), which does not become effective until November 19, 2018, any replacement installed after the final rule becomes effective, which is January 17, 2017, must be equipped with a ladder safety system or personal fall arrest system.

Final paragraph (b)(9)(i)(C) does not require that employers install ladder safety or personal fall arrest systems when they make minor repairs to fixed ladders, cages, or wells, such as replacing a bolt or repairing a weld on a cage. However, when employers determine that they cannot simply make a repair to a section or a portion of a section of a fixed ladder, cage, or well but must replace that portion or section, employers must ensure the replacement is equipped with a ladder safety or personal fall arrest system. OSHA believes the inspection requirement in final § 1910.22(d) will help employers identify when simple repairs or corrections will be adequate and when the situation, such as a condition that affects the structural integrity of the fixed ladder, cage, or well, necessitates replacement of the fixed ladder, cage, or well section.

OSHA also notes that when “a portion of a section” of a fixed ladder, cage, or well needs replacement, the final rule only requires the employer to install a ladder safety or personal fall arrest system in that “section of the fixed ladder, cage, or well where the replacement is located.” The final rule

does not require employers to install a ladder safety or personal fall arrest system on the entire fixed ladder when a portion of one section needs replacement. For example, only part of a 50-foot section of a cage, well or multi-section ladder might need replacement because of damage. Final paragraph (b)(9)(i)(C) only requires that the employer replace that 50-foot section of the ladder, cage, or well with a ladder safety system or personal fall arrest system, not all sections. OSHA believes that a "section" of a fixed ladder equipped with a cage or well most likely will not exceed 50 feet. In this regard, ladder sections are the length of ladder between landings or platforms, and final paragraph (b)(9)(iii) requires that fixed ladders that have cages or wells must have landing platforms at least every 50 feet.

The approach ANSI/ASC A14.3–2008 follows when existing fixed ladders are replaced, modified, or repaired differs from the final rule in two respects. First, when existing fixed ladders are replaced, modified, or repaired, the ANSI/ASC standard specifies that employers may install cages or wells instead of ladder safety systems or personal fall arrest systems in some situations (see discussion of final paragraph (b)(9)(i)(B)). Second, the ANSI/ASC standard requires that employers only have to install cages, wells, or ladder safety systems when they make repairs to more than 25 percent of the whole ladder. OSHA believes that requiring employers to install personal fall arrest or ladder safety systems when repairs necessitate replacement of a portion of a fixed ladder, cage, or well is more protective than allowing employers to wait until more than 25 percent of the fixed ladder is in need of repair. In fact, the final rule prohibits that approach. Section 1910.22(d)(2) requires that hazardous conditions be repaired immediately and, if that is not possible, guarded so workers cannot use the walking-working surface until it is fixed (final § 1910.22(d)(2)). Moreover, as discussed above, the record indicates that installing ladder safety systems or personal fall arrest systems instead of cages or wells also is more protective.

Again, this provision does not prohibit employers from keeping those portions of a cage or well that are functioning properly, or installing a new cage or well, provided the employer also installs a personal fall arrest or ladder safety system as final paragraph (b)(9)(i)(B) requires, and the cage or well does not interfere with the fall protection system.

Final deadline. Finally, final paragraph (b)(9)(i)(D) establishes the final deadline for employers to ensure that all fixed ladders that extend more than 24 feet above a lower level are equipped with ladder safety or personal fall arrest systems, which, as mentioned, is 20 years after OSHA publishes the final rule. By that date (November 18, 2036), and thereafter, employers must ensure that all fixed ladders are equipped with personal fall arrest or ladder safety systems, even if the ladders have cages or wells.

OSHA set the extended phase-out period to take into account normal replacement and average useful life of fixed ladders, cages, and wells. After 20 years, OSHA estimates that the large majority of fixed ladders will have been replaced or in need of replacement. Even ANSI/ASC A14.3–2008 notes that while "[fixed] ladders are designed for extended service," they "are neither designed nor intended to possess an infinite safe useful life" (Section 9.1.3).

OSHA also believes the extended phase-out lessens the compliance burden on employers, provides a smooth transition to update ladder systems, and allows employers to install ladder safety and personal fall arrest systems according to normal replacement schedules. In addition, OSHA believes that, through replacement and new installations, the vast majority of fixed ladders will have ladder safety or personal fall arrest systems before the time the final deadline arrives.

Final paragraph (b)(9)(ii) adds new requirements for one-section fixed ladders that are equipped with personal fall arrest systems or ladder safety systems and fixed ladders equipped with those systems on more than one ladder section. For these ladders, the final rule requires that employers ensure:

- The personal fall arrest or ladder safety system provides protection throughout the entire vertical distance of the ladder, including all ladder sections (final paragraph (b)(9)(ii)(A)); and
- The ladder has rest platforms provided at least every 150 feet (final paragraph (b)(9)(ii)(B)).

In final paragraph (b)(9)(ii)(A), OSHA clarified the proposed language ("vertical distance") so the Agency could eliminate the need for the proposed note to paragraph (b)(9). OSHA stresses that the entire vertical distance of a fixed ladder includes all sections of a ladder, as well as any vertical distance in between ladder sections (sometimes referred to as "entire length of climb"). This means

that employers must protect workers for the entire vertical distance of fixed ladders equipped with ladder safety or personal fall arrest systems. The final provision also addresses the hazard of attempting to connect to a ladder safety or personal fall arrest system part way through a climb (*i.e.*, at 24 feet), which would require that the worker release one hand from the ladder, and thereby increase the risk of falling. This requirement is consistent with the construction fall protection standard and ANSI A14.3–2008 (Section 7.1.6).

OSHA notes that final paragraph (b)(9)(ii)(A) does not apply when only one section of a multiple-sectioned fixed ladder has a personal fall arrest system or ladder safety system and the other sections have only cages or wells. In this case, final paragraph (b)(9)(i)(C) applies, and employers need only ensure that the ladder safety or personal fall arrest system protects the worker during that section of the climb. However, when one-section fixed ladders and multiple sections of a fixed ladder have a ladder safety or personal fall arrest system, final paragraph (b)(9)(ii)(A) applies, and the employer must ensure the system protects the worker throughout the entire climb. The Agency does not believe that complying with final paragraph (b)(9)(ii)(A) should pose difficulties for employers. Rather, OSHA believes that if employers must install a ladder safety or personal fall arrest system, it is likely they will install the system on the entire fixed ladder (including all ladder sections). This is particularly true if the employer anticipates that other sections of the fixed ladder, cage, or well also will need replacement at some point.

Paragraph (b)(9)(ii)(B), like the proposal, requires that employers ensure fixed ladders that have personal fall arrest or ladder safety systems also have landing platforms at intervals of at least every 150 feet. This final provision generally is consistent with OSHA's construction ladder standard and ANSI A14.3–2008. OSHA's ladder standard for construction requires that fixed ladders with self-retracting lifelines have rest platforms every 150 feet, while the ANSI standard requires that fixed ladders equipped with ladder safety systems have rest platforms at the same intervals (Section 4.1.4.2). OSHA received no comments on the proposed provision and finalizes it as discussed.

Final paragraph (b)(9)(iii), like proposed paragraph (b)(9)(ii)(C), applies during the gradual phase out of cages and wells. The final rule requires that employers ensure ladder sections that have cages or wells:

- Are offset from adjacent sections (final paragraph (b)(9)(iii)(A)); and
- Have landing platforms provided at maximum intervals of 50 feet (final paragraph (b)(9)(iii)(B)).

Final paragraph (b)(9)(iii) is the same as the ladder standard for construction (§ 1926.1053(a)(19)(iii)). ANSI/ASC A14.3–2008 requires that each section of multiple section ladders equipped with only cages or wells be horizontally offset from adjacent sections and have landing platforms to provide safe access/egress (Section 4.1.4.1). Figure 5a in the A14.3 standard specifies platform landings at intervals of at least 50 feet. The existing rule in § 1910.27(d)(2), however, requires landing platforms at 30-foot intervals if the fixed ladder has a cage or well, and at 20-foot intervals when there is no cage or well. OSHA based the existing rule on the ANSI A4.13–1956 rule in effect at the time. OSHA believes that making final paragraph (b)(9)(iii) consistent with the construction ladder requirements and the current ANSI A14.3–2008 standard will allow workers who perform both general industry and construction activities to use the same fixed ladders while cages and wells are being phased out. OSHA notes that once employers equip fixed ladders with a ladder safety or personal fall arrest system this provision no longer applies, even if the ladder also still has the cage or well.

David Hoberg, with DBM Consultants, supported the provision requiring that fixed ladders have landing platforms, stating:

[H]aving climbed ladders of up to 125 feet and supervised persons using them, you would not believe the difference a landing makes. A hand cramping stops the climb. And try climbing a ladder as a first responder wearing 100 lbs. of gear where there is no landing to stage equipment or rest or take action (Ex. 206).

The provision is finalized with minor reorganization for clarity.

Final paragraph (b)(9)(iv) is a new provision OSHA added to the final rule that allows employers to use cages and wells in combination with personal fall arrest and ladder safety systems, provided the cages and wells do not interfere with the operation of the system. The proposed rule did not specifically address this issue, but ANSI A14.3–2008 (Section 4.1.6) allows the use of ladder safety systems in combination with a cage. OSHA is adding this provision to clarify that employers do not have to remove cages or wells when they install a required ladder safety or personal fall arrest system, provided the cage or well does not interfere with the operation of the required ladder safety or fall protection

system. If a cage or well prevents a personal fall arrest or ladder safety system from operating properly, then the employer must remove the cage or well to protect workers from falling or otherwise incurring an injury.

OSHA received one comment about using ladder safety or personal fall arrest systems in combination with cages or wells. Ellis urged that OSHA prohibit the use of ladder safety devices inside ladder cages because the rear bars of ladder cages can “pitch the body forward which is tantamount to free fall” (Ex. 155). The Agency believes that the language addressing interference in final paragraph (b)(9)(iv) resolves Ellis’ concern without limiting employer flexibility or compromising worker safety.

Outdoor advertising. Final paragraph (b)(10) addresses fall hazards on fixed ladders used in outdoor advertising (billboards). Final paragraph (b)(10), in combination with final paragraph (b)(9), revises the proposed rule to require that employers ensure their workers use fall protection while climbing fixed ladders that extend more than 24 feet above a lower level. This provision ensures that workers in outdoor advertising will have the same protection from fall hazards as other general industry workers who climb fixed ladders.

The effect of the final rule is to phase out the fall protection exception that OSHA established in the 1991 Gannett variance (56 FR 8801 (3/1/1991)) and the 1993 directive extending the variance to the entire outdoor advertising industry (Fixed Ladders Used on Outdoor Advertising Structures/Billboards in the Outdoor Advertising Industry, STD 01–01–014 (1/26/1993)). (Hereafter, the Gannett variance and OSHA directive are collectively referred to as “outdoor advertising directive.”) The outdoor advertising directive excepted that industry from complying with existing requirements that fixed ladders have cages or wells (existing § 1910.27(d)(1)(ii)), and landing platforms (existing § 1910.27(d)(2)). The effect of the directive is that workers in the outdoor advertising industry may climb fixed ladders, in some situations, without conventional fall protection (*e.g.*, cages, wells, and ladder safety and personal fall arrest systems), provided employers ensure that:

- Each worker wears a safety belt or harness with an appropriate 18-inch rest lanyard when climbing up to 50 feet or heights up to 65 feet from grade on a combination ladder consisting of a portable ladder and a fixed ladder;
- Each worker keeps both hands free of tools or materials when climbing;

- Each worker uses a ladder safety system for climbs on fixed ladders that exceed 50 feet or when the ladder ascends to heights that exceed 65 feet above grade;

- Each worker who climbs fixed ladders equipped with ladder safety devices uses those devices properly and follows appropriate procedures for inspection and maintenance of those devices;

- The employer ensures proper maintenance and use of ladder safety devices that are installed on fixed ladders;

- Each worker uses an appropriate fall protection system after reaching the work position; and

- Each qualified climber receives training and demonstrates the physical capability to perform necessary climbs safely. In this regard, the employer must ensure that: The worker’s physical condition is such that climbing will not impair the worker’s health or safety; the worker completes training consisting of classroom training, observing an experienced qualified climber, and actual climbing under close supervision using redundant safety equipment; and the worker works without fall protection only after demonstrating the necessary ability and skill in climbing (STD 01–01–014).

The proposed rule would have codified the specifications contained in the outdoor advertising directive, thus allowing outdoor advertising workers to continue climbing fixed ladders without fall protection so long as they complied with all of the provisions the directive included.

The final rule, however, does not adopt the proposal. Instead, final paragraph (b)(10)(i) specifies that the fall protection requirements for fixed ladders in final paragraph (b)(9) also apply to fixed ladders used in outdoor advertising. This means that outdoor advertising employers must ensure, in accordance with final paragraph (b)(9)(i)(A), that fixed ladders are equipped with a ladder safety system, personal fall arrest system, cage, or well before November 19, 2018. In addition, they must follow the schedule in final paragraph (b)(9)(i) for gradually phasing in the installation of ladder safety and personal fall arrest systems on fixed ladders.

Final paragraph (b)(10)(i) also requires that employers in outdoor advertising follow other provisions in revised subparts D and I, such as the inspection and maintenance requirements in final § 1910.22, the training requirements in final § 1910.30, and the criteria for personal fall protection systems in § 1910.140.

Final paragraph (b)(10)(ii) establishes the requirements that outdoor advertising employers must follow during the phase-in period (two years) they have to install a cage, well, ladder safety system or personal fall arrest system. During this period when outdoor advertisers have not yet installed fall protection, employers must ensure that each worker:

- Receives training and demonstrates the physical capability to perform the necessary climbs in accordance with final § 1910.29(h) (final paragraph (b)(10)(ii)(A));
- Wears a body harness equipped with an 18-inch rest lanyard (final paragraph (b)(10)(ii)(B));
- Keeps both hands free of tools or material while climbing the fixed ladder (final paragraph (b)(10)(ii)(C)); and
- Is protected by a fall protection system upon reaching the work position (final paragraph (b)(10)(ii)(D)).

The requirements in final paragraph (b)(10)(ii) are limited and temporary. First, they only apply to fixed ladders used in outdoor advertising that are not equipped with any type of fall protection. Once a fixed ladder used for outdoor advertising is equipped with one of these systems, the requirements in final paragraph (b)(10)(ii) no longer apply. Instead, the requirements in final paragraphs (a) and (b)(9), final § 1910.29, and final § 1910.140 apply to outdoor advertising employers and fixed ladders used in outdoor advertising.

Second, final paragraph (b)(10)(ii) is only a temporary provision. It is applicable only before November 19, 2018. As of November 19, 2018, final paragraph (b)(9)(i)(A) requires that employers must ensure all existing fixed ladders, including those used for outdoor advertising activities, are equipped with a cage, well, ladder safety system, or personal fall arrest system. Thus, as of November 19, 2018, the requirements in final paragraph (b)(10)(ii) no longer apply and the provision, in essence, expires. In their place, as stated above, the requirements in paragraphs (a) and (b)(9), as well as other fall protection system requirements in the final rule, apply to outdoor advertising employers. OSHA notes that the requirements in final § 1910.29(h), which apply when workers climb fixed ladders without fall protection to perform outdoor advertising activities, also are temporary. As of November 19, 2018, the requirements in § 1910.29(h) no longer will apply since, in accordance with final paragraph (b)(9)(i)(A), all fixed ladders used for outdoor advertising will be required to be equipped with a personal fall arrest

system, ladder safety system, cage, or well.

Final paragraph (b)(10)(ii)(A) requires that outdoor advertising employers ensure that each worker who climbs a fixed ladder that is not equipped with a personal fall arrest system, ladder safety system, cage, or well, receives training and demonstrates the physical ability to climb fixed ladders.

Employers may comply with the training final paragraph (b)(10)(ii)(A) requires by ensuring that workers have completed a training or apprenticeship program, provided the program includes hands-on training on climbing ladders safely, performance observation combined with formal classroom or on-the-job training, and retraining as necessary (final § 1910.29(h)(2) and (3)).

OSHA notes that employers must ensure the requirement in final paragraph (b)(10)(ii)(A) to demonstrate physical capability must include either a physical examination or observation of the worker performing actual climbing activities (final § 1910.29(h)(1)). Final § 1910.29(h) discusses in detail the training and physical capacity requirements in final paragraph (b)(10)(ii)(A). OSHA notes that this training is in addition to the training outdoor advertising employers must provide to their workers under final § 1910.30.

Final paragraph (b)(10)(ii)(B) requires that outdoor advertising employers ensure workers who climb fixed ladders without fall protection wear body harnesses equipped with an 18-inch rest lanyard. OSHA's intention in requiring that outdoor advertising workers wear body harnesses with rest lanyards is that employers must ensure workers tie off to the fixed ladder when they need to rest during the climb.

The final rule differs from proposed (b)(10)(i) and outdoor advertising directive, both of which permit outdoor advertising employers to provide a body harness or body belt for workers to use for resting during a climb. However, as discussed in final § 1910.140, the final rule does not permit the use of body belts as a part of a personal fall arrest system; thus, OSHA deleted body belts from final paragraph (b)(10)(ii)(B). This revision also makes the final provision consistent with OSHA's construction industry rule, which also does not allow use of body belts for personal fall arrest (§ 1926.502(d)).

Final paragraph (b)(10)(ii)(C) requires employers to ensure that workers engaged in outdoor advertising keep both hands free of tools or material when climbing fixed ladders. This requirement ensures that workers use their hands exclusively for climbing and

not carrying tools and material up and down fixed ladders. When workers climb fixed ladders without fall protection, it is essential that they maintain balance and body control. Carrying tools and materials in their hands while they climb may cause workers to lose their balance, which could result in a fall. Both the proposed rule at paragraph (b)(10)(vi) and the outdoor advertising directive include this requirement. In addition, it is consistent with final paragraphs § 1910.23(b)(12) and (13), the construction standard (§ 1926.1053(b)(21) and (22)), and ANSI A14.3–2008 (Section 9.2.1 and 9.2.2).

Final paragraph (b)(10)(ii)(D), like the proposed rule at paragraph (b)(10)(vii) and the outdoor advertising directive, requires outdoor advertising employers to provide workers who climb fixed ladders with, and ensure that they use, a fall protection system once they reach the work position/platform. Thus, when workers step onto the work platform, they must be tied off or otherwise protected from falling (*e.g.*, guardrails). OSHA believes this requirement is necessary because outdoor advertising employers typically install platforms at great heights. The final provision allows employers to use any type of fall protection system specified by final paragraph (b)(1) to protect workers from falling off an unprotected side or edge, including guardrail, safety net, travel restraint, positioning, or personal fall arrest systems.

OSHA requested comment in the proposed rule about eliminating the qualified climber exception for the outdoor advertising industry and instead require fixed ladders used in outdoor advertising to be equipped with the same fall protection as other fixed ladders under the general industry standard (75 FR 28869). In response, OSHA received many comments. A number of commenters, including several fall protection equipment manufacturers, safety organizations, and safety professionals who provide fall protection services, opposed retaining the qualified climber exception in the final rule (Exs. 155; 185; 198; 250). For several reasons, these commenters opposed including in the final rule a qualified climber exception for any industry. These reasons included the dangers of climbing without fall protection; the questionable need for the qualified climber exception in the outdoor advertising industry when compared to other industries; and the ready availability of feasible and easy to use fall protection (*e.g.*, Exs. 155; 185; 198; 205; 250). For example, American Society of Safety Engineers (ASSE) said:

The idea that it is somehow acceptable to climb high distances without fall protection contradicts OSHA's proposed fixed ladder standard requiring a ladder safety system or a cage/well when the total length of a climb exceeds 24 feet. Our members fail to understand why fixed ladders between 24–50 feet in height used in outdoor advertising should be different than other industry ladders used at the same heights. Further, the technology is readily available to provide protections for the fixed ladder (Ex. 127).

ISEA and CSG also voiced opposition to a qualified climber exception for outdoor advertising:

Their situation is not unique. Right now there are many systems available to provide fall arrest as soon as these workers leave the ground. In fact, this type of equipment is used today, so the burden on employers is slight.

OSHA asks about technological and economic feasibility of fall protection for this type of work. Because this industry is constantly improving its offerings and developing new solutions for employers and employees, it is safe to say there has been marked improvement in ladder systems over the past 20 years. In addition, ladder climbing systems are becoming increasingly common.

Finally, Assistant Secretary Michaels has been speaking about fostering a greater culture of safety in U.S. workplaces. Providing an exemption from use of fall protection for those working at dangerous heights seems to run counter to this message (Exs. 185; 198).

The Society of Professional Rope Access Technicians (SPRAT) agreed, saying:

[I]n light of advances in technology and accepted practices for safe alternatives such as Rope Access, twin lanyards, and lead climbing, elimination of the Qualified Climber provision may be timely and appropriate. Variations on these concepts are already accepted methodologies in international fall protection regulations, including ISO, BSA, and Australia. Granted, a 100% tie-off approach may be onerous to implement all at once, but implementation could be phased over several years to help ameliorate the impact (Ex. 205).

Ellis made a similar comment:

This concept of a safe climber who does not need fall protection on ladders or step bolts for climbing towers is a timeworn concept whose day has passed. Protection should be required. Use of rope access teams for work at heights . . . and always using fall protection is what has already arrived in many countries of the world including most of Europe, Australia and South Africa (Ex. 155).

Finally, Damon, Inc., opposed the qualified climber exception because it suggests that older, experienced workers climb better with age while data actually shows that “older workers have a disproportionate share of fatal falls from ladders” (Ex. 250).

Many commenters, primarily those in the outdoor advertising industry (Exs. 121; 260; 359; 369) and employees of Lamar Advertising (Lamar) (e.g., Exs. 75; 80; 81; 82; 83; 84; 85; 86; 87; 88; 89; 90; 91; 92; 93; 94; 95; 99; 104; 105; 106; 128), supported codifying the outdoor advertising directive for fixed ladders used in outdoor advertising. For example, Clear Channel Outdoor, Inc. (CCO), and the Outdoor Advertising Association of America (OAAA) supported codifying the outdoor advertising directive because the industry has been operating under it for over two decades (Exs. 121; 329 (1/18/2011, pgs. 113–116)). Many Lamar employees also said they followed the requirements of the outdoor advertising directive for more than two decades and are familiar with the requirements. In this regard, Joseph Shopshear, a Lamar operations manager, said Lamar based its worker safety programs on the Gannett variance, and that “[t]he Gannett Variance is a very important first step in our safety program and other safety related programs and has been since my employment began with Lamar” (Ex. 81). Similarly, William DeVine, another Lamar operations manager, said the Gannett variance is the “forefront” of the company’s safety meetings, the qualified climber qualifications, and the “backbone” of their training program (Ex. 94). Therefore, he:

[U]rge[s] OSHA to allow this variance to remain in effect. Any other legislation could immediately affect my job and others around me . . . I do support the Gannett Variance wholeheartedly and request that it remain permanent in the newest legislation . . . The Gannett Variance as written will continue to protect me and my fellow climbers and provide the safest of work environments . . . (Ex. 94)

Several commenters said that OSHA should codify the qualified climber exception for outdoor advertising because they have not experienced any fatalities related to climbing fixed ladders without fall protection, and falls are “extremely rare” (Exs. 106; 260; 329 (1/18/2011, pgs. 113–19); 369). For example, Mike Gentile, another Lamar operations manager, said, “There has been over a million climbs made by all billboard personnel in California in the past ten (10) years on fixed ladders. To date, I am not aware of one single fall” (Ex. 106). CCO, which asserted in its comments on the proposed rule that “CCO employees simply do not fall from fixed ladders” (Ex. 121), expanded on this assertion in its post-hearing comments, stating:

The past eighteen years has clearly established that the Gannett Variance works

very well for this industry. There have been zero fatalities and industry is aware of only one fall from a fixed ladder, one, despite literally millions of climbs. The hard evidence proves that the variance works and the numbers could only get worse if the variance is not codified into the new regulations (Ex. 369).

OAAA, reporting on information from industry members, said, “From a safety standpoint, our companies report that no deaths due to falls from fixed ladders have occurred in the past five years; of the 15,840,000 climbs over the past 5 years, our companies are aware of only one fall from a fixed ladder” (Ex. 260). OAAA estimated that its members, which it said comprise 90 percent of the market, have a total of 1,800 climbers.

The International Sign Association (ISA) also supported retaining the qualified climber exception because of the industry’s safety record, noting, “It is our understanding that the safety record of outdoor advertising professionals has been excellent over the last decade, and that changing the rule would impose unnecessary costs and technical requirements” (Ex. 161).

CCO said it would be too costly to retrofit fixed ladders with fall protection (Exs. 121; 369). They claimed that it would cost the company in excess of \$80 million to retrofit its 60,000 existing structures (Ex. 121).⁵⁵ In its post-hearing comments, CCO revised and supplemented its cost information on retrofitting fixed ladders with fall protection, noting, “[T]he installation of cages and wells would cost approximately \$1,400 for first 20 feet and \$1,050 for each twenty foot section after. Accordingly the cost depends upon the height of the unit” (Ex. 369). CCO stated further:

Clear Channel Outdoor is one of the largest outdoor advertising businesses in the USA. Many of the remaining companies are very small “mom and pop” types of operations. While Clear Channel has always met or exceeded regulatory requirements, the additional cost to comply would not only be a significant impact on the company, it could potentially put the smaller operations out of business due to additional financial burden to meet the new requirements.

Clear Channel Outdoor has in excess of 20,000 structures domestically. If one were to remove the structures greater than fifty feet that were address[ed] earlier in these

⁵⁵ CCO submitted a pre-hearing comment, Ex. 121, and a post-hearing comment, Ex. 369. In the earlier of CCO’s two comments, the company appeared to be describing compliance costs for the entire set of billboard “faces” owned and operated by the company (60,000 structures, \$80 million), whereas in the later comment the company appeared to be restricting its cost discussion to 20,000 billboard structures that reach elevations above a certain height and require a compliance response.

questions you would be left with approximately 16,000 structures. If one were to divide that number in half to allow for structures less than twenty-four feet of ladder climber and specialty structures without ladders, there would still be around 8,000 structures that would be affected by the proposed codification of the Gannett Variance with heights in excess of twenty-four feet of climb (twenty-five feet is the typical average mentioned in question 1). To install cages on this number of structures would be approximately \$12,000,000. To install vertical fall protection would be approximately \$2,200,000. While looking at the percentage of cost on new builds individually may not appear to be that much, to retrofit structures that are already in existence to meet new requirements would be extremely expensive.

Additionally, guardrails, cages and wells could potentially obscure advertising copy. This could result in a diminishment of sales and possibly have a catastrophic financial impact on all outdoor advertisers (Ex. 369).

Citizens for a Scenic Wisconsin, Inc. (CFSW), raised a similar concern about requiring fall protection on fixed ladders used for outdoor advertising. CFSW pointed out that the Federal Highway Administration allows catwalks or handrails for non-conforming billboards, and the Highway Beautification Act (HBA) of 1965 allows non-conforming billboards to remain in place until they are destroyed, abandoned, discontinued, or removed. CFSW concluded, "If existing non-conforming billboards cannot be safely serviced then their advertising message will eventually become obsolete or so weathered and worn that it will become discontinued or abandoned, and ordered removed without compensation as the HBA intended" (Ex. 217).

Two commenters supported applying the qualified climber option to industries other than outdoor advertising. For example, Verallia said limiting the qualified climber option only to outdoor advertising was "too restrictive," and recommended that OSHA expand the qualified climber provision to other industries, stating:

There are many other tasks that are routinely performed in general industry that are comparable. Without attempting to provide a comprehensive list of such tasks, one example is the infrequent, but not uncommon, need to climb a "smoke stack" in order to perform emissions testing. The "stack tester" is only at the elevated level for a relatively short amount of time. This task, and surely many others, are comparable to that of the "outdoor advertiser" and should also come within the proposed standard at 1910.28(b)(10) (Ex. 171).

OSHA notes that neither CCO nor OAAA supported allowing existing fixed ladders used for outdoor advertising to remain in place and

prospectively applying the fall protection requirements to fixed ladders erected in the future. OAAA said, "It could be difficult to support a grandfather provision due to the fact that a new regulatory requirement could foster inconsistent application of climbing methods which ultimately could increase overall risk to climbers. Essentially a double standard is created" (Ex. 359). OAAA stated further that "[t]here is concern that two training systems will be required in the future, one for grandfather structures and another separate program for new structures and fixed ladders. Thus, this can be costly as well as potentially strain overall company safety efforts" (Ex. 359). Finally, OAAA noted that "[w]e concur with the use of new technologies to protect our workers and professional climbers," but "recommend that OSHA not list specific equipment in the standard so as to give employers the flexibility to use new technologies as they become available" (Ex. 260). A number of Lamar employees agreed, saying that listing fall protection system in the final rule would make the rule "outdated as soon as it was published" (e.g., Exs. 75; 92; 93; 99; 101).

For a number of reasons, OSHA believes that it is necessary and appropriate to eliminate the qualified climber exception in the outdoor advertising industry. First, workers are at risk of death and injury climbing to elevated heights on fixed ladders without fall protection (no matter how often) and OSHA believes employers in outdoor advertising are aware of these risks. For example, CCO, one of the largest companies in the outdoor advertising industry, said they already have equipped a number of fixed ladders with fall protection systems (Ex. 369). CCO added that the average height at which those fall protection systems protect their workers is 18 feet, which is well below the height at which fall protection is required in the outdoor advertising directive. OSHA also notes that the outdoor advertising industry did not oppose the proposal's requirement that fixed ladders used in outdoor advertising be equipped with ladder safety systems or personal fall arrest systems when those ladders exceed 50 feet or for climbs that exceed 65 feet, which is an acknowledgement that workers climbing fixed ladders without fall protection are exposed to great risk.

As demonstrated in the FEA, falls from ladders are a significant cause of worker deaths and injuries. The FEA indicates that on average, falls kill 47 general industry workers and injure

10,716 workers each year. OAAA said their member companies reported no deaths and only one fall involving their 1,800 climbers for the years 2005 to 2010 (Ex. 260). OSHA's Integrated Management Information System (IMIS) data indicate that since the 1991 Gannett Variance there have been at least three falls from fixed ladders in the outdoor advertising industry, one of which resulted in death.⁵⁶

The IMIS data also show a large number of falls, in servicing outdoor advertising structures; however, the data do not identify the location of the workers on the structures when they fell (Ex. 393). Therefore, OSHA cannot determine definitively whether the falls were from fixed ladders. However, OSHA believes that at least some of these falls could have occurred while workers were climbing the fixed ladder or transitioning from the fixed ladder to the work platform because the incident narratives state that workers were not using fall protection (or were not tied off) when they fell. Since the outdoor advertising directive requires that employers ensure their workers use fall protection at all times when they are on work platforms, OSHA believes that workers may have been on fixed ladders or transitioning from fixed ladders to the work platform when they fell. As such, OSHA believes that there may actually be more than the three falls (noted above) related to climbing without fall protection.

Second, OSHA believes that requiring outdoor advertising employers to ensure their workers use ladder safety systems or personal fall arrest systems when they are on fixed ladders will reduce the risk of falls when workers are transitioning from fixed ladders to work platforms (or from the work platform to the fixed ladder). Stakeholders, including many Lamar Advertising workers, admitted that transitioning from fixed ladders to work platforms is an "important" safety concern (e.g., Exs. 85; 86; 90; 92; 103; 104; 105. *See also*, Ex. 329 (1/18/2011), p. 333). OAAA agreed, saying the final rule must ensure "safe transitions" from fixed ladders to landing surfaces (Ex. 260). IMIS data show falls occurred in the outdoor advertising industry when workers were

⁵⁶ OSHA derives IMIS data from investigations of employer accident reports. Since OSHA only requires that employers report accidents that involve a fatality or the hospitalization of three or more workers, the Agency believes that IMIS data may understate the number of non-fatal injuries. IMIS Fatality and Catastrophe Investigation Summaries are found on OSHA's Web site at: <http://www.osha.gov/pls/imis/accidentsearch.html>.

The referenced falls are in Ex. 393 under the following inspection numbers: 310696489; 126063924; and 126062694.

transitioning between the fixed ladder and the landing/work platform (Ex. 393). As such, OSHA finds that qualified climber training programs have not adequately addressed the significant risk associated with transitioning to/from fixed ladders without work platforms and the requirement that employers ensure workers use ladder safety systems or personal fall arrest systems while climbing fixed ladders is needed. Requiring that workers must be tied off at all times (both on the fixed ladder and work platform) will reduce the risk of worker falls during fixed ladder/platform transitions. For example, when workers leave the work platform they can slip or lose their balance when turning to climb back down the ladder. At this point the workers may not see the first rung on the ladder and must feel for a foothold as they transition from the platform to the fixed ladder. If workers are tied off, falls will be stopped even if their balance is lost, their foot slips off a ladder rung, or they lose their grip on the ladder or other hand hold.

Third, OSHA believes that requiring outdoor advertising employers to use fall protection on fixed ladders will help to ensure that their workers also continue to use fall protection (*i.e.*, be tied off) at all times when they are on outdoor advertising work platforms, which will reduce fatal falls from those platforms. The outdoor advertising directive, issued in 1993, requires that employers ensure their workers use fall protection at all times while on work platforms. However, IMIS data from 1993–2010 indicate that 23 falls from outdoor advertising work platforms occurred during that time because either employers did not provide fall protection for workers or did not ensure workers were properly tied off. Of those falls, 13 resulted in worker deaths (Ex. 393). OSHA believes if employers must provide and ensure workers use fall protection when they start climbing fixed ladders to work platforms that those workers will be more likely to remain tied off when they reach, and work on, the platforms.

OSHA notes that requiring that workers in outdoor advertising use fall protection when they climb fixed ladders makes the final rule consistent with the construction ladder standard (§ 1926.1053(a)(18) and (19)) and other standards the Agency recently revised (§§ 1910.269 and 1926.954). Those standards require that workers, including specially trained workers similar to qualified climbers in outdoor advertising, use fall protection while climbing fixed ladders, poles, towers,

and similar structures. For example, the construction ladder standard requires that employers provide workers climbing fixed ladders above 24 feet with, and ensure that they use, ladder safety devices, self-retracting lifelines (*i.e.*, personal fall arrest system), cages, or wells (§ 1926.1053(a)(19)).

OSHA's revised general industry (§ 1910.269) and construction (29 CFR part 1926, subpart V) electric power generation standards added a requirement that qualified employees must use fall protection while climbing or changing locations on poles, towers, or similar structures, unless the employer can demonstrate that fall protection is not feasible or presents a greater hazard to the employees (§§ 1910.269(g)(2)(iv)(C)(3) and 1926.954(b)(3)(iii)(C))(79 FR 20315 (4/11/2014)). As originally adopted, § 1910.269 (adopted by OSHA in 1994) did not require that qualified employees use fall protection when climbing poles, towers, and similar structures unless conditions (*e.g.*, ice, high winds, presence of contaminants) could cause workers to lose their grip or footing. However, because of the incidence of fall fatalities and ready availability of personal fall protection systems (*e.g.*, personal fall arrest systems, pole straps), OSHA added a provision to § 1910.269 specifically requiring that qualified employees use fall protection (§ 1910.269(g)(2)(iv)(C)(3))(79 FR 20399–20401). OSHA believes the rationale for eliminating the qualified employee exception from § 1910.269 also is applicable to outdoor advertising.

OSHA is requiring that outdoor advertising employers provide fall protection on fixed ladders because it is clear that, like the utility industry, there are technologically feasible means of fall protection available that are currently in use to protect workers in outdoor advertising. Indeed, since 1993 the outdoor advertising directive has required that employers install ladder safety systems, and ensure that workers use them, when climbs on fixed ladders exceed 50 feet or when the fixed ladder ascends to a height of more than 65 feet above grade. During the period since OSHA issued the directive, manufacturers developed new types of personal fall protection systems, specifically personal fall arrest systems, for climbing fixed ladders, and these systems are readily available, effective, and easy to use (*e.g.*, Exs. 127; 185; 198). OSHA included these systems in the construction fall protection standard issued in 1994, and their use is commonplace today. As mentioned, OSHA also required the use of fall protection systems, such as personal fall

arrest systems, in the 2014 revisions to § 1910.269 and § 1926.954. OSHA also notes that, in the current rulemaking, several stakeholders submitted information to the record about fall protection systems that are readily available and effective in protecting workers climbing fixed ladders (Exs. 127; 155; 185; 198; 205).

The record also shows that it is economically feasible for the outdoor advertising industry to comply with the final requirement to ensure that employers provide and ensure their workers use fall protection systems while climbing fixed ladders in outdoor advertising. Many, if not most, fixed ladders manufactured today have ladder safety systems or personal fall arrest systems (*i.e.*, self-retracting line or cable) that meet the requirements of final paragraph (b)(9) of this section and final § 1910.29. The FEA and the record for this rulemaking indicate that these systems are reasonably priced and economically feasible. In the FEA, OSHA estimates that the cost of purchasing and installing a ladder safety system or personal fall arrest system is about \$1,050. In their post-hearing comments, CCO's cost estimates for installing ladder safety or personal fall arrest systems are lower than OSHA's cost estimates, suggesting that OSHA's estimate is conservative (Ex. 369).

OSHA also believes the fall protection requirement is economically feasible because the FEA estimates that employers will need to equip only a small percentage of existing outdoor advertising structures with fall protection. OAAA estimates there are approximately 450,000 existing structures (Exs. 260; 359; 369). Employers in outdoor advertising will not have to install fall protection on fixed ladders that do not extend more than 24 feet above a lower level (final paragraph (b)(9)(i)(A)) or that already are equipped with fall protection. As such, in the FEA, OSHA estimates that employers will need to equip only about 21,000 existing outdoor advertising structures with a fall protection system by November 19, 2018. In the Preliminary Economic Analysis (PEA) of the proposed rule, OSHA included a similar estimate (*i.e.*, 20,490 outdoor advertising structures extend more than 20 feet above a lower level); OAAA provided this estimate to OSHA based on their member comments and a survey (Ex. OSHA–2007–0072–0046, p. A–9). Neither OAAA nor any other employer in the outdoor advertising industry challenged OSHA's estimate. In fact, OAAA's and CCO's comments generally support OSHA's conclusion that employers will need to equip only

a small percentage of existing outdoor advertising structures with fall protection systems (Exs. 260; 359; 369).

The framework of the final rule, when read in the context of final paragraph (b)(9)(i) of this section, provides employers with substantial control flexibility, which further ensures the final rule is economically feasible. Specifically, the final rule allows outdoor advertising employers to equip existing ladders (that have no fall protection) with a cage, well, ladder safety system, or personal fall arrest system (final paragraph (b)(9)(i)(A)), while the existing rule, absent the outdoor advertising directive, would require outdoor advertising employers to equip the fixed ladders with cages or wells (existing § 1910.27(d)(1)(ii)). As mentioned earlier in this preamble, this flexibility allows employers to equip fixed ladders with the least costly fall protection system, which the record indicates are ladder safety or personal fall arrest systems (Ex. 369; *see also* FEA). OSHA notes that CCO, one of the largest outdoor advertising companies, said it would cost approximately \$12 million to install cages or wells on 8,000 existing fixed ladders, but only \$2.2 million to install ladder safety systems or personal fall arrest systems (*i.e.*, “vertical fall protection”) on those fixed ladders (Ex. 369).

In addition, giving employers in outdoor advertising two years to install a fall protection system on fixed ladders lessens the economic impact of the final rule and further shows the requirement is economic feasible. For example, it gives employers time to identify and evaluate various types of fall protection systems, negotiate with manufacturers and vendors to select the most cost-effective system that best satisfies their needs, and train workers in the use of that equipment. Moreover, OSHA notes that the final rule gives outdoor advertising employers two years to comply with the requirement that their workers use fall protection while climbing fixed ladders while revised § 1926.954 gave employers only one year to comply with the fall protection requirement.

Gradually phasing in over 20 years the requirement that fixed ladders be equipped with ladder safety systems or personal fall arrest systems also significantly lessens the economic impact on employers, including those in outdoor advertising. To illustrate, if outdoor advertising employers currently use fixed ladders equipped only with cages or wells, the final rule gives these employers 20 years to install ladder safety or personal fall arrest systems. This extended phase-in period allows

employers to install fall protection systems as part of their normal replacement or business cycles rather than retrofitting fixed ladders immediately. In sum, OSHA believes the combination of flexibility to use controls that are less expensive than those the existing rule required, extended compliance time, and gradual phase-in of ladder safety systems and personal fall arrest systems ensures the final rule is economically feasible and will not threaten the industry’s “long-term profitability” or substantially alter its competitive structure. (*Forging Indus. Ass’n v. Secretary of Labor*, 773 F.2d 1436, 1453 (4th Cir. 1985) (en banc) (*Noise*)).

Finally, OSHA believes requiring employers in outdoor advertising to provide and ensure that workers use fall protection when climbing fixed ladders is reasonable and appropriate because, as a number of commenters said, the outdoor advertising industry and the fixed ladders it uses are not unique with regard to fall protection (Exs. 155; 185; 198). Therefore, OSHA believes that it is no longer necessary or warranted for it to except the outdoor advertising industry from the requirements to use fall protection while climbing fixed ladders. Stakeholders in the outdoor advertising industry did not argue that the elevated heights encountered in outdoor advertising are not dangerous, or that fall hazards or work conditions in outdoor advertising are unique compared to other industries. Moreover, they did not argue that the fall protection systems used by workers in other industries when climbing fixed ladders will not work, or are not a feasible means of worker protection, in the outdoor advertising industry.

Regarding comments recommending that OSHA not list specific fall protection systems in the final rule because such a list would soon become outdated, OSHA notes that the Agency has dealt with issues like this in the past. If an employer has information about a new method of fall protection that will provide worker protection equivalent to the protection afforded to workers by the final rule, it can approach the Agency and seek permission to use it through a request for interpretation or a variance.

Stairways. Final paragraph (b)(11), which generally is consistent with existing §§ 1910.23(d)(1) and 1910.24(h) and proposed paragraph (b)(11), requires that employers protect workers from falling off stairway landings and the exposed sides of all stairways. Stairways, as defined in the final rule in § 1910.21(b), include standard stairs,

ship stairs, spiral stairs, and alternating tread-type stairs.

Final paragraph (b)(11)(i), like the proposal, requires that employers ensure each worker exposed to an unprotected side or edge of a stairway landing that is four feet or more above a lower level is protected by a guardrail⁵⁷ or stair rail system.⁵⁸ The final requirement is consistent with the requirements for stairway landings specified by the existing general industry standard in § 1910.24(h) and the construction standard in § 1926.1052(c)(12). The final provision is also consistent with A1264.1–2007 (Section 7.1), the National Fire Protection Association (NFPA) Life Safety Code—NFPA 101–2012 (Section 7.1.8), and the International Code Council International Building Code (IBC)—IBC–2012 (Section 1013.2). OSHA notes that NFPA and IBC require guards on open-sided walking surfaces located more than 30 inches above the floor or grade below. Unlike final paragraph (b)(1), which allows employers to protect workers using one of several fall protection options, final paragraph (b)(11)(i) requires that employers provide guardrails or stair rails on unprotected sides and edges of stairway landings and stairways. OSHA believes that limiting the fall protection options to stair rails or guardrails is necessary, because the other fall protection options in final paragraph (b)(1) (*i.e.*, safety net, travel restraint, and personal fall arrest systems) are not appropriate or practical to use on stairways, which workers use regularly and routinely to access workplace areas. Using the other options could prevent, or significantly encumber or impede, workers from using the stairways and freely moving around the worksite. By contrast, guardrail and stair rail systems provide continuous protection while allowing workers to freely access stairs and worksites.

Final paragraph (b)(11)(ii), consistent with existing § 1910.23(d)(1) and proposed paragraph (b)(11)(ii), requires that employers ensure each flight of stairs having at least three treads and at least four risers is equipped with a stair rail system and handrails as specified in Table D–2. Table D–2 specifies the type and number of stair rails and handrails employers must provide based on the width and configuration of the stairs.

⁵⁷ The final rule defines guardrail system as a barrier erected along an unprotected side, edge or other walking-working surface to prevent workers from falling to a lower level (final § 1910.21(b)).

⁵⁸ The final rule defines stair rail or stair rail system as a barrier erected along the exposed or open side of stairways to prevent workers from falling to a lower level (final § 1910.21(b)).

NFPA commented on the proposed table, saying that it was potentially misleading (Ex. 97). In particular, NFPA said the third column (“One open side”) did not clearly specify that, in addition to providing a handrail on the “one open side,” employers also must provide a handrail on the “enclosed side” (Ex. 97). NFPA noted that OSHA should not expect employers to know that they must meet the requirements for both the “enclosed side” and for “one open side” to be in compliance with the final rule. NFPA, therefore, made the following two recommendations to revise the third column of the proposed table: (1) For stairways that are 44–88 inches wide, NFPA recommended, “One stair rail system with handrail on open side and one handrail on enclosed side”; and (2) for stairways that are greater than 88 inches, NFPA recommended, “One stair rail system with handrail on open side, one handrail on enclosed side, and one intermediate handrail located in the middle of the stair.” OSHA agrees that NFPA’s recommendations clarify the information provided in the proposed table, and incorporates them in final Table D–2.

Final paragraph (b)(11)(iii), like the proposal, requires that employers ensure ship stairs and alternating tread-type stairs are equipped with handrails on both sides. Both of those types of stairs have slopes that are 50 to 70 degrees from the horizontal, and OSHA believes that workers need handrails on both sides to safely climb those stairs. This requirement is consistent with IBC–2012 (Section 1009.13 and .14) and NFPA 101–2012 (Section 7.2.11). OSHA did not receive any comments on the proposed provision and adopts paragraph (b)(11) with only minor changes for clarity.

Scaffolds and rope descent systems. Final paragraph (b)(12), like the proposal, requires that employers protect workers from falls who are working on scaffolds and who are using rope descent systems. The final rule defines a scaffold in part as a temporary elevated or suspended platform and its supporting structure, including anchorage points, that support workers, equipment, materials, and other items (final § 1910.21(b)). As defined in the final rule, a rope descent system, also known as controlled descent equipment or apparatus, is a suspension device that allows the worker to descend in a controlled manner, usually in a chair (seatboard) (final § 1910.21(b)).

Final paragraph (b)(12)(i), like the proposal, makes the general industry standard consistent with the construction standard by requiring the

employer to ensure that workers on scaffolds are protected from falling in accordance with 29 CFR part 1926, subpart L. The final rule deletes the existing general industry scaffold provisions and, instead, requires that employers comply with the requirements in the construction scaffold standards. The requirements in the construction scaffold standard are more comprehensive and up to date than the existing rule, which OSHA adopted in 1971. OSHA notes the existing rule, like the construction standard, requires that employers provide fall protection when workers on scaffolds are 10 feet or more above a lower level (see *e.g.*, existing § 1910.28(b)(15), (c)(14), (d)(7), (f)(15), (g)(5), (h)(8), (k)(5), (m)(7), (o)(2), (p)(7); § 1926.451(g)(1)).

Final paragraph (b)(12)(ii), like the proposal, requires that employers ensure workers using rope descent systems four feet or more above lower levels are protected from falling by a personal fall arrest system. OSHA reminds employers that if they use vertical lifelines to protect workers using RDS, the lifeline must be attached to a separate anchorage (see final § 1910.140(c)(12)). The construction fall protection standard includes a similar requirement (§ 1926.502(d)(15)). OSHA did not receive any comments on the proposed provision and finalizes it with only minor editorial change.

Work on low-slope roofs. Final paragraph (b)(13) is a new provision that establishes fall protection requirements when employees perform work on low-slope roofs. OSHA is adding this provision to make the general industry standard more consistent with the construction fall protection standard, which includes a provision addressing roofing work performed on low-slope roofs (§ 1926.501(b)(10)). Many stakeholders urged OSHA to incorporate the construction provision in the final rule (see *e.g.*, Exs. 121; 124; 164; 171; 180; 189; 192; 207; 226; 251).

The final rule defines low-slope roof as “a roof having a slope less than or equal to 4 in 12 (vertical to horizontal)” (§ 1910.21(b); see also § 1926.500(b)). A “4 in 12” slope means, for example, the slope does not exceed a 4-foot vertical rise for every 12 feet in the horizontal length of the roof.⁵⁹

⁵⁹In the preamble to the proposed rule, OSHA mistakenly indicated that a “4 in 12” slope is a slope that is 10 degrees or less. NIOSH noted correctly in its comments that “[a] slope of 10 degrees or less from the horizontal requires a slope of 2 in 12 (9.5 degrees)” (Ex. 164). Therefore, for the purposes of this final rule, a low-slope roof has a slope of 4 in 12 or less, which is a slope of less than 20 degrees.

Under paragraph (b)(13), the type of fall protection measures employers must use on low-slope roofs depends upon the distance they work from the roof edge.⁶⁰ The final rule divides work on low-slope roofs into three zones:

- Work performed less than 6 feet from the roof edge;
- Work performed 6 feet to less than 15 feet from the roof edge; and
- Work performed 15 feet or more from the roof edge.

Work performed less than 6 feet from the roof edge—Final paragraph (b)(13)(i), like the construction standard (§§ 1926.501(b)(10) and 1926.502(f)) requires that employers use conventional fall protection systems (*i.e.*, guardrail systems, safety net systems, personal fall protection systems) when they work less than 6 feet from the edge of a low-slope roof. OSHA believes that using a conventional fall protection system is necessary to protect workers from falling when they work that close to the roof edge, including the edge of low-slope roofs. Without conventional fall protection, an inadvertent slip or trip this close to the edge could propel the worker off the roof.

Work performed 6 feet to less than 15 feet from the roof edge—Final paragraph (b)(13)(ii), which applies when employees work at least 6 feet but less than 15 feet from the roof edge, requires that employers protect workers from falling by using:

- A conventional fall protection system; or
- A designated area, but only when the employer is performing work “that is both infrequent and temporary.”

The final rule defines “designated area” as “a distinct portion of a walking-working surface delineated by a warning line in which employees may perform work without additional fall protection” (final § 1910.21(b)). The definition of designated area is similar to the construction standard’s “warning line system,” defined as a barrier erected on a roof to warn employees that they are approaching an unprotected roof side or edge, and which designates an area in which roofing work may take place without the use of guardrail, body belt, or safety net systems to protect employees in that area (§ 1926.500(b)).

In the preamble to the construction fall protection standard, OSHA explained how warning line systems work:

⁶⁰OSHA notes that final paragraph (b)(13) only applies to unprotected “edges” of low-slope roofs. As such, employers must protect workers from holes on roofs, including skylights, in accordance with final paragraph (b)(3).

[A] warning line “serves to warn and remind employees that they are approaching or working near a fall hazard by providing direct physical contact with the employee. The contact attracts the employee’s attention, enabling the employee to stop in time to avoid falling off the roof” (59 FR 40672, 40689 (8/9/1994)).

OSHA intends the use of designated areas and warning lines in the final rule to work in the same way.

The use of designated areas in the final rule is very limited. Final paragraph (b)(13)(ii), like the construction standard, only allows employers to use designated areas for work performed at least six feet from the roof edge. When work that is at least 6 feet from the edge of a low-slope roof, OSHA believes the use of fall protection alternatives is appropriate in certain situations. As far back as the 1990 proposed rule, OSHA said that working a “six foot (1.8m) distance [from the edge of a low-slope roof] is sufficient to allow an employee to stop moving toward the fall hazard after realizing the perimeter has been contacted” (55 FR 13360, 13376 (4/10/1990)).

That said, working as close as 6 feet from the edge of a roof, even a low-slope roof, may pose some risk of falling. To address that risk, the final rule further limits the use of designated areas at that distance to work that is “both infrequent and temporary” (final § 1910.28(b)(13)(ii)). The proposed rule limited designated areas to work “of a temporary nature” (proposed § 1910.29(d)(1)(ii)). In the preamble to the proposed rule, OSHA said, “Designated areas may only be used for temporary, relatively infrequent work” (75 FR 28895). OSHA believes the language in the final rule more clearly expresses OSHA’s proposed intent.

For purposes of the final rule, “temporary” means that the duration of the task the worker performs is brief or short. Temporary and brief or short tasks generally include those that a worker is able to perform in less time than it takes to install or set up conventional fall protection. When the duration of a task is this short and the work is performed at least 6 feet from the edge of a low-slope roof, OSHA believes worker exposure to fall hazards is very limited. OSHA agrees with stakeholders who said that requiring employers to install conventional fall protection in these instances could increase worker exposure substantially (e.g., Exs. 165). Conversely, when it takes more time to complete a job than it takes to install or set up conventional fall protection (e.g., personal fall protection system), OSHA believes that the use of conventional fall protection is

necessary because the duration of and potential for exposure to fall hazards is more significant; such exposure is extensive and prolonged.

Temporary tasks also include those that workers are able to complete at one time rather than repeatedly climbing up or returning to the roof or requiring more than one workshift to complete. When jobs take that long to complete or involve repeated exposure, OSHA believes the risk of falls increases significantly. For purposes of the final rule, OSHA intends that “temporary” tasks generally are limited to “simple” tasks and “short-term . . . scheduled maintenance or minor repair activities” (Ex. 165). OSHA agrees with SMACNA’s comment that temporary and simple tasks are those that do not require “significant equipment, personnel, and other resources” or a level of exposure that “long-term” or “complicated” maintenance and repair work does (Ex. 165).

Although the final rule does not place a specific time limit on what constitutes a temporary task, OSHA agrees with SMACNA that short duration tasks generally are those that take less than “1–2 hours” to complete (Ex. 165; see also Exs. 124; 171; 236). Examples of temporary tasks include changing a filter in a roof-top HVAC system, replacing a part on a satellite dish, caulking or resealing the flashing around a skylight, or sweeping a chimney.

The term “infrequent,” for purposes of the final rule, means that the task or job is performed only on occasion, when needed (e.g., equipment breakdown), on an occasional basis, or at sporadic or irregular intervals. Infrequent tasks include work activities such as annual maintenance or servicing of equipment, monthly or quarterly replacement of batteries or HVAC filters, and responding to equipment outage or breakdown. In these instances, the frequency of exposure to fall hazards is very limited.

By contrast, tasks performed or repeated on a daily, routine or regular basis are not infrequent activities within the meaning of the final rule. Infrequent jobs also do not include those that workers perform as a primary or routine part of their job or repeatedly at various locations during a workshift. A task may be considered infrequent when it is performed once a month, once a year, or when needed.

The designated area provision in final paragraph (b)(13)(ii) generally is modelled on the construction fall protection standard, which allows employers to use “warning line systems” when they perform roofing

work at least six feet from the edge of a low-slope roof (§ 1926.501(b)(10)). However, the final rule also differs from the construction standard in several respects. The construction provision is limited to “roofing work,” which that standard defines as “the hoisting, storage, application, and removal of roofing equipment and materials, including related insulation, sheet metal and vapor barrier work, but not the construction of roof decks” (§§ 1926.500(b)). Roofing jobs typically take a significant amount of time to complete (hours or days). As a result, workers have prolonged exposure to fall hazards. Therefore, the construction standard requires that employers performing roofing work as close as 6 feet from the roof edge must use conventional fall protection systems, warning line systems used in combination with conventional fall protection, or warning line systems in combination with safety monitoring systems. The construction standard included alternative fall protection options for roofing work because the “Agency recognized [conventional fall protection] systems could pose feasibility problems during roofing work; therefore, the rule allows other choices of fall protection methods” (Letter to Mr. Anthony O’Dea (12/15/2003); 59 FR 40688–89).⁶¹ Some stakeholders said the same feasibility issues are present in general industry (Exs. 192; 226; 236). Southern Company, for instance, said there are no suitable anchorage points for securing personal fall protection systems on some roofs (Ex. 192).

OSHA is including the designated area provision in final paragraph (b)(13)(ii) for work that is both temporary and infrequent primarily for other reasons. First, as mentioned, adding the designated area provision for work on low-slope roofs makes the final rule more consistent with the construction fall protection standard, which is one of the main goals of this rulemaking. In addition, making the general industry and construction standards more consistent will make compliance easier for employers who perform both general industry and construction activities. Many stakeholders supported including the designated area provision for this reason (e.g., Exs. 121; 124; 164; 165; 171; 180; 189; 192; 195; 207; 226; 236; 251; 254).

Second, when the slope of the roof is low, workers are at least 6 feet from the

⁶¹ OSHA letter to Mr. O’Dea available at: http://www.osha.gov/pls/oshaweb/owadisp.show_document?p_table=INTERPRETATIONS&p_id=24682.

roof edge, and their time in the area is both brief and infrequent, OSHA believes there is very limited exposure to fall hazards. As far back as the 1990 proposed rule, OSHA said “it would be unreasonable to require employers to install guardrail systems in a designated area” (55 FR 13375).

Third, when the duration of the task is very short, OSHA believes the physical reminder that warning lines provide can effectively alert and remind workers that they are approaching the roof edge and must not get any closer. Fourth, OSHA agrees with stakeholders that requiring employers to spend the time installing conventional fall protection in instances when the task is brief and infrequent may pose a greater risk of falling than the task itself (Exs. 124; 165; 171).

Fifth, allowing employers to use designated areas instead of conventional fall protection when they perform tasks that require less time to complete than installing conventional fall protection significantly limits the duration of the job, thereby increasing efficiency and cost-effectiveness. Allowing employers to use designated areas reduces the cost of the job and also makes it easier for them to assign one-person jobs, which a number of stakeholders do (e.g., Exs. 150; 165).

Finally, the final rule allows the use of designated areas only in very limited situations. The proposed rule would have allowed greater use of designated areas. OSHA believes that the limitations incorporated in final paragraph (b)(13)(ii) (i.e., work that is performed on low-slope roofs, that is performed at least 6 feet from the edge and that is both temporary and infrequent) ensures that designated areas are used only where the duration and frequency of exposure is extremely limited. In these situations, OSHA believes that the use of designated areas provides adequate protection and does not compromise worker safety.

OSHA believes the designated area provision in the final rule also is more protective than the construction standard. As mentioned, the construction standard allows employers to use warning line systems in combination with a safety monitoring system when performing roofing work (i.e., work that involves prolonged exposure to fall hazards) 6 feet or more from the roof edge (§ 1926.501(b)(10)). The construction standard does not limit the use of warning line systems to work that is both temporary and infrequent. It also does not require employers to demonstrate that all conventional fall protection systems are infeasible in order to use a safety

monitoring system. By contrast, the final rule does not permit employers to use safety monitoring systems unless the employer first demonstrates that all conventional fall protection systems are infeasible.

OSHA notes that some commenters (Exs. 124; 165; 171) opposed requiring employers to establish designated areas (i.e., erect warning lines) for short duration jobs performed within 15 feet from the roof edge could (Ex. 171). Some stakeholders supported excepting work that is both temporary and infrequent from the requirement to use warning lines for work performed 6 feet to less than 15 feet from the roof edge (Exs. 165; 207). For example, SMACNA said:

Where is the hazard if the HVAC work does not require the worker to be within 15 feet of the roof edge . . . and the worker is only on the roof for a specific purpose (repair or maintain equipment) and for a short time . . . ? (Ex. 165).

OSHA disagrees with SMACNA. When employers perform any work, including work that is both temporary and infrequent in nature, as close as 6 feet from the edge of a low-slope roof, the Agency believes that some protection is necessary because there is or may be some risk of falling.

SBA Office of Advocacy said requiring employers to erect warning lines for short duration tasks could “present an independent hazard” (Ex. 124). They reported, “[Small business representatives] expressed concern about situations where employees are working on rooftops during simple, short-duration projects and would be required to construct physical barriers as ‘Designated Areas’ that may actually increase the risk of falls and introduce other safety hazards” (Ex. 124; see also Ex. 171).

OSHA’s experience with warning line systems in the construction industry does not support SBA Office of Advocacy’s claim that using designated areas for brief tasks poses a greater hazard and the commenter did not provide any evidence to support their claim. Moreover, SBA Office of Advocacy recommended that OSHA make the final rule consistent with the construction fall protection standard, which, as mentioned, does not exempt “short duration projects” from providing any fall protection (conventional or designated areas) at this distance from the edge of low-slope roofs the requirements to provide fall protection. That said, OSHA believes the allowances that final paragraphs (b)(13)(ii) and (iii) include for employers who perform work that is both

infrequent and temporary, provides substantial flexibility and should not pose any significant compliance difficulties.

Work performed 15 feet or more from the roof edge—Final paragraph (b)(13)(iii), which applies to work performed 15 feet or more from the edge of a low-slope roof, requires that employers protect workers from falling by:

- Using a conventional fall protection system or a designated area. If, however, the work is both infrequent and temporary, employers do not have to provide any fall protection (final paragraph (b)(13)(iii)(A)); and

- Implementing and enforcing a work rule prohibiting employees from going within 15 feet of the roof edge without using fall protection in accordance with final paragraphs (b)(13)(i) and (ii) (final paragraph (b)(13)(iii)(B)).

Final paragraph (b)(13)(iii) generally is consistent with OSHA’s longstanding enforcement policy regarding construction work performed at least 15 feet from the edge of low-slope roofs (see e.g., letter to Mr. Anthony O’Dea (12/15/2003);⁶² letter to Mr. Keith Harkins (11/15/2002);⁶³ letter to Mr. Barry Cole (5/12/2000)⁶⁴). OSHA set forth its policy in the letter to Mr. Barry Cole:

At 15 feet from the edge [of a roof] . . . , a warning line, combined with effective work rules, can be expected to prevent workers from going past the line and approaching the edge. Also, at that distance, the failure of a barrier to restrain a worker from unintentionally crossing it would not place the worker in immediate risk of falling off the edge. Therefore, we will apply a *de minimus* policy for non-conforming guardrails 15 or more feet from the edge under certain circumstances. Specifically, we will consider the use of certain barriers that fail to meet the criteria falling-object a guardrail a *de minimus* violation of the guardrail criteria in § 1926.502(b) where all of the following are met:

1. A warning line is used 15 feet or more from the edge;
2. The warning line meets or exceeds the requirements in § 1926.502(f)(2);
3. No work or work-related activity is to take place in the area between the warning line and . . . the edge;
4. The employer effectively implements a work rule prohibiting the employees from going past the warning line.

⁶² OSHA letter to Mr. O’Dea available at: http://www.osha.gov/pls/oshaweb/owadisp.show_document?p_table=INTERPRETATIONS&p_id=24682.

⁶³ OSHA letter to Mr. Harkins available at: https://www.osha.gov/pls/oshaweb/owadisp.show_document?p_table=INTERPRETATIONS&p_id=24552.

⁶⁴ OSHA letter to Mr. Cole available at: https://www.osha.gov/pls/oshaweb/owadisp.show_document?p_table=INTERPRETATIONS&p_id=24802.

In one respect, final paragraph (b)(13)(iii) differs from and provides more flexibility than the construction enforcement policy. When employers perform work that is both temporary and infrequent at least 15 feet from the roof edge, the final rule does not require them to provide any fall protection (using conventional fall protection or warning lines). OSHA believes this limited exception eases compliance for employers without compromising worker safety.

Comments in the record support an exception for work that is temporary and infrequent and performed at least 15 feet from the roof edge (Exs. 165; 207). For example, SMACNA said:

[A] work procedure such as a simple filter change or belt adjustment to an HVAC system, especially if the unit is in the middle of a large roof does not warrant placement of a physical warning line (Ex. 165).

EEI noted, "Some flat roofs in general industry settings could be the size of several football fields" (Ex. 207). OSHA agrees that requiring employers to erect a warning line in that situation could take more time than simply performing a very brief task.

Many stakeholders supported the use of the use of designated areas "where work is performed away from the immediate fall hazard, such as in the center of the rooftop" (Ex. 180; *see also* Exs. 171; 207; 226). Verallia concurred, noting that less is needed to protect or warn workers the further the work area is from the roof edge (Ex. 171). EEI also said conventional fall protection was not necessary when workers are not near the roof edge, "OSHA should not require protection from fall hazards on large flat roofs when the hazard can be controlled by keeping all workers a specified distance away from the roof edge" (Ex. 207). AFSCME agreed, saying that air-handling systems and other equipment often are located in the middle of the roof (Ex. 226).

Other stakeholders, however, said OSHA should not require any fall protection, including a warning line, for any task performed "a safe distance" from the edge of a low-slope roof (Exs. 165; 207; 236; 254). For example, MCAA, whose member companies construct, install, and service mechanical systems (*e.g.*, HVAC systems), said:

Most of the time, [HVAC] units are a safe distance from the edge of the roof and/or skylights, and can be accessed and serviced safely without the use of a "designated area" or other fall protection/prevention systems. Under this proposed rule . . . HVAC technicians would have to erect a temporary, designated area perimeter line to comply with the standard. MCAA believes that this

requirement would create unintended hazards, which would be much more likely to cause injury or death to workers (Ex. 236).

MCAA's argument is not persuasive. MCAA did not provide any data or other information to support its claim that requiring employers to erect a warning would be more likely to cause injury or death than working without any protection. Moreover, MCAA recommended that OSHA make the final rule consistent with the low-slope roof provision in the construction standard. That provision requires employers to use designated area perimeter lines for all roofing work if the employer does not use conventional fall protection.

In conclusion, OSHA believes that the limitations on the use of designated areas in final paragraphs (b)(13)(i), (ii) and (iii), taken together, provide appropriate protection from fall hazards while affording employers greater control flexibility.

Slaughtering facility platforms. Final paragraph (b)(14) specifies new requirements OSHA added to the final rule addressing fall protection for work performed on the unprotected working side of platforms in slaughtering facilities. As mentioned in the discussion of final paragraph (b)(1)(ii) earlier in this preamble, the working side is the side of the platform where workers are in the process of performing a work operation.

Final paragraph (b)(14)(i) requires that employers protect workers from falling off the unprotected working side of slaughtering facility platforms that are four feet or more above a lower level. Employers must protect those workers by providing:

- A guardrail system (final paragraph (b)(14)(i)(A)); or
- A travel restraint system (final paragraph (b)(14)(i)(B)).

The proposed rule in § 1910.28 addressed slaughtering facility platforms, as well as the working sides of loading racks, loading docks, and teeming platforms, in paragraph (b)(1). Proposed paragraph (b)(1)(vi) required that employers provide guardrail systems on the working side of slaughtering house platforms unless they could demonstrate that providing guardrail systems was infeasible. If an employer could demonstrate infeasibility, workers could work on the working side of these platforms without guardrails or any other fall protection when: the work operation on the working side is in progress (see proposed paragraph (b)(1)(vi)(A)); the employer restricts access to the platform to authorized workers (proposed paragraph (b)(1)(vi)(B)); and the employer trained the authorized

workers in accordance with proposed § 1910.30(b)(1)(vi)(C).

OSHA proposed the exception for the working sides of these platforms because information available to the Agency at the time indicated that there may be technological feasibility issues with using guardrail systems while workers are working on certain platforms. OSHA requested comment on this issue, including whether there are other feasible means to protect workers working on the unprotected side of platforms (see 75 FR 28889).

Commenters said employers often use travel restraint systems on the working side of slaughtering facility platforms, and, therefore, OSHA should not provide an exception. For example, Damon, Inc., said, "I have worked with several packing houses that have successfully implemented restraint systems" (Ex. 251). Likewise, the representative of the United Food and Commercial Workers Union (UFCW) commented:

My gravest concern is with 1910.28(b)(vi), specifically OSHA's proposed exception to the requirement for guardrails or other fall protection on the working side of platforms in slaughtering facilities. This exception is inappropriate and not protective of the thousands of workers who would be affected. Work platforms in the meatpacking industry are becoming increasingly common and are built to greater heights. Many employers, including Cargill Meat Solutions in Dodge City, KS have successfully implemented travel restraint systems for use on these platforms. Just as there is no question about the feasibility of these systems, there should be no question about the compelling need for them. There is a compelling need in meatpacking plants. Falls from platforms in slaughtering facilities are especially dangerous because of the universal use of knives and other sharp instruments (Ex. 159).

These comments and other information in the record convince OSHA that using fall protection on the working side of slaughtering facility platforms is feasible. Therefore, to eliminate any confusion, OSHA decided to specify fall protection requirements for slaughtering facility platforms in a separate provision in the final rule.

Final paragraph (b)(14)(ii) specifies that when the employer can demonstrate it is infeasible to use guardrail or travel restraint systems, they can perform the work on slaughtering facility platforms without a guardrail or travel restraint system, provided:

- The work operation for which fall protection is infeasible is in process (final paragraph (b)(14)(ii)(A));
- The employer restricts access to the platform to authorized workers (final paragraph (b)(14)(ii)(B)); and

• The employer ensures authorized workers receive training in accordance with final § 1910.30 (final paragraph (b)(14)(ii)(C)).

The language in final paragraph (b)(14)(ii) is the same as the language in the exception for working sides of loading rack, loading dock, and teeming platforms (final paragraph (b)(1)(ii)).

Walking-working surfaces not otherwise addressed. Final paragraph (b)(15), like proposed paragraph (b)(13), applies to walking-working surfaces that other paragraphs in final § 1910.28(b) do not address specifically, such as ramps. Final paragraph (b)(15), like final paragraph (b)(1), requires that employers must protect each worker on a walking-working surface not addressed elsewhere in final paragraph (b) or other subparts in 29 CFR part 1910 from falling four feet or more to a lower level using:

- Guardrail systems (final paragraph (b)(15)(i));
- Safety net systems (final paragraph (b)(15)(ii)); or
- Personal fall protection systems, such as personal fall arrest systems, travel restraint systems, and positioning systems (final paragraph (b)(15)(iii)).

Final paragraph (b)(15) does not retain the proposed fall protection measure of designated areas (proposed paragraph (b)(13)(ii)). However, final paragraph (b)(15) still gives employers the same level of control flexibility that proposed and final paragraph (b)(1)(i) provides for all unprotected sides and edges. The final rule also is consistent with the construction fall protection standard (§ 1926.501(b)(15)).

OSHA included this provision in the final rule to protect workers from all fall hazards in general industry regardless of whether final paragraph (b) in this section specifically mentions the particular walking-working surface or fall hazard. Therefore, this provision ensures that general industry employers will protect their workers from falling whenever and wherever a fall hazard is present in their workplaces. OSHA did not receive any comments on the proposed provisions and adopts it as discussed.

Paragraph (c)—Protection From Falling Objects

Final paragraph (c), like the proposed rule, requires that employers protect workers from being struck by falling objects, such as objects falling through holes or off the sides or edges of walking-working surfaces onto workers below. When workers are at risk of being struck by falling objects, the final rule requires that employers ensure that workers wear head protection meeting

the requirements of 29 CFR part 1910, subpart I. In addition, final paragraph (c) requires that employers protect workers using one or more of the following:

- Erecting toeboards, screens, or guardrail systems to prevent objects from falling to a lower level (final paragraph (c)(1));
- Erecting canopy structures and keeping potential falling objects far enough from an edge, hole, or opening to prevent them from falling to a lower level (final paragraph (c)(2)); or
- Barricading the area into which objects could fall, prohibiting workers from entering the barricaded area, and keeping objects far enough from the edge or opening to prevent them from falling to the lower level (final paragraph (c)(3)).

Final paragraph (c) simplifies the rule by consolidating into a single paragraph all of the provisions that address falling objects in the existing standard (§ 1910.23(b)(5) and (c)(1)) and the proposed rule (paragraphs (b)(3)(iii), (b)(5)(i), (b)(14)(ii)). The final rule is consistent with the proposal and patterned on the construction standard (§ 1926.501(c)). OSHA did not receive any comments on the proposed protection from falling object requirements and adopts final paragraph (c) as discussed.

Section 1910.29—Fall Protection Systems and Falling Object Protection—Criteria and Practices

Final § 1910.29, like the proposed rule, establishes system criteria and work-practice requirements for fall protection systems and falling object protection specified by final § 1910.28, Duty to have fall protection systems and falling object protection,⁶⁵ and § 1910.140, Personal fall protection equipment.

As discussed earlier in this preamble, final §§ 1910.28, 1910.29, 1910.30, and 1910.140 establish new provisions that provide a comprehensive approach to fall and falling object protection in general industry. Final § 1910.28 specifies that employers must provide fall and falling object protection for workers exposed to fall and falling object hazards, and select a system that the final rule allows them to use in particular situations or operations.

⁶⁵ The final rule revised the title for § 1910.29 to state that it establishes criteria and practices for both fall protection systems and falling object protection. Although the proposed title only listed fall protection systems, it also included criteria and systems for protecting workers from falling objects. OSHA believes stakeholders understood the proposed rule covered both fall protection systems and falling object protection, the final rule makes it clear and explicit.

Final § 1910.29 requires that employers ensure the fall protection system and falling object protection they select meet the specified criteria and practice provisions. Finally, § 1910.30 requires that employers ensure workers exposed to fall and falling object hazards and who must use fall protection systems and falling object protection receive training on those hazards and how to use the required protection properly. OSHA notes that the final rule adds a requirement that employers provide training for personal fall protection systems to existing § 1910.132.

In general, OSHA patterned the system criteria and work practice requirements in final § 1910.29 to be consistent with its construction standards (§§ 1926.502 and 1926.1053). OSHA believes that making the general industry fall protection system and falling object protection criteria requirements consistent with the construction standards will make the final rule easier to understand than the existing general industry standard, and make compliance easier for employers who perform both general industry and construction activities. In many situations employers should be able to use the same fall protection systems and falling object protection for both activities, which helps to minimize compliance costs. As mentioned in the preamble to final § 1910.28, many commenters supported making the general industry fall and falling object protection requirements consistent with those in the construction industry.

Final § 1910.29, like the proposed rule, reorganizes the existing rule so that the format of the final rule is consistent with the format in the construction fall protection standard in § 1926.502. OSHA believes this reorganization will make the final rule easier to understand and follow because many employers already are familiar with and follow the construction requirements.

Final § 1910.29 also draws provisions from, and is consistent with, national consensus standards addressing personal fall protection systems and falling object protection, including:

- ANSI/ASC A14.3–2008, American National Standards for Ladders—Fixed (A14.3–2008) (Ex. 8);
- ANSI/ASSE A1264.1–2007, Safety Requirements for Workplace Walking/Working Surfaces and Their Access; Workplace, Floor, Wall and Roof Openings; Stairs and Guardrails Systems (A1264.1–2007) (Ex. 13); and
- ANSI/ASSE A10.18–2012, Safety Requirements for Temporary Roof and Floor Holes, Wall Openings, Stairways, and Other Unprotected Edges in

Construction and Demolition Operations (A10.18–2012) (Ex. 388); and

- National Fire Protection Association (NFPA) 101–2012, Life Safety Code (NFPA 101–2012) (Ex. 385).

Paragraph (a)—General Requirements

Final paragraph (a) establishes general requirements that are applicable to the fall protection systems and falling object protection covered by final 29 CFR part 1910.

In final paragraph (a)(1), OSHA specifies that employers ensure all fall protection systems and falling object protection that 29 CFR part 1910 requires meet the requirements in § 1910.29. Accordingly, the requirements of § 1910.29 apply to fall protection systems and falling object protection that other part 1910 standards require if those standards do not establish specific criteria and work practices. For example, final paragraph (a)(1) requires that ladder safety systems on fixed ladders used at sawmills (§ 1910.265) must comply with requirements in § 1910.29(i) because § 1910.265 does not specify criteria that ladder safety systems must meet.

When employers elect to use a personal fall protection system, final paragraph (a)(1) specifies that employers must ensure those systems meet the applicable requirements in 29 CFR part 1910, subpart I, namely final §§ 1910.132, General requirements, and 1910.140, Personal fall protection equipment. Final § 1910.140 establishes personal fall protection system criteria and work practice requirements, while § 1910.132 establishes provisions that apply to all personal protective equipment (PPE), including personal fall protection systems. For example, § 1910.132(a) requires that employers provide, use, and maintain PPE, including personal fall protection systems, in a reliable condition, and § 1910.132(c) specifies that employers ensure that the design and construction of PPE is safe for the work the employee is performing. In addition, § 1910.132(d) requires that employers perform a hazard assessment and “[s]elect PPE that properly fits each affected employee,” while § 1910.132(h) requires, with a few exceptions, that employers must provide PPE, including personal fall protection systems, at no cost to the worker.

Final paragraph (a)(1) revises the proposed rule slightly by deleting the reference to “body belts and body harnesses,” because they are components of personal fall protection systems. OSHA did not receive any comments on proposed paragraph (a)(1)

and adopts the provision with the change discussed.

Final paragraph (a)(2) specifies that employers must provide and install all fall protection systems and falling object protection required by final subpart D, and comply with all other applicable requirements of final subpart D, before any worker begins work that necessitates fall or falling object protection. Final paragraph (a)(2), requires that employers take a proactive approach to managing fall and falling object hazards by installing, for example, fall protection systems or components (e.g., a vertical lifeline), so the systems are in place and available for use whenever there is potential worker exposure to fall hazards. OSHA believes that a proactive approach will encourage employers to anticipate and evaluate whether their workers may be on walking-working surfaces where a potential fall or falling object hazard exists and install systems (e.g., guardrail systems, toeboards) or attachment (tie-off) points (e.g., anchorages, tieback anchors) so that workers can use such protection readily when needed.

OSHA believes such proactive planning and action already are part of the standard operating procedures for many employers. OSHA also believes that such pre-planning will encourage and guide employers to use the most effective and protective measures to address fall and falling object hazards. OSHA did not receive any comments on proposed paragraph (a)(2) and adopts the provision with the clarification discussed above.

Paragraph (b)—Guardrail Systems

Final paragraph (b) contains system requirements employers must follow to ensure guardrail systems they use will protect workers from falling to lower levels. In developing final paragraph (b), OSHA carried forward, with some revision, many of the requirements from the existing rule (e.g., existing § 1910.23), and also drew the requirements from the construction fall protection standard in § 1926.502(b).

The Agency believes that the revised guardrail requirements make the final rule easier to understand than the existing general industry rule, reflect current technology and work practices, and ensure consistency among guardrail requirements throughout general industry. For example, OSHA reorganized the final rule so the same guardrail system requirements (final paragraph (b)) apply uniformly to all walking-working surfaces, in turn making the requirement easier to understand than the existing general industry rule, which separately lists the

guardrail requirements for floor holes, open-sided floors, platforms, runways, and stairways. In addition to the explanations below for each of the guardrail system requirements, OSHA notes that the preamble to § 1926.502 (59 FR 40733) also provides useful explanatory material for each of the guardrail system provisions in § 1926.502(b).

Final paragraph (b)(1) specifies requirements for the minimum and maximum height of guardrail systems. Final paragraph (b)(1) carries forward the existing requirement (existing § 1910.23(e)(1)) that employers must ensure the top edge of the top rails of guardrail systems is 42 inches above the walking-working surface, which is consistent with the proposal and the construction fall protection standard (§ 1926.502(b)(1)). The final rule allows the height of guardrails to deviate from the 42-inch required height by up to three inches, plus or minus, which also is consistent with the construction standard. Final paragraph (b)(1) clarifies in objective terms (“plus or minus 3 inches”) the language in the existing provision that the guardrail height may deviate from 42 inches by a “nominal” amount. OSHA believes that a deviation of no more than three inches from the 42-inch guardrail height constitutes a “nominal” deviation that will not compromise worker protection. The Agency believes that continuing this allowance provides flexibility for employers if they make changes to walking-working surfaces (e.g., adding carpet, installing grating, and replacing flooring) that may slightly reduce the effective height of the guardrail (see 55 FR 13374).

Final paragraph (b)(1) also is consistent with A10.18–2012 (Section 4.1.2) and A1264.1–2007 (Section 5.4). A1264.1–2007 (Section 5.4) requires that guardrails have a minimum height of 42 inches, but does not specify a maximum height. A note to that standard explains that, generally, “guardrails are 42 to 45 inches in height” (Section E5.4).

Final paragraph (b)(1) also revises the existing rule (existing § 1910.23(e)(1)) to allow employers to erect guardrail systems that exceed the 45-inch height limit, provided the employer ensures that the higher guardrails comply with all other requirements in paragraph (b). The final rule is consistent with the requirement in the construction fall protection standard (§ 1926.502(b)(1)), which permits an increase in the top rail height “when conditions warrant.” OSHA believes that such conditions also exist in general industry, and that exceeding the 42-inch height

requirement will not impact worker safety as long as employers comply with the other provisions of final paragraph (b). While the proposed rule allowed higher guardrail systems in these situations “when conditions warrant,” OSHA did not adopt that phrase in the final rule because the Agency concluded that no other conditions are necessary to ensure employee safety as long as the employer satisfies the other provisions of final paragraph (b). OSHA believes that adding this exception to the final rule will make compliance easier for employers who perform both general industry and construction activities. Neither the A10.18–2012 nor the A1264.1–2007 standards include this exception to the guardrail height limit. Ameren supported “relaxing the ‘maximum’” height requirement for the reasons OSHA delineated (Ex. 189).

In the preamble to the proposed rule, OSHA said it was considering adding a provision that would allow employers to use barriers “as the functional equivalent of guardrails” (75 FR 28894). Such a provision would permit employers to use barriers as guardrails even if the height of the barriers is as low as 30 inches provided the total sum of the height and depth of the barrier is 48 inches. Using this formula, an employer could use a barrier with a height of 36 inches if the depth of the barrier were at least 12 inches. OSHA notes that the 1990 proposal, which the Agency did not adopt, included the provision as an alternative means of complying with the 42-inch guardrail height requirement (55 FR 13374). The preamble to the 1990 proposal explained that the National Bureau of Standards recommended a formula from its 1976 report, “A Model Performance Standard for Guardrails.”

OSHA received one comment about the potential provision. Thomas Kramer, of LJB, Inc., supported incorporating the provision in the final rule, stating, “This reference would allow a number of parapets associated with roof fall hazards to be used as a compliant physical barrier. It would have the added value of providing the building owner with a very low cost, if any cost at all, solution to protecting workers on a roof,” and further commenting that “[c]learly, this proposed revision is technologically feasible” (Ex. 367).

For the following reasons, OSHA decided not to add a provision allowing the use of barriers as functional equivalents of guardrail systems. First, incorporating the provision would make the final rule inconsistent with the construction fall protection standard, which is contrary to a major goal of the rulemaking. Similarly, neither A10.18–

2012 nor the A1264.1–2007 include the provision.

Second, the formula from the 1976 report “A Model Performance Standard for Guardrails,” which forms the basis for the potential provision, is almost 40 years old. The documents and codes the report references are even older. OSHA believes that industry practices over the last 40 years overwhelmingly complied with the 42-inch guardrail requirement in the existing rule as well as the construction fall protection and ANSI standards, eliminating the need for this alternative.

Finally, OSHA does not believe the provision will provide fall protection that is as effective as the final rule. The Agency believes there is a risk of workers falling over barriers that are one-half foot or more lower than the required 42-inch guardrail height. In particular, OSHA does not believe a barrier with a height of 36 inches provides adequate protection from falls even when the barrier depth is 12 inches. OSHA believes it would be too easy for workers to fall over barriers that are one-half foot lower than the required height, and that the 12-inch barrier depth would not provide adequate protection from going over the barrier. OSHA expressed much the same rationale when it decided not to propose a provision that would allow existing guardrails that are 36 inches in height. In the proposed rule OSHA said that it did not consider 36-inch high guardrails to be as safe as the required 42-inch high guardrails (75 FR 28894).

OSHA notes that the 1990 proposed rule would have allowed a 36-inch minimum height for existing guardrail systems instead of the required 42 inches (55 FR 13360 (4/10/1990)). In particular, the earlier proposal would have codified the 1981 OSHA directive classifying as a *de minimus* violation any existing guardrail having a height of 36 inches (STD 01–01–010). OSHA issued the directive because it recognized that employers likely erected guardrails under pre-OSHA building codes (55 FR 13373). As mentioned, however, OSHA did not propose allowing this alternative in the 2010 proposal because of safety concerns. In addition, due to those concerns, OSHA also announced that it was going to rescind the directive and previous interpretations treating 36-inch height guardrails as *de minimus* violations (see 75 FR 28894 n.2).

OSHA received several comments recommending that the Agency not rescind the directive and instead adopt a provision allowing employers to continue using existing guardrails that have a height of 36 inches. Mercer ORC

questioned OSHA’s statement in the proposal that guardrails 36 inches in height are not as “equally safe” as guardrails with a height of 42 inches (Ex. 254). However, they provided no evidence to support deviating from the height requirements in the construction fall protection standard and both A10.18–2012 and A1264.1–2007. Mercer ORC also said OSHA should estimate the costs associated with replacing the lower-height guardrails and the number of injuries prevented by having guardrails that are 39 inches in height (Ex. 254). Mercer ORC stated:

Clearly, if people have been writing to OSHA to ask about guardrails that are less than the “42 inches nominal” in the existing rule, there are likely to be significant numbers of workplaces that have these non-standard guardrails in place. OSHA should either quantify the benefits and costs of this rule change or grandfather those guardrail installations that occurred prior to the effect date of the new rules (Ex. 254).

The New York City Department of Environmental Protection (NYCDEP) commented that requiring 42-inch guardrails would “impact” many NYCDEP facilities (Ex. 191). They said the 42-inch height requirement “will not provide a benefit to our employees commensurate with the costs and will encumber funds that could be used for more efficacious health and safety initiatives.”

OSHA does not agree with Mercer ORC and NYCDEP that requiring guardrails to be 42 inches in height will impose significant costs to a substantial number of workplaces. They did not provide any evidence showing that a 36-inch guardrail height better effectuates the purposes of the OSH Act than the proposed 42-inch height. In fact, the requirement that employers ensure guardrails be 42 inches high (plus or minus 3 inches) has been in place since OSHA adopted the Walking-Working Surfaces standards in 1972 from then-existing national consensus standards (ANSI A12.1–1967, Section 7.1) (38 FR 24300 (9/6/1973)). Moreover, the guardrail height requirements in those consensus standards were adopted years before 1972. A1264.1–2007 and A10.18–2012 also require that guardrail heights be at least 42 inches.

OSHA points out the directive OSHA issued in 1981 allowing guardrails to have a minimum height of 36 inches instead of 42 inches only applied to guardrails existing at that time. OSHA believes that the vast majority of guardrails in use today are 42 inches (plus or minus 3 inches) in height. Therefore, OSHA does not believe that employers will experience significant difficulty bringing any remaining

guardrails into compliance with this final standard. Accordingly, the final rule does not allow existing guardrails that are less than 39 inches in height. Moreover, OSHA hereby rescinds OSHA Directive STD 01–01–010 and all subsequent letters of interpretation allowing guardrails to have a minimum height of 36 inches.

Mr. M. Anderson raised a different point regarding the 42-inch guardrail height requirement, saying that the requirement will pose a problem for historic buildings, which often have low guardrails:

This will present an infeasible-to-fix problem for historic sites. Many historic balustrades are less than the required 42 [inches]. In order to comply with this height requirement, balustrades will have to be replaced thereby changing the historic aesthetic of the building. This seems to go against the Historic Preservation Act (Ex. 139).

OSHA did not receive comments from any other stakeholders concerning historic buildings and historic preservation requirements. To the extent that any employer encounters such a problem, the employer may use one of the other means of fall protection authorized by § 1910.28 (e.g., safety net systems or personal fall protection systems).

Final paragraph (b)(2), like the proposed rule, requires that employers install intermediate protective members, such as midrails, screens, mesh, intermediate vertical members, solid panels, or equivalent intermediate members between the walking-working surface and the top edge of the guardrail system when there is not a wall or parapet that is at least 21 inches (53 cm) high. Whatever intermediate protective member employers use, the final rule requires that employers install them as follows:

- Install midrails midway between the top edge of the guardrail system and the walking-working surface. Since the final rule requires that guardrail systems be 42 inches high (plus or minus three inches), employers must install midrails approximately 21 inches above the horizontal walking-working surface (final paragraph (b)(2)(i));

- Install screens, mesh, and solid panels from the walking-working surface to the top rail and along the entire opening between top rail supports (final paragraph (b)(2)(ii));

- Install intermediate vertical members, such as balusters, no more than 19 inches apart (final paragraph (b)(2)(iii)); and

- Install other equivalent intermediate members, such as additional midrails and architectural

panels, so that openings are not more than 19 inches wide (final paragraph (b)(2)(iv)).

OSHA drew the requirements in final paragraph (b)(2) from the construction fall protection standard in § 1926.502(b)(2), which has almost identical requirements. The existing rule in § 1910.23(e)(1) and (e)(3)(v)(c) only address the installation of midrails. OSHA believes final paragraph (b)(2) provides more clarity and flexibility than the existing rule. Final paragraph (b)(2) includes examples of different types of intermediate members that employers may use, and identifies the placement/installation criteria for each type. In addition, the final rule does not require that employers install intermediate protective members when the guardrail system is on a wall or parapet that is at least 21 inches high, which is consistent with the construction fall protection standard. OSHA believes it is not necessary to install intermediate protective members where a wall or parapet reaches at least the same height as that required for a midrail.

OSHA received one comment on proposed paragraph (b)(2). Ellis Fall Safety Solutions (Ellis), recommended that guardrails made of wire cable use at least three wires so the space between cables does not exceed 19 inches (Ex. 155). OSHA does not believe it is necessary to add such language to the final rule. The requirements on “intermediate members” and “other equivalent intermediate members” include wire cables; thus, the final rule in paragraphs (b)(2)(iii) and (iv) already require that wire cable installed in a guardrail system leave no opening in the system that exceeds 19 inches.

OSHA added language to final paragraph (b)(2) to clarify that solid panels are an example of a protective intermediate member. This addition makes the final provision consistent with final paragraph (b)(5).

Final paragraphs (b)(3) and (4) are companion provisions that establish strength requirements for guardrail systems. Final paragraph (b)(3), like the proposed rule, requires that employers ensure guardrail systems are capable of withstanding, without failure, a force of at least 200 pounds applied in a downward or outward direction within two (2) inches of the top edge, at any point along the top rail. Final paragraph (b)(3) generally is consistent with the existing rule in §§ 1910.23(e)(3)(iv) and (e)(3)(v)(b). The final rule is almost identical to the construction fall protection standard in § 1926.502(b)(3), and consistent with A10.18–2012 (Section 4.1.4).

The term “failure,” as defined in final § 1910.21(b), means a load refusal (*i.e.*, the point at which the load exceeds the ultimate strength of a component or object), breakage, or separation of a component part. Conversely, “without failure” means a guardrail system must have adequate strength to withstand at least 200 pounds applied downward or outward within two inches of the top edge of top rail, without a load refusal, breakage, or separation of component parts. OSHA believes that if the guardrail system can withstand application of such force, even if the system has some minor deformation, it will be capable of preventing a worker from falling. OSHA believes minor deformation that does not affect the structural integrity or support capabilities of the guardrail system does not constitute failure as the final rule defines it.

OSHA also has removed the language in the existing standard that requires supporting posts to be spaced not more than 8 feet apart. OSHA believes the performance language of final paragraph (b)(3) is adequate, and also provides greater flexibility. In some cases an 8-foot distance between posts may not be adequate to meet the 200-pound strength requirement, while in other situations and with certain materials, the guardrail will maintain a 200-pound force with the supporting posts installed at distances greater than 8 feet apart. Employers must install supporting posts at whatever distance is necessary to meet the strength requirement of the final rule, without failure.

OSHA received two comments on proposed paragraph (b)(3). Peter Catlos recommended that the final rule, at a minimum, specify test methods or requirements for load concentrations and rates when applying the 200-pound test load (Ex. 203). Without specifying load concentrations and rates, or test methods, Mr. Catlos said the referenced 200-pound minimum load requirement “is not definitive” (Ex. 203).

Consistent with Section 6(b)(5) of the OSH Act, final paragraphs (b)(3) and (4) use a performance-based approach that establishes the strength objective employers must meet when testing a guardrail. The A10.18–2012 standard (Section 4.1.4) and the A1264.1–2007 standard (Section 5.6.1) follow a similar approach. As such, OSHA believes the strength requirement, which also is identical to the requirement in the construction fall protection standard, is protective, clear, and functional.

Final paragraph (b)(3) gives employers flexibility to use whatever test methods or manufacturer information they want so long as those methods and

specifications meet the same strength requirement as the final rule. OSHA notes that A1264.1–2007 and American Society for Testing and Materials (ASTM) E985–00e1–2006 Standard Specification for Permanent Metal Railing Systems and Rails for Buildings, provide helpful guidance for meeting the 200-pound strength requirement.

The other commenter, Ellis, recommended that OSHA revise the 200-pound strength requirement to 276 pounds (*i.e.*, the 95th percentile for men) (Ex. 155). He said that, according to the National Health and Nutrition Examination Survey, the average weight of workers increased about 1½ to 2 pounds a year since the 1950s, adding, “Heavier workers deserve to be protected and just because ANSI and OSHA have not updated their standards for effectively 40 years does not mean we should stay with out of date values” (Ex. 155). OSHA does not believe the change Ellis proposes is necessary. The 200-pound strength requirement in A10.18–2012 (Section 4.1.4) and A1264.1–2007 (Section 5.6.1) is a minimum strength requirement.

Finally, Ellis said OSHA should prohibit using guardrail systems as anchorages for personal fall protection systems unless a registered structural engineer approves, marks, or labels the systems for such use. OSHA does not believe it is necessary to add Ellis’ recommendation to the final rule because § 1910.140 requires that personal fall protection system anchorages be capable of supporting 5,000 pounds. However, final paragraph (b)(3) only requires that guardrail systems be capable of withstanding a force of at least 200 pounds, which means that guardrail systems are not capable of serving as anchorages unless they also meet the requirements anchorages in final rule § 1910.140. OSHA, received no other comments and is adopting in this final rule paragraph (b)(3) as discussed.

Final paragraph (b)(4), like the proposed rule, requires that employers ensure that when the 200-pound test load is applied in a downward direction, the top rail of the guardrail system does not deflect to a height of less than 39 inches above the walking-working surface. Deflection refers to the distance or degree a structure moves or displaces when a load is applied to the structure. To illustrate, employers must ensure that application of the required minimum test load to the top rail of a 42-inch guardrail system does not reduce its height by more than three inches. If the load or stress placed on a guardrail system, regardless of its height, reduces the height of the system

to less than 39 inches, it is not likely to be tall enough to prevent workers from falling over the top rail. Therefore, final paragraph (b)(4) specifies that employers must ensure the height of their guardrail systems, deflected or not, is never less than 39 inches high.

Final paragraph (b)(4) is almost identical to the construction fall protection standard in § 1920.502(b)(4). The A10.18–2012 standard (Section 4.1.4) specifies that guardrails shall not deflect more than 3 inches in any direction. Since that standard does not allow any nominal deviation in the guardrail height, it means that standard limits the deflected height to not less than 39 inches high.

OSHA received comments from Mr. Catlos and Ellis on proposed paragraph (b)(4). Ellis opposed allowing the guardrail system to deflect as much as 3 inches, stating, “[Three inches of] movement specified in 1926.502 is too great and 1.5 [inches] should be [the maximum] when over half the male worker [center of gravity] exceeds 39 [inches]” (Ex. 155). OSHA believes that a guardrail system that has a height of at least 39 inches, as final paragraph (b)(4) requires (*i.e.*, “42 inches, plus or minus 3 inches”), is adequate to protect a worker from falling over the top rail. OSHA drew final paragraph (b)(4) from the construction fall protection standard, and the Agency is not aware of any data indicating workers are falling over guardrail systems that have a height of at least 39 inches. OSHA also notes the final rule is consistent with A10.18–2012 (Section 4.1.4), indicating final paragraph (b)(4) has wide stakeholder acceptance.

Mr. Catlos raised concerns that the proposed language on deflection does not include a horizontal deflection allowance or limit (Ex. 203). He pointed out that proposed paragraph (b)(3) includes both vertical and horizontal load test requirements, and he said that, for consistency, final paragraph (b)(4) should include a horizontal load test and deflection allowance, in addition to the vertical allowance. OSHA disagrees with the commenter for the following reasons. First, the final rule focuses on ensuring that guardrail systems maintain a minimum height, so that if workers fall into or onto the guardrail they are protected from falling over the top rail.

Second, Mr. Catlos did not say what would constitute an appropriate horizontal load test deflection allowance and OSHA believes that allowing a horizontal deflection in addition to the vertical allowance, may result in failure of the guardrail system to protect workers from falling. For

example it may break or permanently deform in a way that affects the structural integrity of the guardrail system. Such deformation may adversely affect the structural integrity or support capabilities of the system when workers lean on or fall into the top rail of a guardrail that is not perpendicular to the horizontal walking-working surface. In this regard, Mr. Catlos did not provide any data indicating that horizontal deflection of the guardrail system would not result in system failure. Additionally, OSHA is concerned that after repeated horizontal deflection, the guardrail could be reduced in height to below 39 inches, which is below the minimum height requirement that final paragraph (b)(1) requires.

Third, OSHA believes that allowing a horizontal deflection when vertical deflection already reduces the height of guardrail systems may put workers at risk of falling over the top rail. This is true especially when vertical deflection reduces the height of the top edge of a guardrail system to 39 inches. OSHA does not believe Mr. Catlos presented a compelling argument to support deviating from the construction fall protection standard § 1926.502(b)(4) by adding a horizontal deflection allowance to final paragraph (b)(4). Therefore, OSHA is adopting in this final rule paragraph (b)(4) as discussed.

Final paragraph (b)(5), like the proposal, requires that employers ensure midrails, screens, mesh, intermediate vertical members, solid panels, and other equivalent members, are capable of withstanding, without failure, a force of at least 150 pounds applied in any downward or outward direction at any point along the intermediate member.

The existing standard does not contain a strength requirement for midrails and this omission has resulted in confusion. OSHA drew the proposed requirement from the construction fall protection standard in § 1926.502(b)(5). In the preamble to that rule, OSHA explained that a strength test of 150 pounds was adequate for intermediate structures because they do not serve the same purpose as the top rails of guardrail systems (59 FR 40672, 40697 (8/9/1994)). Workers often place forces on top rails (*e.g.*, leaning over the top rail) that they do not place on intermediate members; if workers fall onto a guardrail, they most likely will strike the top rail, not the intermediate member. Therefore, OSHA believes that midrails and other intermediate members do not need deflection limits.

The A1264.1–2007 standard (Section 5.6.1) requires that intermediate

members be capable of withstanding a slightly higher horizontal load limit (*i.e.*, 160 pounds) applied in a downward (*i.e.*, perpendicular) direction at the midpoint and mid-height. OSHA notes that A1264.1–2007 (Section 5.6.1) also includes a 3-inch horizontal deflection allowance. The A10.18–2012 standard does not include a load test for midrails and other intermediate members. Although the final rule only requires a 150-pound load test, OSHA believes, nonetheless, that the final rule is more protective than the A1264.1–2007 standard because it does not permit a 3-inch horizontal deflection allowance. OSHA did not receive any comments on the proposal and adopts it as discussed above.

Final paragraph (b)(6), like the proposed rule, requires that employers ensure guardrail systems are smooth-surfaced to protect workers from injury, such as punctures or lacerations, and to prevent catching or snagging of workers' clothing. The final rule is based on the existing requirement in § 1910.23(e)(1) and (e)(3)(v)(a), and A1264.1–2007 (Section 5.4). The final rule also is consistent with the construction fall protection standard in § 1926.502(b)(6), as well as A10.18–2012 (Section 4.1), which specifies that guardrails be free of "sharp edges, splinters, or similar conditions."

The Agency believes it is important that guardrail systems have smooth surfaces to prevent injuries. For example, workers can cut or puncture their hands or other parts of their bodies, when they grab or lean against guardrails that have protruding nails. Similarly, protruding nails can catch workers' clothing which can damage protective clothing or cause workers to trip or fall. OSHA did not receive any comments on the proposed rule and adopts it with the changes discussed above.

Final paragraph (b)(7), like the proposed rule, requires that employers ensure the ends of top rails and midrails do not overhang the terminal posts, except where the overhang does not pose a projection hazard for workers. Top and midrails that extend past the terminal post may cause a worker's clothing or tool belt to catch which could result in a fall. However, the final rule allows top rails and midrails to overhang the terminal posts provided they do not pose a projection hazard. For example, employers may shape top rails and midrails so snag hazards do not exist. The provision is almost identical to the existing rule in § 1910.23(e)(1) and the construction fall protection standard in § 1926.502(b)(7).

The final rule is consistent with the A1264.1–2007 standard at Sections 5.4 and 5.6.3. OSHA did not receive any comments on the proposed provision and OSHA adopts the requirement as proposed.

Final paragraph (b)(8), like the proposed and construction fall protection standards (§ 1926.502(b)(8)), prohibits employers from using steel and plastic banding for top rails or midrails in guardrail systems. The preamble to the construction fall protection standard explained that although banding, particularly steel banding, often can withstand a 200-pound load, it also can tear easily if twisted (59 FR 40698). In addition, workers can cut their hands when they seize steel or plastic banding, especially in a fall, since banding often has sharp edges. OSHA notes that, like the construction fall protection standard, final paragraph (b)(8) does not prohibit the use of steel or synthetic rope on top rails and midrails because rope does not have sharp edges. OSHA reminds employers, as discussed in final paragraph (b)(15) and similar to the construction rule, that manila or synthetic rope used for top rails must be inspected as necessary to ensure the rope meets the strength requirements of this section. OSHA did not receive any comments on the proposed provision and adopts it as discussed above.

Final paragraph (b)(9), like the proposed rule, requires that employers ensure top rails and midrails of guardrail systems are at least one-quarter inch in diameter or thickness. The final rule applies to all top rails and midrails, regardless of the material employers use for those rails. The final rule uses both "diameter" and "thickness" because top rails and midrails may have different shapes (*e.g.*, cylindrical or rectangular).

OSHA based final paragraph (b)(9) on the construction fall protection standard (§ 1926.502(b)(9)). The final paragraph ensures that whatever material an employer uses for top rails or midrails, it is not so narrow that workers grabbing onto the top rail or midrail may cut their hands. Such injuries could occur if employers use narrow, high strength rope or wire for top rails or midrails. To eliminate the possibility of injury, employers must ensure that all top rails and midrails are at least one-quarter inch in diameter/thickness. OSHA did not receive any comments on the proposed provision and adopts it as discussed above.

Final paragraph (b)(10) requires that employers using guardrail systems at hoist areas place a removable guardrail section or, in the alternative, chains or

a gate consisting of a top and midrail, across the access opening between guardrail sections when workers are not performing hoisting operations. This requirement ensures workers do not fall through an opening accidentally when materials are not being hoisted. It also gives employers flexibility in determining how to effectively guard access openings at hoist areas.

OSHA stresses that employers may use chains and gates as an alternative to removable guardrails, but only when the chains and gates provide a level of safety that is "equivalent" to the level of protection provided by removable guardrails. As defined in final § 1910.21(b), "equivalent" means that the alternative means "will provide an equal or greater degree of safety."

OSHA clarified final paragraph (b)(10) in response to comments stakeholders raised on several issues. First, in response to a comment from Mercer ORC (Ex. 254), the final rule clarifies that employers may use any of the following three alternatives to guard openings to hoist areas:

- Removable guardrail sections;
- Chains that provide protection at least at the top and midrail level; or
- A gate consisting of a top rail and midrail.

A typographical error (*i.e.*, missing comma) in the proposed rule made it appear that employers could only use a removable guardrail section or "chain gate." However, OSHA believes that both chains and gates that include protection at the top rail and midrail levels provide protection at hoist areas that is equivalent to removable guardrail sections.

Second, on a related issue, Mercer ORC requested clarification about whether a "chain gate" must have one or two chains (Ex. 254). Final paragraph (b)(10) clarifies that any alternative the employer uses to guard the access area when workers are not performing hoisting operations must have a top rail and a midrail to provide workers with protection that is equivalent to a guardrail system. OSHA does not believe that a single bar or chain provides protection that is equivalent to a guardrail system. This clarification is consistent with OSHA's 1990 proposed rule and letters of interpretation on the use of gates and chains to protect workers from falling through access openings in hoist areas when they are not performing hoisting operations (*e.g.*, Letter to Mr. Stephen Hazelton (5/23/2005⁶⁶); letter to Mr. Erich Bredl (1/15/

⁶⁶ OSHA letter to Mr. Stephen Hazelton available at: <https://www.osha.gov/pls/oshaweb/>

1993)⁶⁷). In the letter to Mr. Bredl, OSHA said “employee protection at access openings [must] be equivalent to that of the guardrail system.”

Finally, Ellis opposed the use of chains to guard access openings at hoist areas (Ex. 155). He said chains “cannot meet the sag requirements of the standard and an overbalance hazard can occur” (Ex. 155). OSHA does not agree with Ellis’ recommendation, noting that neither the proposed nor final rules establish a sag requirement for chains used at hoisting areas. In addition, OSHA notes that Ellis does not explain or provide any information about what constitutes an “overbalance” hazard. Nevertheless, OSHA clarified the language in final paragraph (b)(10) to indicate that chains and gates are alternatives that employers may use instead of removable guardrail sections when they provide a level of safety equivalent to guardrails. However, if chains sag so low that they do not meet the minimum guardrail height requirements (see final paragraph (b)(1)), or are not as effective as a removable guardrail section in preventing workers from falling through access openings, employers would have to use removable guardrail sections or a gate instead.

The final rule is almost identical to the proposed rule and construction fall protection standard in § 1926.502(b)(10), and OSHA adopts it with the clarifications discussed above.

Final paragraphs (b)(11) through (13) establish criteria for the use of guardrail systems to protect employees working near holes. Final paragraph (b)(11) requires that employers ensure that when guardrail systems are used around holes, they are installed on all unprotected sides or edges of the hole. As discussed earlier in this preamble, final § 1910.21(b) defines “hole” as “a gap or open space in a floor, roof, horizontal walking-working surface, or similar surface that is at least 2 inches (5 cm) in its least dimension.”

The final rule consolidates into one provision the various requirements in the existing rule that pertain to criteria for protecting workers from falling through holes. Final paragraph (b)(11) is almost identical to the proposed rule, and OSHA’s construction fall protection industry standard in § 1926.502(b)(11). OSHA did not receive any comments on the proposed provision and finalizes it as discussed.

owadis.show_document?p_table=INTERPRETATIONS&p_id=25100.

⁶⁷ OSHA letter to Mr. Erich Bredl available at: https://www.osha.gov/pls/oshaweb/owadis.show_document?p_table=INTERPRETATIONS&p_id=20991.

Final paragraph (b)(12), like the proposed rule and construction fall protection standard (§ 1926.502(b)(12)), establishes requirements for guardrail systems erected around holes through which materials may be passed. The final rule requires:

- When workers are passing materials through a hole, employers must ensure that not more than two sides of the guardrail system are removed (final § 1910.29(b)(12)(i)); and
- When workers are not passing materials through the hole, employers must ensure a guardrail system is installed on all unprotected sides and edges, or close the hole with a cover (final § 1910.29(b)(12)(ii)).

The final rule reorganizes and revises the proposed provision to make it easier to understand and follow. Final paragraph (b)(12) also updates the existing rule in § 1910.23(a)(7), which does not contain a provision addressing guarding holes when workers pass materials through the holes. The final rule generally is consistent with A1264.1–2007 (Section 3.5) and A10.18–2012 (Section 7.1). OSHA notes the A1264.1 standard allows employers to use an attendant if a hole is uncovered and guardrails are removed. However, OSHA believes that requiring guardrails on all sides of the hole is more protective than using an attendant.

The final rule allows employers to remove guardrail sections on no more than two sides of a hole when materials are being passed through the hole (paragraph (b)(12)(i)). In other words, the final rule does not allow the other guardrail sections to be removed during the time materials are moving through the hole to protect other workers who may be in the area. Final paragraph (b)(12)(ii) also protects workers by requiring guardrails on all unprotected sides of the hole or covering it when workers are not passing materials through the hole. OSHA did not receive any comments on the proposed provision and finalizes it as discussed.

Final paragraph (b)(13), similar to the proposed rule and construction fall protection standard (§ 1926.502(b)(13)), requires that employers using guardrail systems around holes that are points of access, such as ladderway openings, protect workers from walking or falling into the hole by installing gates at the opening in the guardrail system (final paragraph (b)(13)(i)), or offsetting the opening from the hole so workers cannot walk or fall into the hole (final paragraph (b)(13)(ii)). The final rule also revises the proposed criteria for such gates by specifying that they:

- Must be self-closing;

- Must either slide or swing away from the hole; and
- Be equipped with top rails and midrails or equivalent intermediate members that meet the requirements in final paragraph (b) (final paragraph (b)(13)(i)).

The final provision is consistent with A1264.1–2007 (Section 3.2 and E3.2). The ANSI/ASSE standard requires that ladderway floor openings be guarded to prevent workers from falling into the hole and explicitly notes self-closing gates that swing away from the ladderway hole and offsets are two methods of guarding those openings.

OSHA revised the proposed criteria for guardrail opening gates for two reasons. First, the revisions make final paragraph (b)(13) consistent with final § 1910.28. As discussed, final § 1910.28(b)(3)(iv) replaced “swinging gate” with “self-closing gate” to give employers flexibility to use sliding gates at guardrail access openings. OSHA believes sliding gates that are self-closing are as effective as swinging gates that self-close and are readily available and in use today.

Second, the revisions in the final rule respond to stakeholder questions and recommendations urging OSHA to identify more clearly the criteria for access opening gates must meet (Exs. 68; 254; 366). For example, Eric Bredl, with Intrepid Industries Inc., a safety gate manufacturer, said the final rule needs to clarify and define “safety gate (swinging gate)” used at openings in guardrail systems used around points of access holes (e.g., ladderways):

There have been many interpretations as to what constitutes a safety gate. It is not well defined, nor has it been well defined for several years (Ex. 68).

Mr. Bredl also requested that OSHA clarify whether gates used at guardrail openings must be equipped with midrails:

[T]he OSHA wording of this proposal does not clarify that the space to be protected must conform to the guardrail. Does OSHA want to allow a single member (chain or single bar) or two bars that are less than 19” apart as adequate protection for ladderway openings? (Ex. 366).

Similarly, Mercer ORC said OSHA needs to define the “specific type of gate” it intends to require for gates used for guardrail openings near points of access holes, and answer the following questions about midrails:

Must a “swinging gate” have both a top rail and midrail, like a standard railing? Or is a gate with only a top rail adequate to prevent an employee from walking “directly into the hole”? The existing rule is silent on the issue, but OSHA implied in the 1990 proposal and,

in subsequent discussions and letters of interpretation, has stated that a two-rail configuration is required (Ex. 254).

Mercer ORC opposed requiring that guardrail opening gates be equipped with midrails, saying that several companies and a safety gate manufacturer indicated that OSHA's "interpretation has not been accepted by a large number of employers" (Ex. 254).

Although Mr. Bredl acknowledged that when OSHA first issued the 1990 proposed rule, which would have required that guardrail opening gates comply with guardrail requirements (*i.e.*, have top rails and midrails), "this was 'foreign' to industry" (Ex. 366). However, he added that "[s]ince then, a majority of protection devices have both a top rail and a midrail similar to that of the guardrail" (Ex. 366).

The purpose of guardrail opening gates used around holes that serve as points of access (*e.g.*, ladderways) is, when open, to provide a means of access to holes, and, when closed, to provide guardrail protection that meets of the guardrail criteria in final paragraph (b). Accordingly, final paragraph (b) requires, among other things, that guardrails have both top rails and midrails or equivalent intermediate members, such as screens, solid panels, or intermediate vertical members, to ensure that closed access gates provide adequate guardrail protection.

OSHA believes that employers should not experience difficulty complying with the final rule. If an existing gate does not have a midrail or equivalent intermediate member, OSHA believes it is feasible for employers to add one. Therefore, OSHA adopts final paragraph (b)(13) with the revisions and clarification discussed above.

Final paragraph (b)(14), which is almost identical to the proposal, and the construction fall protection standard in § 1926.502(b)(14), requires that employers ensure guardrail systems on ramps and runways are installed along each unprotected side or edge. The existing rule in § 1910.23(c)(2) and A1264.1–2007 (Section 5.2) contain similar requirements for runways, but do not specifically address guarding ramps. OSHA believes it is appropriate to apply this provision to ramps as well as runways because both walking-working surfaces can have open sides. In addition, like runways, ramps can have open sides that are four feet or more above a lower level, which presents a fall hazard to workers. OSHA did not receive any comments on the proposal and adopts it as discussed above.

Final paragraph (b)(15), similar to the proposed rule, requires that employers ensure manila and synthetic rope⁶⁸ used for top rails or midrails of guardrail systems are inspected as frequently as necessary to ensure that the rope continues to meet the strength requirements in final paragraphs (b)(3) (top rails) and (b)(5) (midrails) of this section. OSHA believes inspecting manila and synthetic rope is important to ensure that it remains in serviceable condition, and that workers are not at risk of harm due to damage or deterioration. OSHA drew this requirement from the Agency's construction fall protection standard in § 1926.502(b)(15). The existing rule does not include a similar provision.

OSHA received two comments on the proposed provision. The National Institute for Occupational Safety and Health (NIOSH) recommended that OSHA incorporate in final paragraph (b)(15) the strength requirements for midrails (final paragraph (b)(5)) in addition to the strength requirements for top rails (final paragraph (b)(3)) (Ex. 164). OSHA agrees and incorporates the midrail strength requirements in final paragraph (b)(15).

Peter Catlos opposed allowing employers to use manila, plastic, or synthetic rope for top rails and midrails. He pointed out, "Based on the mechanical characteristics of these materials, such as high elongation and high elastic recovery, guardrails could be constructed that meet the requirements of the § 1910.29(b) as written, yet offer no practical restraint whatsoever, thereby creating an unsafe condition" (Ex. 203). OSHA believes that requiring employers to inspect ropes "as necessary" helps to ensure that the top rails and midrails made of such rope will continue to comply with the strength requirements in final § 1910.29(b)(3) and (5).

Final paragraph (b) includes an informational note that OSHA proposed as paragraph (b)(16). The note reminds employers that criteria and practice requirements for guardrail systems on scaffolds used in general industry are in the construction scaffold standards (29 CFR part 1926, subpart L, Scaffolds). This provision is a companion to final § 1910.28(b)(12)(i), which requires that employers protect employees working on scaffolds in accordance with the construction scaffold standards. These companion provisions ensure that employers who use scaffolds to perform both general industry and construction

activities will have one consistent set of requirements to follow. OSHA believes this approach will increase understanding of, and promote compliance with, the final rule, a conclusion Ameren supported because it would promote consistent application for employers who use scaffolds to perform both general industry and construction activities (Ex. 189). OSHA did not receive any comments opposing the proposed provision and adopts the note as discussed.

Ellis recommended OSHA include additional guardrail criteria in the final rule (Ex. 155). He recommended prohibiting guardrails from being used as personal fall protection anchorages unless approved and marked by a registered structural engineer, and that horizontal rails in wood guardrails be attached on the inside of the posts so the nails are not pushed out in a fall.

With regard to using guardrails as personal fall protection anchorages, final § 1910.140 requires that anchorages be capable of supporting 5,000 pounds. Therefore, unless the guardrail is designed to meet all the requirements for anchorages in final § 1910.140, they already are prohibited from such use.

Although OSHA agrees with Ellis on the placement of wood rails, the Agency does not believe it is necessary to regulate guardrail systems to this detail. Employers are responsible for ensuring that guardrail systems are erected to meet the strength requirements specified in the final rule.

Paragraph (c)—Safety Net Systems

Final paragraph (c), like the proposed rule, requires that general industry employers ensure all safety net systems they use meet the criteria and practice requirements in 29 CFR part 1926, subpart M, Fall protection. Neither the existing subpart D nor other provisions in 29 CFR part 1910 address safety net systems.

Final § 1910.28 allows employers to use safety net systems to protect workers on several types of elevated walking-working surfaces, including unprotected sides and edges, wall openings, and low-slope roofs. To ensure that the requirements for safety net systems used in general industry are consistent with, and are as protective as, the construction requirements, OSHA requires employers working in general industry to follow the construction criteria and practice requirements for safety net systems. Incorporating by reference the construction safety net system requirements also eliminates unnecessary repetition of the construction requirements.

⁶⁸ Synthetic rope includes plastic rope, therefore, OSHA does not carry forward in the final rule the term "plastic."

OSHA received two comments on this requirement, both of which supported making the general industry requirements for safety net system criteria and practices as protective as those in the construction fall protection standard in § 1926.502(c) (Exs. 155; 226). The American Federation of State, County and Municipal Employees (AFSCME) said the requirements for safety net systems used in general industry should be “no less” protective than the provisions in the construction standard (Ex. 226). In the same comment, AFSCME raised an issue about the difference in testing requirements for safety net systems and personal fall arrest systems and anchorages, saying the 400-pound drop-test requirement for safety net systems is “stricter” than the requirement for personal fall arrest systems and anchorages (Ex. 226). OSHA notes the 400-pound drop-test requirement is consistent with the construction fall protection standard in § 1926.502(c)(4)(i).

OSHA agrees with the commenters that the safety net system requirements in the final rule should be as protective as the requirements in the construction fall protection standard. In addition, OSHA believes that making the general industry and construction requirements consistent will make the rule easier to understand and follow for those employers who perform both general industry and construction operations.

In the proposal, OSHA also requested comment about whether the final rule should require that employers meet the requirements for safety net systems in the construction fall protection standard or list the specific construction safety net system requirements in the final rule (75 FR 28895). Ellis supported incorporating the construction standard by reference (Ex. 155). AFSCME, however, recommended that OSHA include the specific safety net system criteria and practice requirements in final § 1910.29(c), stating, “Referencing the construction standard, CFR § 1926.502(c), may not be helpful to employers who normally do not use the construction standards; therefore information on the requirements and testing of the safety net systems should be covered in the General Industry Standard” (Ex. 226).

After reviewing the record, OSHA decided to incorporate by reference into this final rule the safety net system requirements in the construction fall protection standard. OSHA notes that the final rule also incorporates by reference the construction scaffold requirements. OSHA does not agree with AFSCME that general industry

employers who do not use construction standards will have a difficult time obtaining them. OSHA’s construction standards are readily available online at www.osha.gov, along with other guidance materials, which will facilitate obtaining, and complying with, the construction safety net provisions. In addition, OSHA believes that having a single set of safety net system requirements to follow should make compliance easier for employers who perform both general industry and construction activities.

Ellis raised another issue about safety nets. He recommended that the final rule allow the use of “platform nets” in general industry, provided those nets also complied with the requirements in the construction standard in § 1926.502(c). He observed, “[Platform nets] are not only for catching falling workers they are also for working from if the mesh or fabric is tight enough to prevent the foot from going through. These nets . . . are finding considerable use around the world for construction and maintenance work and provide both access and a walking-working surface” (Ex. 155).

The final rule does not prohibit the use of platform nets. However, if employers also use platform nets for fall protection, the nets must meet the criteria and practice requirements in the construction fall protection standard.

Paragraph (d)—Designated Areas

Final paragraph (d), like the proposed rule, establishes criteria and practices for “designated areas,” which the final rule in § 1910.21(b) defines as “a distinct portion of a walking-working surface delineated by a warning line in which employees may perform work without additional fall protection.” Designated areas are non-conventional controls for addressing fall hazards.

As mentioned earlier in this preamble, final § 1910.28(b)(13) limits the use of designated areas to one situation: Work on low-slope roofs. The final rule in § 1910.21(b) defines “low-slope roof” as “a roof that has a slope less than or equal to a ratio of 4 in 12 (vertical to horizontal).” Final § 1910.28(b)(13) limits the use of designated areas to work on low-slope roofs performed at least six (6) feet from the roof edge and requires that employers use conventional controls (e.g., guardrail systems, safety net systems, personal fall arrest systems) if workers are less than six (6) feet from the roof edge. In the area that is 6 feet to less than 15 feet from the edge, employers may use designated areas when their employees perform work that is both temporary and infrequent.

Where employers perform work that is 15 feet or more from the edge, they also can use a designated area for any work (i.e., without regard to frequency or duration of the work). In addition, the final rule does not require that employers provide any fall protection or use a designated area when employees perform work that is both temporary and infrequent and the work is 15 feet or more from the roof edge.

Proposed § 1910.28(b)(1), (7), and (13) allowed general industry employers to use designated areas in additional situations: On unprotected sides and edges of walking-working surfaces, at wall openings, and on walking-working surfaces the final rule does not specifically address. However, as discussed in the preamble to § 1910.28, OSHA believes that employers must use designated areas, like warning line systems in the construction fall protection standard, only in “a few, very specific situations” (see, e.g., letter to Mr. Keith Harkins (11/15/2002)⁶⁹). Allowing the use of designated areas only on low-slope roofs makes the final rule consistent with limited use specified by the construction standard for non-conventional controls. (See further the discussion of designated areas in the preamble to final § 1910.28(b).)

Final paragraph (d)(1) establishes general criteria and practice requirements for the use of designated areas on low-slope roofs. Final paragraph (d)(1) revises the proposed requirements by deleting, as unnecessary, the language in proposed paragraph (d)(1)(iii) requiring employers use designated areas only on “surfaces that have a slope from horizontal of 10 degree or less,” since that is now contained in the definition of a low-slope roof.

Final paragraph (d)(1)(i), like the proposed rule, requires that employers ensure workers remain within the designated area during work operations. Going outside of the designated area will increase the risk of a worker falling off the roof edge. If workers must go outside the designated area, they must be protected by conventional fall protection systems. OSHA did not receive any comments on the proposed requirement and finalizes it as discussed.

Final paragraph (d)(1)(ii), similar to the proposed rule, requires that employers delineate the perimeter of designated areas with a warning line.

⁶⁹ Letter to Mr. Keith Harkins available on OSHA’s Web site at: https://www.osha.gov/pls/oshaweb/owadisp.show_document?p_table=INTERPRETATIONS&p_id=24552.

The final rule in § 1910.21(b) defines “warning line” as “a barrier erected to warn employees that they are approaching an unprotected side or edge, and which designates an area in which work may take place without the use of other means of fall protection.”

Final paragraph (d)(1)(ii) also specifies warning lines may consist of ropes, wires, tape, or chains that employers ensure meet the requirements of final paragraphs (d)(2) and (3). Final paragraphs (d)(2) and (3) contain specific requirements for warning lines, for example, they must be installed so the lowest point of the line, including sag, is not less than 34 inches (86 cm) and not more than 39 inches (99 cm) above the walking-working surface (final paragraph (d)(2)(i)).

The final rule generally is consistent with the requirements for warning line systems in the construction fall protection standard in § 1926.502(f)(1).

Northrop Grumman Shipbuilding (NGS) recommended that OSHA give employers more flexibility to demarcate designated areas by using materials other than ropes, wires, tape, chains, and supporting devices, stating:

[W]e recommend that a contrasting color marking on the floor or roof surface be another acceptable means of delineating the designated area. Note that this is similar to the options provided in proposed 1910.28(b)(8) for pits. Colored markings are the best means to permanently mark pathways and work areas for maintenance of rooftop equipment, thus eliminating the hazards associated with getting stanchions and rope or chain to the job site. Stanchions typically cannot be permanently attached to rooftops because they will damage the roof surface and they cannot be left in place because they pose a projectile hazard in the event of high winds (Ex. 180).

OSHA agrees that using warning line materials made of contrasting colors, such as brightly-colored ropes or tape makes the line “clearly visible,” which final paragraph (d)(2)(iv) requires. However, OSHA believes that painting the surface of the roof instead of attaching warning line materials to supporting devices does not provide a clearly visible perimeter throughout the designated area as required by final paragraph (d)(2)(iv). To be clearly visible, OSHA believes materials used to demarcate a designated area need to be high enough above the walking-working surface to be visible from a distance at least 25 feet away, as well as anywhere within the designated area, and not obscured by materials, tools, and equipment that may be in the designated area.

NGS also pointed out that the proposed rule would allow employers to

apply floor markings, instead of erecting warning lines, to demarcate vehicle repair, services, and assembly pits (see proposed and final § 1910.28(b)(8)(ii)). OSHA does not consider the working conditions on low-slope roofs to be similar enough to the working conditions at vehicle repair, service, and assembly pits to permit the use of floor markings. OSHA allows employers to apply floor markings to delineate vehicle repair, service, and assembly pits that are less than 10 feet deep because the pits often are so close together that using warning lines would impede movement of vehicles and equipment around and over the pits, which is not true for work on low-slope roofs.

Final paragraph (d)(2) establishes criteria and practice requirements for warning lines. As part of these requirements, final paragraph (d)(2)(i) specifies that employers ensure warning lines have a minimum breaking strength of 200 pounds. The proposed rule in paragraph (d)(2)(ii) would have required that employers ensure the warning line has a 500-pound minimum breaking or tensile strength and, after being attached to the stanchions, is capable of supporting the loads applied to the stanchions as prescribed in proposed paragraph (d)(2)(i). Proposed paragraph (d)(2)(i) also would have required that stanchions be capable of resisting, without tipping over, a force of at least 16 pounds applied horizontally against the stanchion. The force would have been required to be applied 30 inches above the work surface. OSHA drew the proposed requirement from the construction warning line system requirements for roof work performed on low-slope roofs (see § 1926.502(f)(2)(iv)). OSHA explained in the proposal that the requirement would ensure the warning line is “durable and capable of functioning as intended, regardless of how far apart the stanchions are placed” (75 FR 28896). In addition, OSHA said the proposed strength requirement would ensure that employers use substantial materials for warning lines, such as chains, ropes, or heavy cord. OSHA also requested comment on the appropriateness of requiring warning lines to have a tensile strength of 500 pounds (similar to construction warning line system requirements), which “assures the line is made of material more substantial than string” (75 FR 28896).

Several stakeholders indicated carrying stanchions that meet the proposed strength requirement would be infeasible or create a greater hazard for workers (Exs. 165; 171; 296). For example, the National Chimney Sweep

Guild (NCSG) said, “The technician would be exposed to a greater fall hazard while transporting numerous stanchions weighing over 50 pounds to the roof.” Later, NCSG stated, “Stanchions would not meet the specified stability criterion unless they were either weighted to the point where they create an unacceptable fall hazard or attached to the roof” (Ex. 296). The Sheet Metal and Air Conditioning Contractors’ National Association (SMACNA) agreed, stating, “The placement of a designated area by the construction of a barrier system (rope, wire or chain supported by stanchions meeting specific design criteria) would create more safety hazards due to the transporting of barrier materials up to the roof” (Ex. 165). Verallia recommended that OSHA also reconsider the companion requirement in proposed paragraph (d)(2)(i) addressing the stability of stanchions, noting:

With respect to the specified size of the stanchions, 16 pounds resistance may be insufficient in some cases, while . . . completely unnecessary in others. The further the area is from the unprotected edge, the less is required to adequately protect (or warn) the affected employees.

The size and form of stanchions (or comparable barriers) should be left to the discretion of the employer, as long as they are effective in putting the employee on notice that a fall hazard may exist. . . . Moreover, there is an additional concern that the use and handling of 16-pound resistant stanchions could itself present an independent hazard and/or cause damage to roofs or working surfaces (Ex. 171).

After analyzing the entire rulemaking record on designated areas, OSHA has determined that the proposed 500-pound breaking strength requirement is not necessary to warn workers they are approaching a fall hazard on a low-slope roof. Therefore, in the final rule OSHA replaces the proposed requirement with a 200-pound minimum breaking strength requirement, which is consistent with the requirement for control lines in controlled access zones in the construction fall protection standard in § 1926.502(g)(3)(iii). OSHA believes that the strength requirement in the final rule, combined with the other requirements in final paragraph (d)(2), will ensure that the delineation of designated areas is sturdy and provides adequate warning to workers.

In addition, in response to these commenters, the final rule also deletes the stanchion stability requirement specified by proposed paragraph (d)(2)(i), which would have required that employers ensure stanchions are “capable of resisting, without tipping over, a force of at least 16 pounds (71

N) applied horizontally against the stanchion.” The Agency drew proposed paragraph (d)(2)(i) from the construction warning line system requirements in § 1926.502(f)(2)(iii). OSHA believes this deletion will give employers greater flexibility in selecting supporting devices to delineate designated areas. OSHA will consider employers who erect designated area warning lines that meet the requirements of proposed paragraphs (d)(2)(i) and (d)(2)(ii) (*i.e.*, using stanchions that meet the 16-pound force resistance) to be in compliance with the final rule; however, OSHA notes the final rule does not require that stanchions meet those requirements.

Final paragraph (d)(2)(ii), like proposed paragraph (d)(2)(iv), requires that employers install warning lines so the lowest point, including any sag, is not less than 34 inches or more than 39 inches above the walking-working surface. The final rule is consistent with the warning line system requirement in the construction fall protection standard in § 1926.502(f)(2)(ii).

NGS recommended that the final rule permit employers to use contrasting color marking on the floor or roof instead of erecting warning lines at 34 to 39 inches above the walking-working surface (Ex. 180). As discussed above, the final rule does not include NGS’ recommendation. OSHA believes the warning line height specified in the final rule is necessary to adequately warn workers that they are approaching the boundary of a designated area. At a height of between 34 to 39 inches, warning lines will be more visible than if employers paint them on the surface of the roof. Moreover, at the height the final rule requires, warning lines will be visible even if equipment, tools, or objects are near the warning line.

OSHA also rejects NGS’s recommendation because painting warning lines on surfaces makes them permanent, thus suggesting that employers may use designated areas for any operation regularly or routinely performed on a low-slope roof, rather than performing work in these areas that is both temporary and infrequent. As discussed earlier in this preamble, employers must provide conventional fall protection for routine, regular, or frequent work performed within 15 feet of the edge of low-slope roofs.

Final paragraph (d)(2)(iii) requires that employers ensure warning lines are supported in such a manner that pulling on one section of the line will not result in slack being taken up in any adjacent sections causing the line to fall below the limit of 34 inches at any point, as specified in (d)(2)(ii). Proposed

paragraph (d)(2)(iii) and the construction fall protection standard in § 1926.502(f)(2)(v) require that taking up slack in adjacent sections of a warning line must not cause the supporting devices to tip over. The final rule revises the proposed provision for two reasons. First, the revised language ensures that the warning line will be visible at all times because it will remain at the height specified in final paragraph (d)(2)(ii). Second, the revisions ensure employers remain in compliance with final paragraph (d)(2)(ii). OSHA did not receive any comments on the proposal and adopts the requirement with the revisions discussed above.

Final paragraph (d)(2)(iv) requires that employers ensure warning lines are clearly visible from a distance of 25 feet away and anywhere within the designated area. The final rule clarifies proposed paragraph (d)(2)(v) by recasting the provision in plain language that is easier to understand than the proposed paragraph.

The proposed rule would have required that employers ensure the warning line is clearly visible from any unobstructed location within the designated area up to 25 feet away, or at the maximum distance a worker may be positioned away from the warning line, whichever is less. The final rule states more clearly than the proposed provision that employers must erect warning lines that are clearly visible within the designated area, regardless of where the employee is working in that area. That is, the warning line must be clearly visible when the worker is approaching the line. Whether the designated area is large or small, the final rule also requires that the warning line be visible at least 25 feet away. For large designated areas, requiring that warnings lines be visible at least 25 feet away ensures that workers have adequate warning when approaching fall hazards. Such warning is particularly necessary when workers use mobile mechanical equipment that can cover distances quickly. If workers cannot clearly see warning lines until the mobile equipment they are operating is near the boundary of the designated area, they may not be able to stop in time to prevent going past the boundary or over the edge of the roof. For designated areas that are small and close to the roof edge (*e.g.*, 6 feet from the edge), the 25-foot minimum visibility range adequately prepares workers for approaching the hazard zone.

As the proposal noted, there is a possibility that a portion of the warning line could be obstructed. This remains true in the final rule. As long as the

boundaries of the designated area are clearly visible within 25 feet and anywhere within the area, obstructions of some portion of the line are permissible.

The construction fall protection standard in § 1926.502(f)(2)(i) and (g)(3)(i) requires employers to flag warning lines with high-visibility material at least every 6 feet to ensure that the lines are visible. OSHA believes there is a greater need for visibility aids in construction operations because the work may be at leading edges or other areas close to the roof edge. Also, construction work is more likely than work in general industry to shift from one part of the roof to another because construction work often involves performing tasks that are not temporary and infrequent. Therefore, OSHA believes that it is appropriate to give general industry employers greater flexibility to select the measures they believe will make the warning line “clearly visible.” Accordingly, employers are free to comply with the final rule by flagging warning lines.

Final paragraph (d)(2)(v), like proposed paragraph (d)(3)(i), requires that employers erect warning lines as close to the work area as the task permits. This provision, like final paragraph (d)(2)(iv), helps to make warning lines as clearly visible as possible without interfering with the work employees perform. It also eases compliance for employers. Instead of placing warning lines 6 feet or 15 feet around the entire roof, employers can simply erect the warning line around the specific area where employees are working. This will make compliance easier for many employers, one of whom said, “Some flat roofs in general industry settings could be the size of several football fields” (Ex. 207).

Finally, OSHA believes the performance-based approach in the final rule gives employers flexibility to determine the distance that makes the warning line most clearly visible, without interfering with the work being performed. OSHA did not receive any comments on the proposed requirement and adopts it with the clarification discussed above.

Final paragraph (d)(2)(vi), similar to proposed paragraph (d)(3)(ii), requires that employers erect warning lines not less than 6 feet (1.8 m) from the roof edge for work that is both temporary and infrequent, or not less than 15 feet (4.6 m) for other work. OSHA believes the minimum distance of six feet for work that is temporary and infrequent provides an adequate safety zone that allows workers to stop moving toward the fall hazard after reaching or

contacting the perimeter line of the designated area and provides an adequate safety zone should a worker trip and fall at the edge of the designated area. This final provision is almost identical to the six-foot safety zone required for warning line systems in the construction fall protection standard in § 1926.502(f)(1)(i). OSHA added the requirement that warning lines not be erected less than 15 feet from the roof edge for other work to be consistent with final paragraph § 1910.28(b)(13)(iii) and OSHA's enforcement policy discussed above. OSHA did not receive any comments on the proposed requirement and adopts it as discussed.

Final paragraph (d)(3), like proposed paragraph (d)(3)(iii), establishes minimum distances from an unprotected side or edge for erecting warning lines when workers use mobile mechanical equipment to perform work that is both temporary and infrequent in a designated area. In such cases, the final rule requires that employers erect warning lines: (1) Not less than 6 feet from the unprotected side or edge that is parallel to the direction in which workers are using the mechanical equipment; and (2) not less than 10 feet from the unprotected side or edge that is perpendicular to the direction in which workers are operating the mechanical equipment. When mobile mechanical equipment is used to perform other work, a warning line must be erected at least 15 feet from the roof edge.

The purpose of this final provision is to provide additional distance for the worker to stop the mechanical equipment from moving toward an unprotected side or edge. The 10-foot minimum distance provides a safety zone that takes into account the momentum of the equipment workers may be using. Final paragraph (d)(3), which OSHA renumbered in the final rule to make it easier to follow, is consistent with the construction fall protection standard in § 1926.502(f)(1)(ii). OSHA did not receive any comments on the proposed provision and finalizes it as discussed above.

Proposed paragraph (d)(4), which the final rule does not retain, required that employers provide clear access paths to designated areas. The proposal specified that the path have warning lines on both sides attached to stanchions that comply with the strength, height, and visibility requirements in proposed paragraph (d)(2). OSHA drew the proposed rule from the warning line system requirements in the construction fall

protection standard in § 1926.502(f)(1)(iii) and (iv).

OSHA requested comment on whether the proposed requirement is necessary to protect general industry workers when they travel to and from designated areas. AFSCME supported the proposed requirement, stating, "We believe that such an access path to the designated area is absolutely necessary for work on roofs when other fall protection is not provided" (Ex. 226). Other commenters recommended that OSHA give employers more flexibility in delineating access paths to designated areas (Exs. 180; 189). In this regard, NGS recommended allowing employers to use contrasting color markings painted on the roof to designate access paths (Ex. 180), while Ameren said OSHA should consider allowing employers to use rubber mats for access paths (Ex. 189).

Several commenters recommended that OSHA delete the proposed requirement. Ameren urged OSHA to delete the proposed requirement because it "could be burdensome if the path of travel to a work area on a roof is down the center of the roof especially if the delineation must be along the entire route and not just around the 'work area'" (Ex. 189). Clear Channel Outdoor, Inc. (CCO) said the proposed requirement was not necessary:

Based upon CCO's experience that employees do not trip or fall when traversing to and from the access ladder, CCO does not believe that installing an access path with safety cables or stations adds to safety in any measurable way. Accordingly, CCO supports the designated work area concept, but does not believe that a designated access path is necessary (Ex. 121).

Some commenters said the proposed access path requirement was not necessary because most of the work they perform on low-slope roofs is not near the edge of the roof (Exs. 165; 189; 236).

Based on stakeholder comments and other information in the record, OSHA decided not to retain proposed paragraph (d)(4) in the final rule. OSHA agrees with commenters that the proposed access path requirement is not necessary, especially on large roofs that require employers to erect long access paths. Evidence in the record suggests that many low-slope roofs in general industry are quite large. For example, Edison Electric Institute (EEI) commented that "[s]ome flat roofs in a general industry setting could be the size of several football fields" (Ex. 207). Although OSHA is deleting the proposed access path requirement, the Agency stresses that employers still must train workers, in accordance with

final § 1910.30, about the potential fall hazards in the work area, which includes accessing the work area, and the proper set-up and use of designated areas.

Paragraph (e)—Covers

Final paragraph (e) addresses criteria and practices for covers that employers use to protect workers from falling into a hole in a walking-working surface, including holes in floors, roofs, skylights, roadways, vehicle aisles, manholes, pits, and other walking-working surfaces. The final rule consolidates and updates the cover criteria and practice requirements in the existing rule (*e.g.*, existing §§ 1910.23(a)(5), (8), and (9), and 1910.23(e)(7) and (8)). In addition, the final rule consolidates the proposed cover requirements, which are similar to those in the construction fall protection standard in § 1926.502(i).

Final paragraph (e)(1) requires that employers ensure any cover they use to prevent workers from falling into a hole in a walking-working surface is capable of supporting, without failure, at least twice the maximum intended load that may be imposed on the cover at any one time. The final rule clarifies and simplifies the proposed rule, and makes it consistent with other provisions in the final rule, by replacing the proposed language with "maximum intended load," which OSHA consistently uses throughout the final rule. The final rule in § 1910.21(b) defines "maximum intended load" as the total load (weight and force) of all employees, equipment, vehicles, tools, materials, and other loads the employer reasonably anticipates to be applied to a walking-working surface at any one time; in this case, the walking-working surface is a cover. The final rule is consistent with A10.18–2012 (Section 7.1.1.4), which requires that trench and manhole covers support at least twice the maximum intended load.

The language in the final rule differs from the proposal, the construction fall protection standard, and the existing rule. The proposed and construction rules require that covers in roadways and vehicle aisles be capable of supporting "twice the maximum axle load of the largest vehicle expected to cross over the cover" (see proposed paragraph (e)(1) and § 1926.502(i)(1)), and that all other covers support "twice the weight of employees, equipment, and materials imposed on the cover at any one time" (proposed paragraph (e)(2)). The existing rule in § 1910.23(e)(7) states that trench, conduit, and manhole covers must support a truck rear-axle load of at least

20,000 pounds, and that floor-opening covers consist of “any material that meets the strength requirements.”⁷⁰

OSHA believes that using the single, uniform term “maximum intended load” makes the final rule easier to understand than the proposed rule, and is consistent with a number of other requirements in the final rule. In addition, the term clearly states that covers must be capable of supporting twice the weight and force expected to be placed on them. By using the term “maximum intended load,” which includes the weight and force of all vehicles, equipment, tools, materials, workers, and other loads, OSHA consolidates the cover requirements into a single provision that applies the same, uniform criteria to all covers. OSHA also believes that establishing a uniform standard for all covers eliminates potential confusion and needless repetition.

Ellis commented that the proposed rule did not define the “adequacy and walkability” of covers (Ex. 155). The Agency believes that paragraph (e)(1) of the final rule establishes “adequacy” criteria using performance-based measures (*i.e.*, support twice the maximum intended load), which is consistent with the OSH Act at Section 6(b)(5). OSHA believes this performance-based approach also gives employers flexibility in selecting the material for a cover that they believe best meets the requirement in final paragraph (e)(1). Thus, employers may use covers made of the materials Ellis suggests so long as the cover supports twice the maximum intended load. In this regard, Ellis noted:

A cover may be a plywood board or perhaps OSB or temporarily and more dangerously a section of drywall to keep out dust and weakens when wet. The new to America Platform Nets should be accommodated for maintenance work to allow walkable fabric covers to be used for walking across holes and open spaces (Ex. 155).

OSHA notes that Appendix A of A10.18–2012 (Ex. 388) provides information on hole covers, including material used for them, that provide additional guidance on the issue Ellis raises. As for “walkability,” if the employer anticipates that an employee will walk across a hole cover, the cover must meet the requirements of final § 1910.22.

Final paragraph (e)(2) (proposed paragraph (e)(3)) requires that employers secure covers to prevent accidental displacement. Accidental

displacement of hole covers can occur due to a number of factors. For example, weather conditions such as wind, floods, snow, and ice can cause covers to become displaced. Heavy equipment running back and forth over covers also can loosen or displace them.

The final rule expands and revises both the existing and proposed rules. The final rule expands existing § 1910.23(a)(9), which only applies to “floor holes,” to include holes in any walking-working surface that employers protect with covers. Final paragraph (e)(2) expands and revises the proposed rule in two ways. First, the final rule eliminates, as unnecessary, the examples in proposed paragraph (e)(3) of conditions that may cause displacement of covers. Second, the final rule revises the proposed language to make clear that employers must keep covers firmly secured at all times. The proposed rule in paragraph (e)(3), like the construction fall protection standard in § 1926.502(i)(3), only specified that employers secure covers firmly “when installed.” However, in light of Ellis’ comment that “[l]ong-term covers which are acknowledged to be weak or degrade in the elements should have minimum requirements to follow for safety and structural inspection” (Ex. 155), OSHA believes it is important to clarify that employers ensure that covers remain firmly secured after installation.

The final rule does not retain proposed paragraphs (e)(4) and (5). Proposed paragraph (e)(4) required that employers ensure covers were color coded or marked with the word “HOLE” or “COVER” to warn workers of the hazard. Proposed paragraph (e)(5) specified that proposed paragraph (e)(4) did not apply to cast-iron manhole covers or steel grates, such as those on streets and roadways. OSHA drew both proposed requirements from the construction fall protection standard in § 1926.502(i)(4).

In the proposed rule, OSHA requested comment on the need to include proposed paragraph (e)(4) in the final rule and information on the extent to which employers already mark or color code covers. OSHA received one comment on the proposed requirement. NGS said the proposed requirement was not necessary because “[t]he proposed standard already requires that covers be properly designed, constructed and secured, thus engineering out the hazard” (Ex. 180). OSHA agrees with this comment; the requirements in final paragraphs (e)(1) and (2), that employers ensure covers are strong enough to support the weight to be placed on them and are secured in place at all times, eliminates the need to also color code or

label them as a hazard. Covers that meet the requirements of the final rule are not hazards. Therefore, OSHA deletes proposed paragraph (e)(4) because it is unnecessary.

Since the final rule does not carry forward the proposed marking requirement, proposed paragraph (e)(5) exempting certain covers from that requirement is no longer necessary. NGS also said that proposed paragraph (e)(5) is not necessary (Ex. 180). They pointed out that “[m]anhole covers and steel grates are already exempt from the marking requirement” (Ex. 180). OSHA agrees. Final paragraphs (e)(1) and (2) provide adequate protection; therefore, the Agency is not carrying forward the provision in the final rule.

Paragraph (f)—Handrails and Stair Rail Systems

Final paragraph (f) sets criteria and practice requirements for handrails and stair rail systems. These requirements cover height, finger clearance, surfaces, stair rail openings, handholds, projection hazards, and strength. The final rule in § 1910.21(b) defines “stair rail system” as a barrier erected along the exposed or open side of stairways to prevent workers from falling to a lower level, while “handrails” are rails used to provide workers with a handhold for support.

In final paragraph (f)(1), which addresses handrail height criteria, OSHA revised the language on measuring height criteria to make it uniform and consistent throughout final paragraph (f)(1). For example, final paragraph (f)(1) incorporates uniform terminology (*i.e.*, leading edge, top surface) and simplifies how to measure handrail height. The final rule adopts the method in A1264.1–2007, which specifies that handrails be measured from the leading edge of the tread to the top of the handrail (paragraph (f)(1)(i)). New Figures D–12 and D–13 show how to make this measurement.

Final paragraph (f)(1)(i) requires that employers ensure each handrail is not less than 30 inches and not more than 38 inches high, as measured from the leading edge of the stair tread to the top surface of the handrail. The height criteria in final paragraph (f)(1)(i) differs from the handrail height in both the existing and proposed rules. Existing § 1910.23(e)(5)(ii) requires that handrails be between 30 and 34 inches in height. The proposed rule required the height of handrails to be between 30 and 37 inches as measured from the upper surface of the top rail to the surface of the tread, in line with the face of the riser at the forward edge of the tread, which is consistent with both the

⁷⁰ OSHA notes that A10.18–2012 (Section 7.1.1.3) is consistent with the proposed rule.

construction stairways standard in § 1926.1052(c)(6) and A10.18–2012 (Section 6.2). The A1264.1–2007 standard, on the other hand, specifies that the handrail height must be not less than 34 inches or not more than 38 inches as measured from the tread to the top of the handrail.

OSHA revised the final rule in response to a comment from the National Fire Protection Association (NFPA), which pointed out that the NFPA 101 Life Safety Code, an “ANSI-accredited national expert code,” permits a 38-inch maximum handrail height (Ex. 97). NFPA recommended that the final rule also allow a 38-inch handrail height so handrails built in accordance with the NFPA 101–2012, Life Safety Code (Ex. 385) would not be “non-compliant” (Ex. 97). NFPA also said that their recommendation was “technically sound as borne out by the research of Jake Pauls while he was on staff at the National Research Council Canada in the 1970s and 1980s” (Ex. 97). In addition, NFPA appeared to suggest a 38-inch maximum handrail height would provide support for a broader range of workers (*i.e.*, taller workers) without compromising the protection of any worker (Ex. 97).

OSHA agrees that handrails built in accordance with NFPA 101 are acceptable, and is adopting this recommendation in the final rule; therefore, in the final rule the Agency increased the maximum handrail height by one inch, from 37 inches to 38 inches, which Figure D–12 illustrates. Since both the existing and proposed handrail height requirements come within revised final paragraph (f)(1)(i), OSHA does not expect that employers will have any problems complying with the final rule. The final rule simply provides employers with greater compliance flexibility.

Final paragraph (f)(1)(ii) establishes the height requirement for stair rail systems. Employers must ensure:

- The height of stair rail systems installed *before* the effective date of the final rule, which is January 17, 2017, is not less than 30 inches as measured from the leading edge of the stair tread to the top surface of the top rail (paragraph (f)(1)(ii)(A)); and
- The height of stair rail systems installed *on or after* the effective date is not less than 42 inches as measured from the leading edge of the stair tread to the top surface of the top rail (paragraph (f)(1)(ii)(B)).

The final rule revises the requirements in both the existing and proposed rules. The existing rule in § 1910.23(e)(2) requires that the height of a stair railing be not less than 30

inches nor more than 34 inches as measured from the upper surface of the stair tread to the top edge of the top rail. The final rule eliminates the maximum height requirement for existing stair rail systems.

The proposed rule would have raised the minimum height of new and replacement stair rails to 36 inches. The final rule, however, requires that new and replacement systems be at least 42 inches in height. In the proposed rule, OSHA explained that a 36-inch minimum height would make the general industry requirement consistent with the construction stairways standard in § 1926.1052(c)(3), and would afford a reasonable level of safety to workers (75 FR 28897). However, OSHA also discussed a University of Michigan study indicating that the minimum stair rail system height should be 42 inches, and also suggested that even 42 inches may not be adequate (Ex. OSHA–S041–2006–0666–0004). OSHA also noted that A1264.1–2007 (Section 5.5) establishes a 42-inch maximum stair rail system height. The Agency requested comment about raising the minimum stair rail system height to 42 inches.

OSHA received one comment. NFPA recommended raising the minimum height of stair rail systems to 42 inches, which would make the final rule consistent with the NFPA 101 Life Safety Code (Ex. 97). NFPA indicated that a 42-inch minimum stair rail system height would be more protective than the proposed height, and that research supported the 42-inch minimum height. Accordingly, NFPA stated, “A minimum 42-inch high guard is needed to prevent a ninety-fifth percentile male from falling over the rail upon striking the side of a stair. This was documented in Jake Pauls’ work of the 1970s and 1980s while he was on staff at the National Research Council Canada” (Ex. 97). NFPA also said that the University of Michigan study supported raising the minimum stair rail system height. OSHA agrees that NFPA’s recommendation would make the final rule more protective for a broader range of workers than the proposed rule and, therefore, requires that stair rail systems installed on or after the effective date of the final rule be at least 42 inches as measured from the leading edge of the stair tread to the top surface of the top rail. OSHA notes A10.18–2012 (Sections 4.1.2 and 5.2) requires that stair rail systems be 42 inches, plus or minus three inches.

OSHA also requested comment about whether the final rule should establish a maximum height for stair rail systems like A1264.1–2007. In the preamble to

the proposal, OSHA said the purpose of stair rail systems is to prevent workers from falling over the edge of open-sided stairways, and that eliminating a maximum height would give employers greater flexibility to install stair rail systems they considered to be safer (75 FR 28897).

OSHA notes that the 42-inch stair rail height (final paragraph (f)(1)(ii)(B)) is prospective. It only applies to new and replacement stair rail systems installed on or after January 17, 2017.

Under the proposed rule, the new height requirements would have taken effect 90 days after the effective date, and Ameren recommended lengthening the phase-in period, saying, “Lead time for material orders are often quite longer than three months often up to years to order material for large capital projects.” Ameren stated later, “Stipulations of ‘ordered’ material should be imposed in regard to the date of the final rule because the time between ordering and placing into service is often greater than 90 days” (Ex. 189).

However, OSHA believes 60 days gives employers adequate time to come into compliance with the final rule and to change the specifications of any stair rail systems they have on order. The NFPA 101 Life Safety Code has been in place for a number of years, and the NFPA said that today stair rail systems “are being installed at a minimum 42-inch height for compliance with nationally-recognized, expert model codes like NFPA 101 Life Safety Code” (Ex. 97). Accordingly, OSHA believes most employers already are in compliance with the final rule, and the remainder will be able to comply with this prospective requirement when the final rule becomes effective. The final rule will not affect existing stair rail systems; therefore, there is no requirement to retrofit stair rail systems. The final rule will continue to allow stair rails installed before the new requirement takes effect to meet the existing requirement.

Finally, OSHA deleted the proposed note to paragraphs (f)(1)(i) and (ii) because it is unnecessary. The proposed note explained the criteria for measuring the height of handrails and stair rail systems. The final rule includes the measurement criteria in final paragraphs (f)(1)(i) and (ii). OSHA believes this deletion makes the final rule easier to read and follow than the proposal.

Final paragraph (f)(1)(iii) permits employers to use the top rail of stair rail systems as a handrail only when:

- The height of the stair rail system, which Figure D–13 illustrates, is not less than 36 inches and not more than

38 inches as measured at the leading edge of the stair tread to the top edge of the top rail (final paragraph (f)(1)(iii)(A)); and

- The top rail of the stair rail system meets the other handrail requirements in final paragraph (f) of this section (final paragraph (f)(1)(iii)(B)).

The proposed provision was consistent with the construction stairways standard in § 1926.1052(c)(7), which also allows employers to use top rails of stair rail systems as a handrail under specified conditions. OSHA believes a top rail of a stair rail system, under some conditions, may effectively and safely perform the function of both a stair rail system and handrail. Allowing employers to use stair rail top rails as handrails under these conditions provides employers with compliance flexibility without compromising worker safety when employers comply with the required conditions of use.

In response to NFPA's comments, OSHA revised final paragraph (f)(1)(iii) in three ways. First, for the reasons discussed final paragraph (f)(1)(i), the final rule raises the required height of stair rail top rails used as handrails to not less than 36 inches, but not more than 38 inches, from the proposed height of not less than 36 inches, but not more than 37 inches. This change makes the final rule consistent with the NFPA 101 Life Safety Code, and will protect a broader range of workers (Ex. 97).

Second, because the final rule requires that all stair rail systems installed on or after the effective date, which is January 17, 2017, must be at least 42 inches in height, final paragraph (f)(1)(iii)(A) is only applicable to stair rail systems installed before the effective date. Third, OSHA adds to the final rule the requirement that employers may use stair rails as handrails only if the stair rails also meet the other requirements in paragraph (f). NFPA recommended that OSHA allow the use of stair rails as handrails only if they also meet the handhold requirements in proposed paragraph (f)(5). NFPA recommended an addition to the proposed provision, stating:

[The addition] recognize[s] the stair rail as an acceptable handrail not only based on height but if it additionally provides the handhold required of a handrail. The user would not otherwise know that the stair rail needs graspability as the provision of 1910.29(f)(5) is written to have applicability to handrails, not specifically to stair rails that are at an appropriate height so as to serve as a handrail (Ex. 97).

OSHA agrees with NFPA that the final standard should only allow employers to use stair rail top rails as handrails if the top rail "has the shape and

dimension necessary so employees can grasp it firmly to avoid falling" (see final paragraph (f)(5)). However, OSHA also believes that employers can use stair rails as handrails only if the stair rails also meet other handrail requirements such as having smooth surfaces (see final paragraph (f)(3)) and no projection hazards (see final paragraph (f)(6)). OSHA revises the final rule accordingly.

Final paragraph (f)(2) requires that employers ensure there is a finger clearance of at least 2.25 inches between handrails (including the top rail of a stair rail system being used as handrails) and any other object (such as a wall). Workers need adequate clearance space so they are able to maintain a firm grasp on the handrail while they go up and down workplace stairs.

The proposed rule would have required a three-inch minimum clearance for handrails and stair rails. OSHA explained that the proposed minimum clearance would make the general industry rule consistent with the construction stairways standard (§ 1926.1052(c)(11)), which also requires a minimum clearance of three inches for handrails that will not be a permanent part of the structure being built.

In 1990, OSHA first proposed revising the existing three-inch finger clearance requirement to a minimum of 1.5 inches. OSHA explained that the revision would make the rule consistent with local building codes; ANSI A12.1–1973, Safety Requirements For Floor and Wall Openings, Railings, and Toeboards; draft revised A1264.1; and ANSI A117.1–1986, Providing Accessibility and Usability for Physically Handicapped People (Ex. OSHA–S041–2006–0666–0054). The A1264.1–2007 (Section 5.9) standard eventually adopted a 2.25-inch minimum finger clearance.

In the 2010 proposal, OSHA said it proposed to retain the existing three-inch minimum clearance so the general industry rule would be consistent with the construction stairways standard, thereby facilitating compliance for employers who perform both general industry and construction activities. OSHA also said the difference between the three-inch minimum clearance in the proposed, existing, and construction standards and the 2.25-inch minimum clearance in A1264.1–2007 was not "significant" (75 FR 28897). Nonetheless, OSHA asked for comment on whether the Agency should adopt the 2.25 inch requirement instead.

NFPA submitted a comment recommending that OSHA adopt a 2.25-inch minimum clearance for handrails,

which the NFPA 101 Life Safety Code requires, for the following reasons:

(1) for consistency among the model codes [which require only a 2.25-inch finger clearance], (2) so that owners/operators are not surprised with a violation after complying with the model codes, and (3) because there is no technical basis for requiring more than 2¼ inches in order to provide a usable handrail. Remember that for years and years the model codes' minimum finger clearance was 1½ inches but concerns over users skinning their knuckles on rough wall surfaces led to research that identified the 2¼ inch criterion as necessary and adequate (Ex. 97).

NFPA also disagreed with the Agency's characterization of the difference between OSHA's existing and proposed three-inch minimum finger clearance and the 2.25 clearance in A1264.1–2007 as "not significant," stating:

Where a 3-inch finger clearance is used for handrails at both sides of a stair in place of a 2¼-inch finger clearance, the stair's rated egress capacity drops by 5 persons. Owners of new buildings want to maximize egress capacity with respect to the space allotted to a stair, and the loss of egress credit for 5 persons is significant. So compliance with the proposed OSHA requirement will add cost (Ex. 97).

With the exception of NFPA's claim that a three-inch clearance will increase building construction costs, OSHA finds convincing NFPA's reasons for recommending a 2.25-inch minimum clearance space. A 2.25-inch minimum finger clearance will make the final rule consistent with NFPA 101 as well as ANSI/ASSE A1264.1–2007, and the International Building Code–2012 (IBC–2012). OSHA believes that following those consensus standards will prevent confusion and ensure the final rule complies with section 6(b)(8) of the OSH Act. In addition, since 2.25 inches is a minimum clearance, employers may continue to use a three-inch clearance. Therefore, OSHA believes the 2.25-inch minimum clearance in the final rule provides greater compliance flexibility for employers.

Final paragraph (f)(3) requires that employers ensure handrails and stair rail systems are smooth-surfaced to protect workers from injury, such as punctures or lacerations, and to prevent catching or snagging of clothing, including protective clothing. OSHA revises the final provision to make it consistent with final (b)(6), for guardrail systems.

The final provision is consistent with the existing rules for stair rails in § 1910.23(e)(3)(v)(a) and handrails in § 1910.23(e)(5)(i), as well as the construction stairways standard in

§ 1926.1052(c)(8). The A10.18–2012 standard (Section 5.2) also contains a similar requirement that stairways “shall be free of sharp edges, splinters, or similar conditions.” OSHA did not receive any comments on the proposed provision and adopts it as discussed.

Final paragraph (f)(4), like the proposed rule, requires that employers ensure no opening in a stair rail system exceeds 19 inches at its least dimension. Final § 1910.21(b) defines “stair rail system” as a barrier erected along the “exposed or open side of stairways to prevent employees from falling to a lower level.” Stair rail systems, like guardrail systems, need to limit the openings in the exposed or open sides of stairways to prevent workers from falling through to a lower level. Limiting the openings also can prevent objects from falling through the opening and hitting workers who are below, although openings that are 19 inches apart may not prevent some objects from falling.

The final provision is consistent with the construction fall protection and stairways standards in §§ 1926.502(b)(2)(iii) and (iv) and 1926.1052(c)(4)(iii) and (iv), respectively, for openings in stair rail and guardrail systems. The existing rule in § 1910.23(e)(1) requires a midrail “approximately halfway between the top rail and the [walking-working surface].” OSHA did not receive any comments on the proposed provision and adopts it as discussed above.

Final paragraph (f)(5), like the proposed rule, requires that employers ensure handrails (including top rails of stair rail systems serving as handrails (final paragraph (f)(1)(iii)), have the shape and dimension necessary so workers can grasp the handrail firmly. The final rule is similar to the construction stairways standard in § 1926.1052(c)(9). The existing rule at existing § 1910.23(e)(5)(i) requires that handrails be of a rounded or other section that furnishes an adequate handhold to avoid falling. Similarly, the A1264.1–2007 standard (Section 5.8) requires that handrails be rounded with a cross sectional design that furnishes an adequate handhold for anyone grasping it to avoid falling. A10.18–2012 (Section 6.3) also requires a handhold to grasp to avoid falling.

OSHA received a comment from NFPA saying the proposed requirement was too vague. In its comment, NFPA stated:

The provision . . . requires someone to judge whether a handrail’s shape and dimensions provide a firm handhold for employees. The requirement is too performance-based without providing guidance as to what is intended with respect

to a ‘firm’ handhold. Its enforcement will be subjective (Ex. 97).

NFPA recommended that OSHA instead adopt the following language on handhold criteria from the NFPA 101 Life Safety Code:

Handrails conforming with one of the following features are deemed to comply with the requirement for handhold: (i) The handrail has a circular cross section with an outside diameter of not less than 1¼ in. (3 cm) and not more than 2 in. (5 cm), or (ii) the handrail has a shape that is other than circular with a perimeter dimension of not less than 4 in. (10 cm), but not more than 6¼ in. (16 cm), and with the largest cross-sectional dimension not more than 2¼ in. (6 cm)(Ex. 97).

OSHA does not believe it is necessary to add to final paragraph (f)(5) the specification language NFPA recommends. Requirements on handrail and stair rail system handholds have been in place for many years, and OSHA is not aware of any employers experiencing difficulties in ensuring handrails, and top rails serving as handrails, are of the size and dimension that provide a handhold that workers can grasp firmly. OSHA also believes that retaining the performance-based language gives employers flexibility to select the shape and size of handrail that will provide the most effective handhold in particular workplace situations. For example, the performance-based language allows employers to take advantage of anthropometric testing and research to select the size and shape of handrails that provide a firm grasp for the broadest range of workers. Although OSHA is not adopting the language NFPA recommends, the Agency notes that employers who install handrails and top rails of stair rail systems that meet the specification of the NFPA 101 Life Safety Code will be in compliance with final paragraph (f)(5).

Final paragraph (f)(6), like the proposed rule, requires that employers ensure the ends of handrails and stair rail systems do not present any projection hazard. OSHA drew the final provision from the existing general industry rule in § 1910.23(e)(5)(i) and the construction stairways standard in § 1926.1052(c)(10). The final rule also is consistent with A1264.1–2007 (Section 5.8).

OSHA believes it is necessary to prevent or eliminate projection hazards so workers do not walk or fall into a protruding handrail or stair rail system and get injured. Projection hazards also can snag or catch workers’ clothing or equipment and cause workers to lose their balance and fall on, or down, the stairway. A fall on a stairway could

seriously injure, or even kill, a worker. OSHA did not receive any comments on the proposed rule and adopts the provision as discussed above.

Final paragraph (f)(7), similar to the proposed rule, requires that employers ensure handrails, and the top rails of stair rail systems, are capable of withstanding, without failure, a force of at least 200 pounds applied in any downward or outward direction within 2 inches of any point along the top edge of the rail.

OSHA believes it is necessary that handrails and top rails on stair rail systems be able to withstand a force of at least 200 pounds to protect workers from falling to a lower level when they lean on or over handrails and top rails, or if they fall against a rail. If handrails and top rails cannot support a 200-pound force, workers could receive serious injuries or die from falling over the open or exposed side of the stairway.

The proposed rule required that handrails and top rails be capable of withstanding the specified test load “without permanent deformation or a loss of support.” The final rule replaces the proposed language with the term “without failure.” Final § 1910.21(b) defines “failure” as a load refusal, breakage, or separation of component parts. It is the point at which the ultimate strength is exceeded which encompasses loss of support. Failure does not include all “permanent deformation,” but rather deformation that reduces the structural integrity or support capability of a part or member. OSHA believes the term “without failure” clearly reflects the type of deformation the final rule addresses. In addition, OSHA uses the term “without failure” throughout the final rule (e.g., final paragraphs (b)(3), (b)(5), (e)(1), and (i)(6)), which should facilitate understanding of the final rule, and help to ensure consistent interpretation of the final rule.

The final rule is almost identical to the construction stairways standard in § 1926.1052(c)(5). The existing general industry rule included strength-criteria requirements (“200 pounds applied in any direction at any point”) for “completed” stair rail systems (see existing § 1910.23(e)(3)(iv)) and handrail mountings (see existing § 1910.23(e)(5)(iv)). Similarly, the A1264.1–2007 standard (Section 5.6.1) specifies that completed railing systems must be able to withstand a concentrated load of 200 pounds “applied in any direction, except up, at the midpoint between posts without exceeding maximum allowable deflection.” OSHA did not receive any

comments on the proposed provision and adopts it with the revised language discussed above.

Paragraph (g)—Cages, Wells, and Platforms Used With Fixed Ladders

Final paragraph (g) establishes criteria and practice requirements for cages, wells, and platforms used with fixed ladders. As discussed above in this preamble, final § 1910.28 limits, and eventually phases out, the use of cages and wells as a means of fall protection on fixed ladders. After the final phase-out deadline, employers must ensure all fixed ladders have ladder safety systems or personal fall arrest systems to protect workers from falling to a lower level. Final paragraph (g) includes an informational note reminding employers that final § 1910.28 establishes the requirements that employers must follow on the use of cages and wells as a means of fall protection. OSHA notes that the requirements in final paragraph (g) do not apply once a ladder safety system or personal fall arrest system has been installed on the fixed ladder as required by final § 1910.28(b)(9).

Final paragraph (g)(1), similar to the proposed rule, requires that employers ensure cages and wells installed on fixed ladders are designed, constructed, and maintained to permit easy access to, and egress from the ladder that they enclose. The final rule divides the other proposed requirements into separate provisions, which makes the final rule easier to understand and follow.

Consistent with the OSH Act (29 U.S.C. 655, 6(b)(5)), final paragraph (g)(1) replaces the specification requirements for cages and wells in existing § 1910.27(d) with performance-based language that specifies the performance objective of the final rule (e.g., to permit easy access and egress). The existing rule, on the other hand, specifies that cages extend down the ladder to a point not less than 7 feet nor more than 8 feet above the base of the ladder, and flare not less than 4 inches at the bottom. The existing rule also requires that the cages extend a minimum of 42 inches above the top of the landing a fixed ladder is served by. OSHA believes that the final rule's performance-based approach also provides flexibility to employers. OSHA includes Figure D-15 in the final rule, which provides an example of acceptable cage construction and dimensions.

Final paragraph (g)(1) adds language specifying that employers ensure cages and wells, in addition to being designed and constructed to provide easy access to and egress from the fixed ladder, are maintained in that condition. This

language reinforces the general maintenance and safe access and egress requirements in final § 1910.22. OSHA did not receive any comments on the proposed rule and adopts the provision with the clarifications discussed above.

Final paragraph (g)(2), like proposed paragraph (g)(1), requires that employers ensure cages and wells are continuous throughout the length of the fixed ladder, except for access, egress, and other transfer points. Requiring that cages and wells cover the entire length of the fixed ladder is necessary to ensure that cages and wells are effective in containing and directing workers to a lower landing.

Final paragraph (g)(2) recasts into plain language two provisions in the existing general industry rule and is consistent with the construction ladder standards that address the length of cages on fixed ladders. Both the existing general industry and construction standards require that cages extend along the fixed ladder to a point that is not less than seven feet nor more than eight feet above the base of the ladder (see existing § 1910.27(d)(1)(iv) and § 1926.1053(a)(20)(vii)). These standards also require that the tops of cages extend at least 42 inches above the top of the platform or the point of access at the top of the ladder (see existing § 1910.27(d)(1)(iii) and § 1926.1053(a)(20)(viii)). A14.3-2008 (Sections 6.1.2.4 and 6.1.2.5) also includes similar requirements. OSHA did not receive any comments on the proposed rule and adopts it with the revised performance-based language discussed above.

Final paragraph (g)(3), similar to proposed paragraph (g)(1), requires that employers ensure cages and wells are designed, constructed, and maintained so they contain workers in the event of a fall and direct them to a lower landing. Like final paragraph (g)(1), and consistent with the OSH Act (29 U.S.C. 655, 6(b)(5)), final paragraph (g)(3) replaces detailed specification requirements in the existing rule in § 1910.27(d) with performance-based language. OSHA believes the performance-based language gives employers greater flexibility in designing, constructing, and maintaining cages and wells than the existing standard. OSHA did not receive any comments on the proposed provisions and finalizes the provision as discussed above.

Final paragraph (g)(4), like existing § 1910.27(d)(2)(ii) and proposed paragraph (g)(2), requires that employers ensure landing platforms used with fixed ladders provide workers with a horizontal surface that is at least 24

inches by 30 inches. The final rule is consistent with ANSI A14.3-2002.

OSHA notes that fixed ladder platforms, like other walking-working surfaces, also must comply with the load requirements in final § 1910.22(b). That is, fixed ladder platforms must be capable of supporting the maximum intended load that employers will impose on them. OSHA did not receive any comments on the proposed requirement and adopts it as discussed.

Paragraph (h)—Outdoor Advertising

Final paragraph (h) establishes temporary criteria and practice requirements for employers engaged in outdoor advertising (billboard) operations (hereafter referred to as "outdoor advertising operations" and "outdoor advertising employers"). As final § 1910.28(b)(9) and (10) specify, and the note to this paragraph reinforces through its reference to § 1910.28, outdoor advertising employers may allow their workers⁷¹ to climb fixed ladders without fall protection until November 19, 2018, which is two years after publication of the final rule. After that date, outdoor advertising employers must provide fall protection in accordance with final § 1910.28(b)(9), Fixed ladders, and the requirements in this paragraph no longer apply.

The effect of final § 1910.28(b)(9) and (10) is to phase out the exception to the fall protection requirements that apply to climbing fixed ladders that OSHA provided in a variance granted in 1991 to Gannett Outdoor (56 FR 8801 (3/1/1991)), and extended to all outdoor advertising operations in a 1993 OSHA directive (Fixed Ladders Used on Outdoor Advertising Structures/Billboards in the Outdoor Advertising Industry, STD 01-01-014 (1/26/1993)) (Ex. 51).

Final paragraph (h) specifies the requirements that apply during the phase out period. OSHA drew the requirements in proposed and final paragraph (h) from the 1993 outdoor advertising directive. OSHA stresses that during the phase out period, outdoor advertising employers must: (1) Ensure workers climbing fixed ladders wear a body harness equipped with an 18-inch rest lanyard (final § 1910.28(b)(10)(ii)(B)); and (2) ensure workers are protected by a fall

⁷¹ The proposed rule in § 1910.21(b) referred to these workers as "qualified climbers," which the proposal defined as workers engaged in outdoor advertising operations who, by virtue of their physical capabilities, training, work experience, and job assignment, the employer authorizes to climb fixed ladders without using fall protection. Since the final rule phases out the use of qualified climbers in two years, on November 19, 2018, OSHA does not use the term in this final rule.

protection system once they reach the work position (final § 1910.28(b)(10)(ii)(D)).

Final paragraph (h)(1), like the proposed rule, requires that outdoor advertising employers ensure that each worker who climbs fixed ladders without fall protection is physically capable to perform those duties that employers may assign. To ensure that workers are physically capable, final paragraph (h)(1) requires that employers either observe workers performing actual climbing activities, or ensure workers undergo a physical examination.

Final paragraph (h)(1) clarifies the proposed rule by making explicit that the determination of a worker's physical capability, whether demonstrated by actual observation of climbing or by physical examination, must include whether workers are physically capable of climbing fixed ladders without fall protection as a regular part of their job duties. OSHA believes the key aspect of physical capability is the ability to climb without using fall protection. Such climbing requires particular strength, agility, and vigilance to prevent falling. Although most employers ensure workers are physically capable to do the job, OSHA believes that the additional language clarifies that the physical examination also must consider whether the worker has the physical ability to climb fixed ladders without fall protection. OSHA added the phrase "including climbing fixed ladders without using fall protection" to the final provision to clarify that one of the duties that workers in the outdoor advertising industry may be assigned is climbing fixed ladders that are not equipped with a ladder safety system or personal fall arrest system. Only after demonstrating the necessary ability and skill in climbing may employers allow workers to climb without using fall protection (see discussion in final § 1910.28(b)(10)).

OSHA received one comment on the proposed provision. Ellis said OSHA should eliminate the outdoor advertising exception "unless medical qualification is added;" however, he did not provide any explanation to support the recommendation (Ex. 155). If Ellis is recommending that physical examinations include a "medical qualification" component, OSHA believes that the vast majority of all standard physical examinations include medical tests. In addition, OSHA believes that appropriate physical examinations to determine physical ability to climb fixed ladders without fall protection include medical tests

such as blood pressure, electrocardiogram, blood, pulmonary, vision, balance, reflex, and other similar medical examinations. As such, OSHA does not believe it is necessary to specify required medical tests in the final rule.

Ellis appears to be recommending that employers must ensure workers have both a physical examination and perform actual climbing activities to demonstrate they are physically capable of climbing fixed ladders without fall protection. OSHA believes the current requirement does not need to be changed because the Agency is phasing out climbing fixed ladders without fall protection. OSHA notes, however, that outdoor advertising employers are free to provide their workers with both a physical examination and have them perform actual climbing activities to demonstrate physical capability.

Final paragraphs (h)(2) and (3) are companion requirements that specify what training employers must provide (final paragraph (h)(2)) and how they must provide it (final paragraph (h)(3)) to ensure workers have the necessary skills to climb fixed ladders without fall protection. OSHA notes that the training outdoor advertising employers must provide in final paragraphs (h)(2) and (3) is in addition to the training they must provide under final § 1910.30.

Final paragraph (h)(2), similar to the proposed rule, requires that outdoor advertising employers ensure their workers who climb fixed ladders without fall protection (1) successfully complete a training or apprenticeship program that includes hands-on training for the safe climbing of ladders, (including fixed ladders without fall protection and portable ladders); and (2) receive retraining as necessary to ensure they maintain necessary skills.

Successful completion of a training or apprenticeship program means workers are proficient in all aspects of the job, including climbing without fall protection. For example, workers who successfully finish their training or apprenticeship program will know at least (1) how to safely transition from fixed ladders to work platforms and portable ladders; (2) the correct angle for safely climbing portable ladders; (3) how to properly attach to ladder safety systems and personal fall arrest systems at certain ladder heights and when transitioning to work platforms; and (4) the impacts of various environmental conditions on safely climbing fixed ladders without fall protection and what action to take. These training tasks address particularly dangerous climbing conditions, and OSHA believes completion of training or an

apprenticeship program is only successful if workers are proficient in these types of tasks. If an employer observes, or has reason to believe, that workers are no longer proficient in climbing fixed ladders without fall protection, final paragraph (h)(2) requires that they provide retraining to restore the worker's proficiency.

OSHA notes that final paragraph (h)(2), like the proposal includes language specifying that employee training on safe climbing must include "hands-on" training. OSHA believes that workers must have opportunities to train on ladders and with the equipment they will use to perform their work (e.g., rest lanyards) in order to become proficient in climbing fixed ladders without fall protection. OSHA did not receive any comments on proposed paragraph (h)(2) and adopts it with only minor editorial change.

Final paragraph (h)(3), like the proposed rule, requires that outdoor advertising employers ensure workers possess the skill to climb ladders safely as demonstrated through:

- Formal classroom training or on-the-job training; and
- Performance observations.

To develop the necessary skills and proficiency to climb fixed ladders without fall protection, OSHA believes that worker training must consist of two components: Formal classroom training or on-the-job training on safe climbing of ladders, and worker demonstration of proficiency of ladder climbing skills. Employers must ensure workers receive formal classroom or on-the-job training, and then are personally observed demonstrating their skills and proficiency before considering a training or apprenticeship program to be "successfully completed." OSHA stresses that workers must successfully complete the training and demonstration of climbing skills and proficiency before employers may allow or assign workers to climb ladders unsupervised as part of their job. The same is true for on-the-job training, which is not "learn as you work" training. The purpose and structure of on-the-job training must be to teach workers and help them develop, through observation and practice, the necessary skills and proficiency to climb fixed ladders without fall protection before assigning them to perform regular climbing jobs unsupervised. OSHA did not receive any comments on the proposed provision and adopts it as discussed above.

Final paragraph (h)(4), like the proposed rule, requires that employers permit workers to climb fixed ladders

without fall protection only if such climbing is part of their routine work activities. As OSHA explained in the preamble to the proposed rule, it is essential that workers regularly perform climbing tasks so they retain knowledge of proper climbing practices and maintain climbing proficiency, including physical capabilities (75 FR 28898).

Ellis recommended eliminating “qualified climbers” unless OSHA requires that employers supervise all climbing on fixed ladders (Ex. 155). OSHA does not believe Ellis’ recommendation is needed. The final rule requires that outdoor advertising workers who climb fixed ladders without fall protection receive extensive training before employers assign them to perform regular climbing activities. That training includes classroom or hands-on training plus observation of worker climbing proficiency. In addition, employers must train those workers in fall and equipment hazards, and provide retraining as necessary (see final § 1910.30). OSHA believes the training requirements in the final rule are adequate to ensure that outdoor advertising workers have the skills necessary to climb fixed ladders unsupervised without fall protection during the phase-out period. Therefore, OSHA did not adopt the commenter’s recommendation.

Paragraph (i)—Ladder Safety Systems

Final paragraph (i) establishes criteria and practice requirements for ladder safety systems permanently attached to fixed ladders or immediately adjacent to such ladders. A ladder safety system is a system designed to eliminate or reduce the possibility of falling from a ladder (see definition of “ladder safety system” in final § 1910.21(b)). According to this definition, it usually consists of the following:

- A carrier, also called “a lifeline,” which is a rigid or flexible track attached to or adjacent to the fixed ladder;
- A safety sleeve, which is moving component that travels on the carrier;
- A lanyard;
- Connectors; and
- A body harness.

Although the existing rule (§ 1910.21(e)(13)) defines “ladder safety devices,” which serve the same purpose as ladder safety systems, the existing rule does not specify criteria or practice requirements for those devices. As a result, OSHA drew many of the proposed ladder safety system criteria and practice requirements from the construction ladder standard

(§ 1926.1053(a)(22) and (23)).⁷² OSHA also drew ladder safety system criteria and practice from A14.3–2008.

Final paragraph (i)(1) requires that employers must ensure each ladder safety system allows workers to climb up and down the fixed ladder with both hands free for climbing. The final rule also specifies that the design of the ladder safety system must be such that it does not require that workers continuously hold, push, or pull any part of the system while they are climbing. Final paragraph (i)(1) is consistent with the construction ladder standard in § 1926.1053(a)(22)(ii) and A14.3 (Section 7.3.1).

In commenting on the proposed rule, NGS pointed out:

Some forms of ladder safety systems (*i.e.* rope grabs) may require the employee to periodically hold up a lever to adjust the position of the grab on the rope. This is not continual and the employee can make this adjustment while in a stationary position on the ladder. Once the grab is re-positioned, the employee can climb before stopping and re-adjusting the grab (Ex. 180).

The purpose of the proposed provision was to ensure that the ladder safety system allows workers to use both hands while they are in the process of climbing up and down the fixed ladder; it does not prohibit them from using their hands to position or adjust components of the ladder safety system, such as rope grabs, while stopping and standing in place at certain points along the ladder. OSHA believes the ladder safety system lanyard will protect workers from falling to a lower level in these situations; however, their hands must be free when they resume climbing. The final rule clarifies the provision by adding the term “continuously” in place of “continually.” OSHA believes this change reinforces clearly that workers need to hold onto the ladder with both hands while climbing, but they may perform tasks when they stop climbing.

Final paragraph (i)(2), like the proposed rule, requires that employers ensure the connection between the carrier or lifeline and the point of attachment to the body harness or belt does not exceed 9 inches in length. The purpose of this provision is to limit the length of any fall and resulting arrest forces. The final rule ensures that no fall exceeds 18 inches, which will limit the arresting forces. The final rule is almost identical to the construction ladder standard in § 1926.1053(a)(22)(iv). The A14.3–2008 standard (Section 7.3.3)

⁷² The construction standard allows the use of body harnesses or body belts with ladder safety systems.

also limits the lanyard length to 9 inches.

Ellis commented that OSHA should prohibit the use of body belts with ladder safety systems, and pointed out that the A14.3–2008 standard specifies harnesses instead of body belts as part of a ladder safety system (Ex. 155). He added that “[a]ll manufacturers have changed at this stage to harness[es] for this climbing device” (Ex. 155). OSHA agrees that most employers provide body harnesses for use with ladder safety systems because harnesses distribute arresting forces across a broader portion of the body, which makes them safer than body belts. However, since the final rule limits the lanyard length to 9 inches, the maximum free fall will be 18 inches. OSHA believes a maximum free fall of 18 inches will not put an excessive arresting force on workers even if they are using body belts instead of harnesses. As such, like the construction ladder standard, OSHA does not believe it is necessary to prohibit the use of body belts with ladder safety systems.

Final paragraph (i)(3), like the proposed rule, requires employers to ensure that mountings for rigid carriers are attached at each end of the carrier, with intermediate mountings spaced, as necessary, along the entire length of the carrier so the system has the strength to stop worker falls. The requirements in the final rule are consistent with the construction ladder standard (§ 1926.1053(a)(23)(i)). The A14.3–2008 standard (Section 7.3.4) also requires that rigid carriers on ladder safety systems have mountings at the end of each carrier and intermediate mountings along the carrier. However, that standard establishes specification requirements for intermediate mountings instead of the performance-based language in the final rule. A14.3–2008 requires intermediate mountings spaced along the carrier in accordance with manufacturer’s recommendations, and installed within one foot below each splice on the carrier, with at least one mounting every 25 feet.

The purpose of final paragraph (i)(3) is to ensure the ladder safety system carrier remains in place and supports the worker, if a fall occurs, by attaching the carrier (or lifeline) firmly to the fixed ladder throughout the length of the ladder. To ensure that the carrier has the strength necessary to hold a falling worker, the final rule requires that employers install an adequate number of mountings spaced “as necessary” along the entire carrier length. OSHA believes that manufacturer’s instructions likely identify the number

and spacing of intermediate mountings they believe are necessary to firmly secure the carrier. However, some carriers may need additional mountings to ensure they are able to support the arresting forces of a falling worker. For example, as the standard indicates, if a carrier consists of several sections, employers may need to use additional intermediate mountings. Therefore, the final rule requires that employers put intermediate mountings at those places along the carrier (e.g., by any splice on the carrier) where they are necessary to ensure the carrier has the strength to stop workers from falling to a lower level. OSHA believes requiring that employers install and space the mountings “as necessary” will ensure that employers inspect and evaluate where intermediate mountings are needed when they install ladder safety systems. OSHA did not receive any comments on the proposed provision and adopts it as explained above.

Final paragraph (i)(4), similar to the proposed rule, requires that employers ensure flexible carriers have mountings attached at each end of the carrier. The final rule also requires the installation of cable guides for flexible carriers at least 25 feet apart, but not more than 40 feet apart, along the entire length of the carrier. The final rule is consistent with both the construction ladder standard (§ 1926.1053(a)(23)(ii)) and A14.3–2008 (Section 7.3.5). The purpose of the requirement is to ensure the system has the strength necessary to stop worker falls and, as the construction ladder standard indicates, to prevent wind damage to the ladder safety system and its components. OSHA did not receive any comments on the proposed provision and finalizes it with the clarifications discussed above.

Final paragraph (i)(5), like the proposed rule, reinforces final paragraphs (i)(3) and (i)(4) by requiring employers to ensure that the design and installation of mountings and cable guides do not reduce the design strength of the ladder. The final rule is consistent with both the construction ladder standard in § 1926.1053(a)(23)(iii) and A14.3–2008 (Section 7.1.4). OSHA did not receive any comments on the proposed provision and adopts it with a minor change for clarity.

Final paragraph (i)(6), like the proposed rule, requires that employers ensure ladder safety systems and their support systems are capable of withstanding, without failure, a drop test consisting of an 18-inch drop of a 500-pound weight. This drop test, therefore, must arrest and suspend the 500-pound weight without damage to or failure of the ladder safety system and

its support system and without the test weight hitting a lower level (such as the ground). The final rule is consistent with both the construction ladder standard in § 1926.1053(a)(22)(i) and A14.3–2008 (Section 7.1.3).

Ellis recommended that the final rule include a test to determine whether horizontal thrust will cause the ladder safety system to fail (Ex. 155). He also recommended that the final rule incorporate the program of eight tests Great Britain’s Health and Safety Executive established. OSHA notes the A14.3 Committee did not adopt those tests, and footnote 7 in the A14.3–2008 standard states there is no scientific determination currently available (in 2008) on this issue to support any action. Ellis did not provide any evidence to support adopting his recommendation.

Ameren recommended that OSHA only require that employers comply with the ladder safety systems criteria and practice requirements when they install new or replacement fixed ladders and ladder safety systems, stating, “It could very easily be financially burdensome for an employer to replace safe, operating systems to meet proposed requirements” (Ex. 189). The final rule basically follows the approach Ameren recommends. The final rule (final § 1910.28(b)(9)) does not require that employers immediately install ladder safety systems (or personal fall arrest systems) on existing fixed ladders (i.e., ladders installed before November 19, 2018) that have a cage or well. The final rule requires those employers to install a ladder safety system or personal fall arrest system: (1) When the employer replaces the fixed ladder or a section of it; or (2) by November 18, 2036, which is the final deadline for installing ladder safety systems (or personal fall arrest systems) on all fixed ladders.

Paragraph (j)—Personal Fall Protection Systems

Final paragraph (j), like the proposed rule, requires that body belts, body harnesses, and other components used in personal fall arrest systems, work positioning systems, and travel restraint systems, meet the applicable requirements in final § 1910.140. The final § 1910.140 preamble discusses the criteria and practice requirements for those personal fall protection systems, and addresses stakeholder comments.

Paragraph (k)—Protection From Falling Objects

As discussed earlier in this preamble, the final rule in § 1910.28(c) requires that employers protect workers from

being hit by falling objects by keeping objects, including tools, materials, and equipment, far enough away from the exposed edge to prevent them from falling to a lower level, and by using one or more of the following falling object protection measures: (1) Toeboards, screens, or guardrail systems; (2) canopy structures; or (3) barricading the area and prohibiting workers from entering the barricaded area.

Final paragraph (k) establishes criteria and practice requirements for the measures that final § 1910.28(c) requires. The existing rule in § 1910.23(e)(4) contains limited requirements for toeboards and guardrails, and OSHA drew criteria and practice requirements for these measures from the construction fall protection standard in § 1926.502(j), A10.18–2012 (Section 4.1.5), and A1264.1–2007 (Section 5.7).

Final paragraph (k)(1) establishes criteria and practice requirements for toeboards, which the final rule in § 1910.21(b) defines as a low protective barrier that is designed to prevent materials, tools, and equipment from falling to a lower level. The final definition also specifies that toeboards protect workers from falling to a lower level.

Final paragraph (k)(1)(i), similar to proposed paragraph (k)(1), requires that employers ensure toeboards, when used for falling object protection, are erected along the exposed edge of the overhead walking-working surface for a length that is sufficient to protect workers below. In determining how much of the walking-working surface must have toeboards, employers not only must provide toeboards where objects are placed or piled, but also take into account that objects may move or roll on a walking-working surface before going over an exposed edge. In addition, employers must consider where employees may be working on a lower level. The final rule is consistent with the construction fall protection standard in § 1926.502(j)(1). OSHA did not receive any comments on the proposed provision and adopts it as proposed, with minor editorial revisions.

Final paragraph (k)(1)(ii), like proposed paragraph (k)(2)(i), requires that employers ensure the minimum vertical height of toeboards is 3.5 inches, as measured from the top edge of the toeboard to the level of the walking-working surface. The existing rule in § 1910.23(e)(4) requires a four-inch nominal vertical toeboard height, but does not indicate the permissible deviation from that height. However, to make the provision consistent with the construction fall protection standard,

OSHA proposed and adopts a 3.5-inch minimum vertical toeboard height. The final rule also is consistent with A1264.1–2007 (Section 5.7) and A10.18–2012 (Section 4.1.5).

OSHA stresses that, like the construction fall protection standard in § 1926.502(j)(3), the required 3.5-inch toeboard height is the minimum height. If employers have objects or materials near the toeboard that are higher than the toeboard, they must ensure the toeboard height is sufficient to prevent the objects from falling over the edge to a lower level, as specified in final paragraph (k)(2). OSHA notes that when objects are piled higher than the toeboard, final paragraph (k)(2) requires employers to erect guardrail systems that have paneling or screening installed from the top edge of the toeboard to the top rail or midrail of the guardrail system. (See further discussion of final paragraph (k)(2) below.) OSHA did not receive any comments on the proposed requirement and finalizes it as discussed above.

Final paragraph (k)(1)(iii), similar to existing § 1910.23(e)(4) and proposed paragraph (k)(2)(i), requires that employers ensure toeboards do not have an opening or clearance of more than 0.25 inches above the walking-working surface. This is measured from the walking-working surface to the bottom of the toeboard. The purpose of this requirement is to ensure that objects cannot fall off the walking-working surface through any drainage openings in the toeboard. The final rule is consistent with the construction fall protection standard (§ 1926.502(j)(3)), A10.18–2012 (Section 5.7), and A1264.1–2007 (Section 4.1.5).

Final paragraph (k)(1)(iv) is a companion provision to final paragraph (k)(1)(iii). Like proposed (k)(2)(i), it requires that employers ensure toeboards are solid or, if they have openings, the openings do not exceed 1 inch at their greatest dimension. OSHA acknowledges that the toeboards employers use in outdoor work areas may need drainage openings to prevent water from collecting on the walking-working surface, resulting in slips and falls. Therefore, this provision, along with final paragraph (k)(1)(iii), requires employers to ensure that such drainage openings do not exceed a height of $\frac{1}{4}$ inch or a length of 1 inch. These provisions are substantively the same as the proposed language. However, the final rule (paragraphs (k)(1)(iii) and (iv)) simplifies and clarifies the proposed provision. The final rule separates the requirements into two provisions, which makes them easier to understand, and removes unnecessary language (e.g.,

“vertical”). The final rule also clarifies the requirements by specifying more clearly than the proposal that no opening in the toeboard shall exceed 1 inch in length (final paragraph (k)(1)(iv)) and 0.25 inches in height (final paragraph (k)(1)(iii)). These maximum dimensions will ensure that objects cannot fall through any opening in a toeboard.

OSHA did not receive any comments on the requirements in proposed paragraph (k)(2)(i) and adopts final paragraphs (k)(1)(iii) and (iv) as discussed above.

Final paragraph (k)(1)(v), like proposed paragraph (k)(2)(ii), requires that employers ensure toeboards used around vehicle repair, service, and assembly pits (pits) have a minimum height of 2.5 inches. The height is measured from the walking-working surface to the top edge of the toeboard. The final rule also includes an exception, which specifies that employers do not have to erect toeboards along the exposed edges of a pit if they can demonstrate the toeboard would prevent access to a vehicle that is over the pit.

The final rule recognizes that shorter toeboards are adequate to protect workers from being hit by falling objects when vehicles are over the pit because the space between the toeboard and the vehicles is small enough to prevent most objects from falling into the pit. When vehicles are not over the pit, toeboards are not necessary because employees are not working in the pit and, thus, not exposed to a falling object hazard. Therefore, the exception is necessary because toeboards, even short ones, would prevent workers from accessing the vehicle to perform repair, service, or assembly work.

The final rule clarifies the proposed toeboard exception in two respects. First, the final rule states more clearly than the proposal that the toeboard exception applies only when “employers can demonstrate” that erecting toeboards would prevent access to a vehicle. In the preamble to the proposal, OSHA explained that employers have the duty to show that toeboards would prevent vehicle access (75 FR 28899). The final rule adds that language to the regulatory text to clarify this requirement.

Second, the final rule clarifies that the exception is limited. It only applies to those parts and sections of exposed edges where erecting toeboards would prevent access to a vehicle that is over a pit. The final rule still requires that employers erect toeboards at other exposed edges. OSHA did not receive any comments on the proposed

provision and exception, and finalizes them with the clarifications explained above.

Final paragraph (k)(1)(vi), like proposed paragraph (k)(4), requires that employers ensure toeboards are capable of withstanding, without failure, a force of at least 50 pounds, applied in any downward or outward direction at any point along the toeboard. OSHA drew the requirement from the construction fall protection standard in § 1926.502(j)(2). The existing rule in § 1910.23(e)(4) does not include this requirement; rather, the existing provision specifies that employers securely fasten toeboards and they be made of “any substantial material.”

As defined in final § 1910.21(b), “failure” means a load refusal (*i.e.*, the point at which the load exceeds the ultimate strength of a component or object), breakage, or separation of component parts. Therefore, “without failure” means a toeboard must have adequate strength to remain in place and intact after applying 50 pounds in a downward or outward direction at any point along the toeboard. OSHA believes that the language in final rule and the construction fall protection standard is clearer, and provides employers with better guidance on compliance, than the existing rule. OSHA did not receive any comments on the proposed requirement and finalizes it as discussed above.

Final paragraph (k)(2)(i), like proposed (k)(3), establishes criteria and practice requirements where tools, equipment, or materials are piled higher than the toeboard. Where such items are piled higher than the toeboard, the employer must install paneling or screening from the toeboard to the midrail of the guardrail system and for a length that is sufficient to protect employees below. If the items are piled higher than the midrail, the employer must install paneling or screening to the top rail of the guardrail and for a length that is sufficient to protect employees below.

The final provision uses the same approach as the construction fall protection standard in § 1926.502(j)(4) when objects are piled higher than the toeboard. The construction standard requires that employers install paneling or screening from the walking-working surface or toeboard to the top of the guardrail or midrail. In addition to requiring that employers use guardrail systems in such cases, final § 1910.28(c)(2) requires that employers must protect workers from falling objects by keeping objects far enough from the exposed edges to prevent them from falling to a lower level. OSHA

believes that this two-pronged approach provides effective redundancy that will prevent falling objects from injuring or killing workers on lower levels. In addition, OSHA believes that following a similar approach to that in the construction standard will make compliance easier for employers who perform both general industry and construction activities.

OSHA notes final paragraph (k)(2)(i) requires that employers use guardrail systems equipped with “paneling or screening” rather than vertical members specified in final § 1910.29(b). Even though the final rule requires that the distance between vertical members must not exceed 19 inches, OSHA believes that some items, such as heavy tools, can fall through those openings. Paneling, such as solid paneling, or screening will prevent piled objects from falling through the guardrail system to a lower level.

Final paragraph (k)(2)(i), like proposed paragraph (k)(5), also requires that employers ensure the paneling or screening they install extends for a distance along the guardrail system that is sufficient to protect workers below from falling objects. The final rule is consistent with the guardrail requirement in final paragraph (b)(2) of this section, and the construction fall protection standard in § 1926.502(j)(4). Final paragraph (k)(2)(i) also is consistent with existing § 1910.23(e)(4). The A1264.1–2007 standard (Section 5.7) allows employers to use guardrail systems equipped with screening or additional toeboards, to protect workers from falling objects.

Final paragraph (k)(2) consolidates into one provision the proposed criteria and practice requirements for guardrail systems used as falling object protection (see proposed paragraphs (k)(3) and (5)). OSHA believes this consolidation makes the final rule easier to understand and follow than the proposal.

OSHA notes that, except when specified elsewhere, guardrail systems used for falling object protection also must meet the guardrail requirements in final paragraph (b) of this section, such as the strength requirements for paneling and screening (see final paragraph (b)(5)).

OSHA received one comment on the proposed rule. Ellis supported the proposed requirement to install barriers to prevent objects from falling through openings (Ex. 155). He also recommended that materials used for paneling or screening include sheet metal, gratings, and netting (Ex. 155). OSHA notes that A1264.1–2007 (Section 5.7) requires that paneling or screening used for falling object protection have at

least 18-gauge thickness. Although the final rule uses performance-based language, OSHA notes that paneling or screening that meets the ANSI/ASSE standard would comply with final paragraph (k)(2).

Final paragraph (k)(2)(ii), like proposed paragraph (k)(5), requires that employers ensure openings in guardrail systems are small enough to prevent objects from falling through the openings. The final rule is consistent with the construction fall protection standard in § 1926.502(j)(5). OSHA is adopting the proposed rule with only minor editorial change.

Final paragraph (k)(3) establishes requirements for using canopies as falling object protection. Like proposed paragraph (k)(6), the final rule establishes a performance-based provision requiring that employers ensure canopies are strong enough to prevent collapse and penetration when struck by any falling object. The final rule adds language clarifying that the strength requirements in final paragraph (k)(3) only apply to canopies that employers use to protect workers from falling objects, not to all canopies. OSHA did not receive any comments on the proposed measure and finalizes the provision with the editorial change discussed above.

Paragraph (l)—Grab Handles

Final paragraph (l) specifies criteria and practice requirements for grab handles that employers provide, such as at a hoist area. Workers often use grab handles when they lean through or over the edge of the access opening to facilitate hoisting operations. The final rule in § 1910.21(b) defines a “hoist area” as any elevated access opening to a walking-working surface through which equipment or materials are loaded or received.

The final rule does not retain a portion of proposed § 1910.28(b)(2)(ii), which required that employers provide a grab handle on each side of the access opening at hoist areas whenever guardrail systems, gates, or chains are removed to facilitate a hoisting operation and a worker must lean through the opening or over the edge of the access opening. However, if employers do provide grab handles, final paragraph (l) requires that they must ensure the grab handles meet the criteria and practice requirements in final paragraph (l). The existing rule requires that employers provide grab handles on each side of wall openings and holes, and on “extension platforms onto which materials can be hoisted for handling” (see existing § 1910.23(b)(1)(i) and (ii)), and also establishes criteria

that wall opening grab handles must meet (see existing § 1910.23(e)(10)). Neither the construction fall protection standard in § 1926.501 nor any national consensus standard requires the use of grab handles at hoist areas.

OSHA decided to retain the criteria and practice requirements in final paragraph (l) to clarify that employers who provide grab handles must ensure those handles are safe and effective. Moreover, retaining the criteria and practice requirements addresses Ameren’s recommendation that OSHA explain what qualifies as a grab handle in the final rule, requesting that OSHA “be specific as to not cause confusion or misinterpretation” (Ex. 189).

Final paragraph (l)(1), like the proposed rule, requires that grab handles employers provide must be at least 12 inches in length. This final provision is consistent with the existing rule in § 1910.23(e)(10). OSHA believes that 12-inch handles will provide workers with an adequate grip space.

Final paragraph (l)(2), similar to existing § 1910.23(e)(10) and the proposed rule, specifies that grab handles employers install at hoist access openings must provide at least three inches of clearance from the framing or opening. OSHA believes a three-inch clearance is essential to ensure workers have adequate space to wrap their hands around the handle and grip it firmly, if they lean out of the opening during hoisting operations, thereby preventing falls.

Final paragraph (l)(3), like the proposed rule, specifies that grab handles employers provide must be capable of withstanding a maximum horizontal pull-out force equal to two times the maximum intended load or 200 pounds, whichever is greater. The existing rule in § 1910.23(e)(10) has similar language requiring that grab handles be capable of withstanding 200 pounds applied horizontally at any point along the handle. OSHA believes the required strength criteria will ensure that grab handles remain in place when workers hold onto them and lean their bodies out of an access opening. OSHA is adopting final paragraph (l) with the clarifications discussed.

Section 1910.30 Training Requirements

Final § 1910.30, like the proposed rule, adds training requirements to 29 CFR part 1910, subpart D (subpart D). OSHA drew most of the new training requirements from the construction fall protection standard (29 CFR 1926.503). Final § 1910.30 requires training on fall and equipment hazards and, in certain situations, retraining. The final training

requirements are performance based, and give employers flexibility to tailor the requirements and training methods to their workforce and workplace.

Some commenters said that employers are not providing fall protection training, which puts employees at significant risk of injury (Exs. 329 (1/19/2011, p. 86); 329 (1/20/2011, p. 99)). One worker testified that he received no training at any company where he worked, saying, "It was learn as you go" (Ex. 329 (1/19/2011, p. 86)).

OSHA believes that the new training requirements are necessary, and effective worker training is one of the most critical steps employers can take to prevent employee injuries and fatalities. Generally, commenters supported adding training requirements to subpart D (Exs. 53; 73; 96; 127; 172; 189; 205; 216; 222; 226; 329 (1/19/2011, pgs. 22, 24); 364). For example, the AFL-CIO said, "[T]raining requirements are necessary to ensure that workers can identify the fall hazards they face in their workplaces and understand how they can be protected" (Ex. 172). The American Society of Safety Engineers (ASSE) agreed, saying, "[A]ppropriate training is a key element of managing every kind of workplace safety risks" (Ex. 127).

The National Grain and Feed Association (NGFA) stated, training "programs are vital, first and foremost, to safeguard lives and prevent injuries" (Ex. 329 (1/20/2011, p. 248)). Sam Terry, president of Sparkling Clean Window Company, and Dana Taylor, executive vice president of Martin's Window Cleaning, also stressed that proper training is critical to reduce workplace injuries and illnesses (Exs. 222; 362). Mr. Terry said, "The lack of proper training is probably the most significant contributor to accidents and incidents when suspended work is performed" (Ex. 362). He added that most, if not all, of the accidents involving rope descent systems and suspended scaffolding since 1977 that he reviewed "could have been prevented if the employees had received proper training" (Ex. 163). Similarly, Mr. Russell Kendzior, president of the National Floor Safety Institute (NFSI), stated, "Approximately 8 percent of all slips, trips and falls are directly caused by improper or lack of employee training" (Ex. 329 (1/21/2011, p. 204)). The International Window Cleaning Association (IWCA), which has spent years researching and analyzing accident data and industry practices, told OSHA that "inadequate training" was one of the leading causes of accidents among window cleaners (Ex. 364).

Some commenters, however, opposed the proposed training requirements. Mr. Charles Lankford, of Rios & Lankford International Consulting, opposed the application of some training requirements because they do not exempt employers who rely exclusively on guardrails or safety net systems. He said, "[Those] systems . . . are completely passive in their protective characteristics and do not require any special knowledge on the part of the protected employees" (Ex. 368). OSHA does not agree with the commenter. Regardless of whether a fall protection system is passive, it will be effective only if it is installed, inspected, used, maintained, and stored properly and safely. OSHA believes that workers need special and specific knowledge to perform these tasks correctly. For example, to ensure that safety net systems protect employees in the event of a fall, employees must know, or be able to calculate, how much weight the net will hold in the particular situation. Therefore, OSHA believes that workers who use any type of fall protection system must receive proper training. (See discussion of final paragraph (b)(1) for additional explanation.)

The National Chimney Sweep Guild (NCSG) opposed the proposed training requirements for workers who use personal fall protection systems, saying that they duplicated and overlapped the personal protective equipment (PPE) training that § 1910.132(f) requires:

This would place an inappropriate and unnecessary burden on employers, employees and compliance personnel in sorting out the confusion presented by the redundant, overlapping and varying provisions addressing the same issues. Furthermore, unless the rule would allow sweeps to receive generic hazard training (rather than site-specific training), this requirement would be economically infeasible for sweeps (Ex. 150).

As explained in the proposal, OSHA acknowledges that some of the training requirements in § 1910.30 may overlap those in § 1910.132. To the extent that any provisions do overlap, OSHA does not believe that it burdens employers because training that complies with one standard satisfies the employer's obligation under the other standard. That said, OSHA believes that the training requirements in final §§ 1910.30 and 1910.132(f) complement each other and, therefore, ensure that workers receive comprehensive training. For example, final § 1910.30(a)(3)(i) requires that employers train workers how to recognize the need for PPE while § 1910.132(f)(1)(i) requires that employers train employees to know what PPE is necessary and fits. Also,

§ 1910.30(a)(iii) requires that employers train workers in the correct and safe use of personal fall protection systems, while § 1910.132(f)(1)(iv) requires training on the limitations of those systems.

The final rule does not require that training be site-specific; that is, provided the site where employees are performing the job. However, to be effective the training that employers provide needs to address the hazards which their employees may be exposed. OSHA believes that NCSG already may be providing this training. For example, NCSG said they provide shop classes at individual businesses as well as on-the-job training. In addition NCSG said the chimney sweep training program lasts six to 12 months and during that training workers are "exposed to a lot of different situations" (Ex. 329 (1/18/2011), p. 274).

Commenters also supported OSHA's performance-based approach to the training requirements. For example, the National Cotton Ginners' Association (NCGA) (Ex. 73) and the Texas Cotton Ginners' Association (TCGA) (Ex. 96) both said, "We believe it is most beneficial to keep this section general so that each employer may review their own operation to determine which employees need to receive specific training."

Paragraph (a)—Fall Hazards

Final paragraph (a), like the proposed rule, contains training requirements related to fall hazards.⁷³ Final paragraph (a)(1), like the proposal, requires that employers train each employee who uses a personal fall protection system. Final § 1910.21(b) defines personal fall protection system as "a system an employee uses to provide protection from falling or to safely arrest an employee's fall if one occurs." Personal fall protection systems include personal fall arrest, travel restraint, and positioning systems (§ 1910.21(b)).

Final paragraph (a)(1) also requires that employers train each worker required to receive training under subpart D. Subpart D requires worker training in several situations, including:

- When employees use a rope descent system (RDS) (§ 1910.27(b)(2)(iii));
- When employees work on an unguarded working side of a platform

⁷³ The final rule defines fall hazard as "any condition on a walking-working surface that exposes an employee to a risk of harm from a fall on the same level or to a lower level" (final § 1910.21(b)). However, for the purposes of final paragraph (a), "fall hazards" refers to the risk of falling four (4) feet or more to a lower level, except for falling into or onto dangerous equipment; for this exception, there is no limit to the distance an employee may fall to a lower level.

used on slaughtering facilities, loading racks, loading docks, or teeming platforms (§ 1910.28(b)(1)(iii)(C) and (b)(14)(ii)(C)); and

- When employees operate motorized equipment on dockboards not equipped with fall protection (e.g., guardrails) (§ 1910.28(b)(4)(ii)(C)).

In the proposed rule, OSHA invited comment on whether the final rule should expand the scope of the fall hazard training in paragraph (a)(1) to cover all fall hazards over four feet (including ladders); training on the safe use of ladders; and training to avoid slips, trips, and falls on the same level of a walking-working surface (75 FR 28900). Some commenters urged OSHA to expand the scope of the training requirements. For instance, Mr. Bill Kojola of the AFL-CIO said, “It is our view that the training requirements in the final rule need to be expanded to include training for all workers exposed to fall hazards over 4 feet (including those using ladders), those using portable guardrails, and for all workers using portable and fixed ladders” (Ex. 172; see also Ex. 329 (1/20/2011, p. 221)). He pointed out that the construction fall protection standard (§ 1926.503(a)(1)) requires that employers train each employee “who might be exposed to fall hazards,” noting further that “[i]f OSHA is committed to harmonizing its fall protection standards across industries . . . it needs to expand the final [rule] . . . and provide training for all workers who are exposed to fall hazards” (Ex. 172).

Mr. Kojola also urged OSHA to expand training to cover “the hazards of falls on the same level” (Ex. 363). He cited the testimony of Mr. Kendzior (NFSI) who said that the current annual cost of falls to the same level “tops more than 80 billion dollars a year” (Ex. 363, citing Ex. 329 (1/21/2011, p. 201)).

The American Federation of State, County and Municipal Employees (AFSCME) also supported expanding the scope of paragraph (a)(1), stressing the importance of training for employees who use ladders:

Training should not be limited to workers who used a specific fall protection system. All workers should have hazard recognition training that includes prevention of falls from any height or surface. Because ladders are so common in the workplace, they are often considered “safe.” Yet many incident reports include injuries or near misses using a ladder. Any worker who is required to use a ladder in his/her work duties should get basic information on use, care, and limitations of ladders (Ex. 226).

Ellis Fall Safety Solutions also supported adding ladder training to the final rule (Ex. 155).

On the other hand, some commenters opposed expanding the scope of the training requirements. NCGA and TCGA both said:

It is a difficult task to predict where falls may occur in an individual operation and it becomes an insurmountable task to predict where falls are most likely to occur on a general industry basis. Having a more prescriptive list of instances in this section may lead an employer to focus on the list, rather than focusing on the areas of highest risk in his individual facility (Exs. 73; 96).

After analyzing the comments and other information in the record, OSHA decided to adopt the proposed fall hazard training scope without substantive change. For several reasons, OSHA believes that the scope of final paragraph (a)(1) is appropriate, and it is not necessary to expand the paragraph’s scope. First, the scope of final § 1910.30(a)(1) is broad. It requires that employers train all workers who use personal fall arrest systems, travel restraint systems, and positioning systems. The final rule, like the proposal, gives employers great flexibility in selecting what type of fall protection system to use, and OSHA believes that many employers will use personal fall protection systems to protect their workers from fall hazards.

Second, in addition to the workers who must receive training under final paragraph (a)(1), final § 1910.30(b) requires that employers also train each worker who uses equipment covered by subpart D in the proper use, inspection, care, maintenance, and storage of that equipment. The equipment includes, but is not limited to, ladder safety systems, safety net systems, portable guardrails, and mobile ladder stands and platforms. Thus, as AFL-CIO, AFSCME, and other commenters recommended, employers must train each worker who uses fixed ladders equipped with ladder safety systems so they know the proper use, inspection, care, maintenance, and storage of that equipment.

Third, employees are also protected by the inspection, control, work practice, and design requirements in subpart D. For instance, final § 1910.23 specifies many design and work practice requirements for portable ladders. Under the final rule, employers are responsible for providing portable ladders that comply with the design requirements, as well as for ensuring that their workers understand and follow the work practices in § 1910.23. OSHA believes that the measures in the final rule, taken as a whole, establish an effective plan to protect workers from slip, trip, and fall hazards.

In final paragraph (a)(1), OSHA added language to clarify the date by which employers must train workers who use personal fall protection systems or who are required to be trained on fall hazards as specified elsewhere in subpart D. Additionally, the Agency added language to the final rule requiring employers to train workers before the worker can be exposed to the fall hazard. As noted in the preamble to the proposed rule, OSHA intended to include this language in the regulatory text (75 FR 28899). Accordingly, employers must train their current workers after OSHA publishes the final rule, and train newly-hired workers before initially assigning them to a job where they may be exposed to a fall hazard. To give employers adequate time in which to develop and provide initial training, OSHA is allowing employers six months, on or before May 17, 2017, to train their workers in the requirements specified in § 1910.30(a).

Edison Electric Institute (EEL) said OSHA should not require employers to provide initial training if they have previously trained workers:

The proposed regulation should allow employers to consider previously delivered training as compliant. Employers should not be required to retrain employees just because the new regulation is finalized. Work practices by many employers will not be changed by the new regulation and they should not be required arbitrarily to retrain employees (Ex. 207).

OSHA agrees with EEL’s comment. An employer whose workers have received training, either from the employer or another employer, that meets the requirements of final § 1910.30(a) will not need to provide additional initial training. However, many of the training requirements in final § 1910.30 are new, and if the initial training workers already have received does not meet all of the requirements in the final rule, employers will need to provide initial training on those requirements.

OSHA does not think the requirement to provide training for workers whose previous training does not meet the final rule or to provide initial training for new workers will pose significant difficulties for employers. Many commenters said that they train workers annually or continually (Ex. 329 (1/19/2011, pgs. 25, 45, 240, 413); 329 (1/20/2011, p. 284)). Since the final rule allows employers six months to provide initial training that complies with final § 1910.30, OSHA believes that most employers will be able to work the required training into their existing annual or continuing training schedule.

Finally, in final paragraph (a)(1), OSHA deleted the second sentence of

the proposed paragraph, and moved to it to final paragraph (a)(3). That sentence specified topics that training must cover (*i.e.*, recognize the hazards of falling and understand the procedures to be followed to minimize the hazards), and OSHA believes it is most appropriate to group these topics with the other training topics in final paragraph (a)(3).

Final paragraph (a)(2), like the proposed rule, requires that employers ensure a qualified person trains each worker in the requirements specified in § 1910.30(a). Final § 1910.21(b) defines “qualified” as a person who, by possession of a recognized degree, certificate, or professional standing, or who by extensive knowledge, training, and experience has successfully demonstrated the ability to solve or resolve problems relating to the subject matter, the work, or the project. OSHA believes that having a person who has a degree, certificate, or professional standing (hereafter “degree”) or extensive knowledge, training, and experience (hereafter “extensive knowledge”) in fall hazards, and who demonstrates ability to solve problems related to fall hazards, will help to ensure that employees receive effective training. Moreover, to stress the importance of this requirement and its application to all the training that § 1910.30 requires, OSHA made a separate provision for this requirement in the final rule.

OSHA notes that the construction fall protection standard, instead of specifying that a qualified person must train workers, requires that employers ensure that a competent person is qualified to train workers in each of the items and topics specified in § 1926.503(a)(2)(i)–(viii). Despite the difference in language between final §§ 1910.30(a)(2) and 1926.503(a)(2), OSHA believes the standards are consistent. OSHA believes that competent persons⁷⁴ “qualified” to train workers in all of the subjects and topics in the § 1926.503, or final § 1910.30, must have the capabilities of qualified persons. Accordingly, they must have capabilities (*i.e.*, extensive knowledge and demonstrated ability to solve or resolve issues) beyond those capabilities specified for competent persons (*i.e.*, to identify hazards and take corrective measures).

⁷⁴ A “competent person,” is defined by the construction rule (§ 1926.32(f)), as one who is capable of identifying existing and predictable hazards in the surroundings or working conditions that are unsanitary, hazardous, or dangerous to employees, and who has authorization to take prompt corrective measures to eliminate them.

For purposes of the final rule, a trainer must have, at a minimum, a “degree” that addresses, or “extensive knowledge” of: The types of fall hazards, how to recognize them, and the procedures to minimize them; the correct procedures for installing, inspecting, operating, maintaining, and disassembling personal fall protection systems; and the correct use of personal fall protection systems and other equipment specified in § 1910.30(a)(1). Because of the breadth of knowledge and demonstrated ability trainers in the final rule must have, OSHA believes that specifying that qualified persons must train workers best describes the capabilities necessary for training workers in the subjects § 1910.30(a) requires.

OSHA received several comments about the “qualified” person requirement in proposed paragraph (a)(2). Some commenters supported the proposed requirement. For instance, Mark Reinhart, owner of Award Window Cleaning Services (AWCS), said, “[T]raining must be by a person or persons that are experienced in the correct training procedures and competent in each area of training” (Ex. 216). He told of a company where he worked that used a veteran window cleaner to train a worker who, in turn, trained another worker:

The problem was they were all trained to be risk takers—no safety lines, no three points of contact on ladders, no safety for the public, nothing at all about fall protection. So my employer put me at risk without knowing or researching the industry to find best practices or rules governing the window cleaning industry (Ex. 216).

Mr. Andrew Horton, safety training coordinator with Service Employees International Union (SEIU) Local 32BJ, recommended OSHA require that only approved outreach trainers conduct training (Ex. 329 (1/19/2011, p. 26)).

On the other hand, some commenters opposed the “qualified” person requirement in proposed (a)(2). One commenter said the requirement was “too stringent and restrictive” (Ex. 329 (1/20/2011, p. 298)). Mr. Lankford said that requiring qualified persons to train workers meant that trainers would have to be “a specialist in fall protection, such as a vendor, manufacturer or consultant-trainer” and not a “crew chief, foreman, operations person or similar positions, even if knowledgeable” (Ex. 368). Based on his interpretation of proposed paragraph (a)(2), Mr. Lankford concluded, “There is no convincing argument that the training would not be equally effective if provided by a competent person” (Ex. 368).

OSHA believes Mr. Lankford’s interpretation of proposed paragraph (a)(2) is not accurate. The definition of “qualified” in the final rule (§ 1910.21(b)) allows employers to have crew chiefs, supervisors, operations personnel, or other individuals train workers, provided they have the necessary “degree” or “extensive knowledge” outlined in the definition of qualified, and specified in final § 1910.30(a). Final § 1910.30(a)(2) does not require that trainers possess a degree if they have the necessary knowledge, training, and experience. In fact, OSHA believes that many employers will draw upon the extensive knowledge and experience of their staffs to provide effective training. OSHA also notes that final § 1910.30(a)(2) does not require that employers use qualified persons who are employees. Employers are free to use outside personnel to train workers.

Mr. Lankford and EEI also raised concerns that requiring a qualified person to train workers would prohibit employers from using different training formats and technologies (Exs. 207; 368). Mr. Lankford said, “The [qualified person] requirement seems to exclude the use of audio-visual or computer-based-training for the purpose of complying with this requirement” (Ex. 368). Addressing the same issue, EEI said:

The OSHA regulation should allow employers to use technology to deliver training. Stand up training by a qualified person is not the only effective method of training. The OSHA regulation should allow employers to use computer based training, web based training, and video training to meet fall protection training requirements (Ex. 207).

Final paragraph (a)(2) does not require or prohibit a specific format for delivering training to workers. OSHA supports the use of different formats (*e.g.*, classroom, audio-visual, demonstration, practical exercises, field training, written) and new technology (*e.g.*, online, interactive computer-based, web-based) to train workers in accordance with § 1910.30. Thus, final paragraph (a)(2) allows employers to use video-based training and computer-based training, provided that:

- A qualified person, as defined in § 1910.21(b), developed or prepared the training;
- The training content complies with the requirements in final § 1910.30; and
- The employer provides the training in a manner each worker understands (§ 1910.30(d)).

OSHA discusses this issue in further detail in the explanation of final paragraph (d) below.

OSHA notes that employers may provide training using a format that is web based or interactive computer-based. In such cases, a qualified person must be available to answer any questions workers may have to comply with final paragraph § 1910.30(a)(2).

Final paragraph (a)(3) specifies the minimum subjects and topics that fall hazard training must cover. Final paragraph (a)(3) requires that employers provide training in at least the following topics:

- The nature of fall hazards in the work area and how to recognize them (final paragraph (a)(3)(i));
- The procedures that must be followed to minimize the hazards (final paragraph (a)(3)(ii));
- The correct procedures for installing, inspecting, operating, maintaining, and disassembling the personal fall protection systems that the worker uses (final paragraph (a)(3)(iii)); and
- The correct use of personal fall protection systems and equipment, including, but not limited to, proper hook-up, anchoring, and tie-off techniques, and methods of equipment inspection and storage as specified by the manufacturer (final paragraph (a)(3)(iv)).

OSHA drew most of the requirements in final paragraph (a)(3) from the construction fall protection standard (§ 1926.503(a)(1) and (2)). However, OSHA revised final paragraph (a)(3) in several ways. First, as discussed above under final paragraph (a)(1), OSHA added to final paragraph (a)(3) the requirements to train workers in hazard recognition and the procedures to minimize fall hazards, which were in proposed paragraph (a)(1).

Second, OSHA revised final paragraph (a)(3)(iv), proposed paragraph (a)(2)(iv), to eliminate training employees on the “limitations” of personal fall protection systems. OSHA believes it is not necessary to include that requirement in final paragraph (a)(3) because § 1910.132(f)(1)(iv) already requires training that addresses the limitations of PPE, which includes personal fall protection systems.

Third, final paragraph (a)(3) does not include the proposed requirement that employers train workers in the use and operation of “guardrail systems, safety net systems, warning lines used in designated areas, and other protection” (proposed paragraph (a)(2)(iii)). OSHA does not believe this provision is necessary because final paragraph (b) already addresses most of these fall protection systems and measures.

Finally, OSHA changed the word “erecting” to “installing” in final

paragraph (a)(3)(ii) (proposed paragraph (a)(2)(ii)). OSHA believes this clarification more accurately expresses the intent of the proposed paragraph.

Although commenters generally supported the required worker training topics and subjects outlined in final paragraph (a)(3) (Exs. 53; 189; 216; 226), others said OSHA should increase or eliminate some of the training requirements. Mr. Horton said that window cleaners need more detailed training than what OSHA proposed (Ex. 329 (1/19/2011, p. 22)). The Society of Professional Rope Access Technicians (SPRAT) recommended that OSHA specify “at least topics for knowledge, skills, and capabilities for each level of employee,” and require specific training and certification by an industry organization for rope access (Ex. 205). OSHA did not incorporate SPRAT’s recommendations in the final rule. The Agency believes that the performance-based language in the final rule provides flexibility for employers, and does not prohibit employers from providing more specialized training or requiring certification or demonstration of the employee’s knowledge, skills, and capabilities.

Ameren Corporation opposed requiring training to install and disassemble personal fall protection systems. Ameren said such training was not always necessary because some employees may not perform these tasks (Ex. 189). OSHA agrees that employers need not train employees in tasks that they do not perform. However, under the final rule, if a worker has to install and disassemble personal fall protection systems, the employer must ensure the worker knows how to perform those tasks safely and correctly before beginning the work.

Paragraph (b)—Equipment Hazards

Final paragraph (b), like the proposed rule, contains training requirements related to equipment hazards. The provisions require that employers ensure workers are trained in the following:

- The proper care, inspection, storage, and use of equipment covered by subpart D (final paragraph (b)(1));
- How to properly place and secure dockboards to prevent unintentional movement (final paragraph (b)(2));
- How to properly rig and use a rope descent system (RDS) (final paragraph (b)(3)); and
- How to properly set up and use designated areas (final paragraph (b)(4)).

Final paragraph (b)(1) applies to the extent that workers use equipment covered by subpart D. Under this provision employers must train workers

in equipment as well as fall protection systems that final paragraph (a) does not cover. Therefore, as mentioned above, training in final paragraph (b)(1) must cover equipment such as safety net systems, ladder safety systems, warning lines, portable guardrails, and motorized materials handling equipment used on dockboards.

EI said that OSHA should not require training in portable guardrails because “the purpose and use of these devices is obvious” (Ex. 207). While some workers may know how to set up and use portable guardrails, the same is not true for all workers, particularly new workers. Thus, final paragraph (b)(1) must cover portable guardrails to protect all workers from falls.

OSHA added language to final paragraph (b)(1) to clarify the date by which employers must train workers in equipment hazards. Accordingly, employers must train their current workers after OSHA publishes the final rule, and train newly hired workers before initially assigning them to a job where they may be exposed to a fall hazard. To give employers adequate time in which to develop and provide initial training, OSHA is allowing employers six months, until May 17, 2017, to provide the required training.

Like final paragraph (a), employers whose workers have received training, either from the employer or another employer, that meets the requirements of final § 1910.30(b) will not need to provide additional initial training to those workers. However, the training requirements in final § 1910.30 are new, and if the initial training workers already have received does not meet all of the requirements in the final rule, employers will need to provide initial training on those requirements.

Final paragraph (b)(2) requires employers to train workers who use dockboards on how to properly place and secure them to prevent unintentional movement. The Agency believes training in the proper positioning of dockboards (*e.g.*, adequate overlap, secure position) to avoid unintentional movement is needed to help prevent worker injury. OSHA did not make any substantive changes to proposed paragraph (b)(2) and did not receive any comments. OSHA has adopted paragraph (b)(2) with only minor revisions for clarity.

Final paragraph (b)(3) requires employers to train workers who use RDS in the proper rigging and use of the equipment, in accordance with § 1910.27. The final rule eliminates the retraining requirement specified for RDS in proposed paragraph (b)(3) because final paragraph (c) of final § 1910.30

already requires retraining. A number of commenters supported OSHA's RDS training requirements, particularly in the window cleaning industry (Exs. 65; 66; 76; 137; 222; 362; 364). Gerard McEneaney, business representative of the Window Cleaners Division of SEIU Local 32BJ, also supported the RDS training requirements, stating, "RDS relies heavily on training, workplace practices, and administrative controls to overcome its inherent dangers" (Ex. 329 (1/19/11, p. 17)). OSHA notes that workers using RDS are exposed to fall hazards and must use personal fall arrest systems; therefore, employers must train them as required by final § 1910.30(a).

Paragraph (b)(4) is a new paragraph that OSHA added to the final rule requiring employers to train each worker who uses a designated area in the proper set up and use of the area. OSHA inadvertently left this training requirement out of the proposed rule. But OSHA intended to include this requirement in the proposed rule, and the preamble noted that "it is essential for authorized employees in designated areas" to be trained (75 FR 28889). Under the final rule in some situations OSHA permits employers to protect workers from "unprotected sides and edges" on low-slope roofs by using designated areas, which final § 1910.21(b) defines as "a distinct portion of a walking-working surface delineated by a warning line in which work may be performed without additional fall protection."

Designated areas are not conventional fall protection systems or engineering controls. Designated areas are alternative fall protection methods that are effective only when set up and used correctly and safely. This alternative method relies heavily on employers properly delineating the designated area and successfully keeping workers within that area. To ensure workers follow the requirements for designated areas, OSHA believes it is important that employers train them so they know when they can use designated areas and how to set up designated areas and work in them safely.

Paragraph (c)—Retraining

Final paragraph (c), like the proposal, requires that employers retrain workers when they have reason to believe that those workers do not have the understanding and skill that final paragraphs (a) and (b) require. In particular, final paragraph (c) requires that employers retrain workers in situations including, but not limited to, the following:

- When workplace changes render previous training obsolete or inadequate (final paragraph (c)(1));
- When changes in the types of fall protection systems or equipment workers use renders previous training obsolete or inadequate (final paragraph (c)(2)); or
- When inadequacies in a worker's knowledge or use of fall protection systems or equipment indicate that the worker does not have the requisite understanding or skill necessary to use the equipment or perform the job safely (final paragraph (c)(3)).

The training requirements in this section impose an ongoing responsibility on employers to maintain worker proficiency. As such, when workers are no longer proficient, the employer must retrain them in the requirements of final paragraphs (a) and (b) before workers perform the job again. Examples of when retraining is necessary include:

- When the worker performs the job or uses equipment in an unsafe manner;
- When the worker or employer receives an evaluation or information that the worker is not performing the job safely; or
- When the worker is involved in an incident or near-miss.

Several commenters supported the proposed retraining requirements. For example, Andrew Horton, representing the SEIU Local 32BJ Window Cleaning Apprentice Training Program, said retraining is "imperative whenever there are changes in the working conditions, or there is an indication that prior training has not been effective" (Ex. 329 (1/19/2011, p. 24)).

OSHA received only one comment opposing retraining. Mr. Steve Smith of Verallia said the proposed retraining requirement was "too subjective and vague to allow for consistent application and/or enforcement." He recommended that OSHA require "training upon initial employment and annually thereafter," which OSHA's portable fire extinguisher standard requires (§ 1910.157) (Ex. 171).

OSHA disagrees that the performance-based language in proposed paragraph (c) is too vague and subjective. OSHA believes that final paragraph (c) specifies clearly when retraining is necessary. The language in final paragraph (c) is similar to the retraining provisions in other OSHA standards, including the PPE (§ 1910.132(f)(3)), lockout/tagout (§ 1910.147(c)(7)(iii)), and powered industrial truck standards (§ 1910.178(l)(4)). Those standards have been effective in ensuring that workers receive additional training when necessary. OSHA also believes that the

performance-based retraining requirements in final paragraph (c) provide greater flexibility for employers than requiring annual retraining.

OSHA also disagrees with Mr. Smith's recommendation that OSHA limit the final rule to "training upon initial employment and annually thereafter." This language appears to require that employers must train new workers, but would not have to train current employees after OSHA publishes the final rule. As discussed above, OSHA believes that employers need to provide retraining to current workers in accordance with final § 1910.30 when previous training is obsolete or inadequate. Finally, OSHA believes that identifying the specific situations when employers must provide retraining more precisely targets the real need for additional training than does an inflexible requirement such as annual training. Therefore, OSHA believes the final rule will be more effective, and will provide employers with more flexibility, than the alternative Mr. Smith recommends.

Paragraph (d)—Training Must Be Understandable

Final paragraph (d), like the proposed rule, requires that employers provide information and training to each worker in a manner that the employee understands. This language indicates that employers must provide information and instruction in a manner that workers receiving the training are capable of understanding so they will be able to perform the job in a safe and proper manner.

The final rule makes clear that training must account for the specific needs and learning requirements of each worker. For example, if a worker does not speak or adequately comprehend English, the employer must provide training in a language that the worker understands. Also, if a worker cannot read, employers will need to use a format, such as audio-visual, classroom instruction, or a hands-on approach, to ensure the worker understands the training they receive. Similarly, if a worker has a limited vocabulary, the employer must provide training using vocabulary the worker comprehends.

An increasing number of employers are using computer-based and web-based training (Exs. 207; 329 (1/20/2011, p. 191); 368). In such situations, final paragraph (d) requires that employers ensure that workers have adequate computer skills so they can operate the program and understand the information presented. Moreover, to ensure that employees "understand" computer-based training, as well as

other types of training, OSHA believes it may be necessary for employers to ensure that a qualified person is available to answer questions and clarify information. For example, when employers use computer-based training, they could make a qualified person “available” through an interactive computer program (e.g., WebEx), or have a qualified person present to answer questions. (For additional information on making training understandable, see OSHA’s Training Standards Policy Statement).⁷⁵

OSHA believes that employers should not have difficulty complying with final paragraph (d), or any other provision in § 1910.30. Many industry, labor, and professional organizations; training consultants; vendors; and manufacturers already provide employers with training and training materials to ensure that workers understand how to perform the job and use equipment correctly and safely (Exs. 329 (1/18/2011, pgs. 82, 117, 186, 258); 329 (1/20/2011, pgs. 182, 287); 329 (1/21/2011, pgs. 9, 92, 200, 206)).

A number of commenters said they already provide bi-lingual or multi-lingual training (Exs. 329 (1/19/2011, pgs. 118, 241, 319, 352, 413, 416, 462)). In addition, training and professional organizations have bi-lingual training materials available. For instance, the International Window Cleaning Association Safety Certification Program provides a bi-lingual study curriculum (Ex. 222).

Many commenters said they already use different formats (e.g., classroom, audiovisual, demonstration, practical exercises, field training, written) and new technology (e.g., interactive computer-based, web-based) to ensure that training is understandable (Ex. 329 (1/18/2011, pgs. 148, 258)). Commenters also said they use testing and training evaluation to ensure employees understand training (Ex. 329 (1/20/2011, p. 318)). Some commenters also supported certification of employee training by independent groups (e.g., professional organizations) (Exs. 205; 222; 364).

Some commenters said they are using “interactive training” to make training understandable. For instance, SEIU Local 32BJ said their window cleaner training programs are “highly interactive” (Ex. 329 (1/19/2011, pgs. 120–121)), and they support requiring “interactive” training. Diane Brown, senior health and safety specialist with

AFSCME, agreed, stating, “Training should be as interactive as possible. We support . . . [adopting] training methods that ensure workers get the information they need” (Ex. 226). Eric Frumin, health and safety director with Change to Win, stated:

[I]t’s not sufficient for OSHA to simply require employers to provide training in a language that workers understand. . . . It’s one of the most important advances in OSHA rulemaking, to assure that the training is not only done in a language the workers understand, but that it’s interactive, that workers have a chance to ask questions (Ex. 329 (1/19/2011, p. 119)).

Some commenters said OSHA should require that employers use specific training methods and techniques. For example, SEIU said training should include “some combination of hands-on and classroom training methods that have been so successful in our training” (Ex. 329 (1/19/2011, pgs. 25–26)). Ellis Fall Safety Solutions said that training methods must include the following:

[T]here has to be a written curriculum, a presentation and written or recorded tests [that] see if the material has been picked up and the final thing is to check by observing discretely if the work is being done to the proper methodology that was taught. All these are subject to verification by a CSHO (Ex. 155).

Some commenters said that supervision is necessary to ensure training is successful. For instance, Mr. Frumin said, “You can’t take the chance that someone didn’t understand the training. You’ve got to supervise them,” (Exs. 329 (1/19/2011, pgs. 122–23); 329 (1/21/2011, p. 21)).

OSHA agrees that many of the training methods and elements the commenters recommend can help to make workplace training understandable, and generally supports their use. The Agency also believes that the final rule should give employers flexibility to develop training programs and use those training methods that best fit the needs of their workers and workplace. Therefore, OSHA finalizes paragraph (d) with only minor revisions for clarity.

OSHA also received comment on other training issues, including whether the final rule should require a minimum amount of time for worker training. Mr. Horton of SEIU Local 32BJ urged that OSHA mandate that training be a “minimum number of hours to prevent any inadvertent or negligent training failures” (Ex. 329 (1/19/2011, p. 25)). In contrast, Mr. Robert Miller, senior safety supervisor with Ameren Corporation, said OSHA should not set time requirements for providing training because it would interfere with the

performance-based approach in the proposed rule (Ex. 189). Proposed § 1910.30 did not require that training meet a minimum time requirement, and there is no minimum time requirement for training in final § 1910.30. OSHA notes that the preliminary and final economic analysis include times for training, but the Agency notes that it included those times only for the purpose of the estimating the costs of the final rule.

Finally, ASSE suggested that § 1910.30 include a specific reference to the ANSI/ASSE Z490.1 consensus standard (Criteria for Accepted Practices in Safety, Health and Environmental Training) as a source of guidance information for employers (Ex. 127). That voluntary standard establishes criteria for safety, health, and environmental training programs. OSHA agrees that the consensus standard may be a valuable source of information about training programs. However, it does not address walking-working surfaces or fall and equipment hazards and OSHA has decided to not reference the standard in the final rule.

B. Final § 1910.140

OSHA is adding a new section to subpart I Personal Protective Equipment (PPE) (29 CFR 1910, subpart I) to address personal fall protection systems, which include personal fall arrest, travel restraint, and positioning systems (29 CFR 1910.140). The new section establishes requirements for the design, performance, use, and inspection of personal fall protection systems and system components (e.g., body harnesses, lifelines, lanyards, anchorages).

OSHA also is adding two non-mandatory appendices that provide information to help employers select, test, use, maintain, and inspect personal fall protection equipment (Appendix C) and examples of test methods for personal fall arrest and positioning systems to ensure that they meet the requirements of § 1910.140 (appendix D).

In the final rule, OSHA adapts many provisions from its other fall protection standards, primarily Powered Platforms for Building Maintenance (29 CFR 1910.66, appendix C); Personal Fall Arrest Systems in Shipyard Employment (29 CFR 1915.159); Positioning Device Systems in Shipyard Employment (29 CFR 1915.160); and Fall Protection in Construction (29 CFR part 1926, subpart M). These adaptations ensure that OSHA fall protection rules are consistent across various industries. OSHA notes that other standards also require the use of

⁷⁵ OSHA’s Training Standards Policy Statement is available from OSHA’s website at: <https://www.osha.gov/dep/standards-policy-statement-memo-04-28-10.html>.

personal fall protection systems (Vehicle-Mounted Elevating and Rotating Work Platforms (Aerial Lifts) (29 CFR 1910.67(c)(2)(v)); Telecommunications (29 CFR 1910.268(g)); and Electric Power Generation, Transmission, and Distribution (29 CFR 1910.269(g)); however, the requirements and criteria in those standards generally are not comprehensive or broadly applicable.

Similar to the final rule revising 29 CFR part 1910, subpart D, final § 1910.140, when appropriate, also draws from national consensus standards addressing personal fall protection systems. Those standards include:

- ANSI/ALI A14.3–2008, American National Standards for Ladders—Fixed (A14.3–2008) (Ex. 8);
- ANSI/ASSE A10.32–2012, Personal Fall Protection Used in Construction and Demolition Operations (A10.32–2012) (Ex. 390);
- ANSI/ASSE Z359.0–2012, Definitions and Nomenclature Used for Fall Protection and Fall Arrest (Z359.0–2012) (Ex. 389);
- ANSI/ASSE Z359.1–2007, Safety Requirements for Personal Fall Arrest Systems, Subsystems, and Components (Z359.1–2007) (Ex. 37);
- ANSI/ASSE Z359.3–2007, Safety Requirements for Positioning and Travel Restraint Systems (Z359.3–2007) (Ex. 34);
- ANSI/ASSE Z359.4–2013, Safety Requirements for Assisted-Rescue and Self-Rescue Systems (Z359.4–2013) (Ex. 22);
- ANSI/ASSE Z359.12–2009, Connecting Components for Personal Fall Arrest System (Z359.12–2009) (Ex. 375); and
- ANSI/IWCA I–14.1–2001, Window Cleaning Safety (I–14.1–2001) (Ex. 10).

The final rule adopts a number of the provisions in proposed § 1910.140 with only minor, non-substantive technical or editorial changes. For many of these provisions, OSHA did not receive any comments from the public. Other provisions in the final rule include revisions based on information in the record and comments OSHA received. OSHA also revised provisions in the proposed rule to clarify the final rule, thereby making it easier for employers, workers, and others to understand.

Section 1910.140—Personal Fall Protection Systems

Paragraph (a)—Scope and Application

Paragraph (a) of the final rule specifies that employers must ensure each personal fall protection system that part 1910 requires complies with the

performance, care, and use criteria specified in § 1910.140. This section defines “personal fall protection system” as a system that workers use to provide protection from falling, or safely arrest a fall if one occurs (§ 1910.140(b)). As mentioned earlier, personal fall protection systems include personal fall arrest, travel restraint, and positioning systems.

OSHA notes that not only does § 1910.140 apply to the new and revised requirements in subpart D, but also it applies to existing requirements in part 1910 that mandate or allow employers to protect workers from fall hazards using personal fall protection systems (§§ 1910.66; 1910.67; 1910.268; and 1910.269).

OSHA believes that the scope of final § 1910.140 and the requirements the final rule establishes are necessary. Importantly, OSHA did not receive any comments opposing the scope and application in paragraph (a). OSHA believes that without establishing design and performance criteria, there is risk that personal fall protection systems, particularly personal fall arrest systems, may fail and put workers at risk of harm. Such failure can occur for a number of reasons, including using:

- The wrong or inadequate system (especially one that is not strong enough for the particular application in which it is being used);
- A system not tested or inspected before use;
- A system not rigged properly;
- A system that does not have compatible components; or
- A system on which workers are not properly trained.

For several reasons, OSHA believes that employers should not experience significant difficulty complying with the final rule. Most of the requirements in the final rule come from OSHA’s existing fall protection standards, as well as national consensus standards addressing fall protection, which also have been in place for years and represent industry best practices. Accordingly, OSHA believes that virtually all personal fall protection systems manufactured today meet the requirements in those standards as well as final § 1910.140. In addition, to assist employers in complying with the rule, OSHA includes an appendix in the final rule to provide employers with readily accessible information that will help them comply with final § 1910.140.

Paragraph (b)—Definitions

Final paragraph (b) defines terms that are applicable to final § 1910.140. OSHA believes that defining key terms will

make the final rule easier to understand and, thereby, will increase compliance.

OSHA drew most of the definitions in paragraph (b) from existing OSHA and national consensus standards on fall protection. For instance, many of the terms in this paragraph also are found in the Powered Platforms standard (§ 1910.66(d) and appendix C); construction standards (§§ 1926.450(b), 1926.500(b) and 1926.1050(b)), and the shipyard employment PPE standard (§ 1915.151). OSHA believes that having consistent definitions across the Agency’s standards will increase understanding of OSHA’s fall protection rules, decrease the potential for confusion, and enhance worker safety. Having consistent definitions also will help to increase understanding and compliance for workers engaged in more than one type of work, such as general industry and construction activities.

Final paragraph (b) differs from the proposed rule in several respects. First, the final rule does not retain the proposed definitions for the following terms because OSHA does not use these terms in final § 1910.140: “buckle” and “carrier.” Second, final paragraph (b) adds two new terms to the proposed definitions: “carabiner” and “safety factor.” Third, the final rule also substantially modifies the definition of “competent person” from the proposed rule. OSHA believes that additional revisions, particularly those made in response to commenter suggestions, clarify the meaning of the terms, and ensure that they reflect current industry practice.

OSHA carries forward the following terms and definitions from the proposed rule without change, or with mostly minor editorial and technical changes. In revising final paragraph (b), OSHA used plain and performance-based language. The Agency believes these types of revisions make the terms and definitions easy for employers and workers to understand. OSHA believes many of the remaining definitions are “terms of art” universally recognized by those who use personal fall protection systems. Even so, OSHA still received comments on a number of the definitions, as discussed below.

Anchorage. The final rule, like the proposal, defines “anchorage” as a secure point of attachment for equipment such as lifelines, lanyards, or deceleration devices. The definition in the final rule is consistent with the one in OSHA’s Powered Platforms, construction, and shipyard employment fall protection standards (§§ 1910.66, appendix C, Section I(b); 1915.151(b); 1926.500(b)) as well as the definition in

A10.32–2012 (Section 2.4) and Z359.0 (Section 2.5).

OSHA notes that the anchorage definition in the Powered Platforms standard requires that the anchorage must be “independent of the means of supporting or suspending the employee.” The final rule also includes this requirement in § 1910.140(c)(12), discussed below. OSHA did not receive any comments on the proposed definition.

Belt terminal. As defined in the final rule, this term means an end attachment of a window cleaner’s positioning system used to secure the body harness or belt to the window cleaner’s belt anchor. The term is specific to fall protection for window cleaning operations.

Neither existing OSHA fall protection standards nor I–14.1–2001 define the term. Although OSHA believes the meaning of “belt terminal” is clear, the Agency is including the definition in the final rule to clarify the system or criteria of requirements for window cleaner’s positioning systems (see discussion of § 1910.140(e)). OSHA did not receive any comments or opposition to including the definition, and adopts the definition as proposed.

Body belt. The final rule defines “body belt” as a strap with means both for securing it about the waist and for attaching it to other components such as a lanyard used with positioning, travel restraint, or ladder safety systems. The definition of “body belt” in final rule generally is consistent with OSHA’s Powered Platforms, construction, and shipyard employment fall protection standards (§§ 1910.66, appendix C, Section I(b); 1915.151(b); 1926.500(b)). However, those definitions do not specify with which systems employers may use body belts. The final rule clarifies that employers may use body belts only with positioning, travel restraint, and ladder safety systems, and the final rule adds language specifying that employers cannot use body belts with personal fall arrest systems (see discussion in § 1910.140(d)(3)). Including this language makes the final definition consistent with the definition in A10.32. That standard defines “body belt,” which it also refers to as a safety or waist belt, as “support which is used for positioning, restraint or ladder climbing only” (A10.32–2012, Section 2.8).

The Z359.0 standard uses the term “body support” instead of body belt, and defines it as “an assembly of webbing arranged to support the human body for fall protection purposes, including during and after fall arrest” (Section 2.17). A note to the definition

explains that body support generally refers to a harness (full body, chest, chest-waist) or body belt. OSHA did not receive any comments on the definition and adopts the definition as proposed.

Body harness. The final rule defines “body harness” as straps that secure about a worker in a manner that distributes fall arrest forces over at least the worker’s thighs, pelvis, waist, chest, and shoulders should a fall occur. The final rule specifies that a body harness also is a means for attaching it to other components of a personal fall protection system.

The final rule is nearly identical to the definition of “body harness” in OSHA’s Powered Platforms, construction, and shipyard employment fall protection standards (§§ 1910.66, appendix C, Section I(b); 1915.151(b); 1926.500(b)), as well as the definition of “body support” in A10.32 (Section 2.9). The Z359.0 standard includes definitions of various types of body harnesses, including chest harnesses, chest-waist harnesses, evacuation harnesses, full-body harnesses, and positioning harnesses. The definition in the final rule is consistent with the “full body harness” definition in Z359.0 (Section 2.83).

In the proposal, OSHA requested comment on whether the Agency should define other types of harnesses in the final rule, specifically those harnesses that do not have a waist strap or component (75 FR 28903). ISEA (Ex. 185) and CSG (Ex. 198) both said that ISEA-member companies reported that it was more common for body harnesses not to have waist straps. They said this type of harness distributes fall arrest forces over the entire torso and has assemblies that prevent the shoulder straps from separating to the extent that the worker could fall out of the harness. OSHA concludes that this type of harness meets the definition of “body harness,” and it is not necessary to revise the term. However, in the final rule, OSHA did not include the other specific types of body harnesses (e.g., chest-waist, chest) listed in Z359.0. The other types of harnesses do not spread fall arrest forces across a broad area of the body, and the final rule does not permit their use.

With one exception, the definition in the final rule also is consistent with I–14.1–2001. The definition of “body harness” in I–14.1–2001 permits the distribution of fall arrest forces over “any combination” of the thighs, pelvis, waist, chest, and shoulders, rather than across all of those parts of the worker’s body combined (Section 2). The final rule, by contrast, does not incorporate the “any combination” language in I–

14.1. OSHA believes that adopting the language from I–14.1–2001 would allow employers to use harnesses that concentrate fall arrest forces in a small anatomical area, rather than across the entire torso and thighs. The dangers of concentrating fall arrest forces in a limited anatomical area (e.g., waist and chest only) are well documented. In the proposed rule, OSHA discussed research of Dr. Maurice Amphoux, *et al.* conducted on the use of thoracic harnesses for personal fall arrest. Their study concluded that such harnesses are not suitable for personal fall arrest because the forces transmitted to the body during post-fall suspension constricted the rib cage and could cause asphyxiation (75 FR 28903). The proposed rule also identified an increased danger of falling out of chest-waist harnesses. Therefore, OSHA believes that the definition of “body harness” in the final rule is more protective than the one in I–14.1–2001.

Carabiner. The final rule defines carabiner as a connector comprised generally of a trapezoidal or oval-shaped body with a closed gate or similar arrangement that may be opened to attach another object. When released, the carabiner gate automatically closes to retain the object. There are generally three types of carabiners:

- Automatic locking, with a self-closing and self-locking gate that remains closed and locked until intentionally unlocked and opened for connection or disconnection;
- Manual locking, with a self-closing gate that must be manually locked by the user and that remains closed and locked until intentionally unlocked and opened by the user for connection or disconnection; and
- Non-locking, with a self-closing gate cannot be locked.

Commenters recommended that OSHA apply to carabiners the same criteria applicable to snaphooks (Exs. 185; 198). For example, the International Safety Equipment Association (ISEA) said that applying the snaphook performance criteria to carabiners would ensure that the final rule specifically covers the two most common types of connectors (Ex. 185). OSHA agrees, and added a definition of carabiner to the final rule that is almost identical to the one in Z359.0–2012 (Section 2.20) and A10.32–2012 (Section 2.12). Those definitions note that there are three types of carabiners: Automatic locking (*i.e.*, self-closing and self-locking), manual locking, and non-locking. The final rule, like Z359.0 and A10.32, only allows the use of automatic-locking carabiners and snaphooks.

Competent person. In the final rule, OSHA defines a “competent person” as a person who:

- Is capable of identifying existing and predictable hazards in any personal fall protection system or component as well as in their application and uses with related equipment; and
- Has the authorization to take prompt corrective measures to eliminate the identified hazards.

The definition in the final rule differs from the proposed definition in two ways. First, the final rule requires that the competent person be capable of identifying both “existing and predictable hazards,” while the proposal specified that the competent person identify existing “hazardous or dangerous conditions.” Second, the final rule adds language specifying that competent persons must have authority to take prompt, corrective actions to eliminate the hazards that they identified. These changes expand the definition of competent person and make the final rule consistent with the definition applicable to OSHA’s construction standards (§ 1926.32), as well as the definition in Z359.0–2012 (Section 2.30) and A10.32–2012 (Section 2.16).

Under the final rule employers must ensure that the worker(s) they select to be the competent person(s) have the capability and competence to identify existing hazards and predictable hazards (*i.e.*, hazards likely to occur when using personal fall protection systems, components, and related equipment). Competent persons working with personal fall protection systems in construction already must be able to identify both existing and predictable hazards. OSHA believes that requiring the same of competent persons in general industry establishments that also perform construction activities should not pose a problem, especially since they may be the same person.

OSHA added the language requiring that competent persons have authority to take prompt corrective action in response to the large number of commenters who urged OSHA to adopt that language from OSHA’s construction standards (§ 1926.32), Z359.0, and A10.32. OSHA did not include the language in the proposed rule because the Agency believed that competent persons dealing with personal fall protection systems in general industry were likely to serve a different function than competent persons in the construction industry (75 FR 28904). In the preamble to the proposed rule, OSHA said that the competent person in general industry most likely would be an outside contractor who specializes in

fall protection systems, designs fall protection systems, and/or provides fall protection training. OSHA said it would be unlikely that employers would grant an outside contractor authority over work operations. In addition, OSHA said it did not believe the definition of competent person in § 1926.32 was widely recognized and accepted in general industry. Thus, in the proposed rule OSHA used the definition of competent person from appendix C of § 1910.66.

By contrast, when OSHA promulgated the construction fall protection standards, the Agency applied the definition of “competent person” in § 1926.32 because the Agency found that the construction industry widely recognized the term, which OSHA adopted in 1971 pursuant to Section 6(a) of the OSH Act (29 U.S.C. 655(a)). However, commenters on the proposed rule said that the construction industry definition is as widely known, accepted, and used in general industry as it is in the construction industry (Exs. 74; 122). They urged OSHA to incorporate the construction industry definition of competent person in § 1910.140.

Many commenters who disagreed with the proposed definition said that it is essential that the competent person have authority to take prompt corrective action when they find hazards (Exs. 69; 74; 185; 190; 198; 226). They argued that the duty of the competent person is to ensure that personal fall protection systems, components, and related equipment are safe, and they cannot carry out that duty without having the ability to take corrective action to keep the system working properly and the workplace safe. In addition, they said that employers, workers, fall protection equipment suppliers, and national consensus standards all operate with the expectation that a competent person will have authority to take action when needed to correct problems. The American Foundry Society, for instance, pointed out:

Without any such authority, a competent person under this definition will be put in the position of being able to recognize the hazard, but likely not be able [to] do anything about it. That is not a truly competent person and does not reflect the needed level of competence to help ensure worker safety (Ex. 190).

Similarly, ISEA said that OSHA’s proposed definition amounted to a subject matter expert rather than a competent person. They asserted that the rule must define a competent person as one who is on site; has authority to shut down work operations if there are imminent hazards; and take PPE, including personal fall protection

systems, out of service if needed (Ex. 185).

The American Federation of State, County and Municipal Employees (AFSCME) (Ex. 226) also supported giving the competent person authority to take prompt, corrective action. AFSCME said that many employers may seek outside assistance in assessing the risks and types of fall protection systems, but that no outside party should be an employer’s competent person:

It is more likely that an internal supervisor would be given the responsibility for ensuring the employer’s fall protection systems are in place, equipment is inspected, and that employees are trained and using equipment properly. This person or persons should be competent in the meaning of the standard, and should have the authority to correct hazards when found (Ex. 226).

ISEA made a similar point, saying that it was in the best interest of worker protection to have an on-site accountable decision maker because the competent person would be able to examine the personal fall protection systems, components, and related equipment and know firsthand the risks involved. Armed with that knowledge, ISEA said an on-site competent person would be less likely to take risks with workers’ lives. ISEA said that manufacturers and other knowledgeable sources who are not on-site will not have the knowledge to make service-life decisions about fall arrest equipment. Capital Safety Group (CSG) (Ex. 198) agreed, saying that on-site, accountable decision makers who are fully aware of the risks associated with fall protection equipment are less likely to put workers’ lives in jeopardy. Access Rescue (Ex. 69) and Extreme Access, Inc. (Ex. 74), expressed similar concerns.

OSHA agrees with commenters that, to ensure workers have safe personal fall protection systems, components, and related equipment the competent person must have authority to take necessary corrective action when they identify hazards. In addition, adding the language to the final rule will make the definition consistent with the widely known term in OSHA’s construction standard and national consensus standards, which should increase employer compliance.

OSHA also agrees with commenters that, to carry out their role, competent persons should be on-site. With appropriate training and experience, OSHA believes that a worker at the worksite can function as the competent person.

Connector. The final rule, like the proposal, defines “connector” as a

device used to couple or connect together parts of a personal fall protection system. Examples of connectors include snaphooks, carabiners, buckles, and D-rings.

The definition in the final rule is derived from OSHA's Powered Platforms, construction, and shipyard employment fall protection standards, as well as Z359.0–2012 (Section 2.36) and A10.32–2012 (Section 2.18). The definition of “connector” in those standards includes information explaining that connectors may be independent components of a personal fall protection system or integral parts sewn into the system. Since the final rule permits employers to use connectors that are either independent or integral components of a personal fall protection system, OSHA does not believe it is necessary to include the explanatory material in the final definition of “connector.” OSHA did not receive any comments and adopts the definition as proposed.

D-ring, as used in the final rule, is a connector used in:

- Harnesses, as an integral attachment element or fall arrest attachment;
 - Lanyards, energy absorbers, lifelines, or anchorage connectors as an integral connector; or
 - A positioning or travel restraint system as an attachment element.
- “Integral” means the D-ring cannot be removed (e.g., sewn into the harness) from the body harness without using a special tool. The final rule is consistent with A10.32–2012, which defines “integral” to mean “[n]ot removable from the component, subsystem or system without destroying or mutilating any element or without use of a special tool” (Section 2.30).

Although OSHA's existing fall protection standards do not define “D-ring,” the final rule is consistent with Z359.0–2012 (Section 2.41). The A10.32–2012 standard does not explicitly define “D-ring,” but the definition of “connector” includes D-ring as an example of an integral component of a body harness. The definition also says a D-ring is a connector sewn into a body harness or body belt (Section 2.18). OSHA did not receive any comments on the proposed definition and has adopted the definition with minor editorial revisions.

Deceleration device, like in the proposed rule, is defined as any mechanism that serves to dissipate energy during a fall. The final rule is similar to the definition in OSHA's Powered Platforms, construction, and shipyard employment fall protection standards (§§ 1910.66, appendix C, Section I(b); 1915.151(b); 1926.500(b)),

and almost identical to the definition in A10.32–2012 (Section 2.19). The definition in those standards also provides examples of deceleration devices that employers may use to dissipate energy during a fall, including rope grabs, rip-stitch lanyards, specially woven lanyards, tearing or deforming lanyards, and automatic self-retracting lifelines or lanyards.

Although the Z359.0 standard does not define “deceleration device,” it includes definitions for “energy (shock) absorber,” “fall arrester,” and “self-retracting lanyard” (Sections 2.46, 2.60, 2.159). In the Powered Platforms and construction fall protection rulemakings, commenters recommended replacing “deceleration device” with those terms. OSHA also received similar recommendations in this rulemaking (Exs. 121; 185; 198). For instance, ISEA (Ex.185) and CSG (Ex. 198) recommended defining “fall arrester” and “energy absorber” because they said “deceleration device” is not a commonly used term. Clear Channel Outdoor, Inc. (Ex. 121), also supported replacing “deceleration device” with the terms in Z359.0 “to increase consistency.” By contrast, Ameren said “deceleration device” was “standard verbiage” in OSHA fall protection standards, and removing the term was not necessary “[a]s long as there is no confusion with the terms” (Ex.189).

OSHA agrees with Ameren that using the term “deceleration device” makes the final rule consistent with OSHA's other fall protection standards and would eliminate, rather than generate, confusion. In the preamble to the final construction fall protection standard, OSHA explained why the Agency was not adding definitions for “fall arrester” and “energy absorber,” stating:

It was suggested that [deceleration device] be eliminated and replaced with three terms, “fall arrester,” “energy absorber,” and “self-retracting lifeline/lanyard” because the examples listed by OSHA in its proposed definition of deceleration device serve varying combinations of the function of these three suggested components. In particular, it was pointed out that a rope grab may or may not serve to dissipate a substantial amount of energy in and of itself. The distinction that the commenter was making was that some components of the system were “fall arresters” (purpose to stop a fall), others were “energy absorbers” (purpose to brake a fall more comfortably), and others were “self-retracting lifeline/lanyards” (purpose to take slack out of the lifeline or lanyard to minimize free fall). OSHA notes, however, that it is difficult to clearly separate all components into these three suggested categories since fall arrest (stopping) and energy absorption (braking) are closely related. In addition, many self-retracting lifeline/lanyards serve all three functions

very well (a condition which the commenter labels as a “subsystem” or “hybrid component”). OSHA believes that the only practical way to accomplish what is suggested would be to have test methods and criteria for each of the three component functions. However, at this time, there are no national consensus standards or other accepted criteria for any of the three which OSHA could propose to adopt.

In addition, OSHA's approach in the final standard is to address personal fall arrest equipment on a system basis. Therefore, OSHA does not have separate requirements for “fall arresters,” “energy absorbers,” and “self-retracting lifeline/lanyards” because it is the performance of the complete system, as assembled, which is regulated by the OSHA standard. OSHA's final standard does not preclude the voluntary standards writing bodies from developing design standards for all of the various components and is supportive of this undertaking (59 FR 40672 (8/9/1994) (citing 54 FR 31408, 31446 (7/28/1989))).

OSHA believes the preamble discussion in the earlier rulemakings holds true today and supports only including the definition of “deceleration device” in the final rule. Accordingly, the final rule adopts the definition of “deceleration device” specified in the proposal.

Deceleration distance. The final rule, like the proposal, defines “deceleration distance” as the vertical distance a falling worker travels before stopping, that is, the distance from the point at which the deceleration device begins to operate to the stopping point, excluding lifeline elongation and free fall distance. The final rule also states that “deceleration distance” is the distance between the location of a worker's body harness attachment point at the moment of activation of the deceleration device during a fall (i.e., at the onset of fall arrest forces), and the location of that attachment point after the worker comes to a full stop.

The definition in the final rule is almost identical to the definition in OSHA's Powered Platforms, construction, and shipyard employment fall protection standards (§§ 1910.66, appendix C, Section I(b); 1915.151(b); 1926.500(b)), but does not reference body belts because the final rule prohibits the use of body belts in personal fall arrest systems. The final rule also is consistent with A10.32–2012 (Section 2.20) and with the definition and explanatory note in Z359.0–2012 (Section 2.40). OSHA did not receive any comments on the proposed definition of “deceleration device” and adopts the proposed definition.

Equivalent. The final rule defines “equivalent” as alternative designs, equipment, materials, or methods that the employer can demonstrate will

provide an equal or greater degree of safety for workers compared to the designs, equipment, materials, or methods the final rule specifies. The definition in the final rule is essentially the same as the definition in OSHA's Powered Platforms, shipyard employment, and construction fall protection standards (§§ 1910.66(d) and appendix C, Section I(b); 1915.151(b); 1926.500(b)). A crucial element of the definition is that the employer has the burden to demonstrate that the alternative means are at least as protective as the designs, materials, or methods the standard requires.

Verallia (Ex. 171) commented that the proposed definition was "too subjective and vague to allow for consistent application and/or enforcement." Verallia also said the proposal outlined the skill set necessary to be a "qualified" person, and that it should be sufficient if a qualified person selects the alternative designs, equipment, materials, or methods. OSHA disagrees with Verallia's characterization of the proposed definition. Since 1974, OSHA used the same definition of "equivalent" in various standards (e.g., §§ 1910.21(g)(6); 1926.450(b)). Over this period, the Agency experienced no problems achieving consistent application of the definition, and employers did not report that the term is too vague. To the contrary, OSHA believes that employers support the definition of "equivalent" because it gives them flexibility in complying with the final rule, provided that they can show that their selected methods, materials, or designs provide equal or greater level of safety for workers. Accordingly, the final rule adopts the proposed definition with only minor changes for clarity.

Free fall, like in the proposed rule, is defined as the act of falling before the personal fall arrest system begins to apply force to arrest the fall. The final definition is almost the same as the definition in OSHA's Powered Platforms, construction, and shipyard employment fall protection standards (§§ 1910.66, appendix C, Section I(b); 1915.151(b); 1926.500(b)). It also is identical to the definition in Z359.0–2012 (Section 2.73), and is consistent with the definition in A10.32–2012 (Section 2.26). OSHA did not receive any comments on the proposed definition and finalizes it as proposed.

Free fall distance means the vertical displacement of the fall arrest attachment point on the worker's body harness between the onset of the fall and just before the system begins to apply force to arrest the fall. The distance excludes deceleration distance,

lifeline and lanyard elongation, but includes any deceleration device slide distance or self-retracting lifeline/lanyard extension before the devices operate and fall arrest forces occur.

The definition in the final rule is essentially the same as the definition in OSHA's Powered Platforms, construction, and shipyard employment fall protection standards (§§ 1910.66 appendix C, Section I(b); 1915.151(b); 1926.500(b)). In addition, the final rule is consistent with the definition in Z359.0–2012 (Section 2.74) and A10.32–2012 (Section 2.27). OSHA did not receive any comments on the proposed definition.

Lanyard, like in the proposed rule, is defined as a flexible line of rope, wire rope, or strap that generally has a connector at each end to connect a body harness or body belt to a deceleration device, lifeline, or anchorage. The definition in the final rule is almost identical to the Powered Platforms standard (§ 1910.66(b) and appendix C, Section I(b)), and consistent with the definition in OSHA's construction and shipyard employment fall protection standards (§§ 1915.151(b) and 1926.500(b)). The definition in the final rule also is consistent with Z359.0–2012 (Section 2.94) and A10.32–2012 (Section 2.31), although the definition in A10.32 does not include body belts. OSHA did not receive any comments on the proposed definition, and adopts the definition as proposed.

Lifeline. The final rule, like the proposal, defines "lifeline" as a component of a personal fall protection system that connects other components of the system to the anchorage. A lifeline consists of a flexible line that either connects to an anchorage at one end to hang vertically (a vertical lifeline), or connects to anchorages at both ends to stretch horizontally (a horizontal lifeline).

The final rule is consistent with the definition of lifeline in Z359.0–2012 (Section 2.96) and A10.32–2012 (Section 2.33), however, it differs slightly from OSHA's Powered Platforms, construction, and shipyard employment fall protection standards (§§ 1910.66(b) and appendix C, Section I(b); 1915.151(b); 1926.500(b)). OSHA's existing standards only apply to personal fall arrest systems, and define "lifeline" as a component of such a system. The final definition specifies that a lifeline is a component of a personal fall protection system, which includes fall arrest, positioning, and travel restraint systems. The final definition also includes some minor editorial revisions. OSHA did not receive any comments on the proposed

definition and adopts the definition as discussed.

Personal fall arrest system, like the proposed rule, is defined as a system used to arrest a worker's fall from a walking-working surface. As the final rule specifies, a personal fall arrest system consists of a body harness, anchorage, and connector. The means of connecting the body harness and anchorage may be a lanyard, deceleration device, lifeline, or suitable combination of these means. In the final rule, OSHA fully details what the components of personal fall arrest systems include, specifically, the various means of connecting body harnesses and anchorages (i.e., lanyards, deceleration devices, lifelines, or a suitable combination of these means). OSHA believes that fully clarifying the components will help employers and workers better understand the personal fall arrest system requirements in the final rule.

The definition in the final rule is consistent with OSHA's Powered Platforms, construction, and shipyard employment fall protection standards (§§ 1910.66(b) and appendix C, Section I(b); 1915.151(b); 1926.500(b)). Those OSHA standards, however, specify that a fall arrest system may consist of either a body harness or a body belt. Since the time OSHA promulgated those standards, the Agency phased out the use of body belts in personal fall arrest systems due to safety concerns. Effective January 1, 1998, OSHA banned the use of body belts as part of personal fall arrest systems in the construction and shipyard employment standards (§§ 1926.502(d); 1915.159), and this final rule also prohibits their use in personal fall arrest systems.

The final rule is consistent with Z359.0–2012 (Section 2.115) and A10.32–2012 (Section 2.38). The consensus standards, like the final rule and OSHA's existing standards, require the use of body harnesses in personal fall arrest systems, and prohibit body belts.

Personal fall protection system, as defined in the final rule, means a system (including all components) that employers use to provide protection for employees from falling or to safely arrest a fall if one occurs. The final definition identifies examples of personal fall protection systems, including personal fall arrest systems, positioning systems, and travel restraint systems. Neither existing OSHA fall protection standards nor national consensus standards define personal fall protection system.

Some commenters (Exs. 155; 185; 198) said that OSHA should not use

“personal fall protection system” because employers could interpret the term to include passive devices such as guardrails. They suggested using only the term “personal fall arrest system.” In addition, Ellis Fall Safety Solutions (Ellis) (Ex. 155) recommended that the term “personal fall protection system” only include systems that use body harnesses; in other words, limited to personal fall arrest systems.

OSHA does not believe that employers will mistake the term “personal fall protection system” to include passive fall protection devices such as guardrails and safety nets. The Z359.0–2012 standard includes two types of fall protection systems: Active and passive. Z359.0 defines “active fall protection system” as a fall protection system that requires workers “to wear or use fall protection equipment” (Section 2.2), and lists fall restraint, fall arrest, travel restriction, and administrative controls as examples. The Z359.0 standard, however, defines “passive fall protection system” as one “that does not require the wearing or use of fall protection equipment,” such as safety nets and guardrail systems (Section 2.113). Like the distinction that the Z359.0 standard draws between active and passive fall protection systems, OSHA believes that using the term “personal fall protection system” establishes the same type of distinction. That is, a personal fall protection system is one that employers must ensure that workers actively use to protect them, while a passive fall protection system, such as a guardrail, is one that does not require any action by workers to be safe, so long as employers maintain the system properly. OSHA believes this distinction is helpful, and that the regulated community recognizes and understands the distinction. Therefore, the term is carried forward in the final rule.

OSHA revised the final definition to expressly clarify the Agency’s intent in the proposed rule that personal fall protection systems include all components of those systems.

Positioning system (work-positioning system). The final rule, like the proposal, defines “positioning system” as a system of equipment and connectors that, when used with a body harness or body belt, allows an employee to be supported on an elevated vertical surface, such as a wall or window sill, and work with both hands free. Positioning systems also are called “positioning system devices” and “work-positioning equipment.”

The definition in the final rule is essentially the same as the definition in OSHA’s construction and shipyard

employment fall protection standards (§§ 1915.151(b), 1926.500(b)). The final rule also is similar to A10.32–2012 (Section 2.39, 2.40) and Z359.0–2012 (Section 2.120). Weatherguard Service, Inc. (Ex. 168) supported the proposed definition.

A note to the definition in Z359.0 explains that “a positioning system used alone does not constitute fall protection,” and that a separate system that provides backup protection from a fall is necessary (Section E2.120). Ellis (Ex. 155), who also commented on OSHA’s positioning system requirements, supported adding such a requirement to the final rule. OSHA did not incorporate this recommendation (see discussion in final paragraph (e) (positioning systems)). OSHA adopts the proposed definition with minor editorial changes.

Qualified, like in the proposed rule, describes a person who, by possession of a recognized degree, certificate, or professional standing, or who by extensive knowledge, training,⁷⁶ and experience has successfully demonstrated the ability to solve or resolve problems relating to the subject matter, work, or project. This definition is identical to the one in final § 1910.21(b). The final definition is almost identical to the definition applicable to OSHA’s construction standards (§ 1926.32(m)), and similar to the definition in the shipyard employment fall protection standard (§ 1915.151(b)). In addition, the definition in the final rule is consistent with the definition used in A10.32–2012 (Section 2.41).

The final rule, however, differs from the definition in the Powered Platforms standard (§ 1910.66, appendix C, Section I(b)) and Z359.0–2012. Those standards require that qualified persons have a degree, certification, or professional standing, *and* extensive knowledge, training and experience. OSHA explained in the proposed rule that to require qualified persons to meet the definition in the Powered Platforms standard would mean that the qualified person “would most likely need to be an engineer” (75 FR 28905).

Several commenters opposed the proposed definition of “qualified” and supported the definition of qualified in § 1910.66 and Z359.0 (Exs. 155; 193; 367). They also recommended revising the definition to specifically require that only engineers could serve as qualified persons. For example, Ellis said:

In America, anchorages are mostly guesswork and this does not do justice to

⁷⁶ “Training” may include informal, or on-the-job, training.

“the personal fall arrest system” term that OSHA is seeking to establish unless the engineering background is added. Furthermore the design of anchorages can easily be incorporated into architects and engineers drawings but is presently not because there is no requirement for an engineer. This simple change may result in saving over one half the lives lost from falls in the USA in my opinion (Ex. 155).

Penta Engineering Group added:

OSHA proposes to require that horizontal lifelines be designed, installed and used under the supervision of a qualified person and that they be part of a complete fall arrest system that maintains a factor of safety of two. To allow a person without an engineering degree and professional registration would not only be dangerous but would be contradictory to every current requirement for other building systems as required by the building codes. Further, in this specific instance, the design of a horizontal lifeline presents specific engineering challenges that should not be performed by anyone without the professional standing and experience to do so (Ex. 193).

Thomas Kramer of LJB, Inc., agreed, stating:

We take exception with the change from “AND” to “OR.” A person with a structural engineering degree does not necessarily know the full requirements (clearances, proper PPE selection, use and rescue procedures, etc.) of a personal fall arrest system. That knowledge can be obtained only through special training or experience in the subject matter. Vice versa, someone with knowledge of the system requirements may not know how to properly design an anchorage support and can only gain this knowledge through a professional degree. As stated in our previous comments, many building codes only allow a professional engineer to design and stamp a building design or changes to the loading of a structure. The explanation to make 1910 consistent with the existing construction and shipyard employment standard is not a good enough reason in our opinion. OSHA states that personal fall protection systems will “in some cases, [may] involve their design and use.” By using the word “OR,” the proposed regulation eliminates the need for an engineer’s involvement. The ANSI/ASSE Z359.0–2007 standard uses “AND”. These consensus standards are developed with a considerable level of thought and consideration and were recently vetted by the industry, so we suggest OSHA reconsider this change (Ex. 367).

OSHA did not adopt the commenters’ recommendations for several reasons. First, as discussed in the proposed rule, OSHA based the definition of “qualified” on the definitions in its construction and shipyard employment fall protection standards (§§ 1915.151(b); 1926.500(b)). For years, those definitions have been effective because they specify that employers must ensure the design, installation, and

use of components of personal fall protection systems (such as lifelines) protect workers from falls. Adopting the same definition as OSHA's other fall protection standards and final § 1910.21(b) also ensures consistency, which OSHA believes will increase both employer understanding and compliance with the requirement.

Second, the Agency believes the performance-based definition in the final rule gives employers flexibility in selecting a qualified person who will be effective in performing the required functions. The performance-based definition also allows employers to select the qualified person who will be the best fit for the particular job and work conditions. Employers are free to use qualified persons who have professional credentials and extensive knowledge, training, and experience, and OSHA believes many employers already do so.

Finally, the workers the employer designates or selects as qualified persons, the most important aspect of their qualifications is that they must have "demonstrated ability" to solve or resolve problems relating to the subject matter, work, and project. Having both professional credentials and knowledge, training, and experience will not protect workers effectively if the person has not demonstrated capability to perform the required functions and solve or resolve the problems in question.

When the person the employer designates as a qualified person has demonstrated the ability to solve or resolve problems, which may include performing various complex calculations to ensure systems and components meet required criteria, the qualifications of that person are adequate. OSHA also notes that an employer may need to select different qualified persons for different projects, subject matter, or work to ensure the person's professional credentials or training, experience, and knowledge are sufficient to solve or resolve the problems associated with the subject matter, work, or project. For example, the employer may determine that an engineer is needed for a particular project, and the final rule provides the employer with that flexibility. Accordingly, OSHA adopts the definition of qualified as proposed.

OSHA disagrees with Ellis' assertion that architects and engineers are not designing anchorages into drawings because, according to Ellis, § 1910.140 does not require qualified persons to be engineers. OSHA believes that building owners and others work with engineers and architects in the planning stage to design anchorage points into buildings

and structures so that the anchorages will effectively support personal fall protection systems used to perform work on the building. OSHA also believes that the number of building owners consulting engineers about the design of anchorages will increase under the final rule. Section 1910.27 of the final rule requires that, when employers use rope descent systems (RDS), building owners must provide information to employers and contractors ensuring that a qualified person certify building anchorages as being capable of supporting at least 5,000 pounds (29 CFR 1910.27(b)(1)). OSHA believes that building owners will likely consult and work with engineers to ensure that all building anchorages, including anchorages that support RDS and personal fall protection systems, meet the requirements in § 1910.27. Thus, OSHA does not believe it is necessary to limit the definition of "qualified" person to engineers to ensure that building owners include building anchors in building design plans.

Rope grab, like the proposed rule, is defined as a deceleration device that travels on a lifeline and automatically, using friction, engages the lifeline and locks to arrest a worker's fall. A rope grab usually employs the principle of inertial locking, cam or lever locking, or both.

The final rule is essentially the same as the definition in OSHA's Powered Platforms, construction, and shipyard employment fall protection standards (§§ 1910.66, appendix C, Section I(b); 1915.151(b); 1926.500(b)). The A10.32 and Z359.0–2012 standards do not define "rope grab," but the definition of "fall arrester" in Z359.0 (Section 2.60) is similar to the definition in this final rule. In addition, the explanatory note to the "fall arrester" definition identifies a "rope grab" as an example of a fall arrester. The A10.32–2012 standard requires rope grabs to automatically lock (Section 5.4.3). OSHA did not receive any comments on the proposed definition of "rope grab," and the final rule adopts it as proposed.

Safety factor. The final rule adds a definition for safety factor, also called a factor of safety. OSHA defines safety factor as the ratio of the design load and ultimate strength of the material. Generally, the term refers to the structural capacity of a member, material, equipment, or system beyond actual or reasonably anticipated loads; that is, how much stronger the member, material, equipment, or system is than it usually needs to be to support the intended load without breaking or failing. A safety factor is an additional

or extra margin of safety that provides assurance the system or equipment is able to support the intended load (e.g., a safety factor of two).

The new definition is the same as the one proposed in subpart D and is consistent with the one in § 1926.32(n). OSHA believes that adding this term will increase employer understanding and compliance with the requirements in this section.

Self-retracting lifeline/lanyard (SRL) is also a type of deceleration device. The final rule, like the proposal, defines an SRL as containing a drum-wound line that a worker can slowly extract from, or retract onto, a drum under slight tension during normal movement. At the onset of a fall, the device automatically locks the drum and arrests the fall.

The definition in the final rule is consistent with OSHA's Powered Platforms and construction fall protection standards (§§ 1910.66, appendix C, Section I(b); 1926.500(b)) and with Z359.0–2012 (Section 2.159) and A10.32–2012 (Section 2.46). There were no comments on the proposed definition, and the final rule adopts it as proposed.

Snaphook. The final rule, like the proposal, defines "snaphook" as a connector comprised of a hook-shaped body with a normally closed gate, or a similar arrangement, that the user may open manually to permit the hook to receive an object. When the user releases a snaphook, it automatically closes to retain the object. Opening a snaphook requires two separate actions, meaning the user must squeeze the lever on the back before engaging the front gate.

The final definition, like the proposal, identifies two general types of snaphooks—an *automatic-locking* type (also called self-locking or double locking), which the final rule permits employers to use, and a *non-locking* type, which the final rule prohibits. An automatic-locking type snaphook has a self-closing and self-locking gate that remains closed and locked until intentionally unlocked and opened for connection or disconnection. By contrast, a non-locking type has a self-closing gate that remains closed, but not locked until the user intentionally opens it for connection or disconnection (see discussion of § 1910.140(c)(9)).

The definition in the final rule is the same as the definition in OSHA's Powered Platforms and construction fall protection standards (§§ 1910.66, appendix C, Section I(b); 1926.500(b)). It also is consistent with Z359.0–2012 (Section 2.168) and A10.32–2012 (Sections 2.50, 2.50.1, 2.50.2). OSHA

received two comments on the snaphook definition, from CSG (Ex. 198) and ISEA (Ex. 185), both of which supported the proposed definition. OSHA adopts the definition as proposed.

Travel restraint (tether) line is a component of a travel restraint system. Specifically, the final rule, like the proposal, defines it as a rope or wire rope used to transfer forces from a body support to an anchorage or anchorage connector in a travel restraint system. The purpose of a travel restraint (tether) line is to secure workers in such a way as to prevent them from reaching an unprotected edge and falling off the elevated surface on which they are working.

The definition in the final rule is the same as the definition in OSHA's shipyard employment fall protection standard (§ 1915.151(b)). The definition in § 1915.151(b) notes that manufacturers do not necessarily design travel restraint lines to withstand forces resulting from a fall. OSHA did not receive any comments on the proposed definition, and the final rule adopts the definition as proposed.

Travel restraint system is a type of personal fall protection system that consists of a combination of an anchorage, anchorage connector, lanyard (or other means of connection), and body support that an employer uses to eliminate the possibility of a worker going over the edge of a walking-working surface. The final rule revises the proposed definition in two ways. First, the final rule defines "travel restraint system" to specify that it is a system a worker uses to eliminate the possibility of falling from the unprotected edge of an elevated walking-working surface. The proposed definition said the purpose of travel restraint systems was to "limit travel to prevent exposure to a fall hazard." OSHA believes the final definition more clearly explains the ultimate purpose of travel restraint systems than the proposed definition.

Second, the final definition deletes the second sentence of the proposed definition, which stated that a travel restraint system "is used such that it does not support any portion of the worker's weight; otherwise the system would be a positioning system or personal fall arrest system." OSHA believes the revised language in the final definition is sufficient to convey this requirement. In addition, OSHA addresses this issue in the discussion of § 1910.140(c)(14) below.

The definition in the final rule is consistent with the definition in Z359.0–2012 (Section 2.204) and

A10.32–2012 (Sections 2.53). The definition in A10.32 stresses that the purpose of a travel restraint system is to limit travel in such a manner that the user is not exposed to a fall hazard. OSHA did not receive comments on the proposed definition and finalizes the definition as discussed.

Window cleaner's belt, as defined in the final rule, is a component of a window cleaner's positioning system. It is a positioning belt that consists of a waist belt, an integral terminal runner or strap, and belt terminals.

The final rule revises the proposed definition to explicitly clarify that a window cleaner's belt is a component of a window cleaner's positioning system, and thus is designed to support the window cleaner on an elevated vertical surface. OSHA notes that a window cleaner's belt differs from a window cleaner's tool belt, which holds the window cleaner's tools and materials used for performing the job. Employers use the tool belt mainly for convenience of the window cleaner and not as safety equipment. The only commenter on the proposed definition, Weatherguard (Ex. 168), supported the proposed definition. Accordingly, the final rule adopts the definition with the revision discussed above.

Window cleaner's belt anchor (window anchor), as defined in the final rule, is a specifically designed fall-preventing attachment point permanently affixed to a window frame or a part of a building immediately adjacent to the window frame, for direct attachment of the terminal portion of a window cleaner's belt. Workers attach the terminals of the window cleaner's belt to the window anchors to prevent falling while cleaning windows.

OSHA based the final definition on the one in I–14.1–2001 (Section 2). OSHA's existing fall protection standards do not specifically address window cleaning operations, and do not define terms related to those operations. Weatherguard (Ex. 168), the only commenter, supported including the definition in the final rule. The final rule adopts the definition as proposed.

Window cleaner's positioning system, as defined in the final rule, is a system that consists of a window cleaner's belt secured to window anchors. The definition is similar to the general definition of positioning system in the final rule. Weatherguard (Ex. 168), the only commenter, supported the proposed definition and the definition is adopted as proposed.

Paragraph (c)—General Requirements

Paragraph (c) of the final rule specifies the general requirements

employers must ensure that each personal fall protection system meets. The general requirements in paragraph (c) are criteria for the common components of personal fall protection systems, such as connectors, anchorages, lanyards and body harnesses. Paragraphs (d) and (e) contain additional requirements for personal fall arrest systems and positioning systems, respectively.

The provisions in final paragraph (c) are drawn from or based on requirements in OSHA's personal fall protection standards, including Powered Platforms (§ 1910.66, appendix C), construction (§ 1926.502), and shipyard employment (§ 1915.160). They also are drawn from national consensus standards addressing fall protection, including Z359.1–2007, Z359.3–2007, A10.32–2012, and I–14.1–2001.

Paragraph (c)(1) of the final rule requires that employers ensure connectors used in personal fall protection systems are made of drop-forged, pressed or formed steel, or equivalent material. Final paragraph (c)(2) requires connectors to have corrosion-resistant finishes, as well as smooth surfaces and edges to prevent damage to interfacing parts of the personal fall protection system.

The requirements in paragraphs (c)(1) and (2) will ensure that connectors retain the necessary strength characteristics for the life of the fall protection system under expected conditions of use, and that the surfaces and edges do not cause damage to the belts or lanyards attached to them. Employers must not allow workers to use personal fall protection equipment if wear and tear reaches the point where equipment performance might be compromised. For example, corroded or rough surfaces can cause wear and tear on connectors and other components of personal fall protection system, which may reduce their strength.

Final paragraphs (c)(1) and (2) are consistent with OSHA's other fall protection standards, including Powered Platforms (§ 1910.66, appendix C, section I, paragraphs (c)(1) and (c)(2)); construction (§ 1926.502(d)(1), (d)(3), and (e)(4)); and shipyard employment (§ 1915.159(a)(1) and (2)). The Z359.1–2007 standard also contains similar requirements. There were no comments on the proposed provisions and OSHA adopts them without substantive change.

When employers use vertical lifelines, paragraph (c)(3) of the final rule requires that employers ensure each worker is attached to a separate lifeline. OSHA believes that allowing more than one

worker on the same vertical lifeline would create additional hazards. For example, if one worker falls, another attached worker might be pulled off balance and also fall. The final rule is consistent with OSHA's other fall protection standards (§§ 1910.66, appendix C, section I, paragraphs (c)(3) and (e)(5); 1926.502(d)(10); 1915.159(b)(1)). There were no comments on the proposed provision and it is adopted with only minor editorial changes.

Paragraphs (c)(4) and (5) of the final rule set minimum strength requirements for lanyards and lifelines used with personal fall protection systems. Paragraph (c)(4) requires that employers ensure lanyards and vertical lifelines have a minimum breaking strength of 5,000 pounds. Breaking strength refers to the point at which a lanyard or vertical lifeline will break because of the stress placed on it.

The final rule requires the same strength requirements for vertical lifelines and lanyards as OSHA's other fall protection standards (§§ 1910.66, appendix C, section I, paragraphs (c)(4); 1926.502(d)(9); 1915.159(b)(3)). The strength requirement also is the same as Z359.1–2007. OSHA believes the strength requirements in all of these standards provide an adequate level of safety. (OSHA notes that the final rule also requires that travel restraint (tether) lines be capable of supporting a minimum tensile load of 5,000 pounds (see discussion of paragraph (c)(14)).

The lanyards and vertical lifelines requirement in paragraph (c)(4) also includes self-retracting lifelines/lanyards (SRL) that allow free falls of more than 2 feet, as well as ripstitch, tearing and deforming lanyards. The proposed rule addressed those lifelines and lanyards in paragraph (c)(6); however, that paragraph duplicated paragraph (c)(4), and OSHA removed it from the final rule. Proposed paragraph (c)(4) also included a note, which OSHA re-designated as paragraph (c)(6) of the final rule (see discussion of § 1910.140(c)(6)).

Paragraph (c)(5) of the final rule, like the proposed rule, provides an exception to the 5,000-pound strength requirement for SRL that automatically limit free fall distance to 2 feet or less. The final provision allows a lower strength requirement because the fall arrest forces are less when free falls are limited to 2 feet. These lifelines and lanyards must have components capable of sustaining a minimum tensile load of 3,000 pounds applied to the device with the lifeline or lanyard in the fully extended position. Tensile load means a force that attempts to pull apart or

stretch an object, while tensile strength means the ability of an object or material to resist forces that attempt to pull apart or stretch the object or material.

Final paragraph (c)(5) is the same as OSHA's other fall protection standards (§§ 1910.66, appendix C, section I, paragraphs (c)(5); 1926.502(d)(13); 1915.159(b)(4)) and Z359.1–2007 (Section 3.2.8.7) and A10.32–2012 (Section 5.3.1). OSHA received comments on the proposed strength requirements in paragraphs (c)(4) and (5). As far back as the 1990 proposal, one commenter said that the strength requirements for lanyards and vertical lifelines were too high and would be difficult to maintain (75 FR 28907). OSHA acknowledged in the proposed rule that wear and deterioration to personal fall protection systems inevitably would occur from normal use of lanyards and lifelines, and that ultraviolet radiation, water, and dirt also can reduce the strength of lanyards and lifelines.

That said, OSHA believes that employers are able to purchase and maintain personal fall protection system and components that consistently meet the strength requirements in the final rule. These strength requirements have been in place for many years, and virtually all personal fall protection systems manufactured in or for use in the United States meet the requirements in paragraphs (c)(4) and (5). Since 1990, OSHA has not received any information indicating that the strength requirements should not be maintained. However, to ensure that lifelines and lanyards continue to comply with the requirements in paragraph (c)(5), paragraph (c)(18) of the final rule requires that employers inspect personal fall protection systems before each use and immediately remove worn or deteriorated systems and components from service. In addition, § 1910.132(a) requires that employers maintain personal protective equipment in reliable condition.

ISEA and CSG commented on the orientation of SRL with regard to lanyard and lifeline strength requirements. ISEA said:

[T]he horizontal or vertical orientation of a [self-retracting lanyard] is important because SRL used in a generally horizontal orientation rather than overhead may be subject to higher loadings and greater exposure to sharp or abrasive surfaces. Because the devices are typically anchored at waist height or below, free fall potential is greater (Ex. 185).

CSG agreed, adding that the higher loading of SRL used in horizontal positions reinforced the need for

additional training considerations for horizontally oriented SRL (Ex. 198). Both CSG and ISEA added that manufacturers generally include extra provisions for absorbing energy and protecting the lifeline from damage from building edges if the SRL will be used in a horizontal position. OSHA agrees that employers and competent persons should consider the horizontal or vertical orientation of a SRL in selecting and inspecting personal fall protection systems and training workers (§ 1910.30). OSHA notes that appendix C to § 1910.140 addresses the commenters' points so employers will be aware of the issue. OSHA also notes that paragraph (c)(11) of the final rule sets specific requirements when using horizontal lifelines. Neither commenter suggested that OSHA change the language of paragraph (c)(4) or (5). Accordingly, OSHA believes it is not necessary to revise either paragraph in the final rule.

Proposed paragraph (c)(6) also included a provision to establish strength requirements for SRL that do *not* limit free fall distance to not more than 2 feet, as well as for ripstitch, tearing, and deforming lanyards. OSHA proposed to require those types of lanyards and lifelines also be capable of sustaining minimum tensile loads of 5,000 pounds applied to the device when the lifeline or lanyard is in a fully extended position. The proposed provision was identical to requirements in OSHA's Powered Platforms (§ 1910.66, appendix C, Section I, paragraph (c)(5)), shipyard employment (§ 1915.159(b)(4)), and construction (§ 1926.502(d)(13)) fall protection standards. However, Z359.1–2007 and A10.32–2012 do not have a separate provision addressing self-retracting lifelines/lanyards that do not limit free fall distances.

OSHA requested comment on whether proposed paragraph (c)(6) was necessary, or whether paragraph (c)(4) of the final rule adequately addressed the issue (75 FR 28907). The Society of Professional Rope Access Technicians (SPRAT) said it would be acceptable to adopt either proposed provisions (c)(4) through (6) or the requirements in Z359.1 (Ex. 205). However, ISEA and CSG said proposed paragraph (c)(6) was not necessary, and, if OSHA retained the provision in the final rule, the Agency should remove SRL from it (Exs. 185; 198). OSHA believes that paragraph (c)(4) adequately addresses the issue of SRL that do not limit the free fall to a maximum of 2 feet plus ripstitch, tearing, and deforming lanyards; therefore, proposed paragraph (c)(6) is not necessary. Accordingly, OSHA

deleted proposed paragraph (c)(6) from the final rule.

In final paragraph (c)(6), OSHA replaces proposed paragraph (c)(6) with the requirement that a competent or qualified person must inspect each knot in lanyards and vertical lifelines, before a worker uses the lanyard or lifeline, to ensure that they still meet the minimum strength requirements in paragraphs (c)(4) and (5). This new requirement is based on the note OSHA included in proposed paragraph (c)(4) warning employers that the use of knots “may significantly reduce the breaking strength” of lanyards and vertical lifelines. The debate about whether knots should be permitted in lanyards and lifelines has been ongoing for at least 20 years. Although the proposal did not ban the use of knots, the Agency considered it, noting that Z359.1–2007 prohibits them: “No knots shall be tied in lanyards, lifelines, or anchorage connectors. Sliding-hitch knots shall not be used in lieu of fall arresters” (Section 7.2.1). The A10.32–2012 standard also prohibits the use of knots in lifelines, lanyards or other direct-impact components and also prohibits knots used for load-bearing end terminations (Sections 4.5.4 and 5.5.1.3).

As far back as the 1990 proposal, OSHA received comments supporting and opposing the use of knots. In the preamble to that proposed rule, OSHA said available information indicated that knots could be used safely in some circumstances, and that employers should be allowed the flexibility to use them as long as they verify that the strength requirements of the rule continue to be met. OSHA also noted that strength reduction can be a concern because the use of knots in lanyards and vertical lifelines can reduce breaking strength (75 FR 28907).

In this proposed rule, OSHA invited comment on whether the Agency should allow or prohibit the use of knots, or require a competent person to inspect all knots (75 FR 28907). Several commenters said OSHA should prohibit knots in personal fall arrest systems, noting they generally are no longer used in modern fall arrest applications (Exs. 185; 198; 251). Other commenters, including Martin’s Window Cleaning Corp. (Martin’s) (Ex. 222) and SPRAT (Ex. 205), opposed a prohibition on the use of knots. Martin’s said, “A properly tied knot is much stronger than a swedge or splice,” which the proposed rule did not prohibit (Ex. 222). SPRAT said appropriately tied knots were useful at the end and throughout rope spans, and cited Cordage Institute data indicating knots commonly used in life-safety systems had an efficiency range of

75–90 percent (Ex. 205). SPRAT also said their employers require that competent persons inspect all knots tied in industrial rope access systems. They added that the rule must require that workers be trained in uses, limitations, and proper inspection techniques of knots and hitches.

At the hearing on the proposed rule, the American Wind Energy Association (AWEA) also opposed banning the use of knots. Grayling Vander Velde, an AWEA member, said, “Knots are widely used in industrial rope access for competent persons trained and certified in their proper use and limitations,” and “line failure due to installation of knots has not shown to be the cause of mainline or backup line failures” (Ex. 329 (1/21/2011, pgs. 19–20)). He stated that ropes used for fall arrest must meet the 5,000-pound minimum strength requirement in the final rule. Also, he noted that SPRAT’s training covers the issue of possible strength reduction in knotted lanyards.

After considering the record as a whole, OSHA continues to believe that knots can be used safely in certain situations, and that the worker making the knot must be adequately trained to know the strength of the rope being used and take into consideration any strength reduction that may occur if a knot is used. As the commenters pointed out, any rope that has a knot must still meet the strength requirements in final paragraphs (c)(4) and (5) to ensure that workers have an appropriate level of safety (Ex. 205). To ensure that lanyards and vertical lifelines that have knots are safe, OSHA added a new requirement in paragraph (c)(6) of the final rule specifying that a competent or a qualified person must inspect each knot to ensure that it meets the minimum strength requirements before any worker uses the lanyard or lifeline. OSHA believes the additional requirement will preserve employer flexibility while providing an adequate level of safety.

Paragraphs (c)(7) through (10) of the final rule establish criteria for D-rings, snaphooks, and carabiners, which are devices used to connect or couple together components of personal fall protection systems. OSHA added “carabiners” to these final paragraphs because they are a type of connector commonly used in currently-manufactured personal fall protection systems. Paragraph (c)(7) of the final rule requires that D-rings, snaphooks, and carabiners be capable of sustaining a minimum tensile load of 5,000 pounds. OSHA believes these devices, like lanyards and vertical lifelines, must be able to sustain 5,000-pound loads to

ensure worker safety. If the connectors cannot sustain the minimum tensile load, it makes no difference what strength requirements the other components of the system can meet because the system may still fail.

Final paragraph (c)(7) is the same as the strength requirements in OSHA’s other fall protection standards (§§ 1910.66, appendix C, Section I, paragraph (d)(6); 1915.159(a)(3); 1926.502(d)(3)). OSHA did not receive any comments on the proposed provision and is adopting it as discussed.

Paragraph (c)(8) of the final rule requires that D-rings, snaphooks, and carabiners be proof tested to a minimum tensile load of 3,600 pounds without cracking, breaking, or incurring permanent deformation. OSHA also added a new requirement to final paragraph (c)(8) specifying that the gate strength of snaphooks and carabiners also must be proof tested to 3,600 pounds in all directions. Since proof testing has been the industry standard since 2007 (Z359.1–2007, Section 3.2.1.7), OSHA believes that connectors of this type already in use meet the requirements of paragraph (c)(8) and no grandfathering is necessary.

The 3,600-pound strength requirement ensures that D-rings, snaphooks, and carabiners meet a safety factor of at least two when used with body harnesses. This strength requirement will, in turn, limit maximum fall arrest forces to 1,800 pounds. Final paragraph (c)(8) is similar to requirements in OSHA’s Powered Platform, construction, and shipyard employment fall protection standards (§§ 1910.66, appendix C, Section 1, paragraph (c)(7); 1915.159(a)(4); 1926.502(d)(4)), but those standards do not require proof testing gate strength. The Z359.12–2009 standard is the same as proposed paragraph (c)(8).

A number of commenters supported the proposed requirement (Exs. 155; 185; 198). Several commenters also recommended that OSHA include two additions to the proposed requirement: (1) Proof testing the gate strength of carabiners and snaphooks; and (2) proof testing the gate strength in all directions (Exs. 155; 185; 198). ISEA and CSG said that past interpretations of snaphook strength requirements led to confusion, and that including a gate strength requirement would help to clarify this issue (Exs. 185; 198).

Ellis said adding a requirement that the gate strength of snaphooks and carabiners also be proof tested to 3,600 pounds would make paragraph (c)(8) consistent with the Z359.12–2009 standard, and be more protective than

the A10.32–2004 standard, which prescribes a lower gate strength (Ex. 155). Ellis noted that including the recommended additions also would help employers “avoid incidents from bent hook gates to loose gate fly-by to jamming open scenarios that have plagued the industry for decades when the strength is 220 lbs/350 lbs as in the A10.32–2004” (Ex. 155). OSHA agrees that the addition will provide greater protection for workers.

Ellis also recommended that OSHA require proof testing snaphook and carabiner gate strength “in all directions” (Ex. 155). The purpose of proof testing gate strength in all directions is to ensure that no matter in which direction the pressure is applied, the connector gate will not fail. Such proof testing will provide greater protection for workers, therefore, OSHA added the requirement to proof test the gate strength of snaphooks and carabiners in all directions. Since this testing has been industry practice for several years (see Z359.1–2007, Section 3.2.1.7), OSHA does not believe that employers will have difficulty complying with the new requirement in paragraph (c)(8).

Paragraph (c)(9) of the final rule requires employers to use automatic locking snaphooks and carabiners in personal fall protection systems. Automatic locking snaphooks and carabiners require at least two separate, consecutive actions to open, which reduce the danger of “rollout” (*i.e.*, inadvertent opening and disconnecting of components). Non-locking snaphooks are prohibited in a personal fall protection system.

Final paragraph (c)(9) is consistent with OSHA’s shipyard employment and construction fall protection standards (§§ 1915.159(a)(5); 1926.502(d)(5)). In addition, Z359.12–2009 (Section 3.1.1.3) and A10.32–2012 (Sections 2.12 and 2.50.1) both require the use of locking snaphooks and carabiners for personal fall protection systems.

In the proposed rule, OSHA explained that as far back as the 1990 proposed rule, commenters expressed widespread support for prohibiting non-locking snaphooks (75 FR 28908). In OSHA’s rulemaking on fall protection in the construction industry, several commenters said the rule should mandate the use of locking snaphooks, citing the rollout problems experienced with non-locking (single-action) snaphooks (59 FR 40672, 40705 (8/9/1994)). Those commenters also provided information indicating that locking snaphooks are superior to non-locking snaphooks in minimizing rollout. Based on that and other information in that

rulemaking record, OSHA determined that it was necessary to require the use of locking snaphooks in personal fall protection systems used in the construction industry, finding that “in general, locking snaphooks provide a higher level of protection to workers than the single-action (non-locking) type of snaphooks” (59 FR 40705).

Likewise, OSHA has determined that locking snaphooks and carabiners are necessary to protect employees in general industry. In the proposed rule, OSHA asked for comment on whether the requirement should be phased in, but received no comment on the issue. OSHA does not believe it is necessary to provide a phase-in period, because the construction rule has been in place since 1998. Accordingly, OSHA believes that manufacturers currently are making personal fall protection systems available with automatic locking snaphooks and carabiners, and most employers already are using snaphooks and carabiners that comply with the final rule.

Paragraph (c)(10) of the final rule prohibits employers from using snaphooks or carabiners for certain connections unless they are designed for that connection. Accordingly, the final rule specifies that employers may connect snaphooks or carabiners to the following objects *only* if the snaphooks and carabiners are designed to be connected:

- Directly to webbing, rope, or wire rope;
- To each other;
- To a D-ring to which another snaphook, carabiner, or connector is attached;
- To a horizontal lifeline; or
- To any object that is incompatibly shaped or dimensioned in relation to the snaphook or carabiner such that unintentional disengagement could occur when the connected object depresses the snaphook or carabiner gate and allows the components to separate.

Final paragraph (c)(10) is the same as OSHA’s construction and shipyard employment fall protection standards (§§ 1915.159 (a)(6); 1926.502(d)(6)). The Powered Platforms standard addresses the connection compatibility issue a little differently than this final rule, requiring that snaphooks “be sized to be compatible with the member to which they are connected so as to prevent unintentional disengagement” of the snaphook (§ 1910.66, appendix C, Section I, paragraph (d)(8)). Similarly, the Z359.1–2007 standard requires: “Snaphooks and carabiners shall be compatibly matched to their associated connectors to reduce the possibility of

rollout . . . Snaphooks and carabiners shall not be connected to each other” (Section 7.2.2.). Explanatory notes accompanying this provision state that multiple connections (*e.g.*, two snaphooks, snaphook and webbing) into a single ring are not recommended (Section E7.2.2).

OSHA believes that the final rule will help to reduce the potential of rollout. Certain connections, such as ones that are incompatibly sized or dimensioned, increase the likelihood of rollout, and OSHA believes the provision is needed to provide adequate assurance of worker safety. Accordingly, OSHA adopts the proposed provision, with the addition of “carabiners,” a commonly used connector.

In paragraph (c)(11) of the final rule, like the proposal, OSHA establishes two requirements for horizontal lifelines. The provision specifies that employers must ensure horizontal lifelines are: (1) Designed, installed, and used under the supervision of a qualified person (paragraph (c)(11)(i)); and (2) are part of a complete personal fall arrest system that maintains a safety factor of at least two (paragraph (c)(11)(ii)).

Paragraph (c)(11) is the same as OSHA’s Powered Platforms (§ 1910.66, appendix C, Section I(c)(9)) and construction fall protection standards (§ 1926.502(d)(8)). In addition, A10.32–2012 contains similar requirements (Section 4.4). Although Z359.1–2007 does not address horizontal lifelines specifically, it provides: “A PFAS [personal fall arrest system] which incorporates a horizontal lifeline (outside the scope of this standard) shall be evaluated in accordance with acceptable engineering practice to determine that such system will perform as intended” (Section 3.1.4).

OSHA believes the requirements in paragraph (c)(11) are necessary because horizontal lifelines present unique safety issues. For example, horizontal lifelines may be subject to greater impact loads than the loads imposed by other attached components. Horizontal lifelines also result in potentially greater fall distances than some other fall protection devices. Even a few additional feet of free fall can increase fall arrest forces significantly, possibly to the point of exceeding the strength of the system. In addition, forces applied in a perpendicular direction to a horizontal lifeline create much larger forces at the anchorages. The potential for increased fall arrest forces and impact loads associated with horizontal lifelines explains the need for employers to ensure that personal fall arrest systems used with horizontal lifelines maintain a safety factor of at

least two. (See discussion of horizontal lifelines in appendix C to § 1910.140, section (j).)

OSHA received one comment on the proposed provision. Ellis said OSHA should require that horizontal lifelines be positioned overhead when the personal fall arrest system is made ready for use because of increased forces when the line is at waist level. He added, "Due to stretch the fall factor increases fall distance when the line is below shoulder height" (Ex. 155). OSHA recognizes that using horizontal lifelines at waist level may be unavoidable in some circumstances. Requiring that a qualified persons design, install, and supervise the use of horizontal lifelines with personal fall arrest systems helps to ensure that issues such as the positioning of horizontal lifelines will be properly considered and resolved before the personal fall arrest system is used.

Paragraph (c)(12) of the final rule, like the proposed rule, requires that employers ensure anchorages used to attach to personal fall protection equipment are independent of any anchorage used to suspend workers or work platforms. This requirement ensures that if the anchorage holding other equipment (such as a powered platform or RDS) fails, the worker will still be protected by the separate, independent anchorage to which the personal fall protection system is secured. The purpose of the requirement, which the shipyard employment and construction fall protection standards also require (§§ 1915.159(a)(8); 1926.502(d)(15)), is to ensure that anchorages used to suspend workers or work platforms are not the anchorages that workers use for their personal fall protection system.

The Industrial Truck Association (ITA) said the provision was not a workable requirement for mobile work platforms such as those on powered industrial trucks:

On powered industrial trucks that have elevating platforms, such as high-lift order pickers, the anchorage for the lanyard that comprises part of the personal fall protection equipment is necessarily a part of the overhead guard or some other structural member that elevates with the operator platform and through the same mechanism (the lift chains) as the platform. This is inherent in mobile equipment, which cannot depend on some separate fixed anchorage point for the personal fall protection equipment. The concern is that the anchorage used for attaching the personal protective equipment, since it moves up and down with the operator platform, could be considered not "independent" of the anchorage being used to support the platform. Since OSHA obviously did not intend by the proposed

revision to eliminate the use of high-lift order pickers or other powered industrial truck platforms, it appears that 1910.140(c)(12) requires a clarification for mobile equipment (Ex. 145).

OSHA agrees with the issue the commenter raised and exempts mobile work platforms on powered industrial trucks from the requirement in final paragraph (c)(12) that anchorages be independent. Therefore, OSHA has added language to the final rule to address anchorages used to attach to personal fall protection equipment on mobile work platforms on powered industrial trucks. The new language specifies that those anchorages must be attached to an overhead member of the platform, at a point located above and near the center of the platform. OSHA modeled this language on the anchorage requirements in the national consensus standard on powered industrial trucks (ANSI/ITSDF B56.1–2012, Safety Standard For Low Lift and High Lift Trucks (Ex. 384; Section 7.37)).

Paragraph (c)(13) of the final rule adopts strength requirements for anchorages for personal fall protection systems, and includes a performance-based alternative. The final provision, like the proposal, requires that anchorages either (1) be capable of supporting at least 5,000 pounds for each worker attached, or (2) be designed, installed, and used under the supervision of a qualified person as part of a complete personal fall protection system that maintains a safety factor of at least two. The anchorage strength requirement applies to personal fall arrest, travel restraint, and positioning system anchorages, but not to window cleaner's belt anchors, which are addressed separately in paragraph (e).

Paragraph (c)(13) is the same as the personal fall protection system anchorage requirement in OSHA's Powered Platforms, shipyard employment and construction fall protection standards (§§ 1910.66, appendix C, Section (c)(10); 1915.159(a)(9); 1926.502(d)(15)). The A10.32–2012 standard also contains similar requirements (Section 5.1.1). Although the anchorage requirements in Z359.1–2007 and I–14.1–2001 are similar to the final rule, they differ to some extent. For example, the Z359.1 standard requires:

Anchorages selected for [personal fall arrest systems] shall have a strength capable of sustaining static loads, applied in the directions permitted by the PFAS, of at least: (a) Two times the maximum arrest force permitted on the system, or (b) 5,000 pounds (22.2kN) in the absence of certification. When more than one PFAS is attached to an anchorage, the anchorage strengths set forth

in (a) and (b) above shall be multiplied by the number of personal fall arrest systems attached to the anchorage (Section 7.2.3).

The I–14.1 standard requires that all components of personal fall arrest systems, including anchorages, comply with the Z359.1 standard, with some exceptions, such as window cleaner's belts (Section 9.2.2(a)).

OSHA did not receive any comments opposing proposed paragraph (c)(13), and Ameren specifically supported the performance language alternative: "Ameren agrees with this language so as to allow use to determine suitable anchorage points because of capacity and not be restricted due to other designations of the equipment" (Ex. 189).

As discussed above, OSHA believes that all of the strength requirements in the final rule are necessary to provide a reasonable margin of safety for workers. At the same time, the final rule gives employers flexibility in meeting the anchorage strength requirement in specific circumstances. The final rule does not require a 5,000-pound anchorage point in every situation. An employer may use an anchorage that meets a different strength, provided that (1) the anchorage is part of a complete fall protection system, (2) the personal fall protection system maintains a safety factor of at least two, and (3) the anchorage is designed, installed, and used under the supervision of a qualified person.

The Agency anticipates that even employers who cannot achieve 5,000-pound anchorage strength should have no difficulty meeting the alternative 2:1 safety factor. For example, I–14.1–2001 requires that anchorages for positioning systems be capable of supporting 3,000 pounds or at least twice the potential impact load of a worker's fall, whichever is greater (Section 9.2.3(b)). The I–14.1 requirement has been in place for more than 10 years, and employers are familiar with the standard.

Ellis recommended that OSHA require employers using the alternate anchorage strength procedures in (c)(13) to document the anchorage "with at least a sketch or engineering drawing" because "anchorages are mostly guesswork" (Ex. 155). OSHA believes that the requirement in paragraph (c)(13), that qualified persons design, install, and supervise the use and maintenance of anchorages, is sufficient, and will be more effective in protecting workers than documentation by a person who may not have the qualifications of a qualified person. Qualified persons, as paragraph (b) specifies, must possess the type of

qualifications (*i.e.*, recognized degree, certificate, or professional standing or extensive knowledge, training, and experience) that makes them capable of designing anchorages that successfully meet the requirements of the final rule. Or, the qualified person must have demonstrated ability to solve and resolve the issues relating to the subject matter, work, or work project. Final paragraph (c)(13) requires that the qualified person supervise the use of the anchorages, which will ensure the qualified person oversees maintenance of the anchorages so they remain in safe and useable condition. OSHA believes this supervision will go further in providing worker protection than anchorage sketches or drawings.

OSHA notes that an employer may use more than one qualified person to comply with the final rule. For example, some employers may choose to have an outside qualified person design the anchorages to meet the requirements of the final rule and an in-house, on-site qualified person to supervise their installation and use.

Paragraph (c)(14) of the final rule, like the proposed rule, requires that restraint lines in travel restraint systems be capable of sustaining a tensile load of at least 5,000 pounds. OSHA's existing fall protection standards do not include any requirements that specifically address travel restraint systems or lines. The requirement is drawn from two national consensus standards: (1) The A10.32–2012 standard specifies that component parts of travel restraint systems be designed and manufactured to meet the standard's requirements for personal fall arrest systems (Section 4.6.1); and (2) the Z359.3–2007 standard requires that positioning and travel restraint lanyards be capable of sustaining a minimum breaking strength of 5,000 pounds (Section 3.4.8).

OSHA believes the strength requirement for travel restraint lines in final paragraph (c)(14) is necessary for several reasons. First, the requirement ensures that the restraint line provides adequate protection if a restraint line is ever used as a lifeline. For example, if a travel restraint system is not rigged properly or is inadvertently used with a personal fall arrest system, and the worker falls off the walking-working surface, the restraint line essentially becomes a lifeline. Because of this possibility, OSHA believes it is necessary that travel restraint lines have the same 5,000-pound minimum breaking strength required of personal fall protection system lifelines and lanyards (see paragraph (c)(4)).

Second, according to CSG (Ex. 329 (1/18/2011, p. 110)) and Mine Safety

Appliances (MSA) (Ex. 329 (1/18/2011, p. 199)) travel restraint systems (including lines and lanyards) currently are designed and manufactured to support a 5,000 pound load. Further, MSA said they were not aware of any company that still manufactures travel restraint lines that support only 3,000 pounds.

Finally, setting the strength requirement at 5,000 pounds for travel restraint lines makes the provision consistent with other strength requirements in § 1910.140 for components of personal fall protection systems (*e.g.*, D-rings, snaphooks, carabiners, anchorages (paragraphs (c)(7) and (13))). OSHA adopts the provision as discussed.

Paragraph (c)(15) of the final rule requires that employers ensure lifelines are not made of natural fiber rope. Natural fiber rope of the same size is weaker than its synthetic counterpart and may burn under friction. When the employer uses polypropylene rope, the final rule requires that it must contain an ultraviolet (UV) light inhibitor. Final paragraph (c)(15) is consistent with OSHA's Powered Platforms, shipyard employment, and construction fall protection standards (§§ 1910.66, appendix C, Section (c)(11); 1915.159(c)(2); 1926.502(d)(14)). Those standards specify that ropes and straps (webbing) used in lanyards, lifelines, and strength components of body belts and body harnesses be made from synthetic fibers or, with the exception of the construction standard, wire rope; however, those standards do not require that lifelines made of polypropylene rope contain a UV light inhibitor.

The final rule provision also is consistent with Z359.1–2007 and with A10.32–2012, which provide useful guidance to help employers meet the requirement in final paragraph (c)(15). For example, the Z359.1 standard provides: "Rope and webbing used in the construction of lanyards shall be made from synthetic materials of continuous filament yarns made from light and heat resistant fibers having strength, aging, and abrasion resistant characteristics equivalent or superior to polyamides" (Section 3.2.3.1). The A10.32 standard specifies, "Harnesses, lanyards, lifelines and other load-bearing devices shall not be made of natural fibers (including, but not limited to, cotton, manila and leather)" (Section 4.5.5). The I–14.1–2001 standard requires that all personal fall arrest systems used in window cleaning operations comply with Z359.1, and prohibits ropes made entirely of polypropylene (Sections 6.8, 9.2.2(a)). In addition, the standard requires that all

rope and webbing used in suspending RDS seat boards be made of synthetic fiber, preferably nylon or polyester (Section 14.3(d)).

Like the Z359.1 standard, OSHA recognizes that degradation due to exposure to ultraviolet light can be a serious problem, especially for polypropylene rope. However, OSHA believes that polypropylene rope has certain advantages compared to other synthetic materials. Polypropylene rope is strong and flexible, and may be less costly than rope made of other materials. Moreover, many newer polypropylene ropes are made with UV light inhibitors, so employers can use polypropylene rope without the risk of degradation from UV light. The Agency believes the final rule provides adequate protection for workers while embracing technological advances that give employers greater flexibility in complying with paragraph (c)(15). Additionally, OSHA removed "carriers" from the final provision. Carriers are used exclusively in ladder safety systems, which are covered in § 1910.23, and not in personal fall protection systems. OSHA did not receive any comments on the proposed provision, and adopts it as discussed.

Paragraph (c)(16) of the final rule, like the proposed rule, requires that all personal fall protection systems and components be used only for worker fall protection. Paragraph (c)(16) also prohibits personal fall protection systems from being used for any other purpose, such as hoisting materials or equipment. The final rule applies to all personal fall protection systems, including personal fall arrest systems, positioning devices and travel restraint systems and components such as anchorages, harnesses, connectors, and lifelines.

The final rule is similar to OSHA's Powered Platforms, shipyard employment and, construction fall protection standards (§§ 1910.66, appendix C, Section I, paragraph (c)(6); 1915.159(c)(9); 1926.502(d)(18)).

OSHA received one comment on the proposed requirement. Although Verallia "agree[d] with OSHA's goal of using . . . personal fall protection equipment only for its intended purpose," they said:

[A]nchorage points—while clearly performing a function related to the use of personal fall protection—fall outside the intended goal of preserving intact the equipment itself. In other words, anchorage points are designed for and have many uses outside of fall protection in industrial settings. Their occasional use for tasks other than personal fall protection is consistent with their design (Ex. 171).

OSHA agrees anchorages have uses other than for personal fall protection. Anchors are used for suspended work platforms, rope descent systems, and other equipment. For example, using a structural beam as an anchorage does not mean the structural beam can never be used as a structural member. OSHA intends this provision to apply to those components that would typically be found in a personal fall protection kit, *i.e.*, a body harness, lanyards, and connectors. Structural members used as anchorage points will obviously continue to be structural members and do not fall under this provision. However, for example, if a worker is using appropriate webbing tied around a structural member as an anchor point for personal fall protection, that webbing must be used only for personal fall protection, both at that time, and in the future. The webbing (and harness, lanyard, and connectors) must not be used for any other purpose at any other time, such as hoisting materials and equipment.

Paragraph (c)(17) of the final rule, like the proposed rule, requires that any personal fall protection system or its component subjected to impact loading must be removed from service immediately. This requirement applies to impact loading due to a free fall, but not to impact loading during static load testing. The final rule also specifies that the employer must not use the system or component again until a competent person inspects the system or component and determines that it is not damaged and is safe to use for worker personal fall protection.

The final rule is the same as the Powered Platforms, shipyard employment and construction fall protection standards (§§ 1910.66, appendix C, Section I, paragraph (e)(7); 1915.159(c)(6); 1926.502(d)(19)). The 2359.1–2007 (Section 5.3.4) and A10.32–2012 (Section 3.4) standards also require that impact loaded systems and components be removed from service; however, neither standard specifies requirements that allow or prohibit reuse of such equipment.

OSHA believes that paragraph (c)(17) will ensure that employers implement procedures for inspection and evaluation of impact-loaded personal fall protection systems and components to prevent reuse of damaged equipment. OSHA believes that the requirements in paragraph (c)(17), as well as the other requirements in the final rule, provide sufficient safeguards to allow the reuse of impact-loaded personal fall protection systems after the competent person inspects and repairs or replaces the damaged components.

The final rule provides the following safeguards to ensure the dangers of impact-loaded personal fall protection systems are addressed properly before reuse:

- Paragraph (c)(18) of the final rule, discussed below, requires that employers ensure personal fall protection systems are inspected for damage before each use, and remove defective components from service;
- Section 1910.30 of the final rule requires that each worker be trained in the proper inspection of fall protection equipment; and
- Appendix C to § 1910.140 provides useful information on inspecting fall protection equipment and components.

OSHA requested comment on whether the proposed approach provides adequate protection. In particular, OSHA asked for comment on whether the final standard should require destruction of ropes, lanyards, belts, and harnesses subjected to impact loading (75 FR 28909). Impact loading can cause damage to fibers that cannot be discovered easily. OSHA notes these components are relatively inexpensive to replace.

OSHA received comments supporting the proposed requirement (Exs. 185; 198; 251). ISEA (Ex. 185) and CSG (Ex. 198) both said that manufacturers commonly indicate in user instructions and product labels how to handle personal fall protection equipment after an impact, and recommended that: “OSHA should err on the side of worker protection and recommend that when components of personal fall arrest systems such as ropes, lanyards, or harnesses are impact loaded, they should be permanently taken out of service and disposed of” (Ex. 185). ISEA and CSG pointed out that some fall protection components have an impact load indicator that alerts users when a product must be taken out of service (Exs. 185; 198). This device makes it easy for employers to know when they need to remove personal fall protection systems and components from service and replace them. One commenter on the 1990 proposed rule said that only manufacturers should inspect systems to determine if they are suitable for reuse (Ex. OSHA–S057–2006–0680–0048).

By contrast, Edison Electric Institute (EEI) opposed requiring removal of equipment subjected to impact loading. EEI said, “Inspection by a competent person is adequate to determine whether the component is still functional” (Ex. 207). Similarly, SPRAT opposed the destruction of equipment that is “retired” (Ex. 205).

OSHA believes that impact loading may adversely affect the integrity of personal fall protection systems, but also recognizes that many other factors can affect a system’s potential capability for reuse after impact loading. These factors include the type of deceleration device used, and the length of the fall. For example, a short fall of one foot may not damage the harness, but a long fall, such as six feet or more, may damage or even destroy the harness. OSHA believes that if an impact-loaded system or component is damaged or fails the employer must remove it from service immediately so a competent person can inspect the system or component and determine whether it can be reused for worker fall protection. However, when a competent person’s careful inspection of the entire system and evaluation of the factors involved in the fall indicates no damage has occurred, and the personal fall protection system or component continues to meet the strength requirement and other criteria necessary for continued use, OSHA does not believe it is necessary that employers permanently remove the system or component from use. OSHA notes that the employer should be allowed to reuse such system and components. In addition, OSHA believes that a competent person, as defined in paragraph (b) of the final rule, has the ability to carefully inspect the personal fall protection system and its components, evaluate the various factors involved in the fall, and make a determination about whether the equipment is safe for reuse. Moreover, the competent person has the authority to take prompt corrective action, including prohibiting the reuse of the equipment or any component that may have been damaged.

Paragraph (c)(18) of the final rule, like the proposal, requires that before initial use during each workshift, personal fall protection systems must be inspected for mildew, wear, damage, and other deterioration. The provision also requires that employers remove from service any defective component.

Final paragraph (c)(18) clarifies two key terms: “before each use” and “defective component.” Proposed paragraph (c)(18) specified that workers must inspect personal fall protection systems “before each use.” The final rule expressly clarifies that OSHA’s intention in the proposed rule was that workers inspect their personal fall protection systems before initial use during each workshift. Thus, if the personal fall protection system is used in more than one workshift during a day, the system must be reinspected at the start of each of those workshifts.

OSHA also clarifies that the term “defective component,” which appendix C to § 1910.140 refers to as a “significant defect,” means damage or deterioration that affects the function or strength of the system or component.

The final rule is generally consistent with OSHA’s Powered Platforms, construction, and shipyard employment standards (§§ 1910.66, appendix C, Section I(f); 1915.159(c)(5); 1926.502(d)(21)), as well as with Z359.1–2007 (Section 6.1) and A10.32–2012 (Section 4.1).

OSHA believes that paragraph (c)(18), like paragraph (c)(17), will ensure that employers have a procedure in place for inspecting personal fall protection systems and components and removing defective, damaged, or weakened components from service. Appendix C to § 1910.140 provides useful information to help employers with the inspection requirement in the final rule, including a list of the types of defects that can require removal. (See appendix C to § 1910.140, Section (g)).

OSHA received only one comment on inspection of personal fall protection systems. Verallia recommended that OSHA require “prior to use, each employee must visually inspect the anchorage points for wear and obvious deformities” (Ex. 171). OSHA does not believe it is necessary to add the language in Verallia’s recommendation because paragraph (c)(18) already requires that employers inspect anchorage points. Paragraph (c)(18) requires that employers inspect personal fall protection systems. The definition of personal fall protection system in the final rule identifies personal fall arrest systems, positioning systems, and travel restraint systems as examples of personal fall protection systems. The definitions of each of those systems explain that they consist of various components (“a system of equipment”), including anchorages. Therefore, employers must ensure that the inspection covers every component of the personal fall protection system, including anchorages, so the entire system is safe to use.

Paragraph (c)(19) of the final rule requires employers to ensure that ropes, lanyards, harnesses, and belts used for personal fall protection are compatible with the connectors being used. Although the final rule does not define “compatible,” Z359.0–2012 defines compatible as follows:

Capable of orderly, efficient integration and operation with other elements or components in a system, without the need of special modification or conversion, such that the connection will not fail when used in the manner intended (Section 2.29).

OSHA believes compatibility between personal fall protection components and connectors is essential to prevent hazards such as rollout, exceeding system strength, and long free fall distances that can increase fall arrest forces significantly. For example, a lifeline or harness can disengage from a connector if its size or dimension is incompatibly sized or configured for use with the connector.

In addition, the Agency has found that it is common practice for employers to interchange or replace components of personal fall protection systems (*e.g.*, lanyards, connectors, lifelines, deceleration devices, body harnesses, body belts) with components produced by other manufacturers. Final paragraph (c)(19) gives employers flexibility to continue this practice when they need to replace personal fall protection components. At the same time, the final rule ensures that workers are protected from rollout and other fall hazards regardless of whether the employers uses replacement components from the same or a different manufacturer.

Appendix C to final § 1910.140 provides important information to help employers ensure they maintain compatibility when replacing personal fall protection components. For example, the appendix cautions: “Any substitution or change to a personal fall protection system should be fully evaluated or tested by a competent person to determine that it meets applicable OSHA standards before the modified system is put to use” (§ 1910.140, appendix C, Section (d)). OSHA notes that final paragraph (c)(19) and appendix C are consistent with Z359.1–2007 (Section 7.1.7), which requires that connectors, regardless of whether they are integral elements of the personal fall protection system, individual components, or replacements produced by the same or different manufacturers, must be suitably configured to interface compatibly with associated connectors which will be attached to them.

Final appendix C to § 1910.140 states the ideal way for employers to ensure the compatibility of components of personal fall protection systems is to supply workers with complete systems (appendix C to § 1910.140, Section (d)).

The final rule is similar to the shipyard employment fall protection standard, which requires that system components be compatible with “their hardware” (§ 1915.159(c)(3)). Both Z359.1–2007 and A10.32–2012 include similar compatibility requirements. For example, A10.32 specifies: “All equipment used in a fall protection system shall be compatible to limit force

levels, maintain system strength, and prevent accidental disengagement” (Section 1.4.3; *see also* Z359.1–2007 (Section 7.1.1)). These national consensus standards also require that competent persons ensure personal fall protection systems comprised of components and subsystems produced by different manufacturers are compatible (Z359.1–2007 (Section 7.1.10); A10.32–2012 (Section 7.4)).

Commenters raised two concerns about proposed paragraph (c)(19). First, ISEA and CSG seem to imply that the compatibility requirement in final paragraph (c)(19) is not necessary (Exs. 185; 198). For support, they point out that Z359.12 (Section 7.1) requires that snaphooks and carabiners be designed to prevent “forced rollout,” which ISEA and CSG appear to believe is an adequate solution without requiring that employers also comply with paragraph (c)(19). In addition, ISEA and CSG pointed out that manufacturers currently are designing connectors to prevent forced rollout. However, the explanatory note in Z359.12 states:

While connectors which are compliant with ANSI/ASSE Z359.12 reduce the possibility or risk of failure as a result of incompatible connections, they do not eliminate it (Z359.12–2009 (Section E7.1)).

Moreover, OSHA notes that rollout is not the only hazard that component incompatibility can cause. The A10.32–2012 standard specifies that components of personal fall protection systems must be compatible in order “to limit force levels, maintain system strength, and prevent accidental disengagement” (Section 1.4.3). Accordingly, OSHA believes the component compatibility requirement in final paragraph (c)(19) is necessary because it will protect workers from all of those hazards.

Second, ASSE argues that it is not feasible to eliminate incompatible connections:

The reality is that there are too many non-certified anchorages and structural variations where gate loading or pressure on the connector will occur.

It is not enough just to require a locking type snap hook. Connectors that have significantly stronger gates are readily available and have been for many years to the point where ANSI has made it a requirement for construction and design of connectors. Connectors tested and approved to the ANSI Z359.12 standard provide workers with an additional level of security that would help prevent fatalities (Ex. 127).

OSHA does not agree with, and national consensus standards do not support, ASSE’s argument. The Z359.12–2012 and A10.32–2012 standards include component

compatibility requirements. In addition, the final rule addresses the conditions that ASSE identifies as making the elimination of incompatible connections infeasible. For example, like the ANSI/ASSE standards, the final rule requires that anchorages, connectors, and other components be capable of supporting 5,000 pounds (§ 1910.140(c)(4), (c)(7), and (c)(13)(i)). In addition, final § 1910.27(b)(1) requires that anchorages be certified as meeting the 5,000-pound requirement. The final rule also incorporates a number of other provisions in Z359.12–2012 to ensure workers have “an additional level of security that would help prevent fatalities.”

ASSE also maintains that the requirement in proposed (c)(19) is not feasible because “we continue to see fatalities related to incompatible connections and gate failure” after OSHA included a connector compatibility requirement in § 1910.66, appendix C, and the construction fall protection standard (29 CFR part 1926, subpart M) (Ex. 127). OSHA does not agree with ASSE’s conclusion. The fact that accidents, fatalities, injuries, or illnesses may occur after OSHA implements a standard does not mean that the controls the standard requires are not feasible. Rather, it is more likely that those incidents are the result of noncompliance with the connector compatibility requirements in § 1910.66 and the construction fall protection. Accordingly, the final rule adopts the proposed requirement that employers must ensure ropes, belts, lanyards, and harnesses used for personal fall protection are compatible with all connectors used, regardless of whether the components are integral elements of the personal fall protection system, individual components, or replacements produced by the same or different manufacturers.

Paragraph (c)(20) of the final rule, like the proposal, requires that employers ensure all ropes, lanyards, lifelines, harnesses, and belts used for personal fall protection systems are protected from being cut, abraded, melted, or otherwise damaged. OSHA believes that these components of personal fall protection systems need to be protected from the specified hazards, which could cause damage and deterioration that results in components losing strength and failing.

Final paragraph (c)(20) is broader than the requirements in OSHA’s shipyard employment and construction fall protection standards (§§ 1915.159(c)(4), 1926.502(d)(11)), which only address protecting lanyards and lifelines from damage. By contrast, Appendix C of the

Powered Platforms standard specifies that any component of a personal fall arrest system with any significant defect which might affect its efficiency must be withdrawn from service immediately, or destroyed (§ 1910.66, appendix C, Section III(f)). The Z359.1–2007 and A10.32–2012 standards contain several provisions requiring lifelines, lanyards, ropes, webbing, and other fall protection system components to be protected from the types of damage the final rule specifies.

In addition to protecting fall protection equipment components from cuts, abrasions, and melting, the final rule requires that employers protect fall protection equipment from other damage (*i.e.*, “otherwise damaged”). Although the final rule does not define “otherwise damaged,” OSHA’s other fall protection standards and the national consensus standards provide useful guidance about the types of damage that employers need to consider. For example, the shipyard employment standard requires equipment be protected from “cuts, abrasions, burns from hot work operations and deterioration from acids, solvents, and other chemicals” (§ 1915.159(c)(4)). Appendix C to the Powered Platforms standard lists a number of hazards: “Any components with any significant defect, such as cuts, tears, abrasions, mold, or undue stretching; . . . damage due to deterioration; contact with fire, acids, or other corrosives; . . . wearing or internal deterioration of ropes alterations” (§ 1910.66, appendix C, Section III(f)).

The A10.32–2012 standard requires that employers protect fall protection equipment from abrasion, cutting, welding, electrical, and chemical hazards (Section 7.5). Similarly, Z359.1 requires that fall protection equipment be made of “abrasive and heat resistant materials” (Sections 3 and 5). OSHA did not receive any comments on the proposed provision, and adopts paragraph (c)(20) with the minor revisions mentioned above. In addition, appendix C to § 1910.140 includes many hazards employers should consider when inspecting personal fall protection systems (appendix C to § 1910.140, Section (g)).

Paragraph (c)(21) of the final rule, like the proposed rule, requires that employers provide for the prompt rescue of workers in the event of a fall. This requirement is necessary because workers suspended after a fall are in danger of serious injury due primarily to suspension trauma.

The final rule is consistent with the rescue requirements in OSHA’s Powered Platforms, shipyard

employment, and construction fall protection standards (§§ 1910.66, appendix C, Section I(e)(8); 1915.159(c)(7); 1926.503(d)(20)). Those standards require that employers “provide for prompt rescue of employees in the event of a fall or shall assure the self-rescue capability of employees” (Powered Platforms (§ 1910.66, appendix C, Section I(e)(8))).

The final rule also is drawn from three national consensus standards. The A10.32–2012 standard specifies that employers develop a “project-specific” rescue plan that provides an appropriate form of employee rescue (Section 7.2.2.). The standard also requires that the rescue plan include providing adequate rescue equipment and training workers in self-rescue or alternate means. The Z359.4–2007 standard provides useful information to assist employers in planning for rescues in the event of a fall. Finally, Z359.1–2007 requires that worker training address fall rescue (Section 7.3.2).

Paragraph (c)(21) of the final rule sets forth two fundamental points: (1) Employers must provide for the rescue of workers when a fall occurs, and (2) the rescue must be prompt. With regard to the first point, the final rule requires that employers must “provide” for rescue, which means they need to develop and put in place a plan or procedures for effective rescue. The plan needs to include making rescue resources available (*i.e.*, rescue equipment, personnel) and ensuring that workers understand the plan.

Appendix C to § 1910.140 provides guidance to employers on developing a rescue plan (appendix C to § 1910.140, Section (h)) as does Z359.4–2007. For example, appendix C recommends that employers evaluate the availability of rescue personnel, ladders, and other rescue equipment, such as mechanical devices with descent capability that allow for self-rescue and devices that allow suspended workers to maintain circulation in their legs while they are awaiting rescue. OSHA’s Safety and Health Bulletin on Suspension Trauma/Orthostatic Intolerance identifies factors that employers should consider in developing and implementing a rescue plan, including recognizing the signs and symptoms of suspension trauma and factors that can increase the risk of trauma, rescuing unconscious workers, monitoring suspended and rescued workers, providing first aid for workers showing signs and symptoms of orthostatic intolerance (see SHIB 03–24–

2004, updated 2011).⁷⁷ ISEA supported requiring employers to have a rescue plan and make available equipment and personnel to provide for prompt rescue after a fall (Ex. 185).

OSHA notes that although an increasing number of employers provide devices that allow workers to rescue themselves, where self-rescue is not possible, the employer must ensure that appropriate rescue personnel and equipment is available for prompt rescue. For example, unconscious workers will not be able to move so they cannot pump their legs to maintain circulation or relieve pressure on their leg muscles. Workers who are seriously injured or in shock also may have difficulty effecting self-rescue.

On the second point, the final rule requires that employers provide “prompt” rescue of workers who are suspended after a fall. A number of commenters asked OSHA to clarify the meaning of “prompt” rescue, for example, asking whether it means “immediately” or “quickly” (Exs. 145; 185; 198). ISEA and CSG urged OSHA to require that suspended workers be rescued “quickly,” pointing out the life-threatening dangers of suspension trauma and orthostatic intolerance (Exs. 185; 198). In 2000, OSHA adopted the language ISEA and CSG recommends in answering the question of prompt rescue as it applies to the construction fall protection standard: “[T]he word “prompt” requires that rescue be performed quickly—in time to prevent serious injury to the worker” (Letter to Mr. Charles E. Hill, August 14, 2000).⁷⁸

OSHA’s definition of “prompt” is performance based. Employers must act quickly enough to ensure that the rescue is effective; that is, to ensure that the worker is not seriously injured. If the worker is injured in the fall, the employer must act quickly enough to mitigate the severity of the injury and increase the survivability of the worker. OSHA’s performance-based definition recognizes, and takes into account, the life-threatening dangers of prolonged suspension:

Orthostatic intolerance may be experienced by workers using fall arrest systems. Following a fall, a worker may remain suspended in a harness. The sustained immobility may lead to a state of unconsciousness. Depending on the length of time the suspended worker is unconscious/immobile and the level of venous pooling, the resulting orthostatic intolerance may lead to death. . . . Unless the worker is rescued

promptly using established safe procedures, venous pooling and orthostatic intolerance could result in serious or fatal injury, as the brain, kidneys, and other organs are deprived of oxygen.

Prolonged suspension from fall arrest systems can cause orthostatic intolerance, which, in turn, can result in serious physical injury, or potentially, death. Research indicates that suspension in a fall arrest device can result in unconsciousness, followed by death, in less than 30 minutes (SHIB 03–24–2004).

Because of the potential for severe and even fatal injuries from prolonged suspension, OSHA believes that employers can ensure their rescue operations are effective if they model them on their first-aid plans. To illustrate, in the final rule revising general workplace conditions in shipyard employment (29 CFR part 1915, subpart F), which requires that employers provide “readily accessible” first aid, OSHA defined “readily accessible” as “capable of being reached quickly enough to ensure that medical service interventions are effective,” and noted that “medical services and first aid must be provided in a timeframe that will ensure their effectiveness in treating an injured or ill employee. Medical services that can be delivered quickly enough to the employee to be effective would be considered readily accessible” (76 FR 24576, 24600 (5/2/2011)). (For a detailed discussion of effective emergency aid and first aid, see the preamble of the shipyard employment standard (76 FR 24599–664)).

OSHA also finds that the emergency-aid and first-aid response needs to be available within a few minutes “in workplaces where serious accidents such as those involving falls . . . are possible” (Letter to Mr. Charles Brogan, January 16, 2007).⁷⁹ As ISEA pointed out, the Z359.4–2007 standard recommends that contact be made within six minutes of a fall.

In summary, prompt rescue means employers must be able to rescue suspended workers quickly enough to ensure the rescue is successful—quickly enough to ensure that the worker does not suffer physical injury, such as injury or unconsciousness from orthostatic intolerance, or death. Many employers provide self-rescue equipment so workers can rescue themselves quickly after a fall, ensuring that the rescue is prompt and risks associated with prolonged suspension are minimized. OSHA believes the performance-based

approach in the final rule ensures prompt rescue of workers after a fall, while also giving employers flexibility to determine how best to provide prompt and effective rescue in the particular circumstance.

OSHA also received several comments on what the final rule requires to protect workers from orthostatic intolerance. ITA requested that OSHA clarify whether the final rule requires workers to carry self-rescue equipment (Ex. 145). ISEA and CSG recommended that OSHA require employers to equip workers with suspension-relief devices and revise the definition of “personal fall arrest system” to include those devices. They said there are widely available devices that permit a suspended worker to relieve pressure from the harness and to “maintain circulation in the large muscles of legs, reducing the potential for suspension trauma until help arrives” (Exs. 185; 198). According to ISEA and CSG, the devices are lightweight, portable, and low cost, and workers can carry them as part of the personal fall arrest system. OSHA agrees that the benefits these devices offer are promising, and recommends that employers provide them, particularly in those situations where self-rescue may not be possible.

Paragraph (c)(22) of the final rule requires that workers wear personal fall protection systems with the attachment point of the body harness in the center of the worker’s back near shoulder level. The final rule includes one exception—the attachment point may be located in the pre-sternal position if the free fall distance is limited to 2 feet or less.

The final rule differs from OSHA’s Powered Platforms, construction, and shipyard employment fall protection standards, which do not permit the attachment point to be located in the pre-sternal position (§§ 1910.66, appendix C, Section I(e)(4); 1915.159(c)(1)(i); 1926.502(d)(17)). OSHA drew the exception for pre-sternal positioning in final paragraph (c)(22) from Z359.1–2007, which permits a front-mounted attachment point when the maximum free fall distance is two feet and the maximum arrest force is 900 pounds (Section 3.2.2.5a). A note to that section explains: “The frontal attachment element is intended for the use in rescue, work position, rope access, and other ANSI/ASSE Z359.1 recognized applications where the design of the systems is such that only a limited free fall of two feet is permitted” (Section E3.2.2.5a). The I–14.1–2001 standard incorporates this requirement from Z359.1 (Section 9.2).

⁷⁷ Available from OSHA’s Web site at: <https://www.osha.gov/dts/shib/shib032404.html>.

⁷⁸ Available from OSHA’s Web site at: http://www.osha.gov/pls/oshaweb/owadisp.show_document?p_table=INTERPRETATIONS&p_id=24110.

⁷⁹ Available from OSHA’s Web site at: http://www.osha.gov/pls/oshaweb/owadisp.show_document?p_table=INTERPRETATIONS&p_id=25627.

The final rule differs from the proposed rule in two respects. First, the language “or above the employee’s head” has been eliminated from the first sentence of the proposed provision because OSHA believes this language is inaccurate. A properly sized and adjusted harness should not allow the attachment point to be above the wearer’s head. Second, the proposal would have required that front-mounted attachment points be limited to situations where the maximum fall arrest force does not exceed 900 pounds. OSHA deleted this requirement in this final rule because the Agency does not believe that the requirement is necessary. Final paragraph (c)(22) permits pre-sternal attachment only when the maximum free fall limit is two feet. OSHA believes this limit is sufficient to ensure fall arrest forces are reduced significantly in the event of a fall. ISEA (Ex. 185) and CSG (Ex. 198) opposed the 900-pound fall arrest requirement, which they said was “too prescriptive and restrictive.”

Several commenters supported allowing a front-mounted attachment in certain situations, and OSHA did not receive any comments opposing its use. ISEA (Ex. 185) and CSG (Ex. 198) supported allowing front-mounted attachment points because it allowed workers to “conduct a variety of tasks, such as rotating and leaning.” AWEA also supported pre-sternal connection points, noting, “Rope access workers around the world have been employing this technique for decades with excellent results” (Ex. 329 (1/21/2011, p. 22)).

OSHA believes that allowing pre-sternal attachment when the free fall distance is limited to two feet will have only a minimal effect on the distribution of fall arrest forces, thereby reducing the risk of serious neck and back injury. Such use will make self-rescue easier in specific situations, such as confined spaces, window cleaning, and climbing activities because it is easier to work in front of the body than work behind one’s body. In addition, permitting a front-mounted attachment point provides greater flexibility for employers in certain activities, such as climbing or using rope descent systems for window washing. Accordingly, the final rule retains the proposed exception for front-mounted attachment points when the maximum free fall distance is two feet.

Paragraph (d)—Personal Fall Arrest Systems

Paragraph (d) of the final rule establishes specific requirements for using personal fall arrest systems. A

personal fall arrest system is one type of personal fall protection system. The final rule defines a personal fall arrest system as a system used to arrest a worker in a fall from a walking-working surface. A personal fall arrest system consists of a body harness, anchorage, and a connector. The means of connection may include a lanyard, deceleration device, lifeline, or a suitable combination of these. OSHA notes that the provisions in paragraph (d) apply in addition to those provisions in paragraph (c), which apply to all types of personal fall protection systems.

Paragraph (d) of the final rule includes some changes in the regulatory text from the proposal that clarify and simplify the language. Those changes do not affect the meaning or purpose of the provisions in paragraph (d). OSHA believes that the changes make the requirements in paragraph (d) easier for employers to understand, which should increase worker safety, and compliance with the final rule. Paragraph (d) consists of two primary components: Paragraph (d)(1) establishes performance criteria for personal fall arrest systems, while paragraph (d)(2) addresses the use of personal fall arrest systems. OSHA based the requirements for personal fall arrest systems on OSHA’s Powered Platforms, construction, and shipyard employment fall protection standards (§§ 1910.66, appendix C; 1915.159; 1926.502(d)), as well as on several national consensus standards, including Z359.1–2007, A10.32–2012, and I–14.1–2001.

System performance criteria. The requirements in final paragraph (d)(1), with one exception, are almost identical to the requirements in OSHA’s Powered Platforms, shipyard employment, and construction fall protection standards (§§ 1910.66, appendix C, Section I(d)(1); 1915.159(b)(6); 1926.502(d)(16)).⁸⁰

Paragraph (d)(1)(i) of the final rule requires that employers ensure personal fall arrest systems limit the maximum fall arrest forces on a worker to 1,800 pounds. OSHA discussed the requirement extensively in the preamble to the Powered Platforms final rule, noting that the Agency proposed “a

⁸⁰ OSHA first promulgated these performance requirements in the Powered Platforms rulemaking (54 FR 31407 (7/28/1989)). In the preamble to that final rule, OSHA said that it intended to apply a future rule to all uses of personal fall arrest systems in general industry, including powered platforms, and that Appendix C to that rule would be superseded by the new rule (54 FR 31445–46). This final rule, like the proposal (75 FR 29146), removes appendix C to OSHA’s Powered Platform rule (§ 1910.66). Final § 1910.140 addresses personal fall arrest systems used in all general industry, including powered platforms.

force limit of 10 times the worker’s weight or 1,800 pounds (8 kN) whichever is less” (54 FR 31450). OSHA explained that the Powered Platforms proposed rule was consistent with ANSI A10.14–1975 and a report by the National Bureau of Standards (now the National Institute for Science and Technology) (54 FR 31450). In addition, OSHA said comments from the United States Technical Advisory Group, an advisory group representing both government and private interests, also supported the 1,800-pound maximum fall arrest limit for personal fall arrest systems.

When the Z359.1 standard was first published in 1992, it also incorporated the 1,800-pound maximum fall arrest force for personal fall arrest systems used with body harnesses, and retained the requirement in every update since 1992. The updated versions of Z359.1 (1992, 2002, and 2007) each explained the basis for the 1,800-pound maximum arresting force (MAF) limit as follows:

The 1,800 pound (8 kN) MAF criteria included in this standard is based on the following considerations. In the mid-1970’s medical information developed in France confirmed earlier United States research which observed that approximately 2,700 pounds (12 kN) is the threshold of significant injury incidence for physically fit individuals subjected to drop impacts when wearing harnesses. The French arbitrarily halved the above force and established 1,350 pounds (6 kN) as their national standard for MAF in PFAS. Canada’s Ontario Ministry of Labor reviewed this information and elected to establish 1,800 pounds (8 kN) for MAF. This MAF has been in effect since 1979 in the Ontario Provincial standard. Since that time there have been no reported deaths or serious injuries associated with the arresting of accidental falls of individuals. In addition, ISO/TC94/SC4, in working drafts, has established the 1,800 pounds (8 kN) limit on MAF. On the basis of this information, 1,800 pounds (8 kN) is considered the appropriate MAF for inclusion in this standard where harnesses are to be used in arresting falls (Section E3.1.2).

Based on this research, OSHA believes that the 1,800 pound fall arrest force will adequately protect workers. OSHA did not receive any comments opposing the proposed provision, and is adopting it in the final rule with only minor editorial changes.

Paragraph (d)(1)(ii) limits the maximum deceleration distance to 3.5 feet. This requirement pertains only to the operation of the deceleration device itself and not to the 6-foot free fall distance specified in paragraph (d)(2)(ii). The 3.5-foot deceleration distance in this paragraph is in addition to the 6-foot free fall distance. Accordingly, once the free fall ends and the deceleration device begins to

operate, the personal fall arrest system must bring the worker to a complete stop within 3.5 feet. Combining the free fall distance with the deceleration distance means that the total maximum distance a worker may travel during a fall could be 9.5 feet.

The final rule is the same as the requirement in the Powered Platforms, construction, and shipyard employment fall protection standards (§§ 1910.66, appendix C, Section I (d)(1)(iii); 1915.159(b)(6)(iii); 1926.502(d)(16)(iv); also see 54 FR 31450 and 59 FR 40708). Paragraph (d)(1)(ii) also is consistent with Z359.1–2007 (Section 3.1.2). In addition, the 3.5 deceleration distance has been an industry and manufacturer standard for years. OSHA did not receive any comments on the proposed requirement, and the final rule is adopting it as proposed with only minor changes.

Paragraph (d)(1)(iii) requires personal fall arrest systems to have sufficient strength to withstand twice the potential impact energy of the worker free falling a distance of 6 feet, or the free fall distance permitted by the system. In the final rule, OSHA has clarified the provision by removing the proposed language “whichever is less.” Both ways of meeting the standard are acceptable and the removed language is unnecessary. OSHA notes that the alternative free fall distance is the one the manufacturer lists in the instructions or specifications for the specific personal fall arrest system.

Compliance with this requirement ensures that the personal fall arrest system will not fail even if subjected to twice the design shock load. For example, a personal fall arrest system harness that just meets the maximum permitted arresting force allowed in final paragraph (d)(1)(i) must be able to withstand an impact force of 3,600 pounds, which is twice the 1,800-pound potential arresting force of a worker using the system falling up to 6 feet. The Agency determined that a safety factor of two is necessary to ensure that the personal fall arrest system will not fail even if there is unavoidable wear on the system as a result of normal use. In practice, fall arrest forces should never approach the design shock load because the free fall distance likely will be 6 feet or less, and because lifelines which absorb energy, often will be used. OSHA also determined that a safety factor of two provides adequate protection and makes the final rule consistent with the approach in OSHA’s Powered Platforms, construction, and shipyard employment fall protection standards.

Paragraph (d)(1)(iv) is a new paragraph added to the final rule

requiring that fall arrest systems be capable of sustaining the worker within the system or strap configuration without making contact with the worker’s neck and chin area. The National Institute for Occupational Safety and Health (NIOSH) recommended adding this provision, saying: “[S]udies have shown that during suspended condition, the chest strap and ring of the harness can ride up on the worker’s neck if the harness does not fit properly, posing a risk of injury to the worker [Hsiao et al., 2007; Hsiao et al., 2009]” (Ex. 164).

NIOSH also noted that “individuals with soft hip and thigh musculature are at increased risk of chest and neck strap interference to the neck and chin area when suspended after a successful arrest of fall” (Ex. 164). OSHA agrees with NIOSH that a specific requirement is needed to ensure workers are not injured while using a personal fall arrest system. If employers select personal fall arrest systems that do not fit workers properly or fail to train workers in how to use systems properly, the system may not keep the worker safe within the strap configuration or body harness if a fall occurs, or may injure the worker’s neck and chin area.

OSHA does not believe that adding the requirement imposes any new burden on employers, but rather reinforces other requirements with which the employer must comply. Specifically, the general requirements that apply to all PPE, including personal fall arrest systems, require that employers “[s]elect PPE that properly fits each affected employee” (29 CFR 1910.132(d)(1)(iii)). If the personal fall arrest system does not fit properly, the worker may not be protected adequately if a fall occurs. OSHA also notes that applicable training requirements in its PPE standard require employers to train workers in “[h]ow to properly don, doff, adjust, and wear PPE” (29 CFR 1910.132(f)(1)(iii)).

Final paragraph (d)(1)(v), proposed as a note to paragraph (d)(1), makes clear that personal fall arrest systems meeting the criteria and protocols set out in appendix D to § 1910.140 will be deemed to be in compliance with the requirements of paragraphs (d)(1)(i) through (iii) when used by a worker who has a combined tool and body weight of less than 310 pounds. Appendix D provides one method that will allow employers to evaluate the ability of the personal fall arrest system to meet the necessary criteria. However, appendix D is restricted to situations in which the total body and tool weight is less than 310 pounds because the test methods were designed for that weight.

If a personal fall arrest system needs to support a greater weight, the test methods in appendix D may still be used, provided the employer modifies them to account for the additional weight, such as by using a heavier or lighter test weight to reflect the heavier or lighter weight of the worker. Ellis supported using the 310-pound weight in final paragraph (d) and in the test methods specified by appendix D to § 1910.140 (Ex. 155).

System use criteria. Final paragraph (d)(2) establishes criteria for the use of personal fall arrest systems. In paragraph (d)(2)(i), OSHA requires that, for horizontal lifelines that may become vertical lifelines, the device used to connect to the horizontal lifeline must be capable of locking in both directions on the lifeline. OSHA believes this requirement is necessary because a horizontal lifeline could become a vertical lifeline if the support lines on one end of a suspended scaffold or similar work platform fail. In this case, if the rope grab does not lock in both directions on the now vertical lifeline, it could fail to hold, allowing the worker to fall. OSHA drew this requirement from the Powered Platforms standard (§ 1910.66, appendix C, Section I(e)(2)) and the construction standard (§ 1926.502(d)(7)). OSHA did not receive any comments on the proposed provision and is adopting it without substantive change.

Paragraph (d)(2)(ii) requires the personal fall arrest system to be rigged so that a worker cannot free fall more than 6 feet, nor contact a lower level.⁸¹ The system strength and deceleration criteria for personal fall arrest systems are based on a maximum free fall distance of 6 feet. OSHA based this provision on the Powered Platforms, construction, and shipyard employment fall protection standards (§§ 1910.66, appendix C, Section I(e)(3);

⁸¹ In subpart M, Interpretations and Clarifications—Fall Protection, OSHA stated that if the employer has documentation to demonstrate that these maximum arresting forces are not exceeded and that the personal fall arrest system will operate properly, OSHA will not issue a citation for violation of the free fall distance.

U.S. manufacturers of fall protection equipment test their equipment in accordance with test procedures prescribed in ANSI standards (ANSI A10.32 and ANSI Z359) which calls for equipment to be tested based on a 6-foot free fall distance. Unless the equipment has been tested for a free fall greater than 6 feet, the results are unknown. Therefore, if an employer must exceed the free fall distance, the employer must be able to document, based on test data, that the forces on the body will not exceed the limits established by the standard, and that the personal fall arrest system will function properly.

See interpretation M–3 on OSHA’s Web site: http://www.osha.gov/Publications/Const_Res_Man/1926m_interps.html.

1915.159(b)(6)(i); 1926.502(d)(16)(iii)). The final rule also is similar to Z359.1–2007 (Section 7.2) and A10.32–2012 (Section 5.2.1).

In the final rule, OSHA added an exception that permits a free fall to be more than 6 feet provided the employer can demonstrate the manufacturer designed the system to allow a free fall of more than 6 feet and tested the system to ensure a maximum arresting force of 1,800 pounds is not exceeded. If the system is not designed for such a purpose, allowing a longer free fall distance could mean the strength and deceleration criteria are not adequate to protect the worker. This added language is consistent with OSHA's interpretation of 29 CFR part 1926, subpart M.⁸² OSHA did not receive any comments on the proposed provision and is adopting it as discussed.

Body belts. Paragraph (d)(3) of the final rule prohibits employers from using body belts as part of a personal fall arrest systems. The final provision is consistent with A10.32–2012 (Section 1.4.1). OSHA notes that both the construction industry and shipyard employment standards already prohibit the use of body belts as part of personal fall arrest systems (§§ 1915.159; 1926.502(d)). Since 1998, those fall protection standards have prohibited the use of body belts in personal fall arrest systems because, as discussed in the final rule to § 1926.502, workers wearing them have been seriously injured by the impact loads transmitted and by the pressures imposed while suspended after fall arrest. OSHA does not believe that employers will have any difficulty complying with this provision because virtually all personal fall arrest systems manufactured and in use in the United States are equipped with body harnesses, not body belts. ISEA, the only commenter on this provision, supported the ban (Ex. 185) and the Agency adopts the provision as proposed.

Paragraph (e)—Positioning Systems

Paragraph (e) establishes specific requirements for positioning systems, including window cleaner's positioning systems. These requirements apply in addition to the general requirements in paragraph (c), which apply to all types of personal fall protection systems. Positioning systems, which sometimes are called "work-positioning systems," are a type of personal fall protection system. The final rule defines positioning system as a system of

equipment and connectors that, when used with its body harness or body belt, allow a worker to be supported on an elevated vertical surface (e.g., wall, window sill, utility pole) and work with both hands free.

OSHA received several general comments on the proposed requirements for positioning systems. For example, Ellis recommended that workers who use positioning systems should have additional fall protection (Ex. 155). OSHA notes that workers using positioning systems are attached to two separate anchor points. If one anchor were to fail, the worker would still be protected from falling by the attachment to the other anchor.

Weatherguard said, "If OSHA does not want to promulgate the preciseness that is required to accomplish this, a reference to the I–14 Standard would direct readers to what they need to have for compliance" (Ex. 168). Regarding Weatherguard's recommendation, OSHA notes that the Agency drew a number of requirements from I–14.1–2001, and this preamble explains those provisions so employers know what action is necessary to comply with the final rule.

The Tree Care Industry Association (TCIA) expressed concern that workers in their industry would not be allowed to use positioning systems as these systems were defined in the proposed rule (Ex. 174). OSHA notes that the TCIA is commenting on the proposed revision to § 1910.67(c)(2)(v), which permits workers to use positioning systems or personal fall arrest systems when working in aerial lifts. TCIA said:

Line clearance tree trimmers and other arborists often work in aerial lifts that are elevated to work positions directly above high voltage wires, trees, buildings and other structures to trim trees. Notably, this work position is not typical for a lineman either building or maintaining some part of an electrical system. There is a unique and unavoidable job hazard intrinsic in the typical work position of the line clearance tree trimmer that is inadequately addressed by OSHA's current fall protection proposal. To best address this hazard and obtain the greatest protection of affected workers and also to allow for the self-rescue of an aerial lift operator who has fallen, OSHA should allow the use of a body belt and two- to three-foot lanyard. This PPE combination provides for the shortest overall fall distance, and thus provides the greatest protection against fatally dropping into nearby electric wires and secondarily, any other potentially injurious object at a lower level. The short lanyard minimizes free fall, thereby reducing the arresting force in the system. Finally, the attachment at the operator's waist allows for the possibility of self-rescue.

A narrow requirement governing all situations, such as the one OSHA has

proposed, does not promote worker safety to the extent that it could or should. It is important for OSHA to preserve the performance-based nature of subpart I requirements and allow the employer to assess the hazards and choose the fall protection that in its estimation will provide the greatest measure of safety in a given situation. The hazard we have illustrated could be addressed with a simple note under 1910.67(c)(2)(v): "NOTE: If the employer can demonstrate that a greater hazard to the aerial lift operator is created by contact with structures or electrical conductors below the elevated lift, then a body belt and lanyard of up to three feet in length may be employed for fall protection" (Ex. 174).

Positioning systems, as defined in § 1910.140(b), cannot be used in aerial lifts because the workers are not on a vertical surface such as a wall, but rather on the horizontal surface of the aerial lift bucket. Therefore, OSHA is revising the requirement in § 1910.67(c)(2)(v) to allow workers to use either travel restraint or personal fall arrest systems.

OSHA also addressed the issue of fall protection systems for workers performing construction activities in aerial lifts in a memorandum dated August 22, 2011.⁸³ That memorandum established the same policy regarding fall protection for construction workers in aerial lifts as the requirement specified by this final rule for general industry workers in aerial lifts. The applicable portion of that memorandum states:

As has been the Agency's longstanding policy, an employer may comply with OSHA's fall protection requirements for aerial lifts in one of three ways:

1. Use of a body belt with a tether anchored to the boom or basket (fall restraint system),
2. Use of a body harness with a tether (fall restraint system), or
3. Use of a body harness with a lanyard (fall arrest system).

Ellis said that OSHA's policy provided a more complete answer to the issue of fall protection for workers in aerial lifts, and recommended that OSHA add the language to the final rule (Ex. 155). OSHA does not believe such a revision is necessary because the final rule already makes clear that personal fall arrest systems can only be used with a body harness and that travel restraint systems may use a body harness or body belt.

System performance requirements. Final paragraph (e)(1) establishes performance criteria for positioning systems. Paragraph (e)(1)(i), like the proposed rule, requires employers to

⁸² See interpretation M–3 on OSHA's Web site: http://www.osha.gov/Publications/Const_Res_Man/1926m_interps.html.

⁸³ Available from OSHA's Web site at: http://www.osha.gov/pls/oshaweb/owadisp.show_document?p_table=INTERPRETATIONS&p_id=27731.

ensure that positioning systems, except window cleaner's positioning systems, are capable of withstanding, without failure, a drop test consisting of a 250-pound weight dropped 4 feet. Although the Z359.3–2007 standard requires a 4-foot drop test with a 300-pound weight, OSHA is maintaining the 250-pound weight in order to make the final rule consistent with OSHA's construction industry rule. Many employers use the same personal fall arrest system for performing both general industry and construction activities. If OSHA were to adopt the weight that Z359.3–2007 incorporates, employers may not be able to use the same equipment for both types of activities. OSHA believes this could lead to confusion and non-compliance. OSHA did not receive any comments on the proposed provision and finalizes the provision as proposed.

Paragraph (e)(1)(ii)(A) of the final rule, like the proposed rule, requires employers to ensure that window cleaners' positioning systems are capable of withstanding, without failure, a drop-test consisting of a 6-foot drop of a 250-pound weight. Paragraph (e)(1)(ii)(B) requires that these systems limit the initial fall arresting force on the falling worker to not more than 2,000 pounds, with a duration not exceeding 2 milliseconds, and any subsequent fall arrest forces do not to exceed 1,000 pounds. Window cleaners' positioning systems have a potential for greater free fall distances. As such, the final rule requires a more rigorous drop test for these systems than for other positioning devices. The rigorous drop test for window cleaners' positioning systems, combined with the limit on initial arresting forces ensures workers will not be injured if a free fall occurs. The final rule uses the same approach for positioning systems as the shipyard employment standard (29 CFR 1915.160(b)(2)).

Final paragraph (e)(1)(iii), proposed as a note, is applicable to paragraphs (e)(1)(i) and (ii) and explains that positioning systems, including window cleaners' positioning systems, meeting the tests methods and procedures outlined in appendix D to § 1910.140 are considered to be in compliance with these provisions. The proposed rule included two notes and, for simplicity, the final rule combined these notes into one provision in the actual regulatory text.

Weatherguard recommended that OSHA reference the I–14.1–2001 standard in the final rule (Ex. 168). The final rule uses provisions from that standard both as a basis for a number of requirements and in the reference section as a resource for further

information. There were no other comments and the provisions are finalized as discussed.

Paragraph (e)(1)(iv) addresses criteria applicable to lineman's body belt and pole strap systems. Although positioning equipment used in electric power transmission and distribution work is not to be used as insulation from live parts, when a worker is working near live parts, it is possible that the lineman's body belt and pole strap systems may come into contact with them. As such, it is important that these systems provide some level of insulation.

Paragraphs (e)(1)(iv)(A) through (C) require employers to ensure that a lineman's body belt and pole strap system be capable of passing dielectric and leakage current tests, as well as a flammability test. The requirements in paragraphs (e)(1)(iv)(A) and (B), like the proposed rule, are consistent with those in §§ 1910.269(g)(2)(iii)(G) and 1926.954(b)(2)(vii). OSHA notes that the voltages listed in these paragraphs are alternating currents. OSHA included these tests in the final rule because the Agency believes that requiring positioning straps to be capable of passing the electrical tests in final paragraphs (e)(1)(iv)(A) and (B) will provide an additional measure of protection to workers, for example, if a conductor or other energized part slips and lands on the strap or if the strap slips from the worker's hand and lands on an energized part. The requirements of final paragraphs (e)(1)(iv)(A) and (B) are the same as those in revised § 1910.269 (79 FR 20316 (4/11/2014)). Additionally, the tests in the final rule are equivalent to the ones ASTM F887–12e1 (Section 15.3.1 and Note 2) requires.

Paragraph (e)(1)(iv)(C) is a new paragraph that OSHA added to the final rule requiring that lineman's body belt and pole strap systems meet the flammability test in Table I–7. This test is equivalent to the one in 29 CFR 1926, subpart V. The flammability test in Table I–7 specifies the step-by-step process employers must ensure is followed when lineman's body belt and pole strap systems are tested. The table also includes the specific criteria the strap must meet to pass the flammability test.

OSHA added the flammability test to the final rule because employees working near energized parts must be provided with the same level of protection regardless of whether they are performing general industry or construction activities. OSHA believes lineman's body belt and pole strap systems already meet these

requirements, so the final rule will not impose additional costs and burdens on employers.

The proposal contained notes indicating that positioning straps which passed direct current tests at equivalent voltages would be considered to be in compliance with paragraphs (e)(1)(iii)(A) and (B). Because these notes were more in the nature of guidance, OSHA did not carry them forward in the final regulatory text. Nonetheless, this is still a way that employers may demonstrate compliance with the requirements of paragraphs (e)(1)(iii)(A) and (B) of the final rule.

System use criteria for window cleaners' positioning systems. The requirements in paragraph (e)(2) of the final rule, like the proposed rule, contain criteria applicable only to window cleaners' positioning systems and components (*i.e.*, window cleaners' belts and window cleaners' belt anchors). There are no specific requirements for this type of personal fall protection system in existing OSHA standards. Currently, OSHA enforces the general requirement to have fall protection under § 1910.132 (Personal Protective Equipment) as well as under section 5(a)(1) ("general duty clause") of the OSH Act (29 U.S.C. 654) while performing window cleaning operations and relies on national consensus standards for criteria that such systems need to meet. OSHA believes that including requirements specific to window cleaners' positioning systems in this final rule will enhance compliance by clarifying exactly what requirements apply to these systems.

OSHA drew the requirements in paragraph (e)(2) from the I–14.1–2001 standard that addresses the design, strength, and installation of window cleaners' positioning systems. OSHA believes that these criteria, in conjunction with the general requirements in paragraph (c) that are applicable to all personal fall protection systems, provide a reasonable and necessary level of safety for workers using these systems. OSHA believes that window cleaners' positioning systems and their associated anchors are not used as commonly as they once were. However, since these systems are still used on some buildings, OSHA finds that these minimum requirements are still necessary to ensure workers are protected during window cleaning operations.

Final paragraph (e)(2)(i)(A) requires the employer to ensure that window cleaners' belts are designed and constructed so belt terminals will not pass through the fastenings on the body belt or harness if a terminal comes loose

from the window anchor. OSHA believes this requirement is necessary because, if the belt terminal comes loose from the window anchor, the worker will likely fall if the belt is not designed to keep the belt terminals from pulling through the fastenings on the waist belt. There were no comments on the proposed provision and it is finalized with only minor revisions for clarity.

Final paragraph (e)(2)(i)(B), like the proposed rule, requires the employer to ensure that window cleaners' belts be designed and constructed so the length of the runner from the tip of one terminal end to the tip on the other end does not exceed eight feet. This requirement is consistent with I-14.1-2001 (Section 10.2.9(c)) and OSHA believes it is necessary to limit the length of runners to 8 feet so that workers are not leaning too far back from the window they are cleaning. Leaning too far back may cause the worker to lose balance and become inverted, possibly striking the building and becoming injured. There were no comments on the proposed provision and it is finalized without revision.

Final paragraph (e)(2)(ii) requires the employer to ensure that window anchors used for attaching window cleaners' belts are installed in the side of window frames or mullions at a height not less than 42 inches and not more than 51 inches above the window sill. This requirement is consistent with I-14.1-2001 (Section 10.2.5) and OSHA believes it is widely accepted within the industry. Prior to the I-14.1 standard, the provision was also present in the ANSI/ASME A39.1 standard, which dates back to 1933. There were no comments on the proposed provision and it is finalized with only minor revisions for clarity.

Final paragraph (e)(2)(iii) requires that employers ensure window anchors are capable of supporting a minimum load of 6,000 pounds. It is consistent with I-14.1-2001 (Section 10.2.4). The final provision is similar to the proposal but it does not include the proposed requirement that the structures to which window anchors are attached also must support a 6,000-pound minimum load requirement.

Weatherguard opposed the proposed requirement, saying:

[This requirement was] not consistent with the current codes and standards. The requirement that has been in place for at least the last 60 years is that the anchor be capable of supporting a 6,000-pound load without fracture in the direction that it may be loaded. The structure to which it is attached does not have that requirement (Ex. 168).

OSHA agrees with Weatherguard. In order for the anchor to support the

minimum 6,000 pound load, so must the structure to which it is attached. Therefore, OSHA removed the language because it is not necessary.

Final paragraph (e)(2)(iv) like proposed paragraph (e)(2)(vi), requires employers to ensure that window anchors are not used for any purpose other than attaching window cleaners' belts. Window anchors are built for the specific purpose of supporting a worker using a window cleaner's positioning system and OSHA believes they must only be used for their intended purpose. Using the anchors for other purposes may cause deterioration that could result in failure of the anchor when window cleaners then use the anchors. The requirement is consistent with I-14.1-2001 (Section 10.2.1). There were no comments on this provision and it is finalized with only minor editorial revisions for clarity.

Final paragraph (e)(2)(v), like the proposed rule, requires employers to ensure window anchors that have damaged or deteriorated fastenings or supports are removed, or the window anchor head is detached so the anchor cannot be used. If damaged or deteriorated anchors are not removed and replaced, the anchor may fail or break when a window cleaner's positioning system is attached, which could lead to the worker falling and being seriously injured or killed. There were no comments on this provision and it is finalized with editorial revisions for clarity.

Final paragraph (e)(2)(vi), like proposed paragraph (e)(2)(iv), requires employers to ensure rope that has wear or deterioration that affects its strength is not used. OSHA believes that deterioration or wear that significantly reduces a rope's strength may lead to worker death or injury if that rope fails. OSHA realizes that some minimal wear may occur on the sheath of modern kernmantle rope during normal use. That type of wear is expected during the life of the rope, however, if the sheath is so damaged as to expose the core of the rope (which could lead to damage), or other such damage affects the strength of the rope, that rope must be retired and no longer used by workers. There were no comments on this provision and it is finalized with minor editorial revisions for clarity.

Final paragraph (e)(2)(vii), like the proposed rule, requires employers to ensure both terminals of the window cleaner's belt are attached to separate window anchors during any cleaning operation. When the worker is moving into position, entering, or exiting the building or structure before or after cleaning, or traversing to another

window, it is not always possible to have both terminals attached to separate window anchors; however, while cleaning the window the terminals must be attached to separate anchors. This requirement is consistent with I-14.1-2001 (Section 5.3.9). There were no comments on this provision and it is carried forward to the final rule with only minor editorial changes.

Final paragraph (e)(2)(viii) requires employers to ensure that no employee works from a window sill or ledge on which there is snow, ice, or any other slippery condition, or one that is weakened or rotted. As in other OSHA requirements (e.g., § 1910.22(a), (b), and (d)) the Agency believes that clean, dry, and firm footing is essential to avoiding slips and falls that may cause injury to workers. This final provision is consistent with I-14.1-2001 (Section 5.3.2). There were no comments on this provision and it is adopted with minor revisions to provide more clarity.

Final paragraph (e)(2)(ix) of the final rule prohibits employers from allowing window cleaning work on a window sill or ledge unless:

- The sill or ledge is a minimum of 4 inches wide and slopes no more than 15 degrees below horizontal (final paragraph (e)(2)(ix)(A)); or,
- The 4-inch minimum width of the sill or ledge is increased 0.4 inches for every degree the sill or ledge slopes beyond 15 degrees, up to a maximum of 30 degrees (final paragraph (e)(2)(ix)(B)).

OSHA believes that this requirement presents the minimum sill or ledge width necessary for workers using window cleaners' positioning systems to safely perform their tasks. This provision is consistent with the A39.1 standard (Section 3.8). No comments were received on this provision and it is adopted with minor revisions for clarity.

Final paragraph (e)(2)(x) requires employers to ensure that the worker attaches at least one belt terminal to a window anchor before climbing through the window opening, and keeps at least one terminal attached until completely back inside the window opening. This provision ensures that the worker is securely attached to at least one anchor before going outside the building and being exposed to a fall. This provision has been revised from the proposed rule for clarity and is also consistent with I-14.1-2001 (Section 5.3.8 and 5.3.10). No comments were received on this provision and it is adopted as discussed.

Final paragraph (e)(2)(xi), like proposed paragraph (e)(2)(xi)(A), requires that employers ensure workers travel from one window to another by returning inside the window opening

and repeating the belt terminal attachment procedures at each window as described in final (e)(2)(x), except as provided in paragraph (e)(2)(xii). OSHA believes that it is safer for workers to return to the inside of the building after cleaning a window and re-exit the building at the next window to be cleaned (when using a window cleaner's positioning system) in the vast majority of circumstances. In certain circumstances, the Agency allows travel outside the building, which are described in final paragraph (e)(2)(xii). This provision has been revised from the proposed rule for clarity and also is consistent with I-14.1-2001 (Section 5.3.11). OSHA notes that final paragraph (e)(2)(xii), discussed below, allows workers to move from one window to another while outside the building in certain circumstances. OSHA did not receive any comments on the proposed rule and adopts it with editorial clarifications.

Final paragraph (e)(2)(xii), similar to proposed paragraph (e)(2)(xi)(B), specifies that employers may allow workers to move from one window to another while outside of the building provided:

- At least one window cleaner's belt terminal is attached to a window anchor at all times (final paragraph (e)(2)(xii)(A));
- The distance between window anchors does not exceed 4 feet horizontally. The distance between window anchors may be up to 6 feet horizontally if the window sill or ledge is at least 1 foot wide and the slope is less than 5 degrees below horizontal (final paragraph (e)(2)(xii)(B));
- The sill or ledge between windows is continuous (final paragraph (e)(2)(xii)(C)); and
- The width of the window sill or ledge in front of the mullions is at least six inches wide (final paragraph (e)(2)(xii)(D)).

OSHA believes that all of these conditions must be present and requirements must be met to ensure workers are protected from falling when they move from window to window on the outside of the building. These requirements, for example, ensure that workers always have a continuous walking-working surface (*i.e.*, window sill or ledge) when they move from one window to another and the width and angle of that surface is sufficient so workers are able to maintain firm footing while traversing between windows. The final rule is consistent with I-14.1-2001 (Section 5.3.11).

Final paragraph (e)(2)(xii) differs from the proposed rule in two respects. First, the final rule deletes the proposed

requirement prohibiting workers from moving from one window to another on the outside of the building if a window unit is not "readily accessible." Final paragraph (e)(2)(xii)(B) more clearly specifies what OSHA intends by window units being readily accessible; therefore, OSHA does not believe the proposed provision is necessary. Second, the final rule reorganizes and restates the proposed requirement so it is easier for employers to understand and follow. OSHA did not receive any comments on the proposed rule and adopts as discussed.

Appendices to § 1910.140 (Non-Mandatory)

OSHA added two appendices to § 1910.140 that provide information, guidance, and examples pertaining to the types of personal fall protection systems this section regulates. These appendices are not mandatory; *i.e.*, they do not establish any additional obligations, nor impose or detract from any obligations, in § 1910.140.

Appendix C provides information and guidance concerning the use of personal fall protection systems. The information includes considerations for planning, selection of personal fall protection systems, worker training, and maintenance and inspection of personal fall protection systems. Appendix D provides test methods for personal fall arrest and positioning systems.

OSHA drew the appendices from the OSHA construction fall protection standards (29 CFR part 1926, subpart M), which the Agency issued in 1994. OSHA based the appendices in the construction fall protection standards on national consensus standards. In addition, experts on OSHA's construction staff, including engineers, assisted in developing the guidance and test methods in the appendices.

OSHA revised the proposed appendices for several reasons. First, some of the language and terms in the proposed appendices were geared to the construction industry. For example, the proposed appendices used "rebar hooks," which are not used in general industry. OSHA revised the appendices to incorporate language and terms that are familiar to general industry employers and workers and are used in the regulatory text of § 1910.140.

Second, OSHA updated the proposed appendices with information that has become available since OSHA published the construction fall protection standard. For example, Appendix C includes information about the danger of orthostatic intolerance due to prolonged suspension in a personal fall protection system.

Third, OSHA also made changes to the proposed appendices to incorporate recommendations commenters suggested. Those additions are discussed below.

Fourth, OSHA reorganized some of the sections of Appendix C so they follow the same order as the regulatory text of § 1910.140. The Agency believes this reorganization will help employers locate more quickly the information they need to comply with the final rule.

Finally, OSHA made revisions to the appendices to comply with the goals of the Plain Writing Act of 2010 (PWA) (Pub. L. 111-274, enacted January 5, 2010). It was only after OSHA published the proposed rule and appendices that the requirements of the PWA applied to the Agency. The PWA requires that OSHA use plain writing in every "covered document" of the Agency that it issues or substantially revises (Pub. L. 111-274, sec. 4(b)). The PWA defines covered documents as "any document that explains to the public how to comply with a requirement that the Federal Government administers or enforces" (Pub. L. 111-274, sec. 3(2)(iii)). Since the purpose of these non-mandatory appendices is to help employers comply with the new rule, they meet the PWA's definition of "covered documents." OSHA believes the revisions to the proposed appendices will make them easier to understand and use, thereby increasing compliance with the final rule.

Appendix C to Subpart I of Part 1910—Personal Fall Protection Systems Non-Mandatory Guidelines

OSHA requested comment on whether any of the provisions in appendix C should be included in the regulatory text of § 1910.140, and whether the appendices should include other information.

NIOSH recommended that OSHA consider adding the following information to appendix C regarding harness sizes: "The employer should ensure sufficient body harness sizes and configurations to accommodate diverse body sizes and shapes in the workforce." NIOSH added:

There have been significant changes in body dimensions among the U.S. civilian population over the last several decades. The diverse workforce in the construction workforce by gender and ethnicity showed a greater variation in range of body dimensions and shapes compared to that in the 1970s and 1980s [citations omitted]. The modern full body harness has evolved to become a more comfortable, easy-to-use body support system that offers a high level of security for a variety of work tasks at height [citations omitted]. Sufficient body harness sizes and configurations to accommodate diverse body

sizes and shapes in the workforce are a critical step to reduce the risk of injury that results from poor user fit and improper size selection. The overall combination of a worker's body dimensions governs the best fit body harness size; body weight and stature alone do not define the best fit (Ex. 164).

OSHA agrees with NIOSH's suggestion and added information to Appendix C recommending that employers consider a broader anthropometric range when selecting personal fall protection systems, including harnesses.

Many commenters from the outdoor advertising industry (Exs. 75; 80; 81; 82; 87; 90; 92; 102; 104; 119; 120; 143) opposed including a list of "approved equipment" in Appendix C because employers should be able to use newer or improved safety devices as they become available rather than waiting for devices to be approved in a "lengthy bureaucratic process." For example, Chris McGinty said:

[T]here is some consideration of the creation of a "list" of approved equipment. I suggest that this would be an error due to the reality of a safety products industry that is constantly designing, testing and introducing improved or enhanced safety devices. . . . By trying to control the exact brands and models allowable, such a program would invariably be months behind technology and might indirectly lead to losses (Ex. 143).

Appendices C and D do not include a list of approved equipment, systems, components, or devices. In 1999, the Agency reiterated its long held position regarding equipment approval:

OSHA does not approve, endorse, or recommend any particular manufactured product because the manufacturer cannot ensure how the product will be used. The final determination of compliance with OSHA's standards must take into account all factors pertaining to the use of such product at a particular worksite with respect to employee safety and health. This must include an evaluation, through direct observation, or employee work practices and all conditions in the workplace. Therefore, under the Occupational Safety and Health Act of 1970, only the employer is responsible for compliance with the Act and for the safe use of any product by their employees (letter to Ron Oxentenko from Richard Fairfax, Directorate of Compliance Programs, September 17, 1999).⁸⁴

The final rule lists the requirements that employers are responsible for ensuring their personal fall protection systems meet. Appendices C and D both provide guidance that employers may use in evaluating whether the personal fall protection system they are

considering will meet the requirements in the final rule.

Regarding paragraph (h) of appendix C, ITA expressed concern about mentioning self-rescue equipment (*e.g.*, equipment with descent capability). ITA was concerned that referring to such equipment would emphasize employee rescue in the design of PPE when, for example, PPE used on powered industrial truck platforms does not currently include self-rescue equipment. ITA believes any mention of self-rescue equipment in Appendix C would have a significant impact in the market, and cautioned OSHA to ensure that such an impact would not occur (Ex. 145).

OSHA does not agree that mentioning self-rescue equipment will cause a significant impact on the market. This equipment has been marketed and readily available for a number of years. OSHA's Powered Platforms standard, issued in 1989, requires that employers provide for prompt rescue or "shall assure the self-rescue capability of employees" (§ 1910.66, appendix C, Section I(e)(8)). The construction (1994) and shipyard employment (1996) standards contain the same requirement (§§ 1926.502(d)(20); 1915.159(c)(7)).

In 2000, OSHA responded to an inquiry from Mr. Charles Hill with Southwestern Bell Telephone Company, chair of the National Telecommunications Safety Panel, about whether employers must provide self-rescue equipment when working in bucket trucks and aerial lifts. In 2004, OSHA published a Safety and Health Information Bulletin on Suspension Trauma/Orthostatic Intolerance (SHIB 3-24-2004, updated 2011) that identified self-rescue equipment. The proposed rule also discussed self-rescue equipment for personal fall protection systems (75 FR 28910).

OSHA believes that employers, including members of ITA, are aware of self-rescue equipment and likely have been aware of such equipment for some time. In the past decade, OSHA has not seen any data suggesting that employer awareness of self-rescue equipment has resulted in an adverse impact on the market, nor did ITA provide such data in its comment. Therefore, OSHA does not believe there is likely to be an adverse impact now.

ITA also requested OSHA "clarify the circumstances when [self-rescue equipment is] deemed to be necessary" (Ex. 145). OSHA stresses that neither the final rule nor the appendices require that employers provide self-rescue equipment. Rather, the final rule requires that employers provide for "prompt rescue" of workers in the event of a fall. To ensure rescue is prompt,

employers may use self-rescue equipment, but they also may provide prompt rescue through other means (see detailed discussion of "prompt" rescue in the explanation of § 1910.140(c)(21) above).

With regard to paragraph (i) of Appendix C on "Tie-off considerations", Ellis suggested that OSHA "point out the drastic consequences of allowing a SRL [self-retracting lifeline or lanyard] cable or web that passes over almost any edge except wood will break unless there is an energy absorber at the hook end" (Ex. 155). OSHA agrees that the potential for breakage is greater in the circumstance Ellis describes and believes the language of paragraph (i)(2) of appendix C adequately addresses his concern. OSHA believes that system manufacturers also include such a warning in their instructions and recommendations.

Regarding paragraph (j) of appendix C, Verallia commented that recommending use of "extreme care" for horizontal lifelines is "too subjective and vague" to be consistently applied or enforced, and that OSHA should clarify or remove the language. OSHA disagrees with this comment. The paragraph on horizontal lifelines says employers should use extreme care in doing a specific task, using multiple tie-offs in horizontal lifelines. The paragraph then explains specifically why employers need to use extreme care (*i.e.*, the movement of one employee falling from a horizontal lifeline may cause other employees to fall). OSHA also explains what employers should do to minimize the hazard. Finally, because of the hazards associated with horizontal lifelines, OSHA explains that qualified persons must design, install, and supervise the use of personal fall protection systems that use horizontal lifelines (§ 1910.140(c)(11)(i)). OSHA believes the appendix and standard are clear, and that employers will be able to understand and comply with the requirements on horizontal lifelines in § 1910.140(c)(11).

In addressing paragraph (n) of appendix C, Verallia asserted that the statement in this paragraph notifying employers that they should "be aware" that a personal fall protection system's maximum fall arrest force is evaluated under normal use conditions is too vague, and recommended that this statement be clarified if an employer is going to be potentially subject to enforcement for lack of awareness. OSHA does not agree with Verallia's comment. Not only does paragraph (n) indicate that employers need to understand that testing personal fall

⁸⁴ Available on OSHA's website at: https://www.osha.gov/pls/oshaweb/owadisp.show_document?p_table=INTERPRETATIONS&p_id=22784.

protection systems is to be performed under normal conditions, but appendix C also reminds employers of this testing requirement. OSHA believes the multiple references to testing personal fall protection systems under normal use conditions are clear and understandable. OSHA also notes that the appendices to § 1910.140 are not mandatory.

Appendix D to Subpart I—Test Methods and Procedures for Personal Fall Protection Systems Non-Mandatory Guidelines

OSHA asked for comment on test methods in appendix D, and whether the Agency should include any test methods in the regulatory text of § 1910.140 or test methods and procedures in Appendix D, and whether any of the test methods need updating.

Ameren recommended that OSHA delete the test methods in appendix D because product testing rests with the manufacturer instead of the end user. Ameren also said that if OSHA believes it is necessary for employers to test their personal fall arrest systems, appendix D should add an option allowing employers to test systems “per manufacturer’s instructions” (Ex. 189). Ameren explained:

Testing of fall protection lies more with the manufacturer of the equipment and less with the end user, whereas the inspection and checking of the equipment lies with the user. As long as a manufacturer is required to meet certain standards prior to selling their products, there should be no need for post purchase testing, hence no requirement for detailed, outlined testing instructions for the employer (Ex. 189).

OSHA does not agree with Ameren’s recommendation for several reasons. First, although the final rule does not require that employers personally test the personal fall protection systems they use, some employers conduct their own tests to ensure that systems and equipment meet the requirements of OSHA standards. Appendix D gives those employers the information and flexibility they need to conduct tests on personal fall protection systems.

Second, the final rule and appendices do not require employers to test personal fall protection systems. Employers are free to select personal fall protection systems that manufacturers have tested rather than testing them themselves. However, employers are ultimately responsible for ensuring that the systems they provide to their workers meet the requirements of § 1910.140. Manufacturer instructions and specifications often will explain that equipment or systems have been tested and meet the requirements of an

OSHA or national consensus standard. However, when the manufacturer has not tested the system according to appendix D or other recognized test methods, or does not affirm that the system meets the requirements of § 1910.140, then employers cannot use the system without verifying independently that it meets the requirements of § 1910.140. Using such a system without verifying its safety puts workers at risk of harm.

Finally, OSHA stresses that appendix D and the test methods in it are not mandatory. Employers are free to use personal fall protection systems that have been tested using other methods, provided those test methods ensure the systems meet the requirements in § 1910.140.

Penta Engineering Group, Inc. recommended that OSHA add several test methods in appendix D:

ANSI/IWCA 1–14.1–2001 requires testing anchors by applying a minimum static load of twice the design load in each (primary) direction that the load might be applied and that this outlines a good generic method adequate for load testing tie-back safety anchors at most buildings. Also included in the ANSI/IWCA I–14.1–2001 is that any testing procedure should be developed and performed under the direction of a registered professional engineer. This language should also be part of the proposed rule (Ex. 193.)

OSHA does not believe it is necessary to add test methods in I–14.1 to appendix D. The test methods in appendix D are not mandatory, and personal fall protection systems can be tested using other recognized tests, such as those tests specified in national consensus standards such as I–14.1, provided those test procedures ensure that the systems meet the requirements in § 1910.140. OSHA also does not believe it is necessary to include in the final rule or in Appendix D Penta’s recommendation that tests methods be developed and performed under the direction of a registered professional engineer. The test methods in appendix D were developed by experts, including engineers. OSHA believes that testing organizations and manufacturers also test systems under the supervision of experts and qualified persons, which likely include engineers.

SPRAT offered another suggestion regarding test methods. They recommended that OSHA accept markings on equipment as meeting the ANSI Z359 family of standards. They said this would help to ensure test methods and equipment are consistent with and meet current national consensus standards.

OSHA does not agree. The Agency does not have the resources to ensure all

manufacturers accurately mark their products. As noted in the final rule and appendices, employers and manufacturers are not required to use the test methods in appendix D. They are free to test personal fall protection systems using other recognized test methods and procedures, including those specified by ANSI and other national consensus standards, provided those test methods ensure that the systems meet the requirements in § 1910.140.

Verallia recommended adding a requirement to paragraph (b)(2) of appendix D requiring that each employee visually inspect anchorage points prior to use (Ex. 171). OSHA does not believe that Verallia’s recommendation is appropriate for appendix D. Appendix D addresses methods employers and manufacturers may use for testing personal fall protection systems to ensure they meet the requirements in § 1910.140 prior to the purchase and use of the systems. Verallia’s recommendation applies to use of personal fall protection systems after the systems are in use in the workplace. However, OSHA notes that paragraph (c)(18) of the final rule addresses Verallia’s recommendation by requiring that the employer ensure the entire personal fall protection system, which the final rule defines to include the anchorage, be inspected before initial use in each workshift. In addition, OSHA added language to Appendix C mentioning this requirement, and included anchorages as one of the examples.

C. Other Revisions to 29 CFR Part 1910

The final rule also includes changes to provisions in subparts F, N, and R of 29 CFR part 1910. Primarily, the changes are technical in nature and are necessary so all sections in part 1910 conform to final subparts D and I.

Most of the changes in subparts F, N, and R update references to final subparts D and I. For example, existing § 1910.265(f)(6)—Sawmills, requires that ladders comply with existing § 1910.27 (Fixed ladders). However, the final rule reorganizes subpart D and the ladder requirements are no longer in § 1910.27. Instead, requirements applicable to ladders are contained in other sections of final subpart D (*i.e.*, §§ 1910.22, 1910.23, 1910.28, 1910.29). To ensure that employers comply with all of the applicable general industry ladder requirements, the final rule revises § 1910.265(f)(6) to specify that ladders must comply with 29 CFR part 1910, subpart D.

Some changes in subparts F, N, and R replace existing references with

references to final subparts D and I. For instance, existing § 1910.66—Powered platforms for building maintenance, specifies that employers provide personal fall arrest systems that comply with Appendix C of that section (existing paragraph (f)(5)(ii)(L)). Appendix C established provisions for the use of personal fall arrest systems because, at the time OSHA promulgated § 1910.66, the general industry fall protection requirements did not allow employers to use personal fall arrest systems, as defined in final §§ 1910.21(b) and 1910.140(b). Final subpart D adds provisions allowing employers to use personal fall arrest systems, and final subpart I establishes performance, use, and care criteria for those systems. In conjunction with those revisions to subparts D and I, OSHA revises § 1910.66 to specify that employers comply with the requirements in final subpart I instead of those in appendix C. With the addition of the personal fall arrest system provisions to final subpart I, § 1910.66 Appendix C is no longer necessary; accordingly, the final rule deletes it.

Similarly, in final § 1910.269(c)(2)(i) OSHA replaces references to personal fall arrest system provisions in 29 CFR part 1926, subpart M—Fall Protection, with citations to the personal fall protection requirements in final subpart I.

Finally, the final rule revises subpart F (§ 1910.67(c)(2)(v)) to require that employees wear either a personal fall arrest system or travel restraint system that complies with final subpart I when they are working from an aerial lift. Existing § 1910.67(c)(2)(v) allows employees to wear a body belt and lanyard for fall protection in aerial lifts while the proposed rule would have required that aerial lift operators use a “positioning system” or personal fall arrest system. Neither the existing nor proposed rules are consistent with OSHA general industry (§§ 1910.140 and 1910.269) and construction standards (§§ 1926.453, 1926.502, and 1926.954). To resolve this discrepancy, in final § 1910.67(c)(2)(v) OSHA revises the existing and proposed rules in two ways.

First, final § 1910.67(c)(2)(v) eliminates the existing requirement, which specifies that employees use body belts and lanyards for fall protection when working from aerial lifts, because it is not consistent with final subpart I (final § 1910.140(d)(3)). Final subpart I, like the construction fall protection standard (§ 1926.502(d)), prohibits the use of body belts as part of a personal fall arrest system. OSHA

has determined, as the Agency did in the construction fall protection rulemaking (59 FR 40672 (8/9/1994)), that body belts must be prohibited because they do not afford a level of protection equivalent to body harnesses and present unacceptable risks in fall arrest situations. Specifically, as OSHA discussed in the explanation of § 1910.140, fall arrest forces are more concentrated for a body belt than a body harness, therefore, the risk of injury in a fall is much greater when workers use a body belt. In addition, in a fall, workers are more likely to slip out of a body belt than a body harness and be killed or seriously injured. Moreover, if a fall occurs, the hazards associated with prolonged suspension in a body belt are substantially more severe than suspension trauma associated with body harnesses. (Also see discussion of the prohibition of body belts in the preamble revising the general industry and construction Electric Power Generation, Transmission, and Distribution and Electric Protective Equipment standards (hereafter referred to as “subpart V”) (79 FR 20316, 20383–88 (4/11/2014)).

To make final § 1910.67(c)(2)(v) consistent with final subpart I, OSHA replaces the existing provision with the requirement that workers use a personal fall arrest system or travel restraint system that meets the requirements of final subpart I when working from an aerial lift. This revision also makes final § 1910.67 consistent with the construction aerial lift (§ 1926.453(b)(2)(v) note 1) and fall protection standards (§ 1926.502(d)) as well as subpart V (§§ 1910.269(g)(2)(iv)(C)(1) and 1926.954(b)(3)(iii)(A) (79 FR 20640, 20700)).⁸⁵

OSHA notes that final subpart I (final § 1910.140(b) and (d)(3)), like the construction aerial lift and fall protection standards, allows the use of body belts with a travel restraint system when employees work from an aerial lift (*See also* letter to Mr. Jessie L. Simmons (5/11/2001)⁸⁶). OSHA allows the use of a body belt with a travel restraint system because the system “prevents a worker from being exposed to any fall” (Letter to Mr. Charles E. Hill (8/14/2000)). To ensure that employees using travel

restraint systems in aerial lifts are protected, the employer must ensure the lanyard and anchor are arranged so workers are not potentially exposed to falling any distance.

Second, final § 1910.67(c)(2)(v) revises the proposed rule to require that employees must use a personal fall arrest system or travel restraint system when working in an aerial lift. The proposed rule specified, mistakenly so, that employees use a personal fall arrest system or “positioning system” for fall protection when they work from an aerial lifts. In actuality, OSHA does not permit employees to use positioning systems when working from an aerial lift (Letters to Mr. Jessie L. Simmons (5/11/2001) and Mr. Charles E. Hill (8/14/2000)). A positioning system is defined in the proposed and final rules as a system that support employees on an elevated “vertical” surface, such as a wall or window sill (final §§ 1910.21(b) and 1910.140(b)). However, employees working from aerial lifts are on horizontal surfaces. Positioning systems are “designed specifically to stop a worker from falling from a static, head-up position” (Letter to Mr. Jessie L. Simmons (5/11/2001)); however, falls from a horizontal surface, such as an aerial lift, can begin with the worker in other than a static, head-up position (Letter to Mr. Jessie L. Simmons (5/11/2001); also see, 79 FR 20384). The final rule corrects the proposed rule and, in so doing, makes final § 1910.67(c)(2)(v) consistent with subpart V (§§ 1910.269(g)(2)(iv)(C)(1) and 1926.954(b)(3)(iii)(A) (79 FR 20640, 20700)).⁸⁷

OSHA received several comments on the proposed revision of § 1910.67(c)(2)(v) (Exs. 59; 174; 183; 207). Darren Maddox, with Central Alabama Electric Coop (CAEC), supported requiring the use of personal fall arrest systems when employees work from aerial lifts (Ex. 59). He pointed out positioning straps do not provide fall protection, and that CAEC’s employees now use personal fall arrest systems when working in aerial lifts (Ex. 59). Edison Electric Institute, on the other hand, said OSHA should not require fall protection for employees working in bucket trucks (Ex. 207).

The Utility Line Clearance Coalition (ULCC) and Tree Care Industry Association (TCIA) both recommended

⁸⁵ Since final § 1910.67(c)(2)(v) and § 1910.269(g)(2)(iv)(C)(1) are consistent, OSHA is eliminating the sentence in § 1910.269(g)(2)(iv)(C)(1) stating that final § 1910.67(c)(2)(v) does not apply. OSHA believes the sentence is not necessary and deleting it eliminates any potential for confusion.

⁸⁶ Letter available on OSHA’s Web site at: https://www.osha.gov/pls/oshaweb/owadisp.show_document?p_table=INTERPRETATIONS&p_id=24360.

⁸⁷ Stakeholders commenting to the proposed rule appeared to recognize that OSHA’s reference to positioning systems might be an error (Exs. 174; 183). For example, ULCC pointed out that the proposed definition of positioning systems does not appear to be applicable to line clearance work from aerial lifts because employees are not working on an elevated vertical surface (Ex. 83).

that OSHA allow employers to use body belts and short lanyards (3-foot maximum length) when their employees work from aerial lifts (Exs. 174; 183). TCIA contended that arborists and line-clearance tree trimmers (collectively referred to as “line-clearance arborists”) often work in aerial lifts above high voltage wires and using body belts and lanyards provides the “greatest protection” against falling into energized power lines (Ex. 174). In addition, they said using a body belt with a short lanyard (*i.e.*, 3 feet)⁸⁸ “provides for the shortest overall fall distance,” which reduces free fall distances, and thus, fall arrest forces, as well as minimizing the risk of falling into power lines (Ex. 174). TCIA also said that body belts attached at the waist allow for “the possibility of self-rescue,” but did not provide further explanation (Ex. 174).

ULCC raised similar arguments supporting the use of body belts and lanyards when line-clearance arborists work from aerial lifts, particularly above power lines. They contended that using belts and lanyards in those situations has not resulted in undue risk to employees and requiring that employees use body harnesses, which typically have longer lanyards, would increase the risk of contact with power lines (Ex. 183). ULCC also argued that using body harnesses puts line-clearance arborists at greater risk of injury from falling into tree limbs and stubs from “reduction cuts” (Ex. 183). In addition, they contended line-clearance arborists feeding limbs and brush into chippers are a greater risk of serious injury or death because longer lanyards typically used with body harness could get dragged into the chipper.

ULCC also argued that the proposed rule does not provide an explanation for eliminating the use of body belts and lanyards when working from aerial lifts and fails to provide fall protection options for line-clearance work performed from aerial lifts.

TCIA and ULCC raised these same issues and arguments in the subpart V rulemaking and OSHA addressed them in great detail in the preamble to that final rule (79 FR 20383–88). OSHA did not find TCIA’s and ULCC’s arguments in the subpart V rulemaking to be convincing and nothing in their

comments in this rulemaking changes OSHA’s conclusion. Since TCIA’s and ULCC’s comments in this rulemaking are the same as those they made in the subpart V rulemaking, OSHA incorporates by reference the explanation OSHA provided in final subpart V and need not repeat that full discussion here. For the following reasons, consistent with final subpart V, OSHA has not adopted TCIA’s and ULCC’s recommendation that employers be permitted to use body belts and lanyards when their employees work from aerial lifts.

First, OSHA does not find persuasive TCIA’s and ULCC’s argument that body harnesses (*e.g.*, personal fall arrest systems) pose a greater hazard (*e.g.*, falling into an energized power line) than body belts and lanyards when employees, including line-clearance arborists, work from aerial lifts. As mentioned in the explanation of § 1910.140(d)(3) and closely examined in the construction fall protection rulemaking (59 FR 40702–03), body belts do not provide the level of protection that full body harnesses do. Body belts, unlike harnesses, expose workers to greater fall arrest forces and suspension trauma and significant hazards of slipping out of the body belt. In addition, TCIA’s recommendation that OSHA allow employers to use body belts with 3-foot lanyards, instead of the required 2-foot lanyard, would expose workers to even greater fall arrest forces. In addition, ULCC’s admission that some member employers “mandate full body harnesses and lanyards” undercuts their argument that using body harnesses, instead of body belts, exposes workers to “significantly increased risk, especially when working above energized power lines” from an aerial lift (Ex. 183).

Second, TCIA’s and ULCC’s unsupported claim that body belts allow workers to self-rescue is not correct. To the contrary, body belts significantly reduce the possibility of self-rescue after a fall because of the increased probability of serious internal injuries sustained from the initial impact forces, from body belt suspension trauma (especially unconscious suspension), or both.

Third, as discussed in detail in the preamble to final subpart V, OSHA does not consider the risk of falling into power lines to be as serious as TCIA and ULCC portray. Line-clearance arborists do not always work directly over power lines; they may work at the same height, below or to the side of power lines. In any event, stakeholders in the subpart V rulemaking said employers can reduce the risk of falling into power lines,

without exposing workers to greater arrest forces and suspension trauma, by using personal fall arrest systems that have shorter lanyards (79 FR 20385).

Fourth, ULCC’s argument that using body harnesses with longer harnesses puts line-clearance arborists at risk of getting caught in a chipper is unpersuasive. The final rule does not require that line-clearance arborists wear harness when they are not working on an elevated surface (*i.e.*, when working on the ground). Therefore, employers can eliminate that risk by requiring that line-clearance arborists remove their harnesses when using the chipper.

Employers also can reduce the risk by providing line-clearance arborists with harnesses that have a shorter lanyard.

Fifth, final § 1910.67(c)(2)(v), like subpart V (§ 1910.269(g)(2)(iv)(C)(1) and § 1926.954(b)(3)(iii)(A) (79 FR 20640, 20700)) provides employers with two options for protecting employees working in aerial lifts. They may use either a personal fall arrest system or travel restraint system. As mentioned, employers can use personal fall arrest systems that have a short lanyard. Also, since travel restraint systems must prevent a fall of any distance, the final rule allows employers to use either a body belt or body harness with travel restraint systems. OSHA notes, however, that a travel restraint system rigged to allow free fall even a small distance (*e.g.*, 2 feet) would not be an acceptable system under the final rule. For further discussion of the requirement that employers ensure employees use a personal fall arrest system or travel restraint system when working from an aerial lift, see preamble to final subpart V (79 FR 20383–88).

V. Final Economic and Final Regulatory Flexibility Screening Analysis

A. Introduction

This collection of final standards governing occupational exposure to slip, trip, falling-object and fall hazards on walking and working surfaces is a “significant regulatory action” under Executive Order 12866. Accordingly, the Office of Regulatory Analysis within OSHA prepared this Final Economic and Final Regulatory Flexibility Screening Analysis (FEA) for the final standard. In developing the FEA, OSHA, to the extent possible given the available resources, endeavored to meet the requirements of OMB’s Circular A–4 (OMB, 2003), a guidance document for regulatory agencies preparing economic analyses under Executive Order 12866. In addition to adherence to Executive

⁸⁸ OSHA notes that final § 1910.140(e)(1)(i)(B) requires that positioning systems must be rigged to prevent the worker from free falling more than 2 feet. Therefore, TCIA’s recommendation that line-clearance arborists be allowed to use 3-foot lanyards is not permitted under the final rule. OSHA also notes that as of April 1, 2015, § 1926.954(b)(3)(iv) requires that work-positioning systems be rigged so workers cannot free fall more than 2 feet.

Order 12866, OSHA developed this final rule with attention to the approaches to rulemaking outlined in Executive Order 13563.

This FEA addresses issues related to the costs, benefits, technological and economic feasibility, and economic impacts (including small business impacts) of the Agency's final revisions to subpart D, Walking-Working Surfaces, and subpart I, Personal Protective Equipment. OSHA's final feasibility and impact analysis builds upon the preliminary economic analysis that OSHA developed in support of the proposed standard and the record developed in this rulemaking. The analysis also evaluates regulatory alternatives to the final rule. The Office of Information and Regulatory Affairs in the Office of Management and Budget reviewed this rule as required by Executive Order 12866. Terminology, analytic methods, and standards appearing in a particular section of this FEA correspond to the source(s) of that section's requirements; for example, the legal concept of "economic feasibility," which is a key subject of section V.G, is not recognized in E.O.s 12866 or 13563 or their associated guidance document, OMB Circular A-4. OSHA uses legal concepts, appropriate under the OSH Act and associated case law but distinct from any concepts in Circular A-4, in discussing economic feasibility (see Section III—Pertinent Legal Authority). Furthermore, OSHA discusses how benefit and cost estimates may differ given the differing analytic approaches set forth by the OSH Act, as interpreted in case law, and Circular A-4.

The purpose of the FEA is to:

- Identify the establishments and industries potentially affected by the final rule;
- Estimate current exposures to slip, trip, and fall hazards in general industry, and assess the technologically feasible methods of controlling these exposures;
- Estimate the benefits of the rule in terms of the number of worker deaths and injuries that employers will prevent by coming into compliance with the standard;
- Evaluate the costs that establishments in the regulated community will incur to achieve compliance with the rule;
- Assess the economic impacts and the economic feasibility of the rule for affected industries; and
- Evaluate the principal regulatory alternatives to the final rule that OSHA considered.

The Regulatory Flexibility Act (5 U.S.C. 601 *et seq.*) requires that a final regulatory flexibility analysis (FRFA) be

prepared if an agency determines that a rule will impose a significant economic impact on a substantial number of small entities. To determine the need for a FRFA, OSHA voluntarily prepared a final regulatory flexibility screening analysis that identifies and estimates the impacts of the final standard on small businesses. Based on the screening analysis, presented in the last section of this FEA, the Assistant Secretary certifies that the final rule will not have a significant economic impact on a substantial number of small entities.

This FEA contains the following sections in addition to this Introduction:

- Assessing the Need for Regulation
- Industry Profile
- Benefits, Net Benefits, Cost Effectiveness, and Sensitivity Analysis
- Technological Feasibility
- Costs of Compliance
- Economic Impacts
- Final Regulatory Flexibility Screening Analysis

To develop the FEA, OSHA relied considerably on (1) the record created throughout the history of this rulemaking, (2) an analysis by OSHA's contractor, Eastern Research Group (ERG) (ERG, 2007), and (3) OSHA's Preliminary Economic Analysis (PEA) supporting the Walking-Working Surfaces NPRM and published in the **Federal Register** notice announcing the proposed standard (OSHA, 2010).

1. Reasons for Agency Action

Earlier in this preamble OSHA discussed the major revisions to the existing standards for walking-working surfaces and personal protective equipment (subparts D and I of part 1910) finalized by this rulemaking. OSHA designed the final standards to prevent a significant number of slips, trips, and falls that result in injuries and fatalities in general industry, including falls from ladders, roofs, scaffolds, and stairs.

The final standard also addresses hazards associated with falling objects. However, as noted below in Section D. Benefits, Net Benefits, Cost Effectiveness, and Sensitivity Analysis, and Section F. Costs of Compliance, because the final standard introduces no additional burden on employers beyond existing requirements, and because there were no comments in the record suggesting that additional economic impacts would result, OSHA expects that the final falling-object provisions will involve no new costs or benefits.

Some examples from OSHA's inspection database (OSHA, 2012a and 2007), provided in the following paragraphs, best illustrate the kinds of

accidents the standards will prevent, and how the revised standards will prevent them.

A repairperson for a specialty metals producer in Pennsylvania was replacing a water cooling panel (approximately 8-ft. high by 12-ft. long) on a basic oxygen furnace vessel. To access the panel, he placed a ladder on an 8-in. diameter pipe. When the employee attempted either to gain access to the panel or to secure the ladder, he fell 22 feet to the ground. He sustained a blunt-force trauma injury to his head and died. OSHA cited and fined the employer for a violation of § 1910.23(c)(1), Protection of open-sided floors, platforms, and runways, and § 1910.25(d)(2)(i), Use of ladders, along with other standards. OSHA believes that the clarifications of the requirements for the safe use of ladders and the duty to have fall protection will prevent accidents such as the one described above (OSHA, 2007, Inspection No. 123317679).

In a window cleaning operation, two employees were working from boatswain's chairs suspended from a roof by two transportable roof rollers; they lowered their chairs down the side of the building using controlled-descent devices. A third employee was on the roof pushing the rollers back and forth to move his coworkers from window to window. The third employee was moving the roller on one end of the building when one of its wheels slipped off the edge of the parapet wall, causing the rollers, which were tied together, to fall between six and seven stories to the ground. The first two employees, with their lifelines attached only to the suspension point on the rollers, also fell to the ground and sustained serious injuries. When one of the rollers went over the edge, it catapulted the third employee off the roof; that employee fell approximately 84 feet to the ground and died from the fall. In the investigation, OSHA determined that the employer did not anchor the rollers to the roof, and cited the employer for violating the general duty clause (Section 5(a)(1)) of the OSH Act. OSHA believes that compliance with the requirements for rope descent systems in the final standard (§ 1910.27(b)) will help to prevent this type of accident (OSHA, 2007, Inspection No. 303207633).

A 49-year-old service technician fractured five vertebrae and eventually died from the injuries received when he fell 11 feet from a fixed ladder to a concrete landing while performing air-conditioning service work on the roof of a shopping mall. OSHA's investigation of the August 24, 2004, accident identified the likely cause as the

absence of uniform spacing between the ladder rungs throughout the climb (the space between the top two rungs/steps was 28 inches, whereas the space between lower rungs was much narrower). Section 1910.23(b)(2) in the final standard requires that, with a few exceptions, the spacing for rungs, cleats, and steps of ladders be not less than 10 inches (25 cm) apart nor more than 14 inches (36 cm) apart, as measured between the center lines of the rungs, cleats, and steps. OSHA believes that compliance with this provision will prevent accidents such as the one described here (OSHA, 2007, Inspection No. 308003953).

As a final example, an employee in a South Dakota feed mill was atop a soybean storage bin gauging the level of the contents when he fell approximately 24 feet onto a concrete surface. The employee suffered head and upper body injuries that resulted in his death. The subsequent OSHA investigation resulted in citations for violations of the general duty clause and provisions in existing subpart D regulating floors, platforms, and railings. OSHA believes that the final revisions to subpart D will remove any ambiguity in the scope or purpose of the rule, which will prevent falls from storage bins and related surfaces (OSHA, 2007, Inspection No. 102761012).

The accidents described above represent a small sample of the many slip-, trip-, and fall-related fatality and injury cases that OSHA's final standards are designed to prevent. Appendix A presents a larger set of preventable fatal workplace accidents taken from the OSHA Integrated Management Information System (IMIS) database for 2006–2010 that involve slips, trips, or falls.⁸⁹ To compile the accident dataset, OSHA searched the IMIS database for fatal work place injuries in general industry resulting from falls. The search excluded SIC codes for Construction, Agriculture, and Water Transportation/Maritime and produced 974 records. Of those 974 records, the dataset in Appendix A focuses on the following types of falls: (1) Falls from ladders (ladders type unspecified, fixed ladders, extension ladders, step ladders, rolling ladders, other ladders); (2) Falls from scaffolds (scaffolds, scaffold ladders); (3) Falls from roofs (roofs, falls through skylights); (4) Falls from walking surfaces (slips, trips); (5) Falls from stairways; (6) Falls involving window washing; (7) Falls involving chimney

work; (8) Falls involving manholes; and (9) Other types of falls. These categories alone represented 290 of the possible 974 fatal fall incidents that would be covered by the D&I standard.

When establishing the need for an occupational safety and health standard, OSHA must evaluate available data to determine whether workers will suffer a material impairment of their health or functional capacity resulting from exposure to the safety or health hazard at issue. Prior to promulgating a standard, the Agency also must determine that “a significant risk of harm exists and can be eliminated or lessened by a change in practices.” See *Industrial Union Dep't v. American Petroleum Institute*, 448 U.S. 607 (1980). See also 58 FR 16612, 16614, (March 30, 1993) (OSHA must conclude that the standard it is promulgating will substantially reduce a significant risk of material harm).

OSHA determined that the best available data for quantitatively estimating the risks associated with slips, trips, and falls in general industry come from the Bureau of Labor Statistics (BLS) injury and illness survey and census. OSHA relies on federal survey and census data from recent years to determine the risk to similarly exposed employees across industry in analyzing other safety standards (e.g., Confined Spaces in Construction at 80 FR 25366 (May 4, 2015)).

Other regulatory and non-regulatory entities for research and policymaking widely accept and use these data sets.⁹⁰

As previously discussed in section II of this preamble (Analysis of Risk), OSHA determined that hazards associated with walking and working on elevated, slippery, or other surfaces pose significant risks to employees, and that the revisions to subparts D and I are reasonable and necessary to protect affected employees from those risks. Based on the BLS data showing the number of injuries and fatalities currently occurring and OSHA's judgments about the percentage of these injuries and fatalities that would be averted as a result of the standards, the Agency estimates that full compliance with the revised walking-working surfaces standards will prevent 29 fatalities and 5,842 lost-workday injuries annually. These benefits constitute a substantial reduction of significant risk of material harm for the exposed population of approximately 5.2 million employees in general industry.

2. Feasibility

The Agency must show that the standards it promulgates are technologically and economically feasible. (See 58 FR 16612.) A standard is *technologically feasible* if the protective measures required already exist, available technology can bring the measures into existence, or reasonable designs and developments in technology can create the measures.⁹¹ Protective measures employers take to comply with safety standards generally involve the use of engineering and work-practice controls. Engineering controls include, for example, ladder safety systems, guardrails, toeboards, or other devices or barriers that protect employees from exposures to slip, trip, and fall hazards. Work-practice controls are techniques that employees use to perform their jobs (for example, safe climbing techniques on ladders). Employers also can use administrative controls (such as job rotation) and personal protective equipment (PPE) (such as harnesses and lanyards) to comply with safety standards.

A standard is *economically feasible* if the cost of meeting it does not threaten the existence or competitive structure of an industry. An OSHA standard may be economically feasible even if it imposes costs that will put some marginal firms out of business.⁹² As discussed in more detail below, OSHA concludes that the final revisions to subparts D and I are both economically and technologically feasible.

3. Methodological Considerations in Development of the FEA

OSHA prepared an economic analysis to estimate the benefits and costs of the revisions to subparts D and I as required by E.O. 12866. Since 2002, under the direction of the Office of Management and Budget, the Agency “monetized” the value of the injuries, illnesses, and fatalities that new standards will prevent, *i.e.*, it monetized the value of expected benefits. Monetized values provide a common metric for both benefits and costs. When preparing an economic analysis in support of a proposed or final rule that is economically significant under E.O. 12866, OSHA presents annual estimates of benefits and costs. The Agency

⁸⁹The IMIS database contains information on over 2.5 million inspections conducted since 1972. The information is continually being updated with new data originating from OSHA federal and state enforcement offices.

⁹⁰See, for example, NIOSH, 2004, and FMCSA, 2010.

⁹¹See *Society of the Plastics Industry v. OSHA*, 509 F.2d, 1301, 1309 (1975); *USWA v. Marshall*, 647 F.2d, 1189 (1980); *American Textile Manufacturers v. Donovan*, 452 U.S. 490 (1981); and *Building and Construction Trades Dept., AFL-CIO v. Brock*, 838 F.2d 1258 (1988).

⁹²See *Industrial Union Dept. v. Hodgson*, 499 F.2d 467 (1974); *USWA v. Marshall*, 647 F.2d, 1189 (1980); and *American Textile Manufacturers v. Donovan*, 452 U.S. 490 (1981).

believes that this approach offers the simplest and clearest way to assess the economic effects of its standards. Computing annual estimates focuses the Agency's analysis on information from current conditions and recent years, which the Agency deems the best, *i.e.*, most accurate and reliable, information. OSHA typically assumes a ten year annualization period for one-time costs associated with a rule.⁹³ In the case of this final rule for subparts D and I, adding additional years to the period of the analysis would not change any major policy conclusions.

To characterize the effects of a new standard, the Agency estimates the costs and benefits expected to accrue as regulated entities move from the current state of affairs to full compliance with the rule. Accordingly, OSHA does not include injuries or fatalities already preventable through compliance with existing regulations in its assessment of the benefits expected from compliance with the new standard. Similarly, the Agency does not include the cost of complying with existing standards in its assessment of what it will cost employers to comply with the new standard. The Agency assumes that all employers will fully comply with the standard. OSHA's analysis also assumes that employers incur all costs in the first year following promulgation of the final standard (with ongoing costs incurred annually beginning in Year 1), and that benefits result immediately.

The Agency employs a "willingness-to-pay" (WTP) methodology to estimate benefits. Data from the BLS provide the number of expected injuries and fatalities occurring currently and assumed to continue into the future in the absence of this regulatory standard, OSHA makes expert judgments about the percentage of these injuries and fatalities averted as a result of the standard, and the Agency uses WTP

⁹³ As discussed later in this FEA, fixed ladders, cages, and wells may have a functional life longer than ten years. However, the fall protection equipment and other safety controls applied in this FEA are assumed to have a life of ten years, and the cost analysis for these controls reflects that lifespan. The Agency estimated that fixed ladders have an average life of 30 years. Replacement of the fixed ladders would occur evenly across the 30-year period, and, with a phase-in date 20 years after publication, some ladders still would require replacement anywhere from 1 to 10 years after the 20-year phase-in date. OSHA calculated first-year costs (at Year 0) of installing ladder safety systems for the annual percentage (3.3 percent each year) of the total stock of fixed ladders (24' to 30' in height) that from Year 21 to Year 30 will no longer meet the requirements of the standard. Then OSHA used a seven percent discount rate to annualize over 10 years. First-year costs total \$8.5 million and annualized costs total \$1.2 million. For further details, see Ex. [OSHA Excel Workbook], tabs retrofit_28_calc and retrofit_28.

estimates from the extant literature to assign monetary values to these injuries and fatalities. OSHA bases its estimates of willingness to pay on empirical studies that statistically analyze the effects of fatality and injury rates on wage rates to arrive at individuals' trade-off between higher wages and an incremental increase in occupational risk. That trade-off allows economists to calculate the implicit value of a statistical life (VSL).⁹⁴ Many government regulatory authorities, such as the National Highway Traffic Safety Administration and the Environmental Protection Agency, use the VSL as a metric, but it is particularly appropriate for occupational regulations since it is derived from occupational risks and wages.

The primary alternative to a WTP approach is a "cost-of-injury" (COI) approach. The COI approach accounts for the various costs to all parties associated with an injury or fatality, including medical costs, the costs of work disruption from accidents and accident investigations, indirect costs to employers (*e.g.*, absenteeism, hiring costs), lost wages or job opportunities, and rehabilitation expenses. The COI approach results in ascribing costs and benefits to many involved entities: The employer, the employee, workers' compensation programs, health insurance providers, federal disability programs, governmental bodies, and taxpayers, among others. A COI approach does not capture the values of pain and suffering, impacts on families, or similar parameters, and for that reason, the Agency believes that WTP is superior.

The Agency's calculation of benefits and costs adopts the perspective of society as a whole. Compliance costs are borne directly by affected employers but these costs may ultimately be borne by a wide variety of parties including employers, consumers, government, and employees. Benefits accrue to employees, families, insurers, and government, as well as to employers.

4. OSHA's Estimates of Benefits, Costs, and Net Benefits

a. Introduction

Employees throughout general industry are exposed to slip, trip, and fall hazards that cause serious injury

⁹⁴ For example, if workers are willing to pay \$50 each for a 1/100,000 reduction in the probability of dying on the job, then the imputed value of an avoided fatality is \$50 divided by 1/100,000, or \$5,000,000. Another way to consider this result is to assume that 100,000 workers made this trade-off. On average, \$5,000,000 would save one life.

For discussion on WTP methodologies, see Viscusi and Aldy (2003).

and death. OSHA estimates that, on average, approximately 202,066 serious (lost-workday) injuries and 345 fatalities occur annually among workers directly affected by the final standard. Although better compliance with existing safety standards may prevent some of these incidents, research and analyses conducted by OSHA found that many preventable injuries and fatalities would continue to occur even if employers were complying fully with the existing standards. Even if there were full compliance with the existing standards, OSHA estimates that full compliance with the final standard will prevent an additional 5,842 lost-workday injuries and 29 fatalities each year.

An additional benefit of this rulemaking is that it will provide updated, clear, and consistent safety standards for walking and working surfaces and personal fall protection equipment. Most of the existing OSHA standards for walking-working surfaces are over 30 years old and inconsistent with both national consensus standards and more recently promulgated OSHA standards addressing fall protection.

Presently, OSHA's standards for fall protection on walking-working surfaces in general industry differ from the comparable standards for construction work. In most instances, employees use similar work practices to perform similar tasks, irrespective of whether they are performing construction or general industry work. Whether OSHA's construction or general industry standards apply to a particular job depends on whether the employer is altering the system (construction work) or maintaining the system (general industry work). For example, replacing an elevated ventilation system at an industrial site would be construction work if it involves upgrading the system, but general industry work if it involves an in-kind replacement. Since the work practices used by the employees would most likely be identical in both situations, it would ease compliance if OSHA's general industry and construction standards were as consistent as possible. Under OSHA's existing requirements, however, different requirements might apply to similar work practices, *e.g.*, an employer overhauling two or more ventilation systems may have to comply with two different sets of OSHA requirements if one project is considered construction and another general industry. The existing inconsistencies between the construction and general industry standards make it difficult for employers to develop appropriate work practices for their employees. Consequently, employers and

employees told OSHA that they would like the two standards to match more closely. This final rule achieves that result.

OSHA neither quantified nor monetized several other benefits of the final standard. First, OSHA did not estimate the number of fall injuries prevented that do not result in lost workdays. Second, OSHA did not estimate the improvements in efficiency of compliance associated with clarifying the existing rule and making it consistent with current national consensus standards.

OSHA's benefit estimates are most sensitive when it comes to estimating the percentage of current injuries and fatalities that full compliance with the final standard will avoid. The true benefits of the final standard depend on how well the cases reviewed represent actual fall-related fatalities in general industry.

The Agency believes that its estimate of about 345 annual fatalities in general industry involving slips, trips, and falls

is more certain than the estimate of the percentage of fatalities avoided because the estimate of the annual number of baseline fatalities comes from seven years of recent incident data that corroborate eleven prior years of incident data. OSHA's estimate of fatalities avoided is more sensitive because it is based on professional judgment after reviewing incident reports in the record. Moreover, OSHA believes that its benefit estimates have a tendency toward underestimation, as training and work practices adopted in an effort to comply with the final rule will likely increase the use of safety equipment and safer work techniques, thereby further reducing fatalities and injuries.⁹⁵

⁹⁵ OSHA notes that the literature on the effectiveness of training indicates positive benefits, but the extent of benefits varies depending on intervention methodology and other factors. See research by the National Institute for Occupational Safety and Health: Cohen and Colligan, 1998, and NIOSH, 2010 (<http://www.cdc.gov/niosh/docs/2010-127/pdfs/2010-127.pdf>).

The impacts exhibit below presents a summary of the annualized costs and benefits for each section of the final standard, assuming a discount rate of seven percent. In addition to estimating annualized costs using a discount rate of seven percent, OSHA, for sensitivity purposes, also used OIRA's recommended alternative discount rate of three percent. Under the alternative scenario of a three-percent discount rate, OSHA estimates that annualized costs would decline from \$305.0 million to \$297.0 million. For both this scenario and for the primary (seven-percent rate) scenario, OSHA assumed that employers will incur all costs (first-year and recurring) on implementation of the final standard. OSHA also is assuming that the benefits outlined in this section will accrue once the rule takes effect. Section D of this FEA (Benefits, Net Benefits, Cost Effectiveness, and Sensitivity Analysis) describes in detail the other cost-related uncertainties.

BILLING CODE 4510-29-P

Impacts Exhibit V-1: Estimated Annualized Costs and Benefits of the Final Rule

Requirement	Benefits			Costs (\$millions)
	Type of Accident Prevented	Fatalities Prevented	Injuries Prevented	
§1910.22 General Requirements	Fall on same level	0.7	1,371	\$33.2
	Fall from floor, dock, or ground level	1.4	399	
	Fall from building girders or other structural steel	Fraction of 0.4	Fraction of 13	
§1910.23 Ladders	Fall from ladder	Large fraction of 11.4	Large fraction of 2,161	\$11.3
	Fall from ship, boat, n.e.c.[a]	Fraction of 0.2	Large fraction of 415	
§1910.24 Step Bolts and Manhole Steps	Fall from ladder	Small fraction of 11.4	Small fraction of 2,161	\$18.0
	Fall down stairs or steps	1.0	736	
	Fall to lower level, n.e.c.	3.4	362	
§1910.27 Scaffolds	Fall from scaffold, staging	Large fraction of 5.4	Large fraction of 239	\$71.6
§1910.28 Duty to Have Fall Protection	Fall from ladder	Small fraction of 11.4	Small fraction of 2,161	\$55.9
	Fall from roof	Large fraction of 5.1	Large fraction of 86	
§1910.29 Fall Protection Systems Criteria and Practices	Fall from building girders or other structural steel	Fraction of 0.4	Fraction of 13	\$13.1
	Fall from ship, boat, n.e.c.	Fraction of 0.2	Fraction of 415	
	Fall from scaffold, staging	Small fraction of 5.4	Small fraction of 239	

**Impacts Exhibit V-1: Estimated Annualized Costs and Benefits of the Final Rule
(continued)**

Requirement	Benefits			Costs (\$millions)
	Type of Accident Prevented	Fatalities Prevented	Injuries Prevented	
§1910.30 Training Requirements	Multiple fall categories	Fraction of benefits for many fall categories	Fraction of benefits for many fall categories	\$74.2
§1910.132 General Requirements	Multiple fall categories affected by assessment of hazards associated with personal fall protection equipment	Fraction of benefits for many fall categories	Fraction of benefits for many fall categories	\$12.7
§1910.140 Fall Protection	Multiple fall categories affected by equipment design specifications	Fraction of benefits for many fall categories	Fraction of benefits for many fall categories	\$11.0
Rule Familiarization	Multiple fall categories	Fraction of benefits for many fall categories	Fraction of benefits for many fall categories	\$4.1
Total – Preferred Option		29	5,842	\$305.0
Less Stringent Alternative – Narrower Scope for Training Requirements		Lower Benefits than under Preferred Option		Lower Costs than under Preferred Option
More Stringent Alternative – Mandated Combination of Cages, Wells, Landing Platforms, and Ladder Safety Systems		Modestly Higher Benefits than under Preferred Option		Significantly Higher Costs (Possibly over \$1 Billion) than under Preferred Option

[a]n.e.c.: Not elsewhere classified; term used throughout this FEA.

Source: U.S. Department of Labor, OSHA, Directorate of Standards and Guidance, Office of Regulatory Analysis-Safety.

BILLING CODE 4510-29-C

b. Changes From OSHA's Preliminary Economic Analysis to This Final Analysis

As shown below in the summary table for Section B of this FEA (Assessing the Need for Regulation), OSHA projects that the final rule will produce annual benefits of 29 fatalities and 5,842 lost-workday injuries prevented, while annualized costs will total \$305.0 million. OSHA's preliminary estimate of benefits (in the Preliminary Economic Analysis (PEA) for the proposed rule) was 20 fatalities and 3,706 lost-workday injuries prevented, and the Agency's preliminary estimate of costs in the PEA totaled \$173.2 million. The later sections of this FEA explain the reasons for these changes in detail. To summarize, OSHA notes that the primary factors contributing to larger benefits and costs (in relation to the PEA) are: (1) Explicit requirements for ladder safety systems for fixed ladders and structures with step bolts, guardrails for slaughtering platforms, and roof anchor systems for rooftop operations; (2) additional time allotted for inspection of walking-working surfaces for dust and other hazardous substances, consistent with a clarification in the regulatory text; and (3) an increase in the number of workers in outdoor advertising and other activities who will need training in using fall protection equipment.

c. Alternative Regulatory Approaches

To determine the appropriate approach for addressing the occupational risks associated with slips, trips, and falls in general industry, OSHA considered many different factors and potential alternatives. The Agency examined the incidence of injuries and fatalities, and their direct and underlying causes, to ascertain revisions to the existing standards. OSHA reviewed these standards, assessed current practices in the industry, collected information and comments from experts, and scrutinized the available data and research.

OSHA faces several constraints in determining appropriate regulatory requirements. Under Section 3(8) of the OSH Act, OSHA standards must be "reasonably necessary or appropriate to provide safe or healthful employment and places of employment." Also, under Section 6(b)(8) of the OSH Act, to the extent an OSHA standard differs substantially from existing national consensus standards, the Agency must explain why the OSHA standard will better accomplish the purposes of the OSH Act. As noted elsewhere, OSHA

standards also must be technologically and economically feasible and cost effective, in the sense of the term as used in the OSH Act as interpreted by the courts.⁹⁶ Section IV, Summary and Explanation of the Final Rule, earlier in this preamble, provides a full discussion of the basis for the regulatory requirements in the final rule. The Final Regulatory Flexibility Screening Analysis later in this section of the preamble discusses the regulatory alternatives considered by OSHA. In that section, Table V-34 presents impacts associated with regulatory alternatives for selected provisions of the final standard. OMB's Circular A-4, *Regulatory Analysis*, recommends that agencies "should analyze at least three options: The preferred option; a more stringent option that achieves additional benefits (and presumably costs more) beyond those realized by the preferred option; and a less stringent option that costs less (and presumably generates fewer benefits) than the preferred option" (p. 16). This final rule presents the preferred option. The less stringent alternative, rejected by OSHA, would reduce the number of fall-hazard categories requiring training; however, the cost of this alternative would remain significant (but below the cost of \$74.2 million for the preferred alternative training requirements), with a reduction in benefits relative to the preferred alternative. OSHA did not explicitly quantify this alternative.

The more stringent alternative would require that employers provide cages, wells, landing platforms, and ladder safety devices for all fixed ladders; the cost of this alternative would be highly significant, while the incremental benefits would be modest relative to the preferred alternative. OSHA notes that the 1990 NPRM estimated the annualized cost for cages, wells, and other safety devices for fixed ladders to be \$1.6 billion in 1990 dollars. Evidence in the record suggests that cages and wells are an outdated technology that do not provide adequate fall protection for workers climbing ladders, and that ladder safety devices are a recent development that provide a feasible

⁹⁶ The OSHA Act as interpreted by the courts requires that regulations be cost effective in the sense that no other alternative in the record addressing the same hazards has an equivalent reduction in the risk associated with those hazards; that is, reduces those risks to the same extent at lower cost (*Am. Textile Mfrs. Inst. v. Donovan*, 453 U.S. 490, 514 n. 2 (1981); *UAW v. OSHA*, 37 F.3d 665, 668 (D.C. Cir. 1994)). This is not a wide ranging invitation to compare cost effectiveness across many risks but a narrow assurance that the exact same effects could not be achieved at less cost. An analysis of regulatory alternatives is provided in Section V.H.8.

alternative, or complement, to cages and wells (Exs. 113; 198). Therefore, if employers could not use such devices, the more stringent alternative requiring cages, wells, and landing platforms would be far more expensive than to the final rule.

B. Assessing the Need for Regulation

OSHA previously considered non-regulatory alternatives and established the need for regulation of walking-working surfaces when it promulgated the standard for fall protection in construction (59 FR 40672). The Agency asserts that the same need for regulation applies when employees in general industry are engaged in tasks on walking-working surfaces. Employees in general industry performing work on floors, other ground-level surfaces, or at heights are exposed to a variety of significant hazards—particularly slips, trips, and falls—that can and do cause serious injury and death. Although some of these incidents might have been prevented by better compliance with existing safety standards, research and analyses conducted by OSHA have found that many preventable injuries and fatalities could continue to occur even if employers fully complied with the existing standards. Relative to full compliance with the existing standards, OSHA estimates, in Section D of this FEA, that full compliance with the final standard would prevent an estimated additional 5,842 injuries and 29 fatalities annually.

Executive Order 12866 provides that "[e]ach agency shall identify the problem that it intends to address [via regulation] . . . including, where applicable, the failures of private markets." Executive Order 13563 reiterates that requirement. In the absence of regulations, market failures can prevent free markets from providing the levels of occupational safety—and particularly the levels of safety for workers affected by this standard—that would maximize net benefits to society.

In the absence of regulation, many employees would simply be unaware of the hazards that walking-working surfaces present or the procedures to follow to protect against such hazards. Even those employees with years of experience working at elevated or other surfaces may lack training on fall protection, information about specific fall hazards, or needed equipment for preventing or limiting the impact of falls.

The final standard for walking-working surfaces in general industry addresses these problems. The benefits analysis presented in Section D of this FEA shows that many accidents are

potentially preventable with better information on worksite conditions and the provision of the proper procedures and equipment for fall protection. In cases where employers do provide training on fall prevention, that training may be incomplete or ineffective in the absence of a specific set of requirements to train to. OSHA's analysis of benefits and costs, conducted with an orientation toward the OSH Act and associated case law, shows that the benefits of the final standard significantly exceed its costs.

To better understand the market failures that create the need for this rule, it is necessary to examine the economic incentives that underlie employer decisions with respect to workplace safety and health. An employee typically accepts the risks associated with a particular job in return for two forms of compensation—(1) a wage premium for assuming that risk, and (2) expected compensation for damages in the event of occupational injury or illness. The rational profit-maximizing employer will make investments in workplace safety to reduce the level of risk to employees only if such expenditures result in at least an offsetting reduction in the employer's payouts of wage premiums for risk and compensation for damages. To the extent that the sum of the costs of wage premiums and compensation for damages accurately represents the total damages associated with workplace accidents, the rational employer will accordingly arrive at the socially optimal level of accident prevention from an economic efficiency viewpoint.

Consequently, the major possible sources of market failure, resulting in an "under-provision" of health and safety, would be either: (1) The existence of occupational accident costs that are borne neither by the employee nor by the employer or (2) the wage premiums or compensation for damages are not fully responsive to changes in employer-specific workplace risk. Both cases apply here.

In the first case, there are some occupational injury and illness costs that are incurred by neither the employer nor the employee. For instance, neither of those two parties has a vested interest in Federal and State taxes that go unpaid as a result of an employee injury. Such taxes typically represent 15 percent (for Social Security alone) to 26 percent of the total value of the income loss to the employee (IRS, 2013; Urban Institute/

Brookings, 2012).⁹⁷ Tax losses are likely to be significant because (1) workers' compensation payments are not subject to Federal income or Social Security taxes (IRS, 2012), and (2) many studies have found that income losses not compensated by workers' compensation are significant (NASI, 2012). (There are some other possible incentive effects with respect to tax policy that might either encourage or discourage safety, but they represent a small percentage of the total value of a statistical life or injury by comparison.)

In the second case, as discussed below, the costs employers pay in compensation for damages or wage premiums are not fully responsive to changes in employer-specific workplace risk.

Most employers cover—and are required to cover—compensation for injured employees through workers' compensation insurance. (Some very large employers may self-insure in some states.) States highly regulate premiums for workers' compensation insurance and generally employ a combination of a class rating and an experience rating in deriving premiums (NCCI, 2013; Ashford, 2006). The class rating is based on the average risk for employees in the same occupations as those working for the employer. The basis of the experience rating is the employer's actual workers' compensation claims over the past several years. Very small firms are almost entirely class-rated; even medium-sized firms are partly class-rated; and it will take even firms that are fully experience-rated several years before their insurance premium levels fully reflect any change in their workplace safety performance.⁹⁸ As a result, most employers will not realize fully or promptly the gains from their expenditures to avoid workplace injury, illness, and fatality risks in the form of reduced workers' compensation premiums. The result is an insufficient level of worker protection from a societal perspective.

Furthermore, workers' compensation covers only a small fraction of most estimates of the willingness to pay to prevent a fatality.⁹⁹ Additionally,

⁹⁷ The average federal tax rate for 2009 for the middle quintile of household income was 11.1 percent (Urban Institute/Brookings, 2012).

⁹⁸ This outcome, of course, reflects an accounting point. Premiums due to class rating, by definition, do not change with an individual employer's injury experience. There is some empirical evidence, using a difference in differences methodology, that (small) firms that move from class to experience rating decrease their total claims by 8 to 12 percent (Neuhauser et al., 2013).

⁹⁹ While workers' compensation varies by state, Leigh and Marcin (2012) estimate that the average indemnity benefits for a fatality are \$225,919, far

workers' compensation payments do not fully compensate injuries in that workers' compensation provides no payments for pain and suffering or losses other than lost wages or medical expenses associated with injuries. There is extensive evidence that workers' compensation does not even fully restore wages lost as a result of long-term disability (Ashford, 2006).

Having to pay wage premiums for risk is another economic incentive for employers to mitigate occupational risk. However, wage premiums do not respond to changes in risk level very strongly, due to information asymmetries. For an employer to have an adequate incentive to implement measures that will prevent workplace accidents, it is not sufficient that employees simply know that their work is dangerous, or even know quantitatively that their occupation has a given risk. Employees must know the exact nature and likely quantitative effects of their employer's safety measures and systems; have a reasonable expectation that their employer will continue to provide existing safety measures in the future; and be able to act on their knowledge of risk by readily changing workplaces or changing wage demands in response to differences in levels of risk.¹⁰⁰ OSHA believes that even skilled workers exposed to the risks of slips, trips, and falls (including some persons injured in accidents preventable by the final rule who fall in that category) lack such detailed employer-specific knowledge or the ability to act on it. Further, employees who typically work at a variety of different sites, including sites controlled by multiple employers, will find it particularly challenging to determine future risk levels, as these levels will vary from site to site.

In summary, OSHA believes that: (1) The provisions of the final rule are necessary to assure that employees have the information, procedures, and equipment they need to protect themselves; (2) neither employers nor

less than willingness-to-pay estimates. For example, as explained in Section D of this FEA, OSHA uses a willingness-to-pay measure of \$8.4 million per life saved in 2010 dollars. Other agencies use different estimates, but all the values are in the millions of dollars.

¹⁰⁰ Furthermore, bargaining power differences or external constraints must not interfere in the wage setting process—as they do in circumstances of monopsony or multiemployer collective bargaining agreements, for example. Bargaining power differences may occur, for example, in small communities where a single manufacturer may be the employer for certain kinds of skills, or the more general issue that an employee's firm specific skills (such as understanding of unique processes or equipment) are in demand by only a single employer.

employees absorb the full costs of occupational injuries and fatalities; and (3) wage premiums and workers' compensation insurance are not sufficiently responsive to changes in risk to assure that employers will reduce risk to the socially optimal level. The rule is, therefore, necessary to address market failures that result from externalities and information asymmetries that lead to the provision of insufficient levels of worker safety.

C. Profile of Affected Industries, Firms, Workers, and Other Factors of Production

1. Introduction

This section presents OSHA's profile of the firms, establishments, and employees within the industries affected by OSHA's revision to 29 CFR part 1910, subparts D and I. The Agency based this profile on data assembled and organized by its contractor, Eastern Research Group (ERG, 2007), and updated using more recent data from the same data series used previously.

2. Affected Industries and Employees

Revised subparts D and I apply to employers and industries covered by OSHA's standards for general industry in 29 CFR part 1910. Similarly, all other subparts in part 1910 affected by these revisions to OSHA's walking-working surfaces standards would impose requirements on employers in general industry under OSHA's jurisdiction.¹⁰¹ The general industry category excludes establishments in the agriculture, construction, maritime (longshoring, marine terminal, and shipyards), and mining industries (except for oil and gas extraction). Also excluded from the final standard are employee tasks on surfaces that fall outside of OSHA's jurisdiction

¹⁰¹ For example, subpart F—Powered Platforms, Manlifts, and Vehicle-Mounted Work Platforms, would be affected by the revisions to subparts D and I. For a compilation of all standards affected by these revisions, see the Final Regulatory Text at the end of this document.

due to location or operational status, or those tasks that are subject to unique industry-specific fall protection requirements addressed elsewhere in part 1910, including § 1910.268, Telecommunications, and § 1910.269, Electric power generation, transmission, and distribution. An example of a jurisdictional category excluded from the scope of the final rule based on location or operational status is employee exposure to fall hazards when railroad rolling stock is traveling on rails or trucks are traveling on highways; the Department of Transportation regulates these operations.

The walking-working surfaces covered by the final standards are present in nearly every establishment. Therefore, OSHA assumes that the number of establishments and employees potentially affected by subpart D includes all establishments and employees in general industry. Table V-1 shows the total number of establishments and employees potentially affected by revisions to subpart D, with the data listed in order by the North American Industry Classification System (NAICS) 4-digit industry code (OMB, 2007). Relying on the U.S. Census' Statistics of U.S. Businesses for 2007, OSHA estimates that the final standard will affect 6.9 million establishments employing 112 million employees; the comparable figures in the PEA were 6.7 million establishments and 112 million employees, based on 2006 data. Table V-1 also provides economic profile statistics for the industries covered by the final standard.

For purposes of estimating training requirements with respect to ladders, OSHA estimated that these provisions would apply to the 5.2 million employees engaged in construction, installation, maintenance, repair, and moving operations in general industry. These employees represent the main group of workers affected by the final

standards; however, the final standards may affect employees doing other types of operations and some general industry employees engaged in installation, maintenance, and repair operations will not be affected. Therefore, to estimate the population affected, OSHA identified general industry employees in occupational codes involving construction, installation, maintenance and repair. There certainly are ladder users in other occupations, but the occupations OSHA has included also include many persons whose work typically would not involve the use of ladders (*e.g.*, computer repair, electronics repair, or construction work such as plumbing or carpet repair). As a result, while the OSHA list of occupations examined for purposes of costing ladder training may not include all possible persons receiving such training, it is balanced by the inclusion of some occupations that will not need training. This approach assumes that employees in construction occupations, but employed by general industry employers rather than construction employers, routinely engage in what OSHA labels as maintenance (*i.e.*, a general industry activity) rather than construction activities.

In the PEA, OSHA used Census¹⁰² data on payroll and receipts to estimate average revenue per establishment in 2006 for each 4-digit NAICS industry. For this FEA, revenue data for 2007 were available from Census's *Statistics of U.S. Businesses*; Table V-1 reports these revenue data as average receipts per establishment by 4-digit NAICS industry in Table V-1.¹⁰³

BILLING CODE 4510-29-P

¹⁰² "Census" refers to the U.S. Census Bureau.

¹⁰³ At the time the Agency was developing this FEA, the most recent year for detailed industry-specific revenue was 2007 Statistics of US Businesses. In the years since that date the US economy has experienced a recession and a recovery. Because new hires were greater in 2007, this had the effect of increasing costs.

Table V-1
Profile of General Industry Establishments Covered by the Final Standard for Subparts D and I

NAICS	NAICS Description	Establishments	Average Receipts per Establishment (\$1,000)[a]	Total Employees	Production Employees		
					Total No. of Production Employees[b]	Production Employees in At-Risk Occupations (Construction, Installation, Maintenance, and Repair Occupations)[c]	
						Number	Share of Production Employees
1131	Timber Tract Operations	450	\$1,669	2,632	NA[d]	NA	NA
1132	Forest Nurseries and Gathering of Forest Products	231	\$1,522	2,216	NA	NA	NA
1133	Logging	9,810	\$1,086	59,597	16,250	2,580	15.9%
1141	Fishing	2,062	\$1,161	5,302	NA	NA	NA
1142	Hunting and Trapping	327	\$688	1,845	NA	NA	NA
1153	Support Activities for Forestry	1,755	\$819	13,740	NA	NA	NA
2111	Oil and Gas Extraction	7,542	\$31,038	141,809	51,040	24,910	48.8%
2211	Electric Power Generation, Transmission and Distribution	9,611	\$45,816	503,134	192,210	130,970	68.1%
2212	Natural Gas Distribution	2,283	\$54,187	79,354	47,610	32,520	68.3%
2213	Water, Sewage and Other Systems	4,780	\$2,033	40,269	27,410	10,760	39.3%
3111	Animal Food Manufacturing	1,817	\$21,156	46,983	36,000	3,580	9.9%
3112	Grain and Oilseed Milling	830	\$87,089	58,049	42,600	5,380	12.6%

**Table V-1
Profile of General Industry Establishments Covered by the Final Standard for Subparts D and I (continued)**

NAICS	NAICS Description	Establishments	Average Receipts per Establishment (\$1,000)[a]	Total Employees	Production Employees		
					Total No. of Production Employees[b]	Production Employees in At-Risk Occupations (Construction, Installation, Maintenance, and Repair Occupations)[c]	
						Number	Share of Production Employees
3113	Sugar and Confectionery Product Manufacturing	1,788	\$15,751	73,457	55,980	6,510	11.6%
3114	Fruit and Vegetable Preserving and Specialty Food Manufacturing	1,668	\$38,180	162,253	138,180	15,690	11.4%
3115	Dairy Product Manufacturing	1,612	\$55,897	129,692	98,900	9,660	9.8%
3116	Animal Slaughtering and Processing	3,817	\$40,958	487,813	464,910	25,900	5.6%
3117	Seafood Product Preparation and Packaging	685	\$16,865	33,169	28,540	1,500	5.3%
3118	Bakeries and Tortilla Manufacturing	10,269	\$5,472	284,998	204,000	11,840	5.8%
3119	Other Food Manufacturing	3,310	\$22,381	162,852	111,360	9,490	8.5%
3121	Beverage Manufacturing	3,960	\$22,088	135,979	107,700	15,210	14.1%
3122	Tobacco Manufacturing	109	\$384,255	20,135	17,780	3,710	20.9%
3131	Fiber, Yarn, and Thread Mills	424	\$21,211	42,041	40,060	5,950	14.9%
3132	Fabric Mills	1,318	\$14,424	80,514	64,710	7,390	11.4%
3133	Textile and Fabric Finishing and Fabric Coating Mills	1,350	\$6,381	41,527	38,820	2,550	6.6%
3141	Textile Furnishings Mills	2,583	\$7,733	80,278	68,110	4,850	7.1%

Table V-1
Profile of General Industry Establishments Covered by the Final Standard for Subparts D and I (continued)

NAICS	NAICS Description	Establishments	Average Receipts per Establishment (\$1,000)[a]	Total Employees	Production Employees		
					Total No. of Production Employees[b]	Production Employees in At-Risk Occupations (Construction, Installation, Maintenance, and Repair Occupations)[c]	
						Number	Share of Production Employees
3149	Other Textile Product Mills	4,149	\$2,612	72,700	54,280	3,170	5.8%
3151	Apparel Knitting Mills	487	\$7,915	26,584	25,130	2,250	9.0%
3152	Cut and Sew Apparel Manufacturing	8,965	\$2,603	155,742	135,500	1,463	1.1%
3159	Apparel Accessories and Other Apparel Manufacturing	916	\$1,890	15,128	13,830	340	2.5%
3161	Leather and Hide Tanning and Finishing	244	\$5,655	4,856	4,440	264	5.9%
3162	Footwear Manufacturing	306	\$6,905	15,017	13,070	360	2.8%
3169	Other Leather and Allied Product Manufacturing	842	\$3,188	16,798	9,960	100	1.0%
3211	Sawmills and Wood Preservation	4,168	\$6,928	112,425	91,820	9,160	10.0%
3212	Veneer, Plywood, and Engineered Wood Product Manufacturing	1,924	\$11,371	109,002	94,280	12,260	13.0%
3219	Other Wood Product Manufacturing	10,530	\$4,759	306,138	249,800	39,970	16.0%
3221	Pulp, Paper, and Paperboard Mills	551	\$149,010	130,068	105,270	22,220	21.1%
3222	Converted Paper Product Manufacturing	4,486	\$21,433	295,028	257,680	20,140	7.8%
3231	Printing and Related Support Activities	33,281	\$3,054	631,771	397,300	10,140	2.6%

**Table V-1
Profile of General Industry Establishments Covered by the Final Standard for Subparts D and I (continued)**

NAICS	NAICS Description	Establishments	Average Receipts per Establishment (\$1,000)[a]	Total Employees	Production Employees		
					Total No. of Production Employees[b]	Production Employees in At-Risk Occupations (Construction, Installation, Maintenance, and Repair Occupations)[c]	
						Number	Share of Production Employees
3241	Petroleum and Coal Products Manufacturing	2,408	\$247,193	103,577	74,770	17,330	23.2%
3251	Basic Chemical Manufacturing	2,540	\$88,423	165,025	93,150	19,100	20.5%
3252	Resin, Synthetic Rubber, and Artificial Synthetic Fibers and Filaments Manufacturing	1,076	\$97,133	88,601	72,460	13,690	18.9%
3253	Pesticide, Fertilizer, and Other Agricultural Chemical Manufacturing	906	\$31,547	28,618	24,350	4,520	18.6%
3254	Pharmaceutical and Medicine Manufacturing	1,926	\$94,046	241,339	111,800	14,170	12.7%
3255	Paint, Coating, and Adhesive Manufacturing	1,906	\$17,179	62,493	37,360	2,710	7.3%
3256	Soap, Cleaning Compound, and Toilet Preparation Manufacturing	2,241	\$41,957	104,422	69,760	7,580	10.9%
3259	Other Chemical Product and Preparation Manufacturing	2,800	\$16,028	103,219	64,520	6,770	10.5%
3261	Plastics Product Manufacturing	12,054	\$14,344	707,972	484,610	34,130	7.0%
3262	Rubber Product Manufacturing	2,179	\$17,848	147,511	120,650	9,440	7.8%

Table V-1
Profile of General Industry Establishments Covered by the Final Standard for Subparts D and I (continued)

NAICS	NAICS Description	Establishments	Average Receipts per Establishment (\$1,000)[a]	Total Employees	Production Employees		
					Total No. of Production Employees[b]	Production Employees in At-Risk Occupations (Construction, Installation, Maintenance, and Repair Occupations)[c]	
						Number	Share of Production Employees
3271	Clay Product and Refractory Manufacturing	1,560	\$5,818	52,544	44,040	4,350	9.9%
3272	Glass and Glass Product Manufacturing	2,102	\$11,056	97,876	81,800	8,960	11.0%
3273	Cement and Concrete Product Manufacturing	9,963	\$6,645	221,488	203,410	35,960	17.7%
3274	Lime and Gypsum Product Manufacturing	362	\$21,293	17,332	15,330	3,160	20.6%
3279	Other Nonmetallic Mineral Product Manufacturing	3,485	\$5,983	82,888	65,810	11,150	16.9%
3311	Iron and Steel Mills and Ferroalloy Manufacturing	901	\$116,393	109,998	81,680	19,330	23.7%
3312	Steel Product Manufacturing from Purchased Steel	699	\$30,504	44,492	47,060	5,290	11.2%
3313	Alumina and Aluminum Production and Processing	612	\$67,170	63,988	59,590	10,870	18.2%
3314	Nonferrous Metal (except Aluminum) Production and Processing	938	\$58,260	60,466	51,800	6,990	13.5%
3315	Foundries	2,117	\$16,145	159,977	133,200	13,590	10.2%
3321	Forging and Stamping	2,664	\$12,189	124,406	86,660	6,800	7.8%
3322	Cutlery and Handtool Manufacturing	1,485	\$7,449	50,529	37,250	2,170	5.8%

**Table V-1
Profile of General Industry Establishments Covered by the Final Standard for Subparts D and I (continued)**

NAICS	NAICS Description	Establishments	Average Receipts per Establishment (\$1,000)[a]	Total Employees	Production Employees		
					Total No. of Production Employees[b]	Production Employees in At-Risk Occupations (Construction, Installation, Maintenance, and Repair Occupations)[c]	
						Number	Share of Production Employees
3323	Architectural and Structural Metals Manufacturing	13,705	\$6,500	398,786	312,940	38,720	12.4%
3324	Boiler, Tank, and Shipping Container Manufacturing	1,570	\$20,031	93,356	68,060	6,200	9.1%
3325	Hardware Manufacturing	795	\$12,314	41,763	23,970	1,180	4.9%
3326	Spring and Wire Product Manufacturing	1,614	\$6,349	53,413	43,030	2,470	5.7%
3327	Machine Shops; Turned Product; and Screw, Nut, and Bolt Manufacturing	25,267	\$2,424	395,207	280,200	10,560	3.8%
3328	Coating, Engraving, Heat Treating, and Allied Activities	6,162	\$4,308	137,183	117,980	6,310	5.3%
3329	Other Fabricated Metal Product Manufacturing	6,375	\$10,709	271,223	192,570	11,580	6.0%
3331	Agriculture, Construction, and Mining Machinery Manufacturing	3,064	\$28,804	205,545	160,220	11,870	7.4%
3332	Industrial Machinery Manufacturing	3,845	\$10,320	130,022	63,620	5,910	9.3%
3333	Commercial and Service Industry Machinery Manufacturing	2,296	\$10,796	95,729	54,370	4,980	9.2%

Table V-1
Profile of General Industry Establishments Covered by the Final Standard for Subparts D and I (continued)

NAICS	NAICS Description	Establishments	Average Receipts per Establishment (\$1,000)[a]	Total Employees	Production Employees		
					Total No. of Production Employees[b]	Production Employees in At-Risk Occupations (Construction, Installation, Maintenance, and Repair Occupations)[c]	
						Number	Share of Production Employees
3334	Ventilation, Heating, Air-Conditioning, and Commercial Refrigeration Equipment Manufacturing	1,822	\$22,423	151,175	115,510	13,270	11.5%
3335	Metalworking Machinery Manufacturing	8,010	\$3,631	167,558	139,940	5,180	3.7%
3336	Engine, Turbine, and Power Transmission Equipment Manufacturing	930	\$45,616	102,482	69,130	6,330	9.2%
3339	Other General Purpose Machinery Manufacturing	6,231	\$13,746	285,029	172,550	16,160	9.4%
3341	Computer and Peripheral Equipment Manufacturing	1,298	\$50,267	99,137	30,390	3,720	12.2%
3342	Communications Equipment Manufacturing	1,828	\$35,437	151,847	42,640	5,650	13.3%
3343	Audio and Video Equipment Manufacturing	530	\$14,503	17,191	13,180	990	7.5%
3344	Semiconductor and Other Electronic Component Manufacturing	4,753	\$25,667	362,859	214,750	13,070	6.1%
3345	Navigational, Measuring, Electromedical, and Control Instruments Manufacturing	5,265	\$25,181	384,966	142,990	13,920	9.7%
3346	Manufacturing and Reproducing Magnetic and Optical Media	804	\$7,705	27,288	19,090	1,520	8.0%

**Table V-1
Profile of General Industry Establishments Covered by the Final Standard for Subparts D and I (continued)**

NAICS	NAICS Description	Establishments	Average Receipts per Establishment (\$1,000)[a]	Total Employees	Production Employees		
					Total No. of Production Employees[b]	Production Employees in At-Risk Occupations (Construction, Installation, Maintenance, and Repair Occupations)[c]	
						Number	Share of Production Employees
3351	Electric Lighting Equipment Manufacturing	1,223	\$11,500	57,515	40,520	2,520	6.2%
3352	Household Appliance Manufacturing	350	\$68,995	65,666	55,620	3,050	5.5%
3353	Electrical Equipment Manufacturing	2,407	\$17,529	138,332	91,165	6,374	7.0%
3359	Other Electrical Equipment and Component Manufacturing	2,164	\$23,393	144,746	95,620	6,800	7.1%
3361	Motor Vehicle Manufacturing	378	\$683,671	196,493	174,525	21,551	12.3%
3362	Motor Vehicle Body and Trailer Manufacturing	2,187	\$16,182	151,588	142,240	11,080	7.8%
3363	Motor Vehicle Parts Manufacturing	5,526	\$36,411	593,630	490,500	50,450	10.3%
3364	Aerospace Product and Parts Manufacturing	1,725	\$99,787	408,139	204,890	50,350	24.6%
3365	Railroad Rolling Stock Manufacturing	221	\$58,054	28,712	20,000	3,490	17.5%
3366	Ship and Boat Building	1,771	\$16,101	148,864	115,720	31,360	27.1%
3369	Other Transportation Equipment Manufacturing	1,049	\$20,370	46,721	30,350	2,690	8.9%
3371	Household and Institutional Furniture and Kitchen Cabinet Manufacturing	16,566	\$2,875	333,974	291,910	23,650	8.1%

Table V-1
Profile of General Industry Establishments Covered by the Final Standard for Subparts D and I (continued)

NAICS	NAICS Description	Establishments	Average Receipts per Establishment (\$1,000)[a]	Total Employees	Production Employees		
					Total No. of Production Employees[b]	Production Employees in At-Risk Occupations (Construction, Installation, Maintenance, and Repair Occupations)[c]	
						Number	Share of Production Employees
3372	Office Furniture (including Fixtures) Manufacturing	4,115	\$6,637	141,000	99,860	6,980	7.0%
3379	Other Furniture Related Product Manufacturing	1,036	\$9,739	42,427	35,850	1,650	4.6%
3391	Medical Equipment and Supplies Manufacturing	12,194	\$6,578	316,789	191,430	7,210	3.8%
3399	Other Miscellaneous Manufacturing	18,966	\$3,825	364,059	221,800	15,530	7.0%
4231	Motor Vehicle and Motor Vehicle Parts and Supplies Merchant Wholesalers	24,535	\$23,333	355,828	154,330	50,180	32.5%
4232	Furniture and Home Furnishing Merchant Wholesalers	12,670	\$6,231	153,866	38,080	3,320	8.7%
4233	Lumber and Other Construction Materials Merchant Wholesalers	19,633	\$8,055	264,252	130,910	14,470	11.1%
4234	Professional and Commercial Equipment and Supplies Merchant Wholesalers	36,115	\$12,095	705,551	138,430	71,910	51.9%
4235	Metal and Mineral (except Petroleum) Merchant Wholesalers	10,660	\$19,824	160,366	65,070	3,670	5.6%

**Table V-1
Profile of General Industry Establishments Covered by the Final Standard for Subparts D and I (continued)**

NAICS	NAICS Description	Establishments	Average Receipts per Establishment (\$1,000)[a]	Total Employees	Production Employees		
					Total No. of Production Employees[b]	Production Employees in At-Risk Occupations (Construction, Installation, Maintenance, and Repair Occupations)[c]	
						Number	Share of Production Employees
4236	Electrical and Electronic Goods Merchant Wholesalers	29,379	\$14,085	449,905	73,200	25,160	34.4%
4237	Hardware, and Plumbing and Heating Equipment and Supplies Merchant Wholesalers	20,104	\$6,009	232,006	71,570	17,670	24.7%
4238	Machinery, Equipment, and Supplies Merchant Wholesalers	59,745	\$7,120	723,802	244,480	135,590	55.5%
4239	Miscellaneous Durable Goods Merchant Wholesalers	34,498	\$6,872	349,701	123,540	13,550	11.0%
4241	Paper and Paper Product Merchant Wholesalers	11,448	\$11,244	172,308	43,570	1,920	4.4%
4242	Drugs and Druggists' Sundries Merchant Wholesalers	7,649	\$67,598	248,057	30,770	1,600	5.2%
4243	Apparel, Piece Goods, and Notions Merchant Wholesalers	16,218	\$8,223	196,601	39,930	490	1.2%
4244	Grocery and Related Product Wholesalers	33,620	\$19,115	768,342	371,100	17,420	4.7%
4245	Farm Product Raw Material Merchant Wholesalers	6,566	\$20,313	61,349	31,270	1,720	5.5%

Table V-1
Profile of General Industry Establishments Covered by the Final Standard for Subparts D and I (continued)

NAICS	NAICS Description	Establishments	Average Receipts per Establishment (\$1,000)[a]	Total Employees	Production Employees		
					Total No. of Production Employees[b]	Production Employees in At-Risk Occupations (Construction, Installation, Maintenance, and Repair Occupations)[c]	
						Number	Share of Production Employees
4246	Chemical and Allied Products Merchant Wholesalers	12,541	\$13,083	139,481	50,910	6,020	11.8%
4247	Petroleum and Petroleum Products Merchant Wholesalers	7,024	\$90,012	94,845	48,370	6,050	12.5%
4248	Beer, Wine, and Distilled Alcoholic Beverage Merchant Wholesalers	4,160	\$26,590	178,694	61,690	1,870	3.0%
4249	Miscellaneous Nondurable Goods Merchant Wholesalers	31,414	\$8,472	368,372	127,530	5,970	4.7%
4251	Wholesale Electronic Markets and Agents and Brokers	56,485	\$10,679	341,524	147,960	30,340	20.5%
4411	Automobile Dealers	51,236	\$14,689	1,273,660	496,270	317,590	64.0%
4412	Other Motor Vehicle Dealers	17,030	\$3,746	168,973	66,040	51,820	78.5%
4413	Automotive Parts, Accessories, and Tire Stores	59,065	\$1,353	495,633	222,240	157,250	70.8%
4421	Furniture Stores	29,239	\$2,038	271,675	76,570	4,160	5.4%
4422	Home Furnishings Stores	36,246	\$1,452	324,863	54,250	26,010	47.9%
4431	Electronics and Appliance Stores	52,470	\$2,212	500,780	96,500	68,970	71.5%

**Table V-1
Profile of General Industry Establishments Covered by the Final Standard for Subparts D and I (continued)**

NAICS	NAICS Description	Establishments	Average Receipts per Establishment (\$1,000)[a]	Total Employees	Production Employees		
					Total No. of Production Employees[b]	Production Employees in At-Risk Occupations (Construction, Installation, Maintenance, and Repair Occupations)[c]	
						Number	Share of Production Employees
4441	Building Material and Supplies Dealers	67,949	\$4,282	1,202,392	244,830	46,280	18.9%
4442	Lawn and Garden Equipment and Supplies Stores	20,355	\$2,060	171,569	49,020	16,250	33.1%
4451	Grocery Stores	92,315	\$5,368	2,564,533	444,380	3,590	0.8%
4452	Specialty Food Stores	28,281	\$738	174,558	59,220	1,510	2.5%
4453	Beer, Wine, and Liquor Stores	30,435	\$1,181	142,692	6,700	160	2.4%
4461	Health and Personal Care Stores	89,406	\$2,898	1,069,187	53,350	3,760	7.0%
4471	Gasoline Stations	115,533	\$3,812	888,705	92,920	33,040	35.6%
4481	Clothing Stores	99,325	\$1,615	1,278,939	35,380	820	2.3%
4482	Shoe Stores	27,213	\$976	206,338	1,760	0	0.0%
4483	Jewelry, Luggage, and Leather Goods Stores	28,833	\$1,103	162,880	15,920	1,690	10.6%
4511	Sporting Goods, Hobby, and Musical Instrument Stores	43,522	\$1,453	455,576	38,720	17,950	46.4%
4512	Book, Periodical, and Music Stores	16,623	\$1,663	184,118	3,370	200	5.9%
4521	Department Stores	10,116	\$28,241	1,619,833	127,280	14,480	11.4%
4529	Other General Merchandise Stores	37,340	\$8,240	1,277,639	188,410	24,990	13.3%
4531	Florists	19,759	\$327	93,779	19,120	190	1.0%

Table V-1
Profile of General Industry Establishments Covered by the Final Standard for Subparts D and I (continued)

NAICS	NAICS Description	Establishments	Average Receipts per Establishment (\$1,000)[a]	Total Employees	Production Employees		
					Total No. of Production Employees[b]	Production Employees in At-Risk Occupations (Construction, Installation, Maintenance, and Repair Occupations)[c]	
						Number	Share of Production Employees
4532	Office Supplies, Stationery, and Gift Stores	40,674	\$1,102	315,159	28,970	12,810	44.2%
4533	Used Merchandise Stores	17,733	\$549	133,918	16,150	1,090	6.7%
4539	Other Miscellaneous Store Retailers	45,208	\$1,153	270,971	41,930	16,920	40.4%
4541	Electronic Shopping and Mail-Order Houses	16,670	\$10,146	268,328	33,930	2,460	7.3%
4542	Vending Machine Operators	5,158	\$1,445	49,446	29,110	15,870	54.5%
4543	Direct Selling Establishments	25,895	\$2,470	193,784	76,550	22,820	29.8%
4811	Scheduled Air Transportation	3,084	\$41,157	435,853	142,390	38,230	26.8%
4812	Nonscheduled Air Transportation	2,646	\$5,640	44,795	27,270	7,930	29.1%
4831	Deep Sea, Coastal, and Great Lakes Water Transportation	1,255	\$22,924	48,180	22,190	450	2.0%
4832	Inland Water Transportation	673	\$8,950	20,767	19,130	540	2.8%
4841	General Freight Trucking	68,494	\$2,165	998,697	839,850	48,700	5.8%
4842	Specialized Freight Trucking	52,925	\$1,396	477,700	347,130	24,240	7.0%
4851	Urban Transit Systems	932	\$3,403	52,912	34,260	4,150	12.1%

**Table V-1
Profile of General Industry Establishments Covered by the Final Standard for Subparts D and I (continued)**

NAICS	NAICS Description	Establishments	Average Receipts per Establishment (\$1,000)[a]	Total Employees	Production Employees		
					Total No. of Production Employees[b]	Production Employees in At-Risk Occupations (Construction, Installation, Maintenance, and Repair Occupations)[c]	
						Number	Share of Production Employees
4852	Interurban and Rural Bus Transportation	508	\$3,261	17,432	12,770	1,640	12.8%
4853	Taxi and Limousine Service	7,493	\$788	72,504	51,760	1,610	3.1%
4854	School and Employee Bus Transportation	4,673	\$2,191	206,787	164,010	6,700	4.1%
4855	Charter Bus Industry	1,247	\$1,762	28,384	25,690	1,830	7.1%
4859	Other Transit and Ground Passenger Transportation	3,469	\$1,104	62,604	53,240	1,530	2.9%
4861	Pipeline Transportation of Crude Oil	374	\$15,628	8,347	4,330	1,510	34.9%
4862	Pipeline Transportation of Natural Gas	1,479	\$14,061	24,683	13,690	5,220	38.1%
4869	Other Pipeline Transportation	922	\$8,320	9,415	4,170	1,000	24.0%
4871	Scenic and Sightseeing Transportation, Land	698	\$1,295	9,690	5,050	360	7.1%
4872	Scenic and Sightseeing Transportation, Water	1,880	\$756	15,612	6,460	250	3.9%
4879	Scenic and Sightseeing Transportation, Other	203	\$1,935	2,162	1,160	280	24.1%
4881	Support Activities for Air Transportation	5,430	\$3,678	3,676	98,340	47,000	47.8%
4882	Support Activities for Rail Transportation	1,018	\$3,282	308	20,480	7,660	37.4%

Table V-1
Profile of General Industry Establishments Covered by the Final Standard for Subparts D and I (continued)

NAICS	NAICS Description	Establishments	Average Receipts per Establishment (\$1,000)[a]	Total Employees	Production Employees		
					Total No. of Production Employees[b]	Production Employees in At-Risk Occupations (Construction, Installation, Maintenance, and Repair Occupations)[c]	
						Number	Share of Production Employees
4883	Support Activities for Water Transportation	2,330	\$7,072	1,442	79,680	5,950	7.5%
4884	Support Activities for Road Transportation	10,178	\$699	9,719	59,440	4,620	7.8%
4885	Freight Transportation Arrangement	17,903	\$2,304	212,165	40,240	1,820	4.5%
4889	Other Support Activities for Transportation	1,707	\$3,902	34,654	20,380	930	4.6%
4921	Couriers	9,116	\$8,233.28	528,177	398,690	13,900	3.5%
4922	Local Messengers and Local Delivery	4,729	\$877.68	41,013	18,050	220	1.2%
4931	Warehousing and Storage	14,440	\$2,766.70	679,077	434,980	21,630	5.0%
5111	Newspaper, Periodical, Book, and Directory Publishers	23,082	\$6,341.52	688,034	133,230	5,780	4.3%
5112	Software Publishers	8,426	\$14,921.54	346,675	3,730	1,780	47.7%
5121	Motion Picture and Video Industries	21,118	\$3,770.90	298,598	13,830	2,900	21.0%
5122	Sound Recording Industries	3,765	\$3,436.51	22,049	810	150	18.5%
5151	Radio and Television Broadcasting	9,757	\$5,673.89	252,294	4,420	2,860	64.7%
5152	Cable and Other Subscription Programming	658	\$63,287.42	41,674	22,490	21,960	97.6%

**Table V-1
Profile of General Industry Establishments Covered by the Final Standard for Subparts D and I (continued)**

NAICS	NAICS Description	Establishments	Average Receipts per Establishment (\$1,000)[a]	Total Employees	Production Employees		
					Total No. of Production Employees[b]	Production Employees in At-Risk Occupations (Construction, Installation, Maintenance, and Repair Occupations)[c]	
						Number	Share of Production Employees
5161	Internet Publishing and Broadcasting	2,746	\$4,317.76	46,627	280	80	28.6%
5171	Wired Telecommunications Carriers	27,445	\$6,677.53	621,712	167,800	165,500	98.6%
5172	Wireless Telecommunications Carriers (except Satellite)	11,817	\$14,132.48	277,622	11,720	11,410	97.4%
5173	Telecommunications Resellers	3,417	\$4,228.61	34,973	30,000	29,620	98.7%
5174	Satellite Telecommunications	708	\$8,810.15	13,149	2,660	2,660	100.0%
5175	Cable and Other Program Distribution	5,326	\$19,054.52	240,038	50,700	48,890	96.4%
5179	Other Telecommunications	1,365	\$3,116.63	14,428	1,510	1,510	100.0%
5181	Internet Service Providers and Web Search Portals	4,260	\$7,432.83	71,307	2,100	2,050	97.6%
5182	Data Processing, Hosting, and Related Services	15,662	\$4,566.21	375,474	9,020	3,520	39.0%
5191	Other Information Services	4,227	\$1,719.25	54,659	2,830	460	16.3%
5211	Monetary Authorities - Central Bank	104	\$447,246.12	20,223	680	500	73.5%

Table V-1
Profile of General Industry Establishments Covered by the Final Standard for Subparts D and I (continued)

NAICS	NAICS Description	Establishments	Average Receipts per Establishment (\$1,000)[a]	Total Employees	Production Employees		
					Total No. of Production Employees[b]	Production Employees in At-Risk Occupations (Construction, Installation, Maintenance, and Repair Occupations)[c]	
						Number	Share of Production Employees
5221	Depository Credit Intermediation	127,180	\$6,151.85	2,137,764	10,890	3,500	32.1%
5222	Nondepository Credit Intermediation	58,786	\$8,390.54	747,414	3,470	1,320	38.0%
5223	Activities Related to Credit Intermediation	46,750	\$1,436.05	341,041	1,660	880	53.0%
5231	Securities and Commodity Contracts Intermediation and Brokerage	39,749	\$10,955.04	528,722	1,280	640	50.0%
5232	Securities and Commodity Exchanges	392	\$11,418	8,600	250	40	16.0%
5239	Other Financial Investment Activities	49,924	\$4,369.98	404,402	3,200	1,370	42.8%
5241	Insurance Carriers	33,598	\$43,422.74	1,423,578	7,950	3,700	46.5%
5242	Agencies, Brokerages, and Other Insurance Related Activities	147,930	\$1,152.22	903,366	3,770	1,270	33.7%
5259	Other Investment Pools and Funds	3,678	\$7,005	33,396	1,920	770	40.1%
5311	Lessors of Real Estate	115,270	\$1,233	539,169	248,410	155,760	62.7%
5312	Offices of Real Estate Agents and Brokers	111,028	\$825	367,125	41,580	23,850	57.4%
5313	Activities Related to Real Estate	86,226	\$940	647,869	161,840	98,000	60.6%

Table V-1
Profile of General Industry Establishments Covered by the Final Standard for Subparts D and I (continued)

NAICS	NAICS Description	Establishments	Average Receipts per Establishment (\$1,000)[a]	Total Employees	Production Employees		
					Total No. of Production Employees[b]	Production Employees in At-Risk Occupations (Construction, Installation, Maintenance, and Repair Occupations)[c]	
						Number	Share of Production Employees
5321	Automotive Equipment Rental and Leasing	13,475	\$3,354	199,872	93,580	25,910	27.7%
5322	Consumer Goods Rental	31,338	\$752	237,074	40,220	7,370	18.3%
5323	General Rental Centers	5,435	\$987	35,493	25,220	8,920	35.4%
5324	Commercial and Industrial Machinery and Equipment Rental and Leasing	14,798	\$3,384	165,838	57,990	32,270	55.6%
5331	Lessors of Nonfinancial Intangible Assets (except Copyrighted Works)	2,568	\$8,804	31,735	1,700	250	14.7%
5411	Legal Services	191,351	\$1,263	1,206,577	5,070	580	11.4%
5412	Accounting, Tax Preparation, Bookkeeping, and Payroll Services	123,415	\$962	1,357,368	18,010	5,310	29.5%
5413	Architectural, Engineering, and Related Services	117,115	\$2,186	1,434,803	120,660	60,330	50.0%
5414	Specialized Design Services	34,783	\$693	134,739	20,340	2,390	11.8%
5415	Computer Systems Design and Related Services	116,769	\$2,347	1,297,710	30,580	22,640	74.0%

Table V-1
Profile of General Industry Establishments Covered by the Final Standard for Subparts D and I (continued)

NAICS	NAICS Description	Establishments	Average Receipts per Establishment (\$1,000)[a]	Total Employees	Production Employees		
					Total No. of Production Employees[b]	Production Employees in At-Risk Occupations (Construction, Installation, Maintenance, and Repair Occupations)[c]	
						Number	Share of Production Employees
5416	Management, Scientific, and Technical Consulting Services	151,766	\$1,277	1,015,109	57,950	24,420	42.1%
5417	Scientific Research and Development Services	17,787	\$6,372	688,052	30,300	11,360	37.5%
5418	Advertising and Related Services	40,275	\$2,066	445,590	43,730	8,000	18.3%
5419	Other Professional, Scientific, and Technical Services	74,295	\$873	599,993	23,470	3,830	16.3%
5511	Management of Companies and Enterprises	50,643	\$10,031	3,121,402	171,840	55,500	32.3%
5611	Office Administrative Services	29,996	\$2,184	472,690	31,760	10,840	34.1%
5612	Facilities Support Services	4,593	\$4,664	189,275	42,480	16,330	38.4%
5613	Employment Services	44,476	\$4,382	5,131,446	1,781,420	261,030	14.7%
5614	Business Support Services	35,543	\$1,739	766,237	30,920	3,890	12.6%
5615	Travel Arrangement and Reservation Services	22,312	\$1,876	243,943	8,790	1,270	14.4%
5616	Investigation and Security Services	25,223	\$1,677	777,680	67,570	56,050	83.0%
5617	Services to Buildings and Dwellings	179,825	\$598	1,722,595	1,664,320	59,570	3.6%

Table V-1
Profile of General Industry Establishments Covered by the Final Standard for Subparts D and I (continued)

NAICS	NAICS Description	Establishments	Average Receipts per Establishment (\$1,000)[a]	Total Employees	Production Employees		
					Total No. of Production Employees[b]	Production Employees in At-Risk Occupations (Construction, Installation, Maintenance, and Repair Occupations)[c]	
						Number	Share of Production Employees
5619	Other Support Services	21,075	\$1,881	324,602	108,800	19,230	17.7%
5621	Waste Collection	9,857	\$3,975	185,047	110,500	12,720	11.5%
5622	Waste Treatment and Disposal	2,729	\$5,199	56,755	69,650	18,240	26.2%
5629	Remediation and Other Waste Management Services	8,872	\$1,989	113,391	83,210	58,560	70.4%
6111	Elementary and Secondary Schools	21,066	\$2,943	827,165	766,170	100,280	13.1%
6112	Junior Colleges	862	\$8,099	80,568	40,630	12,020	29.6%
6113	Colleges, Universities, and Professional Schools	4,022	\$41,214	1,572,333	202,660	69,670	34.4%
6114	Business Schools and Computer and Management Training	7,640	\$1,243	65,818	1,770	510	28.8%
6115	Technical and Trade Schools	8,019	\$1,598	119,020	11,200	3,780	33.8%
6116	Other Schools and Instruction	38,506	\$430	302,908	4,920	1,570	31.9%
6117	Educational Support Services	6,781	\$1,574	71,573	1,900	470	24.7%
6211	Offices of Physicians	219,986	\$1,579	2,169,682	22,650	3,150	13.9%
6212	Offices of Dentists	126,392	\$742	824,770	12,940	520	4.0%
6213	Offices of Other Health Practitioners	124,498	\$419	614,171	8,790	600	6.8%

Table V-1
Profile of General Industry Establishments Covered by the Final Standard for Subparts D and I (continued)

NAICS	NAICS Description	Establishments	Average Receipts per Establishment (\$1,000)[a]	Total Employees	Production Employees		
					Total No. of Production Employees[b]	Production Employees in At-Risk Occupations (Construction, Installation, Maintenance, and Repair Occupations)[c]	
						Number	Share of Production Employees
6214	Outpatient Care Centers	29,644	\$2,685	695,863	11,810	3,680	31.2%
6215	Medical and Diagnostic Laboratories	12,798	\$2,953	221,709	2,270	490	21.6%
6216	Home Health Care Services	24,443	\$2,096	1,021,573	5,970	1,190	19.9%
6219	Other Ambulatory Health Care Services	9,422	\$2,926	269,271	18,900	2,670	14.1%
6221	General Medical and Surgical Hospitals	5,404	\$120,585	5,041,848	285,300	65,370	22.9%
6222	Psychiatric and Substance Abuse Hospitals	718	\$24,937	216,343	17,010	5,560	32.7%
6223	Specialty (except Psychiatric and Substance Abuse) Hospitals	1,230	\$21,388	219,627	11,000	2,520	22.9%
6231	Nursing Care Facilities	17,132	\$5,569	1,646,321	163,850	21,780	13.3%
6232	Residential Mental Retardation, Mental Health and Substance Abuse Facilities	31,571	\$786	557,907	19,920	5,110	25.7%
6233	Community Care Facilities for the Elderly	20,351	\$1,872	685,024	75,920	14,370	18.9%
6239	Other Residential Care Facilities	6,552	\$1,262	153,881	6,560	2,290	34.9%

**Table V-1
Profile of General Industry Establishments Covered by the Final Standard for Subparts D and I (continued)**

NAICS	NAICS Description	Establishments	Average Receipts per Establishment (\$1,000)[a]	Total Employees	Production Employees		
					Total No. of Production Employees[b]	Production Employees in At-Risk Occupations (Construction, Installation, Maintenance, and Repair Occupations)[c]	
						Number	Share of Production Employees
6241	Individual and Family Services	57,712	\$1,089	1,108,173	44,900	5,560	12.4%
6242	Community Food and Housing, and Emergency and Other Relief Services	13,710	\$1,630	167,691	13,300	3,550	26.7%
6243	Vocational Rehabilitation Services	7,905	\$1,590	330,145	71,170	3,480	4.9%
6244	Child Day Care Services	74,763	\$396	853,648	18,050	1,760	9.8%
7111	Performing Arts Companies	9,453	\$1,502	134,434	7,930	3,150	39.7%
7112	Spectator Sports	4,631	\$6,550	126,092	19,190	7,020	36.6%
7113	Promoters of Performing Arts, Sports, and Similar Events	6,367	\$2,485	112,354	14,710	3,530	24.0%
7114	Agents and Managers for Artists, Athletes, Entertainers, and Other Public Figures	3,722	\$1,290	17,420	220	90	40.9%
7115	Independent Artists, Writers, and Performers	20,087	\$664	45,772	3,360	710	21.1%
7121	Museums, Historical Sites, and Similar Institutions	7,312	\$1,780	128,539	14,880	4,420	29.7%
7131	Amusement Parks and Arcades	3,097	\$4,407	128,369	21,320	9,590	45.0%
7132	Gambling Industries	2,729	\$11,700	205,307	18,360	5,240	28.5%

Table V-1
Profile of General Industry Establishments Covered by the Final Standard for Subparts D and I (continued)

NAICS	NAICS Description	Establishments	Average Receipts per Establishment (\$1,000)[a]	Total Employees	Production Employees		
					Total No. of Production Employees[b]	Production Employees in At-Risk Occupations (Construction, Installation, Maintenance, and Repair Occupations)[c]	
						Number	Share of Production Employees
7139	Other Amusement and Recreation Industries	67,824	\$869	1,110,280	211,410	44,390	21.0%
7211	Traveler Accommodation	54,268	\$3,117	1,856,110	663,680	80,540	12.1%
7212	RV (Recreational Vehicle) Parks and Recreational Camps	7,434	\$594	39,717	10,580	5,830	55.1%
7213	Rooming and Boarding Houses	2,201	\$426	11,727	3,580	490	13.7%
7221	Full-Service Restaurants	219,472	\$876	4,579,941	57,180	3,580	6.3%
7222	Limited-Service Eating Places	266,844	\$700	4,136,741	197,820	4,080	2.1%
7223	Special Food Services	35,322	\$1,087	575,579	50,990	6,610	13.0%
7224	Drinking Places (Alcoholic Beverages)	46,948	\$394	365,049	6,420	690	10.7%
8111	Automotive Repair and Maintenance	166,369	\$538	893,198	710,480	457,970	64.5%
8112	Electronic and Precision Equipment Repair and Maintenance	12,917	\$1,966	135,243	64,330	56,920	88.5%
8113	Commercial and Industrial Machinery and Equipment (except Automotive and Electronic) Repair and Maintenance	23,897	\$1,333	199,239	136,820	90,410	66.1%

The parts of the final standard that cover ladders, scaffolds, manhole steps, and other working surfaces are most likely to directly affect employees

Table V-1
Profile of General Industry Establishments Covered by the Final Standard for Subparts D and I (continued)

NAICS	NAICS Description	Establishments	Average Receipts per Establishment (\$1,000)[a]	Total Employees	Production Employees		
					Total No. of Production Employees[b]	Production Employees in At-Risk Occupations (Construction, Installation, Maintenance, and Repair Occupations)[c]	
						Number	Share of Production Employees
8114	Personal and Household Goods Repair and Maintenance	22,948	\$406	95,272	58,360	29,940	51.3%
8121	Personal Care Services	113,125	\$239	616,538	7,010	420	6.0%
8122	Death Care Services	21,434	\$713	136,928	29,670	1,790	6.0%
8123	Dry-cleaning and Laundry Services	41,331	\$601	374,356	241,120	6,800	2.8%
8129	Other Personal Services	36,640	\$511	252,462	106,250	3,680	3.5%
8131	Religious Organizations	180,304	\$698	1,691,182	25,010	4,940	19.8%
8132	Grantmaking and Giving Services	16,356	\$5,742	146,709	3,650	700	19.2%
8133	Social Advocacy Organizations	15,431	\$1,228	128,522	8,780	2,340	26.7%
8134	Civic and Social Organizations	29,817	\$623	330,219	27,510	4,540	16.5%
8139	Business, Professional, Labor, Political, and Similar Organizations	63,683	\$1,222	519,905	42,440	18,030	42.5%
	Totals	6,855,903		112,328,837	27,787,879	5,226,602	18.8%

[a] Estimated based on 2007 receipts and establishment data from U.S. Census Bureau, Statistics of U.S. Businesses, 2007.

[b] These employment estimates are based on applying the share of workers employed in building and grounds; construction; installation, maintenance, and repair; production; and material-moving occupations as reported by BLS, Occupational Employment Statistics, 2007 to total employment levels as reported by U.S. Census Bureau, Statistics of U.S. Businesses, 2007.

[c] Bureau of Labor Statistics, Occupational Employment Statistics, 2007.

[d] NA: Data not available; term used throughout this FEA.

Source: U.S. Department of Labor, OSHA, Directorate of Standards and Guidance, Office of Regulatory Analysis-Safety.

engaged in maintenance and related activities. To estimate the numbers of such employees, OSHA relied on data from the Bureau of Labor Statistics' (BLS) *Occupational Employment Statistics* (OES) survey documenting employment by detailed occupation using 4-digit NAICS industry codes. The BLS data represent the only source of industry-specific statistics on detailed occupational employment totals. OSHA used these data to estimate the numbers of employees in construction and in maintenance, installation, and repair occupations in each industry, as well as the overall number of production employees.¹⁰⁴ As shown in Table V-1,

¹⁰⁴ Production workers include those in building and grounds; construction; installation, maintenance, and repair; production; and material moving occupations. It is possible that employees in construction and related occupations, even though not employed by establishments in construction industries, might perform work regulated by OSHA under its construction standards in 29 CFR part 1926. Therefore, the employers of these workers, depending on the type of work performed, also may have to meet the requirements for fall protection and walking-

an estimated 27.8 million employees are in production occupations, while an estimated 5.2 million are in construction, installation, and maintenance and repair occupations.

3. Profile of Potentially Affected Small Entities

To assemble the data necessary for a screening analysis to determine potential impacts on small entities as prescribed by the Regulatory Flexibility Act, OSHA developed profiles of small entities in the industries covered by the final OSHA standards for subparts D and I. OSHA used the Small Business Administration's (SBA) small business criterion for each industry and Census data (taken from the *Statistics of U.S. Businesses*) on employment, payroll, and receipts by entity size to estimate

working surfaces specified in the construction standards. To the extent that these workers may be subject to both the general industry fall protection standard and the construction fall protection standard, the final rule increases harmonization with the construction fall protection standards, rather than generating new costs or worker-safety benefits.

the numbers of entities and associated employment meeting the SBA definitions. When the SBA specified the small business criterion as a revenue threshold, OSHA used the Census data to associate that revenue with a given employment size. The first column of Table V-2 provides OSHA's estimates of SBA-based employment-size criteria. This table shows, for each NAICS industry code, the number of entities and employees, and average receipts per entity, for business units that meet the employment-size criterion. OSHA estimated the numbers of at-risk employees by applying the percentage of at-risk small-entity employees estimated in the PEA to total estimated small-entity employment, after deriving the latter estimate from updated (2007) Census data on the number of affected small entities.

OSHA also used the Census data to develop a profile of entities that employ fewer than 20 employees. Table V-3 provides these estimates.

BILLING CODE 4510-19-P

**Table V-2
Profile of General Industry Small Business Entities Covered by the Final Standard for Subparts D and I**

NAICS	NAICS Description	SBA Employment Size or Annual Receipts Criterion[a]	Entities[b]	Average Receipts per Entity[b]	Total Employees	Estimated Employment in At-Risk Production Occupations (Construction, Installation, Maintenance, and Repair Occupations) [c]
1131	Timber Tract Operations	500	389	\$1,203,946	1,853	NA
1132	Forest Nurseries and Gathering of Forest Products	500	169	\$978,953	1,521	NA
1133	Logging	500	9,714	\$985,859	57,067	2,464
1141	Fishing	20	2,039	\$1,071,290	2,601	NA
1142	Hunting and Trapping	20	323	\$696,350	812	NA
1153	Support Activities for Forestry	100	1,641	\$612,625	9,180	NA
2111	Oil and Gas Extraction	500	6,453	\$10,209,466	45,332	9,245
2211	Electric Power Generation, Transmission and Distribution	20	1,551	\$46,138,696	8,806	2,944
2212	Natural Gas Distribution	20	441	\$60,450,299	2,127	639
2213	Water, Sewage and Other Systems	100	3,918	\$1,197,612	19,257	4,235
3111	Animal Food Manufacturing	500	1,173	\$11,493,951	24,430	1,746
3112	Grain and Oilseed Milling	500	461	\$26,376,108	16,640	1,450
3113	Sugar and Confectionery Product Manufacturing	500	1,587	\$4,747,662	68,183	6,182
3114	Fruit and Vegetable Preserving and Specialty Food Manufacturing	500	1,221	\$18,280,614	45,938	3,318
3115	Dairy Product Manufacturing	500	1,031	\$22,265,319	28,609	1,522
3116	Animal Slaughtering and Processing	500	3,109	\$11,500,053	114,645	5,791

Table V-2
Profile of General Industry Small Business Entities Covered by the Final Standard for Subparts D and I (continued)

NAICS	NAICS Description	SBA Employment Size or Annual Receipts Criterion[a]	Entities[b]	Average Receipts per Entity[b]	Total Employees	Estimated Employment in At-Risk Production Occupations (Construction, Installation, Maintenance, and Repair Occupations) [c]
3117	Seafood Product Preparation and Packaging	500	574	\$10,176,408	8,943	378
3118	Bakeries and Tortilla Manufacturing	500	9,408	\$1,712,822	288,414	17,004
3119	Other Food Manufacturing	500	2,761	\$9,860,693	45,756	3,854
3121	Beverage Manufacturing	500	3,338	\$5,864,184	101,892	14,812
3122	Tobacco Manufacturing	500	72	\$20,077,861	2,215	289
3131	Fiber, Yam, and Thread Mills	500	281	\$7,063,009	9,472	288
3132	Fabric Mills	500	1,107	\$7,614,212	24,459	3,082
3133	Textile and Fabric Finishing and Fabric Coating Mills	500	1,259	\$4,778,704	16,917	705
3141	Textile Furnishings Mills	500	2,418	\$1,906,425	48,147	4,121
3149	Other Textile Product Mills	500	3,994	\$1,883,709	60,009	1,723
3151	Apparel Knitting Mills	500	433	\$3,537,748	14,417	2,384
3152	Cut and Sew Apparel Manufacturing	500	8,772	\$2,157,055	130,265	1,124
3159	Apparel Accessories and Other Apparel Manufacturing	500	884	\$1,466,456	13,021	1,169
3161	Leather and Hide Tanning and Finishing	500	230	\$4,184,696	4,203	236
3162	Footwear Manufacturing	500	274	\$2,586,898	5,656	201
3169	Other Leather and Allied Product Manufacturing	500	821	\$2,272,834	12,685	127
3211	Sawmills and Wood Preservation	500	3,662	\$5,030,554	82,529	114

Table V-2
Profile of General Industry Small Business Entities Covered by the Final Standard for Subparts D and I (continued)

NAICS	NAICS Description	SBA Employment Size or Annual Receipts Criterion[a]	Entities[b]	Average Receipts per Entity[b]	Total Employees	Estimated Employment in At-Risk Production Occupations (Construction, Installation, Maintenance, and Repair Occupations) [c]
3212	Veneer, Plywood, and Engineered Wood Product Manufacturing	500	1,444	\$6,305,821	62,374	6,544
3219	Other Wood Product Manufacturing	500	9,405	\$3,235,790	196,354	6,380
3221	Pulp, Paper, and Paperboard Mills	750	217	\$35,652,696	81,068	19,581
3222	Converted Paper Product Manufacturing	750	2,941	\$12,426,409	244,731	18,291
3231	Printing and Related Support Activities	500	31,414	\$1,868,047	438,816	15,574
3241	Petroleum and Coal Products Manufacturing	500	1,096	\$43,923,678	25,848	7,384
3251	Basic Chemical Manufacturing	500	1,290	\$38,377,584	39,224	4,007
3252	Resin, Synthetic Rubber, and Artificial Synthetic Fibers and Filaments Manufacturing	500	685	\$29,953,311	64,863	4,048
3253	Pesticide, Fertilizer, and Other Agricultural Chemical Manufacturing	500	633	\$10,129,959	11,603	8,778
3254	Pharmaceutical and Medicine Manufacturing	500	1,385	\$15,311,811	52,038	1,465
3255	Paint, Coating, and Adhesive Manufacturing	500	1,446	\$7,227,237	30,360	2,309
3256	Soap, Cleaning Compound, and Toilet Preparation Manufacturing	500	1,938	\$10,379,385	46,183	1,208
3259	Other Chemical Product and Preparation Manufacturing	500	2,068	\$7,196,531	46,088	2,965
3261	Plastics Product Manufacturing	500	9,146	\$8,186,170	342,785	19,005
3262	Rubber Product Manufacturing	500	1,628	\$8,522,571	52,434	3,355
3271	Clay Product and Refractory Manufacturing	500	1,304	\$3,357,373	25,229	1,994

Table V-2
Profile of General Industry Small Business Entities Covered by the Final Standard for Subparts D and I (continued)

NAICS	NAICS Description	SBA Employment Size or Annual Receipts Criterion[a]	Entities[b]	Average Receipts per Entity[b]	Total Employees	Estimated Employment in At-Risk Production Occupations (Construction, Installation, Maintenance, and Repair Occupations) [c]
3272	Glass and Glass Product Manufacturing	500	1,726	\$3,067,226	30,210	2,842
3273	Cement and Concrete Product Manufacturing	500	5,020	\$6,750,795	129,383	19,243
3274	Lime and Gypsum Product Manufacturing	500	202	\$6,856,391	3,423	623
3279	Other Nonmetallic Mineral Product Manufacturing	500	2,937	\$3,124,333	52,410	6,847
3311	Iron and Steel Mills and Ferroalloy Manufacturing	750	730	\$25,589,719	87,419	17,941
3312	Steel Product Manufacturing from Purchased Steel	1,000	497	\$23,334,183	40,337	3,591
3313	Alumina and Aluminum Production and Processing	750	421	\$22,520,990	49,735	7,454
3314	Nonferrous Metal (except Aluminum) Production and Processing	750	676	\$24,254,840	44,394	4,551
3315	Foundries	500	1,796	\$9,587,227	76,306	6,324
3321	Forging and Stamping	500	2,301	\$9,378,614	82,843	4,872
3322	Cutlery and Handtool Manufacturing	500	1,333	\$4,684,161	28,710	1,114
3323	Architectural and Structural Metals Manufacturing	500	12,517	\$4,646,354	276,206	26,024
3324	Boiler, Tank, and Shipping Container Manufacturing	500	1,214	\$8,914,855	43,393	NA
3325	Hardware Manufacturing	500	673	\$6,541,624	18,729	660
3326	Spring and Wire Product Manufacturing	500	1,395	\$4,646,072	38,974	1,351

Table V-2
Profile of General Industry Small Business Entities Covered by the Final Standard for Subparts D and I (continued)

NAICS	NAICS Description	SBA Employment Size or Annual Receipts Criterion[a]	Entities[b]	Average Receipts per Entity[b]	Total Employees	Estimated Employment in At-Risk Production Occupations (Construction, Installation, Maintenance, and Repair Occupations) [c]
3327	Machine Shops; Turned Product; and Screw, Nut, and Bolt Manufacturing	500	24,638	\$2,055,754	350,609	8,633
3328	Coating, Engraving, Heat Treating, and Allied Activities	500	5,526	\$3,605,034	114,874	4,720
3329	Other Fabricated Metal Product Manufacturing	500	5,625	\$5,096,298	129,261	7,382
3331	Agriculture, Construction, and Mining Machinery Manufacturing	500	2,640	\$9,370,238	76,342	4,175
3332	Industrial Machinery Manufacturing	500	3,510	\$5,062,247	84,087	4,092
3333	Commercial and Service Industry Machinery Manufacturing	500	2,013	\$5,155,096	49,422	2,527
3334	Ventilation, Heating, Air-Conditioning, and Commercial Refrigeration Equipment Manufacturing	500	1,397	\$7,687,392	47,346	4,071
3335	Metalworking Machinery Manufacturing	500	7,595	\$2,688,982	136,043	3,530
3336	Engine, Turbine, and Power Transmission Equipment Manufacturing	500	704	\$10,107,295	23,050	1,835
3339	Other General Purpose Machinery Manufacturing	500	5,361	\$6,204,507	136,111	7,822
3341	Computer and Peripheral Equipment Manufacturing	1000	1,184	\$8,999,667	90,336	1,919
3342	Communications Equipment Manufacturing	750	1,517	\$10,202,121	113,536	4,448
3343	Audio and Video Equipment Manufacturing	750	496	\$6,870,034	16,243	484

Table V-2
Profile of General Industry Small Business Entities Covered by the Final Standard for Subparts D and I (continued)

NAICS	NAICS Description	SBA Employment Size or Annual Receipts Criterion[a]	Entities[b]	Average Receipts per Entity[b]	Total Employees	Estimated Employment in At-Risk Production Occupations (Construction, Installation, Maintenance, and Repair Occupations) [c]
3344	Semiconductor and Other Electronic Component Manufacturing	500	4,039	\$7,260,568	137,336	4,003
3345	Navigational, Measuring, Electromedical, and Control Instruments Manufacturing	500	4,395	\$7,395,335	102,427	3,141
3346	Manufacturing and Reproducing Magnetic and Optical Media	500	750	\$2,906,879	13,084	560
3351	Electric Lighting Equipment Manufacturing	500	1,102	\$6,643,417	30,592	1,519
3352	Household Appliance Manufacturing	500	279	\$6,797,928	8,485	369
3353	Electrical Equipment Manufacturing	500	1,971	\$6,751,929	109,035	5,017
3359	Other Electrical Equipment and Component Manufacturing	500	1,743	\$12,491,840	61,363	2,801
3361	Motor Vehicle Manufacturing	1,000	276	\$17,156,736	180,996	18,472
3362	Motor Vehicle Body and Trailer Manufacturing	500	1,851	\$8,209,713	65,570	4,562
3363	Motor Vehicle Parts Manufacturing	500	4,227	\$13,098,070	167,903	12,979
3364	Aerospace Product and Parts Manufacturing	1,000	1,275	\$10,267,905	364,351	37,310
3365	Railroad Rolling Stock Manufacturing	1000	141	\$10,698,766	24,859	3,892
3366	Ship and Boat Building	500	1,612	\$7,121,573	44,862	8,624
3369	Other Transportation Equipment Manufacturing	500	986	\$5,566,299	19,177	1,144
3371	Household and Institutional Furniture and Kitchen Cabinet Manufacturing	500	16,089	\$1,588,275	213,696	13,410

Table V-2
Profile of General Industry Small Business Entities Covered by the Final Standard for Subparts D and I (continued)

NAICS	NAICS Description	SBA Employment Size or Annual Receipts Criterion[a]	Entities[b]	Average Receipts per Entity[b]	Total Employees	Estimated Employment in At-Risk Production Occupations (Construction, Installation, Maintenance, and Repair Occupations) [c]
3372	Office Furniture (including Fixtures) Manufacturing	500	3,866	\$4,005,842	95,911	4,836
3379	Other Furniture Related Product Manufacturing	500	888	\$5,630,860	24,364	792
3391	Medical Equipment and Supplies Manufacturing	500	11,227	\$2,581,520	146,894	3,307
3399	Other Miscellaneous Manufacturing	500	18,259	\$2,391,579	267,657	12,600
4231	Motor Vehicle and Motor Vehicle Parts and Supplies Merchant Wholesalers	100	16,942	\$5,214,828	158,506	22,863
4232	Furniture and Home Furnishing Merchant Wholesalers	100	10,468	\$5,505,483	92,798	2,424
4233	Lumber and Other Construction Materials Merchant Wholesalers	100	12,190	\$5,017,184	126,964	6,694
4234	Professional and Commercial Equipment and Supplies Merchant Wholesalers	100	25,371	\$3,924,436	216,960	22,318
4235	Metal and Mineral (except Petroleum) Merchant Wholesalers	100	6,957	\$11,382,651	75,895	2,060
4236	Electrical and Electronic Goods Merchant Wholesalers	100	19,024	\$6,108,282	174,753	12,815
4237	Hardware, and Plumbing and Heating Equipment and Supplies Merchant Wholesalers	100	10,751	\$4,408,710	112,753	8,440
4238	Machinery, Equipment, and Supplies Merchant Wholesalers	100	41,809	\$4,727,813	397,348	79,924

Table V-2
Profile of General Industry Small Business Entities Covered by the Final Standard for Subparts D and I (continued)

NAICS	NAICS Description	SBA Employment Size or Annual Receipts Criterion[a]	Entities[b]	Average Receipts per Entity[b]	Total Employees	Estimated Employment in At-Risk Production Occupations (Construction, Installation, Maintenance, and Repair Occupations) [c]
4239	Miscellaneous Durable Goods Merchant Wholesalers	100	30,313	\$5,269,697	206,395	10,859
4241	Paper and Paper Product Merchant Wholesalers	100	8,752	\$4,176,774	74,791	977
4242	Drugs and Druggists' Sundries Merchant Wholesalers	100	5,838	\$5,856,288	47,228	338
4243	Apparel, Piece Goods, and Notions Merchant Wholesalers	100	14,426	\$5,680,399	107,539	382
4244	Grocery and Related Product Wholesalers	100	26,532	\$7,708,002	251,866	5,824
4245	Farm Product Raw Material Merchant Wholesalers	100	3,844	\$14,484,724	38,877	823
4246	Chemical and Allied Products Merchant Wholesalers	100	7,934	\$6,324,060	65,806	2,690
4247	Petroleum and Petroleum Products Merchant Wholesalers	100	4,478	\$45,709,900	49,559	3,093
4248	Beer, Wine, and Distilled Alcoholic Beverage Merchant Wholesalers	100	2,999	\$10,952,519	53,042	662
4249	Miscellaneous Nondurable Goods Merchant Wholesalers	100	24,660	\$3,695,365	175,492	2,869
4251	Wholesale Electronic Markets and Agents and Brokers	100	53,561	\$7,231,541	205,641	8,062
4411	Automobile Dealers	20	44,316	\$10,000,839	187,350	47,515
4412	Other Motor Vehicle Dealers	100	15,120	\$3,771,504	135,969	40,929

Table V-2
Profile of General Industry Small Business Entities Covered by the Final Standard for Subparts D and I (continued)

NAICS	NAICS Description	SBA Employment Size or Annual Receipts Criterion[a]	Entities[b]	Average Receipts per Entity[b]	Total Employees	Estimated Employment in At-Risk Production Occupations (Construction, Installation, Maintenance, and Repair Occupations) [c]
4413	Automotive Parts, Accessories, and Tire Stores	100	32,330	\$1,326,586	216,682	69,213
4421	Furniture Stores	100	19,802	\$1,791,250	152,175	2,020
4422	Home Furnishings Stores	100	26,202	\$1,147,520	143,330	12,668
4431	Electronics and Appliance Stores	20	30,335	\$1,280,230	119,295	14,960
4441	Building Material and Supplies Dealers	100	45,176	\$2,578,176	429,244	16,981
4442	Lawn and Garden Equipment and Supplies Stores	100	16,635	\$2,033,779	128,453	13,246
4451	Grocery Stores	100	65,430	\$1,691,208	513,196	794
4452	Specialty Food Stores	100	23,426	\$756,131	131,540	587
4453	Beer, Wine, and Liquor Stores	100	26,833	\$1,134,826	122,074	106
4461	Health and Personal Care Stores	100	43,539	\$1,855,531	309,116	1,177
4471	Gasoline Stations	100	65,359	\$3,601,756	447,962	16,468
4481	Clothing Stores	100	40,794	\$816,092	212,226	131
4482	Shoe Stores	100	6,641	\$1,032,767	42,316	7
4483	Jewelry, Luggage, and Leather Goods Stores	100	19,038	\$990,006	84,653	867
4511	Sporting Goods, Hobby, and Musical Instrument Stores	100	31,702	\$823,248	180,867	6,808
4512	Book, Periodical, and Music Stores	100	9,053	\$736,118	51,358	47
4521	Department Stores	100	394	\$1,609,330	2,431	18
4529	Other General Merchandise Stores	100	10,002	\$844,811	53,983	886

Table V-2
Profile of General Industry Small Business Entities Covered by the Final Standard for Subparts D and I (continued)

NAICS	NAICS Description	SBA Employment Size or Annual Receipts Criterion[a]	Entities[b]	Average Receipts per Entity[b]	Total Employees	Estimated Employment in At-Risk Production Occupations (Construction, Installation, Maintenance, and Repair Occupations) [c]
4531	Florists	100	18,941	\$331,146	91,421	169
4532	Office Supplies, Stationery, and Gift Stores	500	28,693	\$592,924	169,928	5,329
4533	Used Merchandise Stores	100	13,005	\$563,158	62,101	591
4539	Other Miscellaneous Store Retailers	100	36,844	\$1,081,911	179,402	9,414
4541	Electronic Shopping and Mail-Order Houses	100	14,940	\$2,969,058	97,777	786
4542	Vending Machine Operators	100	4,518	\$1,136,446	25,972	8,371
4543	Direct Selling Establishments	20	19,679	\$1,138,456	80,204	12,583
4811	Scheduled Air Transportation	1,500	538	\$18,310,617	421,990	35,095
4812	Nonscheduled Air Transportation	1,500	2,304	\$3,858,824	41,061	6,708
4831	Deep Sea, Coastal, and Great Lakes Water Transportation	20	838	\$10,116,311	20,390	590
4832	Inland Water Transportation	500	580	\$3,594,686	11,410	343
4841	General Freight Trucking	500	58,091	\$1,289,155	468,958	22,261
4842	Specialized Freight Trucking	500	47,947	\$1,150,500	370,325	20,262
4851	Urban Transit Systems	100	566	\$1,456,261	7,629	822
4852	Interurban and Rural Bus Transportation	100	224	\$2,476,679	2,825	175
4853	Taxi and Limousine Service	500	7,290	\$682,884	58,923	1,486
4854	School and Employee Bus Transportation	100	3,045	\$1,090,597	44,910	1,544
4855	Charter Bus Industry	500	1,118	\$1,593,885	22,171	1,259

Table V-2
Profile of General Industry Small Business Entities Covered by the Final Standard for Subparts D and I (continued)

NAICS	NAICS Description	SBA Employment Size or Annual Receipts Criterion[a]	Entities[b]	Average Receipts per Entity[b]	Total Employees	Estimated Employment in At-Risk Production Occupations (Construction, Installation, Maintenance, and Repair Occupations) [c]
4859	Other Transit and Ground Passenger Transportation	500	3,196	\$1,197,890	51,469	1,532
4861	Pipeline Transportation of Crude Oil	1,500	42	\$20,494,772	5,608	1,110
4862	Pipeline Transportation of Natural Gas	500	84	\$27,363,548	1,771	362
4869	Other Pipeline Transportation	500	56	\$20,316,946	972	183
4871	Scenic and Sightseeing Transportation, Land	500	635	\$880,647	6,041	246
4872	Scenic and Sightseeing Transportation, Water	500	1,821	\$619,058	9,616	242
4879	Scenic and Sightseeing Transportation, Other	100	188	\$2,089,665	1,246	192
4881	Support Activities for Air Transportation	100	3,947	\$1,815,260	33,439	9,409
4882	Support Activities for Rail Transportation	100	480	\$2,650,352	6,481	2,191
4883	Support Activities for Water Transportation	100	1,765	\$3,068,905	16,036	988
4884	Support Activities for Road Transportation	100	9,249	\$628,543	55,941	3,056
4885	Freight Transportation Arrangement	100	12,667	\$2,172,906	88,629	867
4889	Other Support Activities for Transportation	100	1,551	\$1,204,640	10,187	310
4921	Couriers	1,500	3,747	\$1,115,230	536,711	13,251
4922	Local Messengers and Local Delivery	500	4,330	\$958,560	33,363	109
4931	Warehousing and Storage	100	7,410	\$5,391,522	84,202	2,648
5111	Newspaper, Periodical, Book, and Directory Publishers	500	16,643	\$2,637,887	240,210	1,946
5112	Software Publishers	500	5,601	\$4,259,862	106,847	715

Table V-2
Profile of General Industry Small Business Entities Covered by the Final Standard for Subparts D and I (continued)

NAICS	NAICS Description	SBA Employment Size or Annual Receipts Criterion[a]	Entities[b]	Average Receipts per Entity[b]	Total Employees	Estimated Employment in At-Risk Production Occupations (Construction, Installation, Maintenance, and Repair Occupations) [c]
5121	Motion Picture and Video Industries	500	17,429	\$1,438,874	120,398	1,027
5122	Sound Recording Industries	100	3,425	\$482,983	12,256	127
5151	Radio and Television Broadcasting	20	4,606	\$2,229,432	28,943	317
5152	Cable and Other Subscription Programming	500	341	\$10,561,328	6,809	1,824
5161	Internet Publishing and Broadcasting	500	2,333	\$2,351,160	19,451	NA
5171	Wired Telecommunications Carriers	1,500	2,004	\$8,334,605	493,023	166,379
5172	Wireless Telecommunications Carriers (except Satellite)	1,500	1,711	\$5,075,123	160,166	8,958
5173	Telecommunications Resellers	1,500	3,107	\$4,290,738	43,851	N/A
5174	Satellite Telecommunications	1,000	530	\$5,662,560	13,492	2,093
5175	Cable and Other Program Distribution	1,000	947	\$2,953,364	175,981	NA
5179	Other Telecommunications	1,000	1,260	\$1,767,175	27,622	NA
5181	Internet Service Providers and Web Search Portals	1,000	3,747	\$2,120,052	58,322	1,620
5182	Data Processing, Hosting, and Related Services	1,000	7,112	\$3,189,773	339,914	NA
5191	Other Information Services	1,000	3,349	\$917,716	53,714	4,858
5211	Monetary Authorities - Central Bank	1,000	53	\$5,712,321	14,044	164
5221	Depository Credit Intermediation	20	15,010	\$12,178,211	107,239	738
5222	Nondepository Credit Intermediation	100	23,197	\$4,708,135	136,331	106
5223	Activities Related to Credit Intermediation	20	27,577	\$940,918	92,463	243

Table V-2
Profile of General Industry Small Business Entities Covered by the Final Standard for Subparts D and I (continued)

NAICS	NAICS Description	SBA Employment Size or Annual Receipts Criterion[a]	Entities[b]	Average Receipts per Entity[b]	Total Employees	Estimated Employment in At-Risk Production Occupations (Construction, Installation, Maintenance, and Repair Occupations) [c]
5231	Securities and Commodity Contracts Intermediation and Brokerage	100	12,731	\$3,449,331	61,945	260
5232	Securities and Commodity Exchanges	100	117	\$7,093,103	699	57
5239	Other Financial Investment Activities	100	43,788	\$2,678,726	173,174	14
5241	Insurance Carriers	100	6,849	\$13,103,280	51,770	419
5242	Agencies, Brokerages, and Other Insurance Related Activities	20	130,229	\$737,898	415,001	150
5259	Other Investment Pools and Funds	20	1,965	\$2,111,505	4,448	488
5311	Lessors of Real Estate	100	95,427	\$1,040,229	361,764	84,509
5312	Offices of Real Estate Agents and Brokers	100	100,495	\$700,288	257,710	17,563
5313	Activities Related to Real Estate	100	73,945	\$751,556	363,692	65,945
5321	Automotive Equipment Rental and Leasing	500	4,629	\$1,924,714	38,958	5,747
5322	Consumer Goods Rental	100	12,034	\$676,881	82,488	4,970
5323	General Rental Centers	100	3,167	\$1,108,941	21,849	2,506
5324	Commercial and Industrial Machinery and Equipment Rental and Leasing	100	8,368	\$2,391,534	64,230	3,603
5331	Lessors of Nonfinancial Intangible Assets (except Copyrighted Works)	100	2,335	\$3,451,840	16,632	336
5411	Legal Services	100	180,282	\$936,065	831,572	157
5412	Accounting, Tax Preparation, Bookkeeping, and Payroll Services	500	107,843	\$549,498	681,543	3,754

Table V-2
Profile of General Industry Small Business Entities Covered by the Final Standard for Subparts D and I (continued)

NAICS	NAICS Description	SBA Employment Size or Annual Receipts Criterion[a]	Entities[b]	Average Receipts per Entity[b]	Total Employees	Estimated Employment in At-Risk Production Occupations (Construction, Installation, Maintenance, and Repair Occupations) [c]
5413	Architectural, Engineering, and Related Services	100	98,918	\$1,456,915	682,282	28,540
5414	Specialized Design Services	100	34,304	\$675,008	117,793	1,918
5415	Computer Systems Design and Related Services	500	102,538	\$1,270,944	686,853	11,446
5416	Management, Scientific, and Technical Consulting Services	100	141,356	\$844,068	502,134	12,600
5417	Scientific Research and Development Services	100	13,440	\$3,555,301	121,091	2,307
5418	Advertising and Related Services	500	36,283	\$1,506,332	271,265	4,460
5419	Other Professional, Scientific, and Technical Services	500	64,099	\$780,896	460,168	3,166
5511	Management of Companies and Enterprises	100	20,794	\$3,630,215	154,193	4,331
5611	Office Administrative Services	100	25,338	\$1,691,252	186,112	4,422
5612	Facilities Support Services	500	1,500	\$3,068,841	41,933	5,492
5613	Employment Services	100	23,151	\$1,925,441	377,202	26,725
5614	Business Support Services	100	29,302	\$968,918	210,992	1,232
5615	Travel Arrangement and Reservation Services	100	16,703	\$995,690	88,955	607
5616	Investigation and Security Services	100	19,479	\$876,855	177,631	12,671
5617	Services to Buildings and Dwellings	100	172,700	\$480,087	953,744	29,835
5619	Other Support Services	100	18,223	\$1,435,410	125,853	7,503
5621	Waste Collection	500	7,666	\$1,877,005	87,779	7,912

Table V-2
Profile of General Industry Small Business Entities Covered by the Final Standard for Subparts D and I (continued)

NAICS	NAICS Description	SBA Employment Size or Annual Receipts Criterion[a]	Entities[b]	Average Receipts per Entity[b]	Total Employees	Estimated Employment in At-Risk Production Occupations (Construction, Installation, Maintenance, and Repair Occupations) [c]
5622	Waste Treatment and Disposal	100	1,534	\$3,298,771	14,175	2,492
5629	Remediation and Other Waste Management Services	100	7,883	\$1,690,585	69,976	36,457
6111	Elementary and Secondary Schools	100	16,490	\$3,380,040	432,755	5,047
6112	Junior Colleges	500	288	\$8,113,083	22,232	379
6113	Colleges, Universities, and Professional Schools	100	1,718	\$7,571,236	31,773	824
6114	Business Schools and Computer and Management Training	100	6,832	\$1,089,675	39,887	282
6115	Technical and Trade Schools	500	6,442	\$1,090,769	71,095	1,478
6116	Other Schools and Instruction	100	35,635	\$389,292	238,750	1,245
6117	Educational Support Services	100	5,917	\$1,201,135	33,541	83
6211	Offices of Physicians	100	189,252	\$1,400,668	1,382,978	2,478
6212	Offices of Dentists	100	120,488	\$755,088	785,251	395
6213	Offices of Other Health Practitioners	100	112,089	\$410,243	481,487	513
6214	Outpatient Care Centers	500	12,233	\$2,778,276	325,291	2,191
6215	Medical and Diagnostic Laboratories	500	7,464	\$2,696,196	111,982	245
6216	Home Health Care Services	20	15,764	\$1,542,557	73,107	89
6219	Other Ambulatory Health Care Services	100	5,449	\$2,238,978	80,159	948
6221	General Medical and Surgical Hospitals	20	1,674	\$17,794,953	4,592	60
6222	Psychiatric and Substance Abuse Hospitals	20	326	\$12,990,991	1,259	28

Table V-2
Profile of General Industry Small Business Entities Covered by the Final Standard for Subparts D and I (continued)

NAICS	NAICS Description	SBA Employment Size or Annual Receipts Criterion[a]	Entities[b]	Average Receipts per Entity[b]	Total Employees	Estimated Employment in At-Risk Production Occupations (Construction, Installation, Maintenance, and Repair Occupations) [c]
6223	Specialty (except Psychiatric and Substance Abuse) Hospitals	20	401	\$7,388,554	1,236	15
6231	Nursing Care Facilities	500	7,832	\$5,346,830	732,737	9,728
6232	Residential Mental Retardation, Mental Health and Substance Abuse Facilities	100	8,036	\$1,815,049	149,756	1,416
6233	Community Care Facilities for the Elderly	100	14,491	\$1,361,752	213,645	4,616
6239	Other Residential Care Facilities	100	3,523	\$1,714,968	58,973	837
6241	Individual and Family Services	100	40,591	\$1,237,965	462,899	2,300
6242	Community Food and Housing, and Emergency and Other Relief Services	100	9,325	\$2,074,994	110,080	2,807
6243	Vocational Rehabilitation Services	100	4,249	\$1,945,328	73,914	820
6244	Child Day Care Services	100	59,716	\$397,468	600,199	1,226
7111	Performing Arts Companies	500	9,255	\$1,257,784	114,240	3,150
7112	Spectator Sports	100	4,194	\$4,107,867	28,305	1,641
7113	Promoters of Performing Arts, Sports, and Similar Events	20	5,982	\$1,371,807	19,449	773
7114	Agents and Managers for Artists, Athletes, Entertainers, and Other Public Figures	500	3,620	\$1,113,019	15,388	72
7115	Independent Artists, Writers, and Performers	500	20,044	\$629,580	45,037	942
7121	Museums, Historical Sites, and Similar Institutions	100	6,778	\$1,471,038	72,964	2,685
7131	Amusement Parks and Arcades	100	2,555	\$954,517	24,165	1,439

Table V-2
Profile of General Industry Small Business Entities Covered by the Final Standard for Subparts D and I (continued)

NAICS	NAICS Description	SBA Employment Size or Annual Receipts Criterion[a]	Entities[b]	Average Receipts per Entity[b]	Total Employees	Estimated Employment in At-Risk Production Occupations (Construction, Installation, Maintenance, and Repair Occupations) [c]
7132	Gambling Industries	500	1,988	\$4,195,691	68,138	2,078
7139	Other Amusement and Recreation Industries	100	61,465	\$733,766	613,317	24,522
7211	Traveler Accommodation	100	43,818	\$1,224,034	512,443	23,378
7212	RV (Recreational Vehicle) Parks and Recreational Camps	100	6,809	\$573,403	30,846	4,017
7213	Rooming and Boarding Houses	100	2,117	\$390,860	9,699	481
7221	Full-Service Restaurants	500	188,281	\$674,755	3,026,084	2,251
7222	Limited-Service Eating Places	100	173,832	\$656,624	1,847,022	1,978
7223	Special Food Services	100	15,095	\$713,151	130,617	1,316
7224	Drinking Places (Alcoholic Beverages)	100	46,253	\$383,764	329,754	646
8111	Automotive Repair and Maintenance	100	152,030	\$541,795	751,162	389,884
8112	Electronic and Precision Equipment Repair and Maintenance	20	11,232	\$893,997	39,042	20,321
8113	Commercial and Industrial Machinery and Equipment (except Automotive and Electronic) Repair and Maintenance	100	21,850	\$1,029,875	125,774	61,417
8114	Personal and Household Goods Repair and Maintenance	500	21,868	\$344,533	74,913	28,262
8121	Personal Care Services	100	96,852	\$232,216	480,685	286
8122	Death Care Services	20	15,760	\$775,267	75,571	875
8123	Dry-cleaning and Laundry Services	20	33,896	\$400,368	140,742	2,799

Table V-2
Profile of General Industry Small Business Entities Covered by the Final Standard for Subparts D and I (continued)

NAICS	NAICS Description	SBA Employment Size or Annual Receipts Criterion[a]	Entities[b]	Average Receipts per Entity[b]	Total Employees	Estimated Employment in At-Risk Production Occupations (Construction, Installation, Maintenance, and Repair Occupations) [c]
8129	Other Personal Services	20	25,713	\$458,703	83,124	1,109
8131	Religious Organizations	20	178,395	\$632,935	833,997	23,020
8132	Grantmaking and Giving Services	20	14,131	\$6,009,398	51,941	240
8133	Social Advocacy Organizations	20	13,019	\$1,211,695	57,049	719
8134	Civic and Social Organizations	20	26,900	\$621,150	123,552	1,279
8139	Business, Professional, Labor, Political, and Similar Organizations	20	60,844	\$1,119,240	253,206	10,996
	Totals		5,233,667		44,446,321	2,354,813

[a] 2016 SBA criteria specified in dollar terms converted to size-class definition based on average revenues for establishment size categories. OSHA applied the most restrictive criteria for 6-digit NAICS to the 4-digit NAICS level.

[b] U.S. Census Bureau, Statistics of U.S. Businesses, 2007.

[c] Based on Bureau of Labor Statistics, Occupational Employment Statistics, 2007. Assumes same share of at-risk production workers in construction, installation, maintenance, and repair occupations as derived for the PEA. For example, for NAICS 8139, OSHA estimated in the PEA that of the 242,744 total number of employees in small firms, 10,542 workers, or 4.3 percent, are in the at-risk production occupations (Table V-2, PEA). For this FEA, applied the at-risk percentage (4.3 percent) to the 2007 figure for employment, 253,206, to derive the number of workers (10,996) in at-risk occupations in NAICS 8139 in 2007.

NA: Data not available.

Source: U.S. Department of Labor, OSHA, Directorate of Standards and Guidance, Office of Regulatory Analysis-Safety.

Table V-3
Profile of General Industry Very Small Business Entities (Fewer Than 20 Employees) Covered by the Final Standard
for Subparts D and I

NAICS	NAICS Description	Entities[a]	Average Receipts per Entity[b]	Total Employees	Estimated Employment in At-Risk Production Occupations (Construction, Installation, Maintenance, and Repair Occupations)[c]
1131	Timber Tract Operations	371	\$904,288	1,853	NA
1132	Forest Nurseries and Gathering of Forest Products	154	\$662,500	549	NA
1133	Logging	9,231	\$719,994	39,961	1,726
1141	Fishing	2,039	\$502,802	2,601	NA
1142	Hunting and Trapping	312	\$293,641	721	NA
1153	Support Activities for Forestry	1,528	\$391,575	4,354	NA
2111	Oil and Gas Extraction	5,836	\$2,175,862	19,887	4,056
2211	Electric Power Generation, Transmission and Distribution	630	\$13,277,417	3,577	1,196
2212	Natural Gas Distribution	351	\$19,580,715	1,693	509
2213	Water, Sewage and Other Systems	3,766	\$539,579	19,257	4,235
3111	Animal Food Manufacturing	819	\$2,522,281	5,211	372
3112	Grain and Oilseed Milling	277	\$3,868,422	1,782	156
3113	Sugar and Confectionery Product Manufacturing	1,587	\$585,509	9,210	788
3114	Fruit and Vegetable Preserving and Specialty Food Manufacturing	684	\$1,719,652	4,101	372
3115	Dairy Product Manufacturing	620	\$2,180,692	3,632	262
3116	Animal Slaughtering and Processing	2,262	\$1,396,308	12,186	648
3117	Seafood Product Preparation and Packaging	351	\$2,035,162	2,058	104

Table V-3
Profile of General Industry Very Small Business Entities (Fewer Than 20 Employees) Covered by the Final Standard
for Subparts D and I (continued)

NAICS	NAICS Description	Entities[a]	Average Receipts per Entity[b]	Total Employees	Estimated Employment in At-Risk Production Occupations (Construction, Installation, Maintenance, and Repair Occupations)[c]
3118	Bakeries and Tortilla Manufacturing	7,651	\$425,396	43,654	1,843
3119	Other Food Manufacturing	1,786	\$1,609,700	10,306	608
3121	Beverage Manufacturing	2,722	\$1,051,299	12,874	1,084
3122	Tobacco Manufacturing	40	\$5,255,550	158	23
3131	Fiber, Yarn, and Thread Mills	172	\$941,680	872	114
3132	Fabric Mills	704	\$1,069,004	4,007	382
3133	Textile and Fabric Finishing and Fabric Coating Mills	942	\$1,028,120	5,000	236
3141	Textile Furnishings Mills	2,053	\$587,568	9,147	491
3149	Other Textile Product Mills	3,302	\$544,186	16,477	708
3151	Apparel Knitting Mills	283	\$845,307	1,645	126
3152	Cut and Sew Apparel Manufacturing	7,163	\$650,130	35,018	304
3159	Apparel Accessories and Other Apparel Manufacturing	730	\$473,908	3,148	57
3161	Leather and Hide Tanning and Finishing	186	\$638,801	885	41
3162	Footwear Manufacturing	206	\$714,306	977	22
3169	Other Leather and Allied Product Manufacturing	682	\$533,997	3,201	29
3211	Sawmills and Wood Preservation	2,626	\$1,078,822	16,671	1,317
3212	Veneer, Plywood, and Engineered Wood Product Manufacturing	735	\$1,125,005	5,685	579
3219	Other Wood Product Manufacturing	6,913	\$795,184	40,335	5,009
3221	Pulp, Paper, and Paperboard Mills	85	\$2,015,788	445	82

Table V-3
Profile of General Industry Very Small Business Entities (Fewer Than 20 Employees) Covered by the Final Standard
for Subparts D and I (continued)

NAICS	NAICS Description	Entities[a]	Average Receipts per Entity[b]	Total Employees	Estimated Employment in At-Risk Production Occupations (Construction, Installation, Maintenance, and Repair Occupations)[c]
3222	Converted Paper Product Manufacturing	1,434	\$1,708,330	10,430	655
3231	Printing and Related Support Activities	26,396	\$574,129	134,736	2,159
3241	Petroleum and Coal Products Manufacturing	696	\$3,779,618	3,699	538
3251	Basic Chemical Manufacturing	753	\$3,960,376	3,914	471
3252	Resin, Synthetic Rubber, and Artificial Synthetic Fibers and Filaments Manufacturing	356	\$3,619,904	2,238	284
3253	Pesticide, Fertilizer, and Other Agricultural Chemical Manufacturing	445	\$2,637,229	2,609	323
3254	Pharmaceutical and Medicine Manufacturing	852	\$2,051,926	4,712	213
3255	Paint, Coating, and Adhesive Manufacturing	1,009	\$1,699,239	6,437	262
3256	Soap, Cleaning Compound, and Toilet Preparation Manufacturing	1,419	\$3,140,786	8,242	556
3259	Other Chemical Product and Preparation Manufacturing	1,476	\$1,538,043	8,546	550
3261	Plastics Product Manufacturing	5,175	\$1,232,932	35,604	1,974
3262	Rubber Product Manufacturing	961	\$1,057,482	6,139	393
3271	Clay Product and Refractory Manufacturing	991	\$567,411	4,380	346
3272	Glass and Glass Product Manufacturing	1,403	\$723,139	6,383	601
3273	Cement and Concrete Product Manufacturing	3,200	\$1,464,123	22,308	3,317
3274	Lime and Gypsum Product Manufacturing	150	\$1,663,193	837	153

Table V-3
Profile of General Industry Very Small Business Entities (Fewer Than 20 Employees) Covered by the Final Standard
for Subparts D and I (continued)

NAICS	NAICS Description	Entities[a]	Average Receipts per Entity[b]	Total Employees	Estimated Employment in At-Risk Production Occupations (Construction, Installation, Maintenance, and Repair Occupations)[c]
3279	Other Nonmetallic Mineral Product Manufacturing	2,199	\$948,698	13,566	1,773
3311	Iron and Steel Mills and Ferroalloy Manufacturing	532	\$3,865,032	2,441	501
3312	Steel Product Manufacturing from Purchased Steel	278	\$2,364,662	1,462	130
3313	Alumina and Aluminum Production and Processing	220	\$3,096,368	1,227	184
3314	Nonferrous Metal (except Aluminum) Production and Processing	420	\$3,356,624	2,483	254
3315	Foundries	945	\$1,085,725	6,505	539
3321	Forging and Stamping	1,237	\$1,276,886	9,085	534
3322	Cutlery and Handtool Manufacturing	982	\$850,886	5,725	222
3323	Architectural and Structural Metals Manufacturing	8,801	\$1,055,227	55,465	5,226
3324	Boiler, Tank, and Shipping Container Manufacturing	650	\$1,431,457	4,364	N/A
3325	Hardware Manufacturing	425	\$1,232,386	2,633	93
3326	Spring and Wire Product Manufacturing	918	\$971,629	6,106	212
3327	Machine Shops; Turned Product; and Screw, Nut, and Bolt Manufacturing	19,866	\$678,530	113,258	2,788
3328	Coating, Engraving, Heat Treating, and Allied Activities	3,891	\$922,584	26,405	1,085
3329	Other Fabricated Metal Product Manufacturing	3,914	\$978,226	23,158	1,323
3331	Agriculture, Construction, and Mining Machinery Manufacturing	1,698	\$1,422,711	10,869	594
3332	Industrial Machinery Manufacturing	2,406	\$1,079,228	15,172	739
3333	Commercial and Service Industry Machinery Manufacturing	1,427	\$1,193,423	8,128	416

Table V-3
Profile of General Industry Very Small Business Entities (Fewer Than 20 Employees) Covered by the Final Standard
for Subparts D and I (continued)

NAICS	NAICS Description	Entities[a]	Average Receipts per Entity[b]	Total Employees	Estimated Employment in At-Risk Production Occupations (Construction, Installation, Maintenance, and Repair Occupations)[c]
3334	Ventilation, Heating, Air-Conditioning, and Commercial Refrigeration Equipment Manufacturing	852	\$1,747,004	5,334	459
3335	Metalworking Machinery Manufacturing	5,710	\$790,926	36,628	950
3336	Engine, Turbine, and Power Transmission Equipment Manufacturing	412	\$1,638,010	2,727	218
3339	Other General Purpose Machinery Manufacturing	3,478	\$1,289,752	22,932	1,318
3341	Computer and Peripheral Equipment Manufacturing	861	\$1,376,239	4,513	96
3342	Communications Equipment Manufacturing	970	\$1,252,311	5,710	223
3343	Audio and Video Equipment Manufacturing	386	\$2,940,404	2,011	60
3344	Semiconductor and Other Electronic Component Manufacturing	2,340	\$1,138,233	15,030	438
3345	Navigational, Measuring, Electromedical, and Control Instruments Manufacturing	3,011	\$1,148,847	16,910	518
3346	Manufacturing and Reproducing Magnetic and Optical Media	604	\$782,482	2,801	120
3351	Electric Lighting Equipment Manufacturing	739	\$1,024,417	4,387	218
3352	Household Appliance Manufacturing	182	\$1,184,984	825	36
3353	Electrical Equipment Manufacturing	1,349	\$1,193,299	8,138	374
3359	Other Electrical Equipment and Component Manufacturing	1,053	\$1,326,520	6,651	303
3361	Motor Vehicle Manufacturing	199	\$3,386,462	905	92
3362	Motor Vehicle Body and Trailer Manufacturing	1,099	\$1,198,110	7,250	504

Table V-3
Profile of General Industry Very Small Business Entities (Fewer Than 20 Employees) Covered by the Final Standard
for Subparts D and I (continued)

NAICS	NAICS Description	Entities[a]	Average Receipts per Entity[b]	Total Employees	Estimated Employment in At-Risk Production Occupations (Construction, Installation, Maintenance, and Repair Occupations)[c]
3363	Motor Vehicle Parts Manufacturing	2,604	\$1,207,262	14,351	1,109
3364	Aerospace Product and Parts Manufacturing	778	\$1,223,792	4,623	473
3365	Railroad Rolling Stock Manufacturing	78	\$2,292,641	526	82
3366	Ship and Boat Building	1,132	\$805,729	5,713	1,099
3369	Other Transportation Equipment Manufacturing	787	\$1,106,198	3,625	216
3371	Household and Institutional Furniture and Kitchen Cabinet Manufacturing	13,942	\$507,009	68,572	4,303
3372	Office Furniture (including Fixtures) Manufacturing	2,542	\$860,408	16,306	823
3379	Other Furniture Related Product Manufacturing	599	\$831,331	3,500	113
3391	Medical Equipment and Supplies Manufacturing	9,679	\$514,433	41,402	932
3399	Other Miscellaneous Manufacturing	15,011	\$680,473	75,533	3,556
4231	Motor Vehicle and Motor Vehicle Parts and Supplies Merchant Wholesalers	14,357	\$2,329,990	67,329	9,711
4232	Furniture and Home Furnishing Merchant Wholesalers	9,080	\$2,011,243	41,180	1,076
4233	Lumber and Other Construction Materials Merchant Wholesalers	10,114	\$2,564,331	50,993	2,688
4234	Professional and Commercial Equipment and Supplies Merchant Wholesalers	22,167	\$1,751,265	100,895	10,378
4235	Metal and Mineral (except Petroleum) Merchant Wholesalers	5,660	\$5,805,661	29,892	811

Table V-3
Profile of General Industry Very Small Business Entities (Fewer Than 20 Employees) Covered by the Final Standard
for Subparts D and I (continued)

NAICS	NAICS Description	Entities[a]	Average Receipts per Entity[b]	Total Employees	Estimated Employment in At-Risk Production Occupations (Construction, Installation, Maintenance, and Repair Occupations)[c]
4236	Electrical and Electronic Goods Merchant Wholesalers	16,343	\$2,845,987	79,520	5,831
4237	Hardware, and Plumbing and Heating Equipment and Supplies Merchant Wholesalers	8,995	\$2,125,415	48,855	3,657
4238	Machinery, Equipment, and Supplies Merchant Wholesalers	35,458	\$2,269,440	183,385	36,887
4239	Miscellaneous Durable Goods Merchant Wholesalers	27,588	\$2,304,796	108,172	5,692
4241	Paper and Paper Product Merchant Wholesalers	7,623	\$1,826,344	35,480	463
4242	Drugs and Druggists' Sundries Merchant Wholesalers	5,110	\$2,278,428	21,652	155
4243	Apparel, Piece Goods, and Notions Merchant Wholesalers	13,010	\$2,094,234	51,757	184
4244	Grocery and Related Product Wholesalers	22,501	\$3,596,083	102,085	2,361
4245	Farm Product Raw Material Merchant Wholesalers	3,154	\$7,970,817	17,059	362
4246	Chemical and Allied Products Merchant Wholesalers	6,866	\$3,246,561	31,459	1,286
4247	Petroleum and Petroleum Products Merchant Wholesalers	3,322	\$13,682,888	18,347	1,145
4248	Beer, Wine, and Distilled Alcoholic Beverage Merchant Wholesalers	2,034	\$2,522,152	10,430	131
4249	Miscellaneous Nondurable Goods Merchant Wholesalers	22,114	\$1,932,719	89,342	1,460
4251	Wholesale Electronic Markets and Agents and Brokers	51,680	\$4,621,845	143,593	5,629
4411	Automobile Dealers	31,917	\$2,410,982	134,933	34,221
4412	Other Motor Vehicle Dealers	13,141	\$1,868,530	66,358	19,975
4413	Automotive Parts, Accessories, and Tire Stores	30,240	\$790,790	148,766	47,519

Table V-3
Profile of General Industry Very Small Business Entities (Fewer Than 20 Employees) Covered by the Final Standard
for Subparts D and I (continued)

NAICS	NAICS Description	Entities[a]	Average Receipts per Entity[b]	Total Employees	Estimated Employment in At-Risk Production Occupations (Construction, Installation, Maintenance, and Repair Occupations)[c]
4421	Furniture Stores	18,005	\$894,645	89,068	1,182
4422	Home Furnishings Stores	24,937	\$769,730	102,613	9,069
4431	Electronics and Appliance Stores	28,687	\$738,955	112,814	14,148
4441	Building Material and Supplies Dealers	38,531	\$1,159,610	215,620	8,530
4442	Lawn and Garden Equipment and Supplies Stores	14,726	\$1,074,554	73,504	7,580
4451	Grocery Stores	57,220	\$747,750	226,088	350
4452	Specialty Food Stores	21,967	\$517,551	86,699	387
4453	Beer, Wine, and Liquor Stores	26,079	\$893,894	99,028	86
4461	Health and Personal Care Stores	39,978	\$1,281,999	198,780	757
4471	Gasoline Stations	60,944	\$2,233,789	301,733	11,093
4481	Clothing Stores	38,954	\$491,851	149,900	93
4482	Shoe Stores	6,177	\$596,845	27,210	4
4483	Jewelry, Luggage, and Leather Goods Stores	18,537	\$718,611	67,338	690
4511	Sporting Goods, Hobby, and Musical Instrument Stores	30,028	\$549,951	123,641	4,654
4512	Book, Periodical, and Music Stores	8,449	\$398,946	33,123	30
4521	Department Stores	340	\$451,179	1,238	10
4529	Other General Merchandise Stores	9,408	\$467,304	35,299	580
4531	Florists	18,405	\$277,861	74,866	139
4532	Office Supplies, Stationery, and Gift Stores	27,053	\$381,300	102,946	3,228

Table V-3
Profile of General Industry Very Small Business Entities (Fewer Than 20 Employees) Covered by the Final Standard
for Subparts D and I (continued)

NAICS	NAICS Description	Entities[a]	Average Receipts per Entity[b]	Total Employees	Estimated Employment in At-Risk Production Occupations (Construction, Installation, Maintenance, and Repair Occupations)[c]
4533	Used Merchandise Stores	12,084	\$386,847	40,741	387
4539	Other Miscellaneous Store Retailers	35,066	\$784,145	129,654	6,803
4541	Electronic Shopping and Mail-Order Houses	13,757	\$1,091,352	52,575	422
4542	Vending Machine Operators	4,200	\$511,563	14,237	4,588
4543	Direct Selling Establishments	18,151	\$1,138,456	73,976	11,606
4811	Scheduled Air Transportation	375	\$1,432,816	1,508	125
4812	Nonscheduled Air Transportation	1,966	\$1,144,357	6,850	1,119
4831	Deep Sea, Coastal, and Great Lakes Water Transportation	629	\$1,863,897	2,938	85
4832	Inland Water Transportation	465	\$1,045,996	1,981	60
4841	General Freight Trucking	53,000	\$540,630	160,861	7,636
4842	Specialized Freight Trucking	43,755	\$559,392	157,509	8,618
4851	Urban Transit Systems	408	\$417,904	1,958	211
4852	Interurban and Rural Bus Transportation	156	\$459,436	663	41
4853	Taxi and Limousine Service	6,692	\$317,354	23,874	603
4854	School and Employee Bus Transportation	2,107	\$244,992	11,254	387
4855	Charter Bus Industry	776	\$535,240	4,470	254
4859	Other Transit and Ground Passenger Transportation	2,464	\$330,092	11,861	354
4861	Pipeline Transportation of Crude Oil	28	\$1,551,464	0	N/A
4862	Pipeline Transportation of Natural Gas	63	\$916,556	231	47

Table V-3
Profile of General Industry Very Small Business Entities (Fewer Than 20 Employees) Covered by the Final Standard
for Subparts D and I (continued)

NAICS	NAICS Description	Entities[a]	Average Receipts per Entity[b]	Total Employees	Estimated Employment in At-Risk Production Occupations (Construction, Installation, Maintenance, and Repair Occupations)[c]
4869	Other Pipeline Transportation	35	\$2,214,257	0	N/A
4871	Scenic and Sightseeing Transportation, Land	536	\$449,235	0	N/A
4872	Scenic and Sightseeing Transportation, Water	1,717	\$369,853	4,229	107
4879	Scenic and Sightseeing Transportation, Other	171	\$565,269	0	N/A
4881	Support Activities for Air Transportation	3,385	\$670,672	15,022	4,227
4882	Support Activities for Rail Transportation	335	\$1,056,352	2,008	679
4883	Support Activities for Water Transportation	1,404	\$842,933	5,293	327
4884	Support Activities for Road Transportation	8,660	\$412,065	36,483	1,993
4885	Freight Transportation Arrangement	11,567	\$1,169,068	49,202	481
4889	Other Support Activities for Transportation	1,381	\$483,409	4,962	151
4921	Couriers	3,321	\$470,152	11,293	279
4922	Local Messengers and Local Delivery	3,918	\$420,901	13,561	44
4931	Warehousing and Storage	3,827	\$978,953	19,343	608
5111	Newspaper, Periodical, Book, and Directory Publishers	14,080	\$636,747	63,758	516
5112	Software Publishers	4,524	\$944,289	22,363	149
5121	Motion Picture and Video Industries	16,359	\$685,625	45,008	384
5122	Sound Recording Industries	3,425	\$482,983	8,858	92
5151	Radio and Television Broadcasting	3,621	\$540,364	22,753	249
5152	Cable and Other Subscription Programming	293	\$1,520,055	1,298	348

Table V-3
Profile of General Industry Very Small Business Entities (Fewer Than 20 Employees) Covered by the Final Standard
for Subparts D and I (continued)

NAICS	NAICS Description	Entities[a]	Average Receipts per Entity[b]	Total Employees	Estimated Employment in At-Risk Production Occupations (Construction, Installation, Maintenance, and Repair Occupations)[c]
5161	Internet Publishing and Broadcasting	2,074	\$646,030	6,667	N/A
5171	Wired Telecommunications Carriers	1,393	\$1,389,149	6,875	2,320
5172	Wireless Telecommunications Carriers (except Satellite)	1,452	\$842,178	5,268	294
5173	Telecommunications Resellers	2,789	\$1,186,366	10,731	N/A
5174	Satellite Telecommunications	478	\$1,141,295	1,823	284
5175	Cable and Other Program Distribution	802	\$952,906	3,476	N/A
5179	Other Telecommunications	1,176	\$779,734	4,168	919
5181	Internet Service Providers and Web Search Portals	3,350	\$648,603	11,712	N/A
5182	Data Processing, Hosting, and Related Services	6,048	\$756,550	25,507	337
5191	Other Information Services	2,988	\$380,189	12,905	52
5211	Monetary Authorities - Central Bank	39	\$1,627,718	229	5
5221	Depository Credit Intermediation	7,589	\$1,357,749	54,220	102
5222	Nondepository Credit Intermediation	20,967	\$719,656	71,025	121
5223	Activities Related to Credit Intermediation	26,119	\$434,504	87,574	259
5231	Securities and Commodity Contracts Intermediation and Brokerage	12,049	\$1,066,412	35,583	34
5232	Securities and Commodity Exchanges	107	\$2,388,383	235	4
5239	Other Financial Investment Activities	42,067	\$925,317	113,019	292
5241	Insurance Carriers	6,199	\$1,205,802	23,179	66

Table V-3
Profile of General Industry Very Small Business Entities (Fewer Than 20 Employees) Covered by the Final Standard
for Subparts D and I (continued)

NAICS	NAICS Description	Entities[a]	Average Receipts per Entity[b]	Total Employees	Estimated Employment in At-Risk Production Occupations (Construction, Installation, Maintenance, and Repair Occupations)[c]
5242	Agencies, Brokerages, and Other Insurance Related Activities	126,015	\$405,901	401,572	487
5259	Other Investment Pools and Funds	1,965	\$2,111,505	4,448	55
5311	Lessors of Real Estate	91,585	\$686,318	259,246	69,053
5312	Offices of Real Estate Agents and Brokers	100,495	\$490,242	202,863	13,555
5313	Activities Related to Real Estate	68,879	\$387,554	204,255	40,327
5321	Automotive Equipment Rental and Leasing	4,140	\$751,836	14,057	1,855
5322	Consumer Goods Rental	10,893	\$348,975	47,138	1,429
5323	General Rental Centers	2,867	\$642,647	14,229	2,240
5324	Commercial and Industrial Machinery and Equipment Rental and Leasing	7,207	\$990,733	29,875	7,714
5331	Lessors of Nonfinancial Intangible Assets (except Copyrighted Works)	2,051	\$1,559,166	7,407	80
5411	Legal Services	173,334	\$498,006	561,904	269
5412	Accounting, Tax Preparation, Bookkeeping, and Payroll Services	101,937	\$304,149	345,607	1,903
5413	Architectural, Engineering, and Related Services	90,424	\$550,511	353,781	14,799
5414	Specialized Design Services	33,480	\$503,875	89,625	1,460
5415	Computer Systems Design and Related Services	96,593	\$491,452	258,264	4,304
5416	Management, Scientific, and Technical Consulting Services	136,280	\$460,433	312,615	7,845

**Table V-3
Profile of General Industry Very Small Business Entities (Fewer Than 20 Employees) Covered by the Final Standard
for Subparts D and I (continued)**

NAICS	NAICS Description	Entities[a]	Average Receipts per Entity[b]	Total Employees	Estimated Employment in At-Risk Production Occupations (Construction, Installation, Maintenance, and Repair Occupations)[c]
5417	Scientific Research and Development Services	10,974	\$788,491	43,789	834
5418	Advertising and Related Services	33,795	\$757,078	118,339	1,945
5419	Other Professional, Scientific, and Technical Services	59,528	\$481,878	251,956	1,734
5511	Management of Companies and Enterprises	5,719	\$1,743,093	14,633	411
5611	Office Administrative Services	22,481	\$639,205	78,740	1,871
5612	Facilities Support Services	978	\$1,047,835	4,292	562
5613	Employment Services	14,288	\$449,522	60,685	4,300
5614	Business Support Services	25,890	\$433,515	100,431	586
5615	Travel Arrangement and Reservation Services	15,806	\$433,715	54,230	369
5616	Investigation and Security Services	16,410	\$386,926	68,170	4,863
5617	Services to Buildings and Dwellings	160,667	\$289,741	546,830	17,106
5619	Other Support Services	16,611	\$692,660	63,972	3,814
5621	Waste Collection	6,550	\$763,380	33,154	2,989
5622	Waste Treatment and Disposal	1,277	\$1,043,285	6,779	1,191
5629	Remediation and Other Waste Management Services	6,739	\$654,417	31,315	16,314
6111	Elementary and Secondary Schools	8,116	\$482,773	62,969	734
6112	Junior Colleges	176	\$706,528	898	16
6113	Colleges, Universities, and Professional Schools	868	\$696,187	4,333	112
6114	Business Schools and Computer and Management Training	6,367	\$498,411	20,232	142

Table V-3
Profile of General Industry Very Small Business Entities (Fewer Than 20 Employees) Covered by the Final Standard
for Subparts D and I (continued)

NAICS	NAICS Description	Entities[a]	Average Receipts per Entity[b]	Total Employees	Estimated Employment in At-Risk Production Occupations (Construction, Installation, Maintenance, and Repair Occupations)[c]
6115	Technical and Trade Schools	5,671	\$465,825	27,936	581
6116	Other Schools and Instruction	32,864	\$232,852	137,932	720
6117	Educational Support Services	5,525	\$414,953	17,452	43
6211	Offices of Physicians	173,483	\$748,931	807,231	1,447
6212	Offices of Dentists	116,943	\$663,526	680,995	342
6213	Offices of Other Health Practitioners	108,837	\$315,908	371,257	395
6214	Outpatient Care Centers	9,406	\$662,078	49,633	334
6215	Medical and Diagnostic Laboratories	6,099	\$956,341	27,484	60
6216	Home Health Care Services	9,898	\$358,422	45,903	56
6219	Other Ambulatory Health Care Services	4,056	\$533,988	22,677	268
6221	General Medical and Surgical Hospitals	170	\$2,036,565	466	6
6222	Psychiatric and Substance Abuse Hospitals	95	\$799,389	367	8
6223	Specialty (except Psychiatric and Substance Abuse) Hospitals	236	\$699,254	727	9
6231	Nursing Care Facilities	1,768	\$722,773	8,046	107
6232	Residential Mental Retardation, Mental Health and Substance Abuse Facilities	4,311	\$309,512	26,557	251
6233	Community Care Facilities for the Elderly	10,036	\$280,604	53,169	1,149
6239	Other Residential Care Facilities	2,018	\$317,314	13,130	186
6241	Individual and Family Services	30,530	\$361,179	144,429	718

Table V-3
Profile of General Industry Very Small Business Entities (Fewer Than 20 Employees) Covered by the Final Standard
for Subparts D and I (continued)

NAICS	NAICS Description	Entities[a]	Average Receipts per Entity[b]	Total Employees	Estimated Employment in At-Risk Production Occupations (Construction, Installation, Maintenance, and Repair Occupations)[c]
6242	Community Food and Housing, and Emergency and Other Relief Services	6,950	\$708,070	39,765	1,014
6243	Vocational Rehabilitation Services	2,096	\$449,376	10,606	118
6244	Child Day Care Services	49,092	\$178,863	281,036	574
7111	Performing Arts Companies	8,161	\$586,767	28,265	780
7112	Spectator Sports	3,798	\$581,632	12,652	733
7113	Promoters of Performing Arts, Sports, and Similar Events	5,395	\$762,802	17,541	697
7114	Agents and Managers for Artists, Athletes, Entertainers, and Other Public Figures	3,511	\$737,312	8,864	41
7115	Independent Artists, Writers, and Performers	19,734	\$571,636	31,196	652
7121	Museums, Historical Sites, and Similar Institutions	5,711	\$380,010	23,753	874
7131	Amusement Parks and Arcades	2,108	\$418,728	9,002	537
7132	Gambling Industries	1,466	\$811,623	8,535	260
7139	Other Amusement and Recreation Industries	50,769	\$331,215	226,514	9,056
7211	Traveler Accommodation	33,973	\$494,261	189,353	8,638
7212	RV (Recreational Vehicle) Parks and Recreational Camps	6,233	\$434,492	18,918	2,464
7213	Rooming and Boarding Houses	2,034	\$296,352	7,687	382
7221	Full-Service Restaurants	141,430	\$325,251	867,052	645
7222	Limited-Service Eating Places	141,803	\$289,576	772,741	827

Table V-3
Profile of General Industry Very Small Business Entities (Fewer Than 20 Employees) Covered by the Final Standard
for Subparts D and I (continued)

NAICS	NAICS Description	Entities[a]	Average Receipts per Entity[b]	Total Employees	Estimated Employment in At-Risk Production Occupations (Construction, Installation, Maintenance, and Repair Occupations)[c]
7223	Special Food Services	12,836	\$338,699	53,511	539
7224	Drinking Places (Alcoholic Beverages)	42,226	\$261,017	191,304	375
8111	Automotive Repair and Maintenance	146,321	\$419,387	565,789	293,668
8112	Electronic and Precision Equipment Repair and Maintenance	10,607	\$453,389	36,870	19,190
8113	Commercial and Industrial Machinery and Equipment (except Automotive and Electronic) Repair and Maintenance	20,429	\$561,565	81,682	39,887
8114	Personal and Household Goods Repair and Maintenance	21,460	\$274,609	60,015	22,642
8121	Personal Care Services	92,503	\$163,221	339,470	203
8122	Death Care Services	14,826	\$572,485	71,093	823
8123	Dry-cleaning and Laundry Services	31,666	\$233,543	131,482	2,615
8129	Other Personal Services	24,514	\$262,944	79,248	1,058
8131	Religious Organizations	162,152	\$304,854	758,061	20,924
8132	Grantmaking and Giving Services	14,131	\$2,657,994	51,941	240
8133	Social Advocacy Organizations	11,696	\$528,285	51,251	646
8134	Civic and Social Organizations	24,642	\$336,464	113,181	1,172
8139	Business, Professional, Labor, Political, and Similar Organizations	56,541	\$514,115	235,299	10,219
	Totals	4,651,919		18,951,336	1,064,423

[a] U.S. Census Bureau, Statistics of U.S. Businesses, 2007.

Table V-3
Profile of General Industry Very Small Business Entities (Fewer Than 20 Employees) Covered by the Final Standard
for Subparts D and I (continued)

NAICS	NAICS Description	Entities[a]	Average Receipts per Entity[b]	Total Employees	Estimated Employment in At-Risk Production Occupations (Construction, Installation, Maintenance, and Repair Occupations)[c]
-------	-------------------	-------------	-----------------------------------	--------------------	--

[b] Estimated based on U.S. Census Bureau, Statistics of U.S. Businesses, 2007.

[c] Based on Bureau of Labor Statistics, Occupational Employment Statistics, 2007. Assumes the same share of at-risk production workers in construction, installation, maintenance, and repair occupations as derived for the PEA.

NA: Data not available.

Source: U.S. Department of Labor, OSHA, Directorate of Standards and Guidance, Office of Regulatory Analysis-Safety.

4. Number of Employees Using Fall Protection

Based on analysis by ERG (2007), OSHA estimated the numbers of employees using fall protection equipment by extrapolating results obtained from OSHA's 1999 PPE Cost Survey.¹⁰⁵ This establishment-based survey provided industry-specific estimates of the numbers of workers who used various types of personal fall protection equipment, including body harnesses and body belts. The survey reported the percentage of employees in each industry (by SIC codes) who used these types of personal fall protection equipment. ERG applied the survey findings by first associating the SIC industries covered by the survey with the 4-digit NAICS industry codes, and then multiplying total employment (presented above in Table V-1) by the percentage of employees who used personal fall protection equipment.

Because different employees might use both body harnesses and body belts, OSHA used the combined value of the two percentages in deriving these estimates. For example, if six percent of employees in a given industry used body harnesses while four percent of employees used body belts, OSHA applied the combined percentage (ten percent) as its estimate of the maximum number of employees using either form of fall protection.¹⁰⁶ The survey's design

¹⁰⁵ For a description of the survey, see ERG (1999) in the reference section of this FEA. ERG excluded back-support belts and similar ergonomic devices from the types of personal protective equipment investigated by the survey.

¹⁰⁶ For the PEA, OSHA applied the upper value in the range—six percent in the example given—and not the combined percentage.

did not permit industry-specific estimates for all industries.

For example, only aggregated estimates are available for several groups of service, wholesale, and retail trade industries. To make the fall protection estimates consistent with the numbers of at-risk employees, OSHA constrained the estimated number of employees using personal fall protection equipment in any industry to be less than or equal to the numbers of employees in construction, installation, maintenance, and repair occupations shown in Table V-1. Table V-4 presents, by the 4-digit NAICS industry code, OSHA's estimate of the number of employees using fall protection equipment.¹⁰⁷ Overall, OSHA estimated that approximately 2.1 million employees in general industry currently use and will continue to use fall protection.

5. Wage Rates

As discussed in detail later in this FEA, OSHA believes that much of the cost impact of the final standard results from the time requirements for additional training and inspections. The Agency based the estimates for these

¹⁰⁷ The source of the data in Table V-4 is the OSHA PPE Cost Survey. Estimates shown are based on the combined percentage of employees using body harnesses and body belts. See Eastern Research Group, 1999. An "NA" indicates that the industry was not within the scope of the survey or that the subset of production employees judged to be subject to this standard was zero (NA) (see Table V-1). In ERG, 1999 (OSHA PPE Survey), see Table A2, PPE Category: Fall Protection; PPE Type: Body Harness; PPE Type: Body Belt, where, by two-, three-, and four-digit SIC codes, the number and percentage of employees using the PPE type is reported. For this FEA, ERG converted SIC codes to NAICS codes; see Ex. [OSHA Excel Workbook], tab Fall_protection.

costs on the opportunity cost of the labor time devoted to training, inspections, and installation or deployment of fall protection equipment. OSHA valued these opportunity costs in terms of employees' hourly wages, including benefit and fringe costs. Relying on average hourly earnings as reported by the BLS *Occupational Employment Statistics Survey, 2010*, OSHA constructed a weighted average hourly wage for the specific occupations comprising production employment for each industry. Similarly, OSHA constructed an average hourly production-supervisor wage for each industry.¹⁰⁸ The Agency then multiplied these wages by a mark-up factor to account for fringe benefits. According to the 2010 BLS Employer Costs for Employee Compensation¹⁰⁹ survey (BLS, 2011), this mark-up factor averages 41.5 percent across industries in 2010. The loaded wage rates applied by OSHA in this FEA are in Table V-5.

¹⁰⁸ For example, for NAICS 4871—Scenic and Sightseeing Transportation, Land, NAICS 4872—Scenic and Sightseeing Transportation, Water, and NAICS 4879—Scenic and Sightseeing Transportation, Other, BLS OES did not report production wage and supervisory wage for 2010. Therefore, OSHA's applied as the base wage for production worker (\$19.80), the reported value for the next largest available industry sector, NAICS 48-49, Transportation and Warehousing. For the supervisory wage (\$27.45) for NAICS 4871, 4872, and 4879, OSHA applied a wage rate taken from a related transportation industry, NAICS 4851, Urban Transit Systems. Applying the fringe-benefit markup factor of 41.5 percent raised the production worker wage to \$28.01 and the supervisory wage to \$38.83.

¹⁰⁹ BLS (2010) reported a value of 41.5 percent for all private industry for June 2010.

Table V-4
Estimated Number of Employees Using Fall Protection Equipment

NAICS	NAICS Description	Total Employment	Employees Using Fall Protection[a]		
			Percent	Number [c]	
1131	Timber Tract Operations	2,632	10.7%	NA	
1132	Forest Nurseries and Gathering of Forest Products	2,216	18.4%	NA	
1133	Logging	59,597	3.3%	1,954	
1141	Fishing	5,302	N/A	NA	
1142	Hunting and Trapping	1,845	N/A	NA	
1153	Support Activities for Forestry	13,740	18.4%	NA	
2111	Oil and Gas Extraction	141,809	25.0%	24,910	[b]
2211	Electric Power Generation, Transmission and Distribution	503,134	16.2%	81,340	
2212	Natural Gas Distribution	79,354	16.2%	12,829	
2213	Water, Sewage and Other Systems	40,269	16.2%	6,510	
3111	Animal Food Manufacturing	46,983	3.0%	1,411	
3112	Grain and Oilseed Milling	58,049	3.0%	1,743	
3113	Sugar and Confectionery Product Manufacturing	73,457	3.0%	2,206	
3114	Fruit and Vegetable Preserving and Specialty Food Manufacturing	162,253	3.0%	4,873	
3115	Dairy Product Manufacturing	129,692	3.0%	3,895	
3116	Animal Slaughtering and Processing	487,813	3.0%	14,650	
3117	Seafood Product Preparation and Packaging	33,169	3.0%	996	
3118	Bakeries and Tortilla Manufacturing	284,998	3.0%	8,559	
3119	Other Food Manufacturing	162,852	3.0%	4,891	
3121	Beverage Manufacturing	135,979	3.0%	4,084	
3122	Tobacco Manufacturing	20,135	3.4%	688	
3131	Fiber, Yarn, and Thread Mills	42,041	2.9%	1,213	
3132	Fabric Mills	80,514	2.9%	2,324	
3133	Textile and Fabric Finishing and Fabric Coating Mills	41,527	2.9%	1,199	
3141	Textile Furnishings Mills	80,278	2.9%	2,317	
3149	Other Textile Product Mills	72,700	2.9%	2,098	
3151	Apparel Knitting Mills	26,584	2.9%	779	
3152	Cut and Sew Apparel Manufacturing	155,742	2.9%	1,463	[b]
3159	Apparel Accessories and Other Apparel Manufacturing	15,128	2.9%	340	
3161	Leather and Hide Tanning and Finishing	4,856	2.9%	140	
3162	Footwear Manufacturing	15,017	2.9%	360	

Table V-4
Estimated Number of Employees Using Fall Protection Equipment (continued)

NAICS	NAICS Description	Total Employment	Employees Using Fall Protection[a]		
			Percent	Number[c]	
3169	Other Leather and Allied Product Manufacturing	16,798	2.9%	100	[b]
3211	Sawmills and Wood Preservation	112,425	3.3%	3,687	
3212	Veneer, Plywood, and Engineered Wood Product Manufacturing	109,002	3.3%	3,574	
3219	Other Wood Product Manufacturing	306,138	3.3%	10,039	
3221	Pulp, Paper, and Paperboard Mills	130,068	7.4%	9,625	
3222	Converted Paper Product Manufacturing	295,028	7.4%	20,140	
3231	Printing and Related Support Activities	631,771	3.4%	10,140	[b]
3241	Petroleum and Coal Products Manufacturing	103,577	17.5%	17,330	[b]
3251	Basic Chemical Manufacturing	165,025	17.9%	19,100	[b]
3252	Resin, Synthetic Rubber, and Artificial Synthetic Fibers and Filaments Manufacturing	88,601	17.9%	13,690	[b]
3253	Pesticide, Fertilizer, and Other Agricultural Chemical Manufacturing	28,618	17.9%	4,520	[b]
3254	Pharmaceutical and Medicine Manufacturing	241,339	17.9%	14,170	[b]
3255	Paint, Coating, and Adhesive Manufacturing	62,493	17.9%	2,710	[b]
3256	Soap, Cleaning Compound, and Toilet Preparation Manufacturing	104,422	17.9%	7,580	[b]
3259	Other Chemical Product and Preparation Manufacturing	103,219	17.9%	6,770	[b]
3261	Plastics Product Manufacturing	707,972	2.7%	19,284	
3262	Rubber Product Manufacturing	147,511	2.7%	4,018	
3271	Clay Product and Refractory Manufacturing	52,544	8.0%	4,192	
3272	Glass and Glass Product Manufacturing	97,876	8.0%	7,810	
3273	Cement and Concrete Product Manufacturing	221,488	8.0%	17,673	
3274	Lime and Gypsum Product Manufacturing	17,332	8.0%	1,383	
3279	Other Nonmetallic Mineral Product Manufacturing	82,888	8.0%	6,614	
3311	Iron and Steel Mills and Ferroalloy Manufacturing	109,998	8.3%	9,150	
3312	Steel Product Manufacturing from Purchased Steel	44,492	8.3%	3,701	
3313	Alumina and Aluminum Production and Processing	63,988	8.3%	5,323	
3314	Nonferrous Metal (except Aluminum) Production and Processing	60,466	8.3%	5,030	
3315	Foundries	159,977	8.3%	13,308	
3321	Forging and Stamping	124,406	2.6%	3,246	
3322	Cutlery and Handtool Manufacturing	50,529	2.6%	1,318	

Table V-4
Estimated Number of Employees Using Fall Protection Equipment (continued)

NAICS	NAICS Description	Total Employment	Employees Using Fall Protection[a]		
			Percent	Number[c]	
3323	Architectural and Structural Metals Manufacturing	398,786	2.6%	10,404	
3324	Boiler, Tank, and Shipping Container Manufacturing	93,356	2.6%	2,436	
3325	Hardware Manufacturing	41,763	2.6%	1,090	
3326	Spring and Wire Product Manufacturing	53,413	2.6%	1,394	
3327	Machine Shops; Turned Product; and Screw, Nut, and Bolt Manufacturing	395,207	2.6%	10,311	
3328	Coating, Engraving, Heat Treating, and Allied Activities	137,183	2.6%	3,579	
3329	Other Fabricated Metal Product Manufacturing	271,223	2.6%	7,076	
3331	Agriculture, Construction, and Mining Machinery Manufacturing	205,545	2.8%	5,841	
3332	Industrial Machinery Manufacturing	130,022	2.8%	3,695	
3333	Commercial and Service Industry Machinery Manufacturing	95,729	2.8%	2,720	
3334	Ventilation, Heating, Air-Conditioning, and Commercial Refrigeration Equipment Manufacturing	151,175	2.8%	4,296	
3335	Metalworking Machinery Manufacturing	167,558	2.8%	4,761	[b]
3336	Engine, Turbine, and Power Transmission Equipment Manufacturing	102,482	2.8%	2,912	
3339	Other General Purpose Machinery Manufacturing	285,029	2.8%	8,100	
3341	Computer and Peripheral Equipment Manufacturing	99,137	2.6%	2,540	[b]
3342	Communications Equipment Manufacturing	151,847	2.6%	3,891	
3343	Audio and Video Equipment Manufacturing	17,191	2.6%	441	
3344	Semiconductor and Other Electronic Component Manufacturing	362,859	2.6%	9,298	
3345	Navigational, Measuring, Electromedical, and Control Instruments Manufacturing	384,966	2.6%	9,865	
3346	Manufacturing and Reproducing Magnetic and Optical Media	27,288	2.6%	699	
3351	Electric Lighting Equipment Manufacturing	57,515	2.6%	1,474	
3352	Household Appliance Manufacturing	65,666	2.6%	1,683	
3353	Electrical Equipment Manufacturing	138,332	2.6%	3,545	
3359	Other Electrical Equipment and Component Manufacturing	144,746	2.6%	3,709	
3361	Motor Vehicle Manufacturing	196,493	2.7%	5,217	
3362	Motor Vehicle Body and Trailer Manufacturing	151,588	2.7%	4,025	
3363	Motor Vehicle Parts Manufacturing	593,630	2.7%	15,762	

Table V-4
Estimated Number of Employees Using Fall Protection Equipment (continued)

NAICS	NAICS Description	Total Employment	Employees Using Fall Protection[a]		
			Percent	Number[c]	
3364	Aerospace Product and Parts Manufacturing	408,139	2.7%	10,837	
3365	Railroad Rolling Stock Manufacturing	28,712	2.7%	762	
3366	Ship and Boat Building	148,864	39.5%	31,360	[b]
3369	Other Transportation Equipment Manufacturing	46,721	2.7%	1,241	
3371	Household and Institutional Furniture and Kitchen Cabinet Manufacturing	333,974	3.0%	10,002	
3372	Office Furniture (including Fixtures) Manufacturing	141,000	3.0%	4,223	
3379	Other Furniture Related Product Manufacturing	42,427	3.0%	1,271	
3391	Medical Equipment and Supplies Manufacturing	316,789	2.6%	7,210	[b]
3399	Other Miscellaneous Manufacturing	364,059	3.0%	10,907	
4231	Motor Vehicle and Motor Vehicle Parts and Supplies Merchant Wholesalers	355,828	8.2%	29,089	
4232	Furniture and Home Furnishing Merchant Wholesalers	153,866	8.2%	3,320	[b]
4233	Lumber and Other Construction Materials Merchant Wholesalers	264,252	8.2%	14,470	
4234	Professional and Commercial Equipment and Supplies Merchant Wholesalers	705,551	8.2%	57,678	
4235	Metal and Mineral (except Petroleum) Merchant Wholesalers	160,366	8.2%	3,670	[b]
4236	Electrical and Electronic Goods Merchant Wholesalers	449,905	8.2%	25,160	
4237	Hardware, and Plumbing and Heating Equipment and Supplies Merchant Wholesalers	232,006	8.2%	17,670	
4238	Machinery, Equipment, and Supplies Merchant Wholesalers	723,802	8.2%	59,170	
4239	Miscellaneous Durable Goods Merchant Wholesalers	349,701	8.2%	13,550	
4241	Paper and Paper Product Merchant Wholesalers	172,308	7.2%	1,920	[b]
4242	Drugs and Druggists' Sundries Merchant Wholesalers	248,057	7.2%	1,600	[b]
4243	Apparel, Piece Goods, and Notions Merchant Wholesalers	196,601	7.2%	490	[b]
4244	Grocery and Related Product Wholesalers	768,342	7.2%	17,420	[b]
4245	Farm Product Raw Material Merchant Wholesalers	61,349	7.2%	1,720	[b]
4246	Chemical and Allied Products Merchant Wholesalers	139,481	7.2%	6,020	[b]
4247	Petroleum and Petroleum Products Merchant Wholesalers	94,845	7.2%	6,050	
4248	Beer, Wine, and Distilled Alcoholic Beverage Merchant Wholesalers	178,694	7.2%	1,870	[b]
4249	Miscellaneous Nondurable Goods Merchant	368,372	7.2%	5,970	[b]

Table V-4
Estimated Number of Employees Using Fall Protection Equipment (continued)

NAICS	NAICS Description	Total Employment	Employees Using Fall Protection[a]		
			Percent	Number[c]	
	Wholesalers				
4251	Wholesale Electronic Markets and Agents and Brokers	341,524	7.2%	24,451	[b]
4411	Automobile Dealers	1,273,660	3.0%	38,408	
4412	Other Motor Vehicle Dealers	168,973	3.0%	5,096	
4413	Automotive Parts, Accessories, and Tire Stores	495,633	3.0%	14,946	
4421	Furniture Stores	271,675	4.2%	4,160	[b]
4422	Home Furnishings Stores	324,863	4.2%	13,722	
4431	Electronics and Appliance Stores	500,780	4.2%	21,152	
4441	Building Material and Supplies Dealers	1,202,392	3.8%	45,188	
4442	Lawn and Garden Equipment and Supplies Stores	171,569	3.8%	6,448	
4451	Grocery Stores	2,564,533	3.2%	3,590	[b]
4452	Specialty Food Stores	174,558	3.2%	1,510	[b]
4453	Beer, Wine, and Liquor Stores	142,692	3.2%	160	[b]
4461	Health and Personal Care Stores	1,069,187	3.2%	3,760	[b]
4471	Gasoline Stations	888,705	3.2%	28,183	
4481	Clothing Stores	1,278,939	4.3%	820	[b]
4482	Shoe Stores	206,338	4.3%	0	[b]
4483	Jewelry, Luggage, and Leather Goods Stores	162,880	4.3%	1,690	[b]
4511	Sporting Goods, Hobby, and Musical Instrument Stores	455,576	4.3%	17,950	
4512	Book, Periodical, and Music Stores	184,118	4.3%	200	[b]
4521	Department Stores	1,619,833	2.7%	14,480	[b]
4529	Other General Merchandise Stores	1,277,639	2.7%	24,990	[b]
4531	Florists	93,779	2.7%	190	[b]
4532	Office Supplies, Stationery, and Gift Stores	315,159	2.7%	8,418	
4533	Used Merchandise Stores	133,918	4.2%	1,090	[b]
4539	Other Miscellaneous Store Retailers	270,971	4.2%	11,258	
4541	Electronic Shopping and Mail-Order Houses	268,328	4.2%	2,460	[b]
4542	Vending Machine Operators	49,446	4.2%	2,054	
4543	Direct Selling Establishments	193,784	4.2%	8,051	
4811	Scheduled Air Transportation	435,853	10.1%	38,230	
4812	Nonscheduled Air Transportation	44,795	10.1%	4,508	
4831	Deep Sea, Coastal, and Great Lakes Water Transportation	48,180	10.1%	450	[b]

Table V-4
Estimated Number of Employees Using Fall Protection Equipment (continued)

NAICS	NAICS Description	Total Employment	Employees Using Fall Protection[a]		
			Percent	Number[c]	
4832	Inland Water Transportation	20,767	6.3%	540	[b]
4841	General Freight Trucking	998,697	6.7%	48,700	
4842	Specialized Freight Trucking	477,700	6.7%	24,240	
4851	Urban Transit Systems	52,912	4.4%	2,329	
4852	Interurban and Rural Bus Transportation	17,432	4.4%	767	
4853	Taxi and Limousine Service	72,504	4.4%	1,610	[b]
4854	School and Employee Bus Transportation	206,787	4.4%	6,700	
4855	Charter Bus Industry	28,384	4.4%	1,249	
4859	Other Transit and Ground Passenger Transportation	62,604	4.4%	1,530	
4861	Pipeline Transportation of Crude Oil	8,347	14.5%	1,214	
4862	Pipeline Transportation of Natural Gas	24,683	14.5%	3,589	
4869	Other Pipeline Transportation	9,415	14.5%	1,000	
4871	Scenic and Sightseeing Transportation, Land	9,690	NA	NA	
4872	Scenic and Sightseeing Transportation, Water	15,612	NA	NA	
4879	Scenic and Sightseeing Transportation, Other	2,162	NA	NA	
4881	Support Activities for Air Transportation	3,676	6.0%	220	
4882	Support Activities for Rail Transportation	308	6.0%	18	
4883	Support Activities for Water Transportation	1,442	15.2%	219	[b]
4884	Support Activities for Road Transportation	9,719	6.0%	580	
4885	Freight Transportation Arrangement	212,165	6.0%	1,820	[b]
4889	Other Support Activities for Transportation	34,654	6.0%	930	[b]
4921	Couriers	528,177	6.0%	13,900	[b]
4922	Local Messengers and Local Delivery	41,013	6.0%	220	[b]
4931	Warehousing and Storage	679,077	6.7%	21,630	[b]
5111	Newspaper, Periodical, Book, and Directory Publishers	688,034	3.4%	5,780	[b]
5112	Software Publishers	346,675	1.3%	1,780	[b]
5121	Motion Picture and Video Industries	298,598	N/A	N/A	
5122	Sound Recording Industries	22,049	15.5%	150	[b]
5151	Radio and Television Broadcasting	252,294	15.5%	2,860	[b]
5152	Cable and Other Subscription Programming	41,674	15.5%	6,471	
5161	Internet Publishing and Broadcasting	46,627	NA	NA	
5171	Wired Telecommunications Carriers	621,712	15.5%	96,533	
5172	Wireless Telecommunications Carriers (except	277,622	15.5%	11,410	[b]

Table V-4
Estimated Number of Employees Using Fall Protection Equipment (continued)

NAICS	NAICS Description	Total Employment	Employees Using Fall Protection[a]		
			Percent	Number[c]	
	Satellite)				
5173	Telecommunications Resellers	34,973	15.5%	5,430	
5174	Satellite Telecommunications	13,149	15.5%	2,042	
5175	Cable and Other Program Distribution	240,038	NA	NA	
5179	Other Telecommunications	14,428	NA	NA	
5181	Internet Service Providers and Web Search Portals	71,307	NA	NA	
5182	Data Processing, Hosting, and Related Services	375,474	NA	NA	
5191	Other Information Services	54,659	NA	NA	
5211	Monetary Authorities - Central Bank	20,223	NA	NA	
5221	Depository Credit Intermediation	2,137,764	NA	NA	
5222	Nondepository Credit Intermediation	747,414	NA	NA	
5223	Activities Related to Credit Intermediation	341,041	NA	NA	
5231	Securities and Commodity Contracts Intermediation and Brokerage	528,722	NA	NA	
5232	Securities and Commodity Exchanges	8,600	NA	NA	
5239	Other Financial Investment Activities	404,402	NA	NA	
5241	Insurance Carriers	1,423,578	1.6%	3,700	[b]
5242	Agencies, Brokerages, and Other Insurance Related Activities	903,366	1.6%	1,270	[b]
5259	Other Investment Pools and Funds	33,396	1.6%	520	
5311	Lessors of Real Estate	539,169	1.6%	8,393	
5312	Offices of Real Estate Agents and Brokers	367,125	1.6%	5,715	
5313	Activities Related to Real Estate	647,869	1.6%	10,086	
5321	Automotive Equipment Rental and Leasing	199,872	1.6%	3,111	
5322	Consumer Goods Rental	237,074	1.6%	3,691	
5323	General Rental Centers	35,493	1.6%	553	
5324	Commercial and Industrial Machinery and Equipment Rental and Leasing	165,838	1.6%	2,582	
5331	Lessors of Nonfinancial Intangible Assets (except Copyrighted Works)	31,735	1.6%	250	
5411	Legal Services	1,206,577	1.6%	580	[b]
5412	Accounting, Tax Preparation, Bookkeeping, and Payroll Services	1,357,368	1.6%	5,310	[b]
5413	Architectural, Engineering, and Related Services	1,434,803	1.9%	26,805	
5414	Specialized Design Services	134,739	1.9%	2,390	

Table V-4
Estimated Number of Employees Using Fall Protection Equipment (continued)

NAICS	NAICS Description	Total Employment	Employees Using Fall Protection[a]		
			Percent	Number[c]	
5415	Computer Systems Design and Related Services	1,297,710	1.9%	22,640	
5416	Management, Scientific, and Technical Consulting Services	1,015,109	1.9%	18,965	
5417	Scientific Research and Development Services	688,052	1.9%	11,360	
5418	Advertising and Related Services	445,590	1.9%	8,000	
5419	Other Professional, Scientific, and Technical Services	599,993	1.9%	3,830	[b]
5511	Management of Companies and Enterprises	3,121,402	1.6%	48,592	
5611	Office Administrative Services	472,690	1.6%	7,359	
5612	Facilities Support Services	189,275	1.6%	2,947	
5613	Employment Services	5,131,446	1.6%	79,883	
5614	Business Support Services	766,237	1.6%	3,890	[b]
5615	Travel Arrangement and Reservation Services	243,943	1.6%	1,270	[b]
5616	Investigation and Security Services	777,680	1.6%	12,106	
5617	Services to Buildings and Dwellings	1,722,595	1.6%	26,816	
5619	Other Support Services	324,602	1.6%	5,053	
5621	Waste Collection	185,047	1.6%	2,881	
5622	Waste Treatment and Disposal	56,755	1.6%	884	
5629	Remediation and Other Waste Management Services	113,391	1.6%	1,765	
6111	Elementary and Secondary Schools	827,165	NA	NA	
6112	Junior Colleges	80,568	NA	NA	
6113	Colleges, Universities, and Professional Schools	1,572,333	NA	NA	
6114	Business Schools and Computer and Management Training	65,818	NA	NA	
6115	Technical and Trade Schools	119,020	NA	NA	
6116	Other Schools and Instruction	302,908	NA	NA	
6117	Educational Support Services	71,573	NA	NA	
6211	Offices of Physicians	2,169,682	1.5%	3,150	[b]
6212	Offices of Dentists	824,770	1.5%	520	[b]
6213	Offices of Other Health Practitioners	614,171	1.5%	600	[b]
6214	Outpatient Care Centers	695,863	1.5%	3,680	[b]
6215	Medical and Diagnostic Laboratories	221,709	1.5%	490	[b]
6216	Home Health Care Services	1,021,573	1.5%	1,190	[b]
6219	Other Ambulatory Health Care Services	269,271	1.5%	2,670	[b]

Table V-4
Estimated Number of Employees Using Fall Protection Equipment (continued)

NAICS	NAICS Description	Total Employment	Employees Using Fall Protection[a]		
			Percent	Number[c]	
6221	General Medical and Surgical Hospitals	5,041,848	1.5%	65,370	
6222	Psychiatric and Substance Abuse Hospitals	216,343	1.5%	3,242	
6223	Specialty (except Psychiatric and Substance Abuse) Hospitals	219,627	1.5%	2,520	[b]
6231	Nursing Care Facilities	1,646,321	1.5%	21,780	
6232	Residential Mental Retardation, Mental Health and Substance Abuse Facilities	557,907	1.5%	5,110	[b]
6233	Community Care Facilities for the Elderly	685,024	1.5%	10,266	
6239	Other Residential Care Facilities	153,881	1.5%	2,290	
6241	Individual and Family Services	1,108,173	1.5%	5,560	[b]
6242	Community Food and Housing, and Emergency and Other Relief Services	167,691	1.5%	2,513	
6243	Vocational Rehabilitation Services	330,145	1.5%	3,480	[b]
6244	Child Day Care Services	853,648	1.5%	1,760	[b]
7111	Performing Arts Companies	134,434	NA	NA	
7112	Spectator Sports	126,092	NA	NA	
7113	Promoters of Performing Arts, Sports, and Similar Events	112,354	N/A	N/A	
7114	Agents and Managers for Artists, Athletes, Entertainers, and Other Public Figures	17,420	NA	NA	
7115	Independent Artists, Writers, and Performers	45,772	NA	NA	
7121	Museums, Historical Sites, and Similar Institutions	128,539	NA	NA	
7131	Amusement Parks and Arcades	128,369	NA	NA	
7132	Gambling Industries	205,307	NA	NA	
7139	Other Amusement and Recreation Industries	1,110,280	NA	NA	
7211	Traveler Accommodation	1,856,110	1.3%	23,602	
7212	RV (Recreational Vehicle) Parks and Recreational Camps	39,717	1.3%	505	
7213	Rooming and Boarding Houses	11,727	1.3%	149	
7221	Full-Service Restaurants	4,579,941	3.3%	3,580	[b]
7222	Limited-Service Eating Places	4,136,741	3.3%	4,080	[b]
7223	Special Food Services	575,579	3.3%	6,610	[b]
7224	Drinking Places (Alcoholic Beverages)	365,049	3.3%	690	[b]
8111	Automotive Repair and Maintenance	893,198	4.0%	35,820	
8112	Electronic and Precision Equipment Repair and	135,243	3.4%	4,659	

Table V-4
Estimated Number of Employees Using Fall Protection Equipment (continued)

NAICS	NAICS Description	Total Employment	Employees Using Fall Protection[a]		
			Percent	Number[c]	
	Maintenance				
8113	Commercial and Industrial Machinery and Equipment (except Automotive and Electronic) Repair and Maintenance	199,239	3.4%	6,863	
8114	Personal and Household Goods Repair and Maintenance	95,272	3.4%	3,282	
8121	Personal Care Services	616,538	2.4%	420	[b]
8122	Death Care Services	136,928	2.4%	1,790	[b]
8123	Dry-cleaning and Laundry Services	374,356	2.4%	6,800	
8129	Other Personal Services	252,462	2.4%	3,680	
8131	Religious Organizations	1,691,182	1.6%	4,940	
8132	Grantmaking and Giving Services	146,709	1.6%	700	[b]
8133	Social Advocacy Organizations	128,522	1.6%	2,001	
8134	Civic and Social Organizations	330,219	1.6%	4,540	
8139	Business, Professional, Labor, Political, and Similar Organizations	519,905	1.6%	8,094	
	Totals	112,328,837	1.9%	2,113,676	

[a] Source: OSHA PPE Cost Survey. Estimate based on the combined percentage of employees using body harnesses and body belts. See Eastern Research Group, 1999. An "NA" indicates that the industry was not within the scope of the survey or that the subset of production employees judged to be subject to this standard was zero (NA) (see Table V-1). In ERG, 1999 (OSHA PPE Survey), see Table A2, PPE Category: Fall Protection; PPE Type: Body Harness; PPE Type: Body Belt, where by two-, three-, and four-digit SIC code, the number and percentage of employees using PPE type is reported. For this FEA, ERG converted SIC codes to NAICS codes; see Ex. [OSHA Excel Workbook], tab Fall_protection.

[b] Number using fall protection constrained to be less than or equal to the number of at-risk employees in construction, installation, maintenance, and repair occupations as shown in Table V-1.

[c] Due to rounding, the number shown may differ from the product of total employment multiplied by the percentage of employees using fall protection.

Source: U.S. Department of Labor, OSHA, Directorate of Standards and Guidance, Office of Regulatory Analysis, based on U.S. Census Bureau, Statistics of U.S. Businesses for 2002 and 2006; ERG, 2007; and ERG, 1999.

Table V-5
Wage Rates in Industries Affected by OSHA's Final Standard for Walking-Working Surfaces

NAICS	Industry	Production Worker Mean Hourly Wage		Production Worker Supervisor Mean Hourly Wage	
		Base Rate	With Fringe Markup	Base Rate	With Fringe Markup
1131	Timber Tract Operations	\$14.13	\$19.99	\$18.45	\$26.10
1132	Forest Nurseries and Gathering of Forest Products	\$14.13	\$19.99	\$18.45	\$26.10
1133	Logging	\$14.13	\$19.99	\$18.45	\$26.10
1141	Fishing	\$11.46	\$16.21	\$20.95	\$29.63
1142	Hunting and Trapping	\$11.46	\$16.21	\$20.95	\$29.63
1153	Support Activities for Forestry	\$11.30	\$15.98	\$21.14	\$29.90
2111	Oil and Gas Extraction	\$28.93	\$40.92	\$36.11	\$51.07
2211	Electric Power Generation, Transmission and Distribution	\$31.89	\$45.11	\$38.35	\$54.24
2212	Natural Gas Distribution	\$30.68	\$43.39	\$39.50	\$55.87
2213	Water, Sewage and Other Systems	\$21.54	\$30.47	\$29.45	\$41.65
3111	Animal Food Manufacturing	\$15.06	\$21.30	\$24.63	\$34.84
3112	Grain and Oilseed Milling	\$17.83	\$25.22	\$27.36	\$38.70
3113	Sugar and Confectionery Product Manufacturing	\$14.87	\$21.03	\$25.21	\$35.66
3114	Fruit and Vegetable Preserving and Specialty Food Manufacturing	\$14.01	\$19.82	\$24.52	\$34.68
3115	Dairy Product Manufacturing	\$16.00	\$22.63	\$25.89	\$36.62
3116	Animal Slaughtering and Processing	\$12.15	\$17.19	\$23.18	\$32.79
3117	Seafood Product Preparation and Packaging	\$11.69	\$16.53	\$23.09	\$32.66
3118	Bakeries and Tortilla Manufacturing	\$13.48	\$19.07	\$23.36	\$33.04
3119	Other Food Manufacturing	\$14.47	\$20.47	\$25.51	\$36.08
3121	Beverage Manufacturing	\$17.60	\$24.89	\$27.31	\$38.63
3122	Tobacco Manufacturing	\$19.30	\$27.30	\$27.01	\$38.20
3131	Fiber, Yarn, and Thread Mills	\$12.88	\$18.22	\$22.87	\$32.35
3132	Fabric Mills	\$14.08	\$19.92	\$23.08	\$32.64
3133	Textile and Fabric Finishing and Fabric Coating Mills	\$12.95	\$18.32	\$23.27	\$32.91
3141	Textile Furnishings Mills	\$12.96	\$18.33	\$22.64	\$32.02
3149	Other Textile Product Mills	\$12.54	\$17.74	\$21.57	\$30.51
3151	Apparel Knitting Mills	\$11.58	\$16.38	\$20.69	\$29.26

Table V-5
Wage Rates in Industries Affected by OSHA's Final Standard for Walking-Working Surfaces
(continued)

NAICS	Industry	Production Worker Mean Hourly Wage		Production Worker Supervisor Mean Hourly Wage	
		Base Rate	With Fringe Markup	Base Rate	With Fringe Markup
3152	Cut and Sew Apparel Manufacturing	\$11.56	\$16.35	\$20.29	\$28.70
3159	Apparel Accessories and Other Apparel Manufacturing	\$11.24	\$15.90	\$20.35	\$28.78
3161	Leather and Hide Tanning and Finishing	\$12.93	\$18.29	\$22.67	\$32.07
3162	Footwear Manufacturing	\$12.56	\$17.77	\$22.36	\$31.63
3169	Other Leather and Allied Product Manufacturing	\$12.28	\$17.37	\$21.61	\$30.57
3211	Sawmills and Wood Preservation	\$14.75	\$20.86	\$25.00	\$35.36
3212	Veneer, Plywood, and Engineered Wood Product Manufacturing	\$14.58	\$20.62	\$24.58	\$34.77
3219	Other Wood Product Manufacturing	\$13.75	\$19.45	\$23.04	\$32.59
3221	Pulp, Paper, and Paperboard Mills	\$21.42	\$30.30	\$33.79	\$47.79
3222	Converted Paper Product Manufacturing	\$16.87	\$23.86	\$27.57	\$39.00
3231	Printing and Related Support Activities	\$16.92	\$23.93	\$27.05	\$38.26
3241	Petroleum and Coal Products Manufacturing	\$26.69	\$37.75	\$35.71	\$50.51
3251	Basic Chemical Manufacturing	\$23.90	\$33.80	\$33.57	\$47.48
3252	Resin, Synthetic Rubber, and Artificial Synthetic Fibers and Filaments Manufacturing	\$21.52	\$30.44	\$31.99	\$45.25
3253	Pesticide, Fertilizer, and Other Agricultural Chemical Manufacturing	\$20.76	\$29.36	\$31.06	\$43.93
3254	Pharmaceutical and Medicine Manufacturing	\$17.91	\$25.33	\$30.09	\$42.56
3255	Paint, Coating, and Adhesive Manufacturing	\$17.95	\$25.39	\$29.41	\$41.60
3256	Soap, Cleaning Compound, and Toilet Preparation Manufacturing	\$16.01	\$22.64	\$27.40	\$38.76
3259	Other Chemical Product and Preparation Manufacturing	\$17.55	\$24.82	\$28.56	\$40.40
3261	Plastics Product Manufacturing	\$14.90	\$21.07	\$24.99	\$35.35
3262	Rubber Product Manufacturing	\$16.65	\$23.55	\$24.47	\$34.61
3271	Clay Product and Refractory Manufacturing	\$15.67	\$22.16	\$25.55	\$36.14
3272	Glass and Glass Product Manufacturing	\$16.49	\$23.32	\$27.37	\$38.71
3273	Cement and Concrete Product Manufacturing	\$16.44	\$23.25	\$26.92	\$38.08
3274	Lime and Gypsum Product Manufacturing	\$18.49	\$26.15	\$26.70	\$37.77

Table V-5
Wage Rates in Industries Affected by OSHA's Final Standard for Walking-Working Surfaces
(continued)

NAICS	Industry	Production Worker Mean Hourly Wage		Production Worker Supervisor Mean Hourly Wage	
		Base Rate	With Fringe Markup	Base Rate	With Fringe Markup
3279	Other Nonmetallic Mineral Product Manufacturing	\$16.16	\$22.86	\$26.32	\$37.23
3311	Iron and Steel Mills and Ferroalloy Manufacturing	\$21.33	\$30.17	\$30.13	\$42.62
3312	Steel Product Manufacturing from Purchased Steel	\$17.13	\$24.23	\$26.84	\$37.96
3313	Alumina and Aluminum Production and Processing	\$18.31	\$25.90	\$27.72	\$39.21
3314	Nonferrous Metal (except Aluminum) Production and Processing	\$18.01	\$25.47	\$27.23	\$38.51
3315	Foundries	\$16.25	\$22.98	\$25.90	\$36.63
3321	Forging and Stamping	\$17.27	\$24.43	\$26.81	\$37.92
3322	Cutlery and Handtool Manufacturing	\$16.81	\$23.78	\$28.77	\$40.69
3323	Architectural and Structural Metals Manufacturing	\$16.38	\$23.17	\$26.14	\$36.97
3324	Boiler, Tank, and Shipping Container Manufacturing	\$17.71	\$25.05	\$27.93	\$39.50
3325	Hardware Manufacturing	\$15.73	\$22.25	\$25.85	\$36.56
3326	Spring and Wire Product Manufacturing	\$15.82	\$22.38	\$25.77	\$36.45
3327	Machine Shops; Turned Product; and Screw, Nut, and Bolt Manufacturing	\$18.17	\$25.70	\$28.68	\$40.57
3328	Coating, Engraving, Heat Treating, and Allied Activities	\$15.36	\$21.73	\$25.63	\$36.25
3329	Other Fabricated Metal Product Manufacturing	\$16.96	\$23.99	\$28.02	\$39.63
3331	Agriculture, Construction, and Mining Machinery Manufacturing	\$17.68	\$25.01	\$28.26	\$39.97
3332	Industrial Machinery Manufacturing	\$18.30	\$25.88	\$28.29	\$40.01
3333	Commercial and Service Industry Machinery Manufacturing	\$17.10	\$24.19	\$29.05	\$41.09
3334	Ventilation, Heating, Air-Conditioning, and Commercial Refrigeration Equipment Manufacturing	\$15.63	\$22.11	\$26.25	\$37.13
3335	Metalworking Machinery Manufacturing	\$19.25	\$27.23	\$30.14	\$42.63
3336	Engine, Turbine, and Power Transmission Equipment Manufacturing	\$18.33	\$25.93	\$29.42	\$41.61
3339	Other General Purpose Machinery Manufacturing	\$17.69	\$25.02	\$28.21	\$39.90
3341	Computer and Peripheral Equipment Manufacturing	\$16.42	\$23.22	\$27.12	\$38.36

Table V-5
Wage Rates in Industries Affected by OSHA's Final Standard for Walking-Working Surfaces
(continued)

NAICS	Industry	Production Worker Mean Hourly Wage		Production Worker Supervisor Mean Hourly Wage	
		Base Rate	With Fringe Markup	Base Rate	With Fringe Markup
3342	Communications Equipment Manufacturing	\$16.85	\$23.83	\$30.32	\$42.89
3343	Audio and Video Equipment Manufacturing	\$15.60	\$22.07	\$27.66	\$39.12
3344	Semiconductor and Other Electronic Component Manufacturing	\$15.61	\$22.08	\$27.84	\$39.38
3345	Navigational, Measuring, Electromedical, and Control Instruments Manufacturing	\$17.11	\$24.20	\$29.61	\$41.88
3346	Manufacturing and Reproducing Magnetic and Optical Media	\$16.52	\$23.37	\$26.80	\$37.91
3351	Electric Lighting Equipment Manufacturing	\$15.57	\$22.02	\$25.52	\$36.10
3352	Household Appliance Manufacturing	\$15.91	\$22.50	\$25.15	\$35.57
3353	Electrical Equipment Manufacturing	\$16.30	\$23.06	\$26.99	\$38.18
3359	Other Electrical Equipment and Component Manufacturing	\$15.73	\$22.25	\$26.83	\$37.95
3361	Motor Vehicle Manufacturing	\$24.64	\$34.85	\$32.75	\$46.32
3362	Motor Vehicle Body and Trailer Manufacturing	\$15.94	\$22.55	\$24.74	\$34.99
3363	Motor Vehicle Parts Manufacturing	\$17.17	\$24.29	\$26.35	\$37.27
3364	Aerospace Product and Parts Manufacturing	\$21.12	\$29.87	\$32.33	\$45.73
3365	Railroad Rolling Stock Manufacturing	\$16.97	\$24.00	\$26.53	\$37.52
3366	Ship and Boat Building	\$18.81	\$26.61	\$29.77	\$42.11
3369	Other Transportation Equipment Manufacturing	\$19.00	\$26.87	\$28.05	\$39.67
3371	Household and Institutional Furniture and Kitchen Cabinet Manufacturing	\$14.58	\$20.62	\$23.26	\$32.90
3372	Office Furniture (including Fixtures) Manufacturing	\$15.42	\$21.81	\$25.09	\$35.49
3379	Other Furniture Related Product Manufacturing	\$13.35	\$18.88	\$23.86	\$33.75
3391	Medical Equipment and Supplies Manufacturing	\$16.70	\$23.62	\$28.74	\$40.65
3399	Other Miscellaneous Manufacturing	\$15.01	\$21.23	\$24.86	\$35.16
4231	Motor Vehicle and Motor Vehicle Parts and Supplies Merchant Wholesalers	\$15.91	\$22.50	\$25.17	\$35.60
4232	Furniture and Home Furnishing Merchant Wholesalers	\$14.16	\$20.03	\$24.16	\$34.17

Table V-5
Wage Rates in Industries Affected by OSHA's Final Standard for Walking-Working Surfaces
(continued)

NAICS	Industry	Production Worker Mean Hourly Wage		Production Worker Supervisor Mean Hourly Wage	
		Base Rate	With Fringe Markup	Base Rate	With Fringe Markup
4233	Lumber and Other Construction Materials Merchant Wholesalers	\$15.18	\$21.47	\$24.70	\$34.94
4234	Professional and Commercial Equipment and Supplies Merchant Wholesalers	\$15.73	\$22.25	\$26.73	\$37.81
4235	Metal and Mineral (except Petroleum) Merchant Wholesalers	\$17.06	\$24.13	\$28.26	\$39.97
4236	Electrical and Electronic Goods Merchant Wholesalers	\$15.70	\$22.21	\$27.53	\$38.94
4237	Hardware, and Plumbing and Heating Equipment and Supplies Merchant Wholesalers	\$15.84	\$22.40	\$25.93	\$36.68
4238	Machinery, Equipment, and Supplies Merchant Wholesalers	\$17.05	\$24.12	\$28.87	\$40.83
4239	Miscellaneous Durable Goods Merchant Wholesalers	\$14.94	\$21.13	\$24.84	\$35.13
4241	Paper and Paper Product Merchant Wholesalers	\$15.35	\$21.71	\$25.73	\$36.39
4242	Drugs and Druggists' Sundries Merchant Wholesalers	\$14.50	\$20.51	\$27.00	\$38.19
4243	Apparel, Piece Goods, and Notions Merchant Wholesalers	\$14.30	\$20.23	\$26.48	\$37.45
4244	Grocery and Related Product Wholesalers	\$14.02	\$19.83	\$25.44	\$35.98
4245	Farm Product Raw Material Merchant Wholesalers	\$14.51	\$20.52	\$21.81	\$30.85
4246	Chemical and Allied Products Merchant Wholesalers	\$17.39	\$24.60	\$27.30	\$38.61
4247	Petroleum and Petroleum Products Merchant Wholesalers	\$22.20	\$31.40	\$33.09	\$46.80
4248	Beer, Wine, and Distilled Alcoholic Beverage Merchant Wholesalers	\$16.72	\$23.65	\$26.45	\$37.41
4249	Miscellaneous Nondurable Goods Merchant Wholesalers	\$14.00	\$19.80	\$23.81	\$33.68
4251	Wholesale Electronic Markets and Agents and Brokers	\$15.78	\$22.32	\$27.00	\$38.19
4411	Automobile Dealers	\$21.44	\$30.33	\$34.21	\$48.39
4412	Other Motor Vehicle Dealers	\$15.07	\$21.32	\$28.56	\$40.40
4413	Automotive Parts, Accessories, and Tire Stores	\$14.09	\$19.93	\$24.77	\$35.04
4421	Furniture Stores	\$15.25	\$21.57	\$24.64	\$34.85

Table V-5
Wage Rates in Industries Affected by OSHA's Final Standard for Walking-Working Surfaces
(continued)

NAICS	Industry	Production Worker Mean Hourly Wage		Production Worker Supervisor Mean Hourly Wage	
		Base Rate	With Fringe Markup	Base Rate	With Fringe Markup
4422	Home Furnishings Stores	\$13.50	\$19.09	\$20.89	\$29.55
4431	Electronics and Appliance Stores	\$13.79	\$19.50	\$22.56	\$31.91
4441	Building Material and Supplies Dealers	\$14.82	\$20.96	\$23.97	\$33.90
4442	Lawn and Garden Equipment and Supplies Stores	\$13.96	\$19.75	\$21.32	\$30.16
4451	Grocery Stores	\$13.97	\$19.76	\$21.40	\$30.27
4452	Specialty Food Stores	\$13.12	\$18.56	\$23.39	\$33.08
4453	Beer, Wine, and Liquor Stores	\$15.02	\$21.24	\$21.60	\$30.55
4461	Health and Personal Care Stores	\$12.83	\$18.15	\$23.70	\$33.52
4471	Gasoline Stations	\$16.94	\$23.96	\$22.41	\$31.70
4481	Clothing Stores	\$14.09	\$19.93	\$27.32	\$38.64
4482	Shoe Stores	\$12.02	\$17.00	\$26.92	\$38.08
4483	Jewelry, Luggage, and Leather Goods Stores	\$19.61	\$27.74	\$26.04	\$36.83
4511	Sporting Goods, Hobby, and Musical Instrument Stores	\$11.67	\$16.51	\$20.75	\$29.35
4512	Book, Periodical, and Music Stores	\$16.17	\$22.87	\$20.74	\$29.34
4521	Department Stores	\$11.11	\$15.71	\$24.10	\$34.09
4529	Other General Merchandise Stores	\$11.56	\$16.35	\$21.90	\$30.98
4531	Florists	\$9.80	\$13.86	\$22.22	\$31.43
4532	Office Supplies, Stationery, and Gift Stores	\$12.79	\$18.09	\$18.16	\$25.69
4533	Used Merchandise Stores	\$12.75	\$18.03	\$22.38	\$31.65
4539	Other Miscellaneous Store Retailers	\$13.95	\$19.73	\$23.89	\$33.79
4541	Electronic Shopping and Mail-Order Houses	\$14.37	\$20.33	\$23.91	\$33.82
4542	Vending Machine Operators	\$13.92	\$19.69	\$24.00	\$33.95
4543	Direct Selling Establishments	\$16.03	\$22.67	\$24.35	\$34.44
4811	Scheduled Air Transportation	\$26.36	\$37.28	\$27.45	\$38.83
4812	Nonscheduled Air Transportation	\$22.28	\$31.51	\$27.45	\$38.83
4831	Deep Sea, Coastal, and Great Lakes Water Transportation	\$20.02	\$28.32	\$34.23	\$48.42
4832	Inland Water Transportation	\$19.14	\$27.07	\$27.74	\$39.24
4841	General Freight Trucking	\$17.33	\$24.51	\$27.08	\$38.30

Table V-5
Wage Rates in Industries Affected by OSHA's Final Standard for Walking-Working Surfaces
(continued)

NAICS	Industry	Production Worker Mean Hourly Wage		Production Worker Supervisor Mean Hourly Wage	
		Base Rate	With Fringe Markup	Base Rate	With Fringe Markup
4842	Specialized Freight Trucking	\$17.68	\$25.01	\$28.64	\$40.51
4851	Urban Transit Systems	\$18.50	\$26.17	\$27.45	\$38.83
4852	Interurban and Rural Bus Transportation	\$18.50	\$26.17	\$27.45	\$38.83
4853	Taxi and Limousine Service	\$18.50	\$26.17	\$27.45	\$38.83
4854	School and Employee Bus Transportation	\$18.50	\$26.17	\$27.45	\$38.83
4855	Charter Bus Industry	\$18.50	\$26.17	\$27.45	\$38.83
4859	Other Transit and Ground Passenger Transportation	\$18.50	\$26.17	\$27.45	\$38.83
4861	Pipeline Transportation of Crude Oil	\$27.73	\$39.22	\$29.97	\$42.39
4862	Pipeline Transportation of Natural Gas	\$27.33	\$38.66	\$32.94	\$46.59
4869	Other Pipeline Transportation	\$28.20	\$39.89	\$33.56	\$47.47
4871	Scenic and Sightseeing Transportation, Land	\$19.80	\$28.01	\$27.45	\$38.83
4872	Scenic and Sightseeing Transportation, Water	\$19.80	\$28.01	\$27.45	\$38.83
4879	Scenic and Sightseeing Transportation, Other	\$19.80	\$28.01	\$27.45	\$38.83
4881	Support Activities for Air Transportation	\$19.56	\$27.67	\$28.19	\$39.87
4882	Support Activities for Rail Transportation	\$18.60	\$26.31	\$21.29	\$30.11
4883	Support Activities for Water Transportation	\$18.67	\$26.41	\$26.74	\$37.82
4884	Support Activities for Road Transportation	\$18.56	\$26.25	\$25.80	\$36.49
4885	Freight Transportation Arrangement	\$21.88	\$30.95	\$25.80	\$36.49
4889	Other Support Activities for Transportation	\$14.79	\$20.92	\$22.34	\$31.60
4921	Couriers	\$21.46	\$30.35	\$27.45	\$38.83
4922	Local Messengers and Local Delivery	\$16.69	\$23.61	\$27.45	\$38.83
4931	Warehousing and Storage	\$15.49	\$21.91	\$25.15	\$35.57
5111	Newspaper, Periodical, Book, and Directory Publishers	\$17.27	\$24.43	\$27.58	\$39.01
5112	Software Publishers	\$17.39	\$24.60	\$27.65	\$39.11
5121	Motion Picture and Video Industries	\$18.36	\$25.97	\$28.22	\$39.92
5122	Sound Recording Industries	\$17.31	\$24.48	\$27.86	\$39.41
5151	Radio and Television Broadcasting	\$17.31	\$24.48	\$27.58	\$39.01
5152	Cable and Other Subscription Programming	\$17.31	\$24.48	\$27.58	\$39.01

Table V-5
Wage Rates in Industries Affected by OSHA's Final Standard for Walking-Working Surfaces
(continued)

NAICS	Industry	Production Worker Mean Hourly Wage		Production Worker Supervisor Mean Hourly Wage	
		Base Rate	With Fringe Markup	Base Rate	With Fringe Markup
5161	Internet Publishing and Broadcasting	\$17.31	\$24.48	\$27.58	\$39.01
5171	Wired Telecommunications Carriers	\$23.05	\$32.60	\$27.58	\$39.01
5172	Wireless Telecommunications Carriers (except Satellite)	\$15.49	\$21.91	\$27.58	\$39.01
5173	Telecommunications Resellers	\$21.65	\$30.62	\$27.58	\$39.01
5174	Satellite Telecommunications	\$21.65	\$30.62	\$27.58	\$39.01
5175	Cable and Other Program Distribution	\$21.65	\$30.62	\$27.58	\$39.01
5179	Other Telecommunications	\$22.15	\$31.33	\$27.58	\$39.01
5181	Internet Service Providers and Web Search Portals	\$15.30	\$21.64	\$26.93	\$38.09
5182	Data Processing, Hosting, and Related Services	\$15.30	\$21.64	\$26.93	\$38.09
5191	Other Information Services	\$19.44	\$27.50	\$29.95	\$42.36
5211	Monetary Authorities - Central Bank	\$21.50	\$30.41	\$35.11	\$49.66
5221	Depository Credit Intermediation	\$21.34	\$30.18	\$35.11	\$49.66
5222	Nondepository Credit Intermediation	\$14.96	\$21.16	\$35.11	\$49.66
5223	Activities Related to Credit Intermediation	\$20.00	\$28.29	\$35.11	\$49.66
5231	Securities and Commodity Contracts Intermediation and Brokerage	\$19.34	\$27.36	\$35.11	\$49.66
5232	Securities and Commodity Exchanges	\$21.49	\$30.40	\$35.11	\$49.66
5239	Other Financial Investment Activities	\$21.49	\$30.40	\$35.11	\$49.66
5241	Insurance Carriers	\$19.20	\$27.16	\$34.47	\$48.76
5242	Agencies, Brokerages, and Other Insurance Related Activities	\$13.93	\$19.70	\$34.72	\$49.11
5259	Other Investment Pools and Funds	\$17.91	\$25.33	\$34.72	\$49.11
5311	Lessors of Real Estate	\$23.81	\$33.68	\$32.11	\$45.42
5312	Offices of Real Estate Agents and Brokers	\$17.08	\$24.16	\$31.63	\$44.74
5313	Activities Related to Real Estate	\$21.03	\$29.75	\$31.44	\$44.47
5321	Automotive Equipment Rental and Leasing	\$14.91	\$21.09	\$24.11	\$34.10
5322	Consumer Goods Rental	\$12.53	\$17.72	\$22.92	\$32.42
5323	General Rental Centers	\$14.78	\$20.91	\$24.42	\$34.54

Table V-5
Wage Rates in Industries Affected by OSHA's Final Standard for Walking-Working Surfaces
(continued)

NAICS	Industry	Production Worker Mean Hourly Wage		Production Worker Supervisor Mean Hourly Wage	
		Base Rate	With Fringe Markup	Base Rate	With Fringe Markup
5324	Commercial and Industrial Machinery and Equipment Rental and Leasing	\$18.26	\$25.83	\$26.15	\$36.99
5331	Lessors of Nonfinancial Intangible Assets (except Copyrighted Works)	\$11.86	\$16.78	\$25.37	\$35.88
5411	Legal Services	\$18.60	\$26.31	\$30.54	\$43.20
5412	Accounting, Tax Preparation, Bookkeeping, and Payroll Services	\$18.47	\$26.12	\$30.97	\$43.80
5413	Architectural, Engineering, and Related Services	\$19.32	\$27.33	\$31.52	\$44.58
5414	Specialized Design Services	\$16.74	\$23.68	\$28.99	\$41.00
5415	Computer Systems Design and Related Services	\$18.01	\$25.47	\$30.79	\$43.55
5416	Management, Scientific, and Technical Consulting Services	\$18.88	\$26.70	\$29.25	\$41.37
5417	Scientific Research and Development Services	\$23.34	\$33.01	\$37.14	\$52.53
5418	Advertising and Related Services	\$16.09	\$22.76	\$25.50	\$36.07
5419	Other Professional, Scientific, and Technical Services	\$16.42	\$23.22	\$27.21	\$38.49
5511	Management of Companies and Enterprises	\$19.63	\$27.77	\$28.87	\$40.83
5611	Office Administrative Services	\$17.15	\$24.26	\$28.03	\$39.65
5612	Facilities Support Services	\$17.16	\$24.27	\$30.11	\$42.59
5613	Employment Services	\$12.05	\$17.04	\$24.36	\$34.46
5614	Business Support Services	\$15.91	\$22.50	\$26.03	\$36.82
5615	Travel Arrangement and Reservation Services	\$12.47	\$17.64	\$24.41	\$34.53
5616	Investigation and Security Services	\$16.83	\$23.80	\$22.39	\$31.67
5617	Services to Buildings and Dwellings	\$13.71	\$19.39	\$20.40	\$28.85
5619	Other Support Services	\$13.59	\$19.22	\$23.65	\$33.45
5621	Waste Collection	\$15.41	\$21.80	\$23.78	\$33.64
5622	Waste Treatment and Disposal	\$23.60	\$33.38	\$31.92	\$45.15
5629	Remediation and Other Waste Management Services	\$15.99	\$22.62	\$25.04	\$35.42
6111	Elementary and Secondary Schools	\$20.02	\$28.32	\$28.61	\$40.47
6112	Junior Colleges	\$21.90	\$30.98	\$26.93	\$38.09

Table V-5
Wage Rates in Industries Affected by OSHA's Final Standard for Walking-Working Surfaces
(continued)

NAICS	Industry	Production Worker Mean Hourly Wage		Production Worker Supervisor Mean Hourly Wage	
		Base Rate	With Fringe Markup	Base Rate	With Fringe Markup
6113	Colleges, Universities, and Professional Schools	\$21.66	\$30.64	\$27.10	\$38.33
6114	Business Schools and Computer and Management Training	\$17.52	\$24.78	\$29.40	\$41.58
6115	Technical and Trade Schools	\$19.18	\$27.13	\$34.63	\$48.98
6116	Other Schools and Instruction	\$16.55	\$23.41	\$27.72	\$39.21
6117	Educational Support Services	\$20.63	\$29.18	\$29.01	\$41.03
6211	Offices of Physicians	\$16.81	\$23.78	\$23.35	\$33.03
6212	Offices of Dentists	\$17.78	\$25.15	\$22.72	\$32.14
6213	Offices of Other Health Practitioners	\$14.18	\$20.06	\$22.16	\$31.34
6214	Outpatient Care Centers	\$17.17	\$24.29	\$31.37	\$44.37
6215	Medical and Diagnostic Laboratories	\$16.56	\$23.42	\$26.36	\$37.28
6216	Home Health Care Services	\$12.19	\$17.24	\$24.67	\$34.89
6219	Other Ambulatory Health Care Services	\$16.91	\$23.92	\$26.48	\$37.45
6221	General Medical and Surgical Hospitals	\$16.91	\$23.92	\$27.39	\$38.74
6222	Psychiatric and Substance Abuse Hospitals	\$19.93	\$28.19	\$24.24	\$34.29
6223	Specialty (except Psychiatric and Substance Abuse) Hospitals	\$21.38	\$30.24	\$32.63	\$46.15
6231	Nursing Care Facilities	\$10.14	\$14.34	\$19.04	\$26.93
6232	Residential Mental Retardation, Mental Health and Substance Abuse Facilities	\$10.40	\$14.71	\$18.94	\$26.79
6233	Community Care Facilities for the Elderly	\$10.39	\$14.70	\$20.68	\$29.25
6239	Other Residential Care Facilities	\$12.06	\$17.06	\$19.59	\$27.71
6241	Individual and Family Services	\$16.22	\$22.94	\$20.93	\$29.60
6242	Community Food and Housing, and Emergency and Other Relief Services	\$15.06	\$21.30	\$17.06	\$24.13
6243	Vocational Rehabilitation Services	\$10.53	\$14.89	\$16.96	\$23.99
6244	Child Day Care Services	\$10.92	\$15.45	\$17.06	\$24.13
7111	Performing Arts Companies	\$15.66	\$22.15	\$28.17	\$39.84
7112	Spectator Sports	\$26.38	\$37.31	\$28.17	\$39.84

Table V-5
Wage Rates in Industries Affected by OSHA's Final Standard for Walking-Working Surfaces
(continued)

NAICS	Industry	Production Worker Mean Hourly Wage		Production Worker Supervisor Mean Hourly Wage	
		Base Rate	With Fringe Markup	Base Rate	With Fringe Markup
7113	Promoters of Performing Arts, Sports, and Similar Events	\$13.49	\$19.08	\$28.17	\$39.84
7114	Agents and Managers for Artists, Athletes, Entertainers, and Other Public Figures	\$20.15	\$28.50	\$28.17	\$39.84
7115	Independent Artists, Writers, and Performers	\$15.92	\$22.52	\$28.17	\$39.84
7121	Museums, Historical Sites, and Similar Institutions	\$15.17	\$21.46	\$27.45	\$38.83
7131	Amusement Parks and Arcades	\$16.19	\$22.90	\$33.54	\$47.44
7132	Gambling Industries	\$13.29	\$18.80	\$27.33	\$38.66
7139	Other Amusement and Recreation Industries	\$14.74	\$20.85	\$24.29	\$34.36
7211	Traveler Accommodation	\$11.06	\$15.64	\$19.39	\$27.43
7212	RV (Recreational Vehicle) Parks and Recreational Camps	\$11.05	\$15.63	\$19.39	\$27.43
7213	Rooming and Boarding Houses	\$8.83	\$12.49	\$19.39	\$27.43
7221	Full-Service Restaurants	\$12.09	\$17.10	\$23.27	\$32.91
7222	Limited-Service Eating Places	\$10.73	\$15.18	\$21.62	\$30.58
7223	Special Food Services	\$12.29	\$17.38	\$22.38	\$31.65
7224	Drinking Places (Alcoholic Beverages)	\$14.30	\$20.23	\$22.21	\$31.41
8111	Automotive Repair and Maintenance	\$18.11	\$25.62	\$26.87	\$38.01
8112	Electronic and Precision Equipment Repair and Maintenance	\$16.32	\$23.08	\$27.26	\$38.56
8113	Commercial and Industrial Machinery and Equipment (except Automotive and Electronic) Repair and Maintenance	\$17.81	\$25.19	\$27.46	\$38.84
8114	Personal and Household Goods Repair and Maintenance	\$14.36	\$20.31	\$23.38	\$33.07
8121	Personal Care Services	\$10.30	\$14.57	\$20.51	\$29.01
8122	Death Care Services	\$10.92	\$15.45	\$20.51	\$29.01
8123	Dry-cleaning and Laundry Services	\$10.71	\$15.15	\$20.22	\$28.60
8129	Other Personal Services	\$14.69	\$20.78	\$24.69	\$34.92

Table V-5
Wage Rates in Industries Affected by OSHA's Final Standard for Walking-Working Surfaces
(continued)

NAICS	Industry	Production Worker Mean Hourly Wage		Production Worker Supervisor Mean Hourly Wage	
		Base Rate	With Fringe Markup	Base Rate	With Fringe Markup
8131	Religious Organizations	\$15.18	\$21.47	\$21.13	\$29.89
8132	Grantmaking and Giving Services	\$15.34	\$21.70	\$21.13	\$29.89
8133	Social Advocacy Organizations	\$12.19	\$17.24	\$15.79	\$22.33
8134	Civic and Social Organizations	\$14.33	\$20.27	\$21.13	\$29.89
8139	Business, Professional, Labor, Political, and Similar Organizations	\$17.15	\$24.26	\$28.06	\$39.69

Source: U.S. Department of Labor, OSHA, Directorate of Standards and Guidance, Office of Regulatory Analysis, based on BLS, Occupational Employment Statistics Survey, 2010, and BLS, Employer Costs for Employee Compensation – June 2011.

6. Other Factors of Production Profiled for This FEA

Factors of production relevant to the final cost analysis included not only establishments, employers, and employees in general industry, but also the following walking and working surfaces:

- Manhole Steps and Rungs
- Stepbolts on Utility and Communication Poles and Towers
- Commercial and Residential Buildings (Window Cleaning) and
- Fixed Ladders

Details on the sources, count, dimensions, and other factors are provided in the cost discussions below in Section E.

D. Benefits, Net Benefits, Cost Effectiveness, and Sensitivity Analysis

1. Introduction

This section reviews the populations in general industry that are at risk of occupational injury or death due to hazards associated with slips, trips, or falls to lower levels, and assesses the potential benefits associated with the changes to subparts D and I resulting from the final rule. OSHA believes that compliance with the final rule will yield substantial benefits in terms of lives saved, injuries avoided, and reduced accident-related costs. Applying updated accident data and incorporating information from the record, OSHA revised its preliminary estimate of (1)

the baseline level of risk and (2) prevented deaths and injuries due to the final rule.

As described in Section C of this FEA (Industry Profile) above, the employees affected by the final standard work largely in construction, installation, maintenance, and repair. According to the Bureau of Labor Statistics' 2007 Occupational Employment Statistics survey, there are approximately 112.3 million employees in industries within the scope of this final rule: 5.2 million employees engaged in construction, installation, maintenance, and repair operations in general industry that OSHA judges will need ladder training because these occupations are the most likely to use ladders in their work;¹¹⁰

¹¹⁰Ladder use is not limited to these occupations, and there are many persons in these occupations that do not use ladders. OSHA examined ladder fatalities recorded by BLS from 2011 through 2014 and found that 68 percent of ladder fatalities were in the occupations OSHA included as needing ladder training. However, of the 5.2 million included, many such as computer and electronics repair technicians and auto mechanics have low rates of ladder fatalities indicating that ladders are likely rarely used in these occupations. Over two million of those included as always needing ladder training are thus unlikely to need ladder training. This potential overestimate of ladder training costs is probably countered by the number of other workers who potentially use ladders but are excluded from the 5.2 million, such as 950,000 grounds maintenance workers who provide over 5 percent of ladder fatalities. The remaining 27 percent of ladder fatalities are very widely dispersed; ladder fatalities are found in every major occupational group.

and 2.1 million employees in general industry using personal fall protection equipment. The rule also affects workers in a variety of specific kinds of work who may enter manholes using step bolts, use scaffolds or rope descent systems, etc. The inclusion of construction occupations assumes that employees in construction occupations, but employed by general industry rather than construction employers, routinely engage in what OSHA labels as maintenance (*i.e.*, a general industry activity) rather than construction activities.

This section first examines the available data on the number of baseline injuries and fatalities among affected employees; then assesses the extent to which the standard can prevent those injuries and fatalities; and finally estimates some of the economic benefits associated with the prevented injuries and fatalities. This final standard would produce benefits to the extent that compliance prevents injuries and fatalities that would otherwise occur.

2. Profile of Fall Accidents

a. Fall Fatalities

OSHA examined fall fatalities using two databases. As a baseline for determining the average number of fall fatalities per year, OSHA examined data from the BLS *Census of Fatal Occupational Injuries* (CFOI) for 2006 through 2012. To provide a more detailed breakdown of the kinds of falls

included in this total, OSHA in the PEA examined CFOI data for a longer period: 1992 to 2002. For this FEA, OSHA has updated the detailed breakdown using data from 2006–2010 and applies this updated breakdown of the kinds of affected falls to the 2006–2012 fatality data.¹¹¹

Distinguished from the larger category of all falls—*i.e.*, a set of accidents that includes falls on the same level, falls to a lower level, and jumps to a lower level—the narrower category of falls to a lower level consists of the types of

falls directly addressed by most of the changes to OSHA's requirements by this final standard. As shown in Table V–6, the CFOI reported 283 and 279 fatal falls to lower levels for 2006 and 2007, respectively, in industries covered by the final standard; for the five most recent years for which the data were available, fatal falls to a lower level declined to an average of 252 fatalities. For purposes of estimating the overall rate of fall fatalities for this benefits analysis, OSHA took the average of these seven years—*i.e.*, 261 fall fatalities to a lower level per year. Over the seven-year period, the Professional, Scientific, and Technical Services industry and the Administrative and Support Services industry (NAICS codes

541 and 561, respectively) accounted for 27 percent of the fatal falls, while the Manufacturing (NAICS codes 31–33) and Transportation (NAICS code 48) industries accounted for 9.6 and 7.1 percent of the fall fatalities, respectively. Among all three-digit NAICS codes affected by the standard, BLS reported the highest number of fatal falls in NAICS code 561, Administrative and Support Services. Although not shown in the table, a large majority of the fatalities for Administrative and Support Services—86 percent for the seven-year period 2006–2012—occurred in the industry concerned with services to buildings and dwellings (NAICS code 5617).

¹¹¹ Beginning in 2011, BLS revised the system for reporting types of fatal fall events. The detailed fatality events shown below in Tables V–11 were no longer available after 2010.

Table V-6
Fatalities from Falls to a Lower Level - General Industry, 2006-2012

NAICS	NAICS Description	Number of Fatalities						
		2006	2007	2008	2009	2010	2011[a]	2012
113	Forestry and Logging	3	4	0	0	0	0	3
114	Fishing, Hunting and Trapping	0	0	0	0	0	2	2
115	Support Activities for Agriculture and Forestry	0	0	0	0	0	3	0
211	Oil and Gas Extraction	0	0	0	0	0	0	4
213111	Oil and Gas Well Drilling	5	4	4	0	6	4	8
221	Utilities	6	4	0	4	0	6	0
311	Food Manufacturing	5	4	6	5	10	4	6
312	Beverage and Tobacco Product Manufacturing	0	0	0	0	0	0	0
313	Textile Mills	0	0	0	0	0	0	0
314	Textile Product Mills	0	0	0	0	0	0	0
315	Apparel Manufacturing	0	0	0	0	0	0	0
316	Leather and Allied Product Manufacturing	0	0	0	0	0	0	0
321	Wood Product Manufacturing	7	0	0	0	4	0	0
322	Paper Manufacturing	0	0	0	0	0	3	0
323	Printing and Related Support Activities	0	0	0	0	0	0	0
324	Petroleum and Coal Products Manufacturing	0	0	0	0	0	0	0
325	Chemical Manufacturing	3	3	0	3	0	1	0
326	Plastics and Rubber Products Manufacturing	3	0	0	0	0	1	0
327	Nonmetallic Mineral Product Manufacturing	3	0	3	0	0	3	0
331	Primary Metal Manufacturing	0	0	9	0	0	1	4
332	Fabricated Metal Product Manufacturing	10	7	4	3	6	6	0

Table V-6
Fatalities from Falls to a Lower Level - General Industry, 2006-2012 (continued)

NAICS	NAICS DESCRIPTION	Number of Fatalities						
		2006	2007	2008	2009	2010	2011[a]	2012
333	Machinery Manufacturing	0	0	0	0	0	3	0
334	Computer and Electronic Product Manufacturing	0	0	0	0	0	2	0
335	Electrical Equipment, Appliance, and Component Manufacturing	0	0	0	0	0	0	0
336	Transportation Equipment Manufacturing	7	4	6	4	4	3	6
337	Furniture and Related Product Manufacturing	0	0	0	0	0	0	0
339	Miscellaneous Manufacturing	0	4	0	0	0	4	2
423	Merchant Wholesalers, Durable Goods	4	7	5	10	0	8	7
424	Merchant Wholesalers, Nondurable Goods	12	6	5	5	8	3	15
425	Wholesale Electronic Markets and Agents and Brokers	0	0	0	0	0	0	0
441	Motor Vehicle and Parts Dealers	4	0	4	0	3	0	0
442	Furniture and Home Furnishings Stores	0	0	0	0	0	0	0
443	Electronics and Appliance Stores	0	0	0	0	0	0	0
444	Building Material and Garden Equipment and Supplies Dealers	6	4	0	4	9	0	4
445	Food and Beverage Stores	5	0	0	0	0	1	3
446	Health and Personal Care Stores	0	0	0	0	0	0	0
447	Gasoline Stations	0	0	0	0	0	1	0
448	Clothing and Clothing Accessories Stores	0	0	0	0	0	0	0
451	Sporting Goods, Hobby, Book, and Music Stores	0	0	0	0	0	0	0
452	General Merchandise Stores	0	0	3	4	0	0	3
453	Miscellaneous Store Retailers	0	0	0	4	0	0	3
454	Nonstore Retailers	0	0	3	0	0	1	0

Table V-6
Fatalities from Falls to a Lower Level - General Industry, 2006-2012 (continued)

NAICS	NAICS DESCRIPTION	Number of Fatalities						
		2006	2007	2008	2009	2010	2011[a]	2012
481	Air Transportation	0	0	0	0	0	1	0
482	Railroads	0	0	0	0	0	0	0
483	Water Transportation	0	0	0	0	0	0	0
484	Truck Transportation	11	18	24	12	20	9	14
485	Transit and Ground Passenger Transportation	0	0	0	0	0	0	0
486	Pipeline Transportation	0	0	0	0	0	0	0
487	Scenic and Sightseeing Transportation	0	0	0	0	0	0	0
488	Support Activities for Transportation	0	4	4	3	4	0	5
492	Couriers and Messengers	0	0	0	0	0	0	0
493	Warehousing and Storage	4	5	0	3	0	6	3
511	Publishing Industries (except Internet)	0	0	0	0	0	0	0
512	Motion Picture and Sound Recording Industries	0	0	0	0	0	4	0
515	Broadcasting (except Internet)	0	0	0	0	0	3	0
516	Internet Publishing and Broadcasting	0	0	0	0	0	0	0
517	Telecommunications	6	3	0	4	0	3	0
518	Internet Service Providers, Web Search Portals, and Data Processing Services	0	0	0	0	0	0	0
519	Other Information Services	0	0	0	0	0	0	0
521	Monetary Authorities - Central Bank	0	0	0	0	0	0	0
522	Credit Intermediation and Related Activities	0	0	0	0	3	0	0
523	Securities, Commodity Contracts, and Other Financial Investments and Related Activities	0	0	0	0	0	0	0

**Table V-6
Fatalities from Falls to a Lower Level - General Industry, 2006-2012 (continued)**

NAICS	NAICS DESCRIPTION	Number of Fatalities						
		2006	2007	2008	2009	2010	2011[a]	2012
524	Insurance Carriers and Related Activities	3	0	0	0	0	0	0
525	Funds, Trusts, and Other Financial Vehicles	0	0	0	0	0	0	0
531	Real Estate	10	9	14	8	12	4	12
532	Rental and Leasing Services	0	0	0	0	0	0	0
533	Lessors of Nonfinancial Intangible Assets (except Copyrighted Works)	0	0	0	0	0	0	0
541	Professional, Scientific, and Technical Services	7	10	9	5	5	4	7
551	Management of Companies and Enterprises	0	0	0	0	0	0	0
561	Administrative and Support Services	66	80	45	68	47	84	60
562	Waste Management and Remediation Services	5	0	0	3	0	4	6
611	Educational Services	4	0	0	0	3	0	0
621	Ambulatory Health Care Services	0	0	0	6	3	0	0
622	Hospitals	0	0	0	0	0	0	0
623	Nursing and Residential Care Facilities	4	0	0	0	4	0	3
624	Social Assistance	0	3	0	0	4	0	3
711	Performing Arts, Spectator Sports, and Related Industries	6	3	0	4	3	3	0
712	Museums, Historical Sites, and Similar Institutions	0	0	0	0	0	0	0
713	Amusement, Gambling, and Recreation Industries	0	7	3	0	4	5	5
721	Accommodation	8	5	0	0	0	5	0
722	Food Services and Drinking Places	4	7	4	5	5	0	0
811	Repair and Maintenance	6	4	7	6	7	7	4
812	Personal and Laundry Services	0	0	0	0	0	0	0

**Table V-6
Fatalities from Falls to a Lower Level - General Industry, 2006-2012 (continued)**

NAICS	NAICS DESCRIPTION	Number of Fatalities						
		2006	2007	2008	2009	2010	2011[a]	2012
813	Religious, Grantmaking, Civic, Professional, and Similar Organizations	11	7	7	0	9	3	4
	Industries not specified[b]	45	63	65	64	60	73	74
Total		283	279	234	237	243	278	270

[a] Reference year 2011 is the first year in which the IIF program used the Occupational Injury and Illness Classification System (OIICS), version 2.01, when classifying Event or Exposure, Primary Source, Secondary Source, Nature, and Part of Body. Due to substantial differences between OIICS 2.01 and the original OIICS structure, which was used from 1992 to 2010, data for these case characteristics from 2011 forward should not be compared to prior years. The data shown in this table are presented for convenience of illustration; a comparison across the two time spans mentioned above is not intended.

[b] Includes falls from ship, boat, not elsewhere classified.

Source: U.S. Department of Labor, OSHA, Directorate of Standards and Guidance, Office of Regulatory Analysis, based on BLS, Census of Fatal Occupational Injuries, 2006-2012.

To assess the benefits of this rule, it is necessary to determine not only the

total annual number of fall fatalities, but also the number of various types of fall fatalities. Quantifying the various types of fatal falls is necessary because the

final standard will prevent fall fatalities to different degrees for different types of falls. Table V-7 shows, for the 5-year period 2006 to 2010, the breakdown of fall fatalities by type of fall based on CFOI data. As shown, falls to a lower level (distinguished from falls on the same level) accounted for about 77

percent of total fall fatalities.¹¹² On a sector-by-sector basis, falls to a lower level as a percentage of all fatal falls ranged from 50 percent for the

¹¹²The average for 2006–2010 shown in Table V-7 (333 fatalities) differs from the baseline estimate applied in OSHA's benefits analysis (345 fatalities; see Table V-11) due to the addition of two years (2011 and 2012) in OSHA's estimate of the baseline average. See Ex. [OSHA Excel Workbook], tab Prevented Fatalities '06-'12.

Educational Services (1.4 of 2.8, unrounded) and Health Care and Social Assistance sectors (6.4 of 12.8, unrounded) to 91 percent for the Administration and Support and Waste Management and Remediation Services sector (64 of 74.6, unrounded). As Table V-7 also shows, fatal falls from ladders averaged 56 per year over the 5-year period, while fatal falls from scaffolds averaged 13 per year.

Table V-7
Fatal Falls by Type of Fall and Industry Sector, 2006-2010

NAICS - Industry Sector	All Falls	Falls to a Lower Level			
		Total[a]	From a Ladder	From a Roof	From a Scaffold
Total Fatal Falls, 2006-2010					
11 - Agriculture, forestry, fishing, and hunting	151	126	22	10	N/A
22 - Utilities	17	14	N/A	N/A	N/A
31-33 - Manufacturing	246	192	45	22	17
42 - Wholesale trade	97	70	13	N/A	N/A
44-45 - Retail trade	157	94	38	4	N/A
48-79 - Transportation and warehousing	174	131	4	N/A	N/A
51 - Information	40	26	4	N/A	N/A
52 - Finance and insurance	15	9	N/A	N/A	N/A
53 - Real estate and rental and leasing	66	57	16	8	N/A
54 - Professional, scientific, and technical services	45	36	5	3	N/A
56 - Administration and support and waste management and remediation services	353	320	59	34	10
61 - Educational services	14	7	N/A	N/A	N/A
62 - Health care and social assistance	64	32	N/A	N/A	N/A
71 - Arts, entertainment, and recreation	49	37	N/A	N/A	N/A
72 - Accommodation and food services	75	40	9	N/A	N/A
81 - Other services	92	72	25	3	3
Total [b]	1,664	1,276	280	125	66
Average Fatal Falls per Year, 2006-2010					
11 - Agriculture, forestry, fishing, and hunting	30	25	4	2	N/A
22 - Utilities	3	3	N/A	N/A	N/A

31-33 - Manufacturing	49	38	9	4	3
42 - Wholesale trade	19	14	3	N/A	N/A
44-45 - Retail trade	31	19	8	1	N/A
48-79 - Transportation and warehousing	35	26	1	N/A	N/A
51 - Information	8	5	1	N/A	N/A

NAICS - Industry Sector	All Falls	Falls to a Lower Level			
		Total[a]	From a Ladder	From a Roof	From a Scaffold
52 - Finance and insurance	3	2	N/A	N/A	N/A
53 - Real estate and rental and leasing	13	11	3	2	N/A
54 - Professional, scientific, and technical services	9	7	1	1	N/A
56 - Administration and support and waste management and remediation services	71	64	12	7	2
61 - Educational services	3	1	N/A	N/A	N/A
62 - Health care and social assistance	13	6	N/A	N/A	N/A
71 - Arts, entertainment, and recreation	10	7	N/A	N/A	N/A
72 - Accommodation and food services	15	8	2	N/A	N/A
81 - Other services	18	14	5	1	1
Total [b]	333	255	56	25	13

Notes: Titles for industry sectors use BLS' classifications and correspond to 2-digit NAICS. Data in the table are rounded.

N/A – Indicates no data reported or data that did not meet BLS publication criteria.

[a] Totals for falls to a lower level include other types of falls to lower levels not shown separately.

Therefore, the number of falls from a ladder, roof, and scaffold may not sum to the total number of falls to a lower level.

[b] Totals include falls in industries not shown separately in the table. Therefore totals may not equal the sum of the data for the industry sectors shown in the table.

Source: U.S. Dept. of Labor, OSHA, Directorate of Standards and Guidance, Office of Regulatory Analysis-Safety, based on BLS, Census of Fatal Occupational Injuries, 2006–2010.

b. Fall Injuries

Table V–8, based on BLS’s *Survey of Occupational Injuries and Illnesses*, shows the average number of lost-workday injuries due to falls in general industry, by type of fall, for 2006–2012. The number of falls to lower level (48,379) and the number of falls on same level (137,079) were calculated as the average of injury data reported by BLS for 2006–2012. OSHA allocated the average number of falls to a lower level (48,379) among the different fall to a lower level categories based on the average distribution of falls to a lower level for 2006–2010.¹¹³ The estimate of other falls is derived as the difference

¹¹³ Data on injuries associated with types of fall to lower level were reported only up until 2010.

between total falls and the sum of falls to lower level and falls on same level. As Table V–8 shows, unlike fall fatalities, falls to a lower level represent a relatively small share of injurious, non-fatal, falls. This table forms the basis for OSHA’s estimate of the number of lost-workday injuries prevented by the final standard.

Table V–9, also based on BLS’s *2010 Survey of Occupational Injuries and Illnesses*, provides additional details about the lost-workday injury rates for the two major categories of falls: Falls to a lower level and falls to the same level. Excluding industry groups for which the data are incomplete, the combined fall injury rate ranges from a low of 3.2 cases per 10,000 workers in NAICS 518 (Internet Service Providers, Web Search

Portals, and Data Processing Services) to a high of 72.0 per 10,000 employees in NAICS 481 (Air Transportation). Of the 81 affected industries with reported fall injury data, 17 had fall injury rates in excess of 30 cases per 10,000 employees, while 28 had fall injury rates between 20 and 30 cases per 10,000 employees.

Table V–10, also based on BLS’s *2010 Survey of Occupational Injuries and Illnesses*, shows lost-workday fall-related injury rates by specific type of fall, disaggregated by the major industry sectors covered by the final standard. The majority of accidents in the fall-to-same-level category are falls to a floor, walkway, or other surface.

Table V-8**Estimated Annual Number of Lost-Workday Falls in Workplaces Affected by the Final Standard**

Type of Fall		Annual Average Number of Falls, 2006-2012
Fall to lower level		48,379
	Fall down stairs or steps	14,726
	Fall from floor, dock, or ground level	3,987
	Fall from ladder	10,805
	Fall from piled or stacked material	370
	Fall from roof	429
	Fall from scaffold, staging	597
	Fall from building girders or other structural steel	134
	Fall from nonmoving vehicle	9,188
	Fall to lower level, n.e.c.	7,230
	Fall to lower level, unspecified	921
Fall on same level		137,079
Other falls (incl. ship, boat)		16,609
Total		202,066

Source: U.S. Department of Labor, OSHA, Directorate of Standards and Guidance, Office of Regulatory Analysis, based on BLS, Survey of Occupational Injuries and Illnesses, 2006-2012.

**Table V-9
Injuries From Falls - General Industry, 2010**

NAICS	NAICS Description	Lost-Workday Cases per 10,000 Workers			Industry Rank	Estimated Number of Falls
		Falls to Lower Level	Falls on Same Level	All Falls		
113	Forestry and Logging	11	17.3	28.3	18	140
114	Fishing, Hunting and Trapping	0	0	0	81	0
115	Support Activities for Agriculture and Forestry	11.2	20.7	31.9	13	790
211	Oil and Gas Extraction	2	7.4	9.4	70	140
213111	Oil and Gas Well Drilling	4.5	10.2	14.7	58	100
221	Utilities	6.5	14.1	20.6	40	1,130
311	Food Manufacturing	7.1	18.3	25.4	26	3,660
312	Beverage and Tobacco Product Manufacturing	5.9	20.3	26.2	23	470
313	Textile Mills	3.2	10.6	13.8	60	160
314	Textile Product Mills	0	10	10	68	110
315	Apparel Manufacturing	1.9	9.9	11.8	67	170
316	Leather and Allied Product Manufacturing	0	15.2	15.2	55	40
321	Wood Product Manufacturing	7.8	14.5	22.3	33	740
322	Paper Manufacturing	4.9	13.9	18.8	45	760
323	Printing and Related Support Activities	2.1	16.5	18.6	46	870
324	Petroleum and Coal Products Manufacturing	4.8	4.5	9.3	71	110
325	Chemical Manufacturing	6.2	8.6	14.8	57	1,180
326	Plastics and Rubber Products Manufacturing	4.4	15.2	19.6	42	1,210
327	Nonmetallic Mineral Product Manufacturing	9.9	11.2	21.1	38	770
331	Primary Metal Manufacturing	5.3	12.3	17.6	52	640
332	Fabricated Metal Product Manufacturing	5.4	8.5	13.9	59	1,750
333	Machinery Manufacturing	2.7	11.1	13.8	61	1,360
334	Computer and Electronic Product Manufacturing	2.1	5	7.1	77	770

**Table V-9
Injuries From Falls - General Industry, 2010 (continued)**

NAICS	NAICS Description	Lost-Workday Cases per 10,000 Workers			Industry Rank	Estimated Number of Falls
		Falls to Lower Level	Falls on Same Level	All Falls		
335	Electrical Equipment, Appliance, and Component Manufacturing	1.5	5.9	7.4	76	260
336	Transportation Equipment Manufacturing	6.3	11.9	18.2	47	2,380
337	Furniture and Related Product Manufacturing	6.2	11.6	17.8	50	620
339	Miscellaneous Manufacturing	5.8	9.3	15.1	56	830
423	Merchant Wholesalers, Durable Goods	5.2	11.1	16.3	54	4,310
424	Merchant Wholesalers, Nondurable Goods	9	18.2	27.2	22	5,040
425	Wholesale Electronic Markets and Agents and Brokers	1.6	10.8	12.4	65	970
441	Motor Vehicle and Parts Dealers	5.8	13.6	19.4	43	2,990
442	Furniture and Home Furnishings Stores	15.1	19.6	34.7	9	1,210
443	Electronics and Appliance Stores	3.2	5.3	8.5	74	350
444	Building Material and Garden Equipment and Supplies Dealers	9.9	12.7	22.6	30	2,320
445	Food and Beverage Stores	3.9	22.2	26.1	24	5,490
446	Health and Personal Care Stores	4.4	13.3	17.7	51	1,320
447	Gasoline Stations	3.8	18.3	22.1	35	1,420
448	Clothing and Clothing Accessories Stores	4.7	8.9	13.6	63	1,110
451	Sporting Goods, Hobby, Book, and Music Stores	4.2	8	12.2	66	470
452	General Merchandise Stores	5.1	22.6	27.7	21	6,060
453	Miscellaneous Store Retailers	10.3	12.4	22.7	29	1,240
454	Nonstore Retailers	14.3	22.8	37.1	8	1,340
481	Air Transportation	20.8	51.2	72	1	2,630
482	Railroads	19.6	2.2	21.8	36	580
483	Water Transportation	9.3	11.5	20.8	39	160
484	Truck Transportation	27.6	33.1	60.7	2	7,960
485	Transit and Ground Passenger Transportation	9.9	38.8	48.7	4	1,480
486	Pipeline Transportation	9.7	0	9.7	69	40
487	Scenic and Sightseeing Transportation	9.3	19.2	28.5	17	50
488	Support Activities for Transportation	8.7	16	24.7	27	1,270
492	Couriers and Messengers	12.3	36	48.3	5	1,840
493	Warehousing and Storage	6.7	21.2	27.9	20	1,630
511	Publishing Industries (except Internet)	4.2	8.7	12.9	64	920
512	Motion Picture and Sound Recording Industries	2.3	19.5	21.8	37	580

**Table V-9
Injuries From Falls - General Industry, 2010 (continued)**

NAICS	NAICS Description	Lost-Workday Cases per 10,000 Workers			Industry Rank	Estimated Number of Falls
		Falls to Lower Level	Falls on Same Level	All Falls		
515	Broadcasting (except Internet)	11.3	18.3	29.6	15	810
516	Internet Publishing and Broadcasting	N/R	N/R	N/R		N/R
517	Telecommunications	10.1	18.9	29	16	2,610
518[a]	Internet Service Providers, Web Search Portals, and Data Processing Services	NR	NR	NR		NR
519[b]	Other Information Services	0	4.6	4.6	80	60
521	Monetary Authorities - Central Bank	NR	NR	NR		NR
522	Credit Intermediation and Related Activities	1.5	6.5	8	75	1,900
523	Securities, Commodity Contracts, and Other Financial Investments and Related Activities	6.6	2.4	9	73	680
524	Insurance Carriers and Related Activities	2.8	6.5	9.3	72	1,800
525	Funds, Trusts, and Other Financial Vehicles	11.3	6.9	18.2	48	140
531	Real Estate	11.8	12.3	24.1	28	2,880
532	Rental and Leasing Services	6.5	12.7	19.2	44	890
533	Lessors of Nonfinancial Intangible Assets (except Copyrighted Works)	0	6.4	6.4	79	20
541	Professional, Scientific, and Technical Services	2.3	4.8	7.1	78	4,850
551 [c]	Management of Companies and Enterprises	4.1	9.7	13.8	62	2,420
561	Administrative and Support Services	8.3	17.4	25.7	25	10,660
562	Waste Management and Remediation Services	15.7	14.8	30.5	14	1,100
611	Educational Services	4.5	15.3	19.8	41	3,360
621	Ambulatory Health Care Services	3.7	12.8	16.5	53	7,710
622	Hospitals	4.8	28	32.8	12	12,030
623	Nursing and Residential Care Facilities	4.8	50.5	55.3	3	13,510
624	Social Assistance	11.4	26.4	37.8	7	6,830
711	Performing Arts, Spectator Sports, and Related Industries	9.2	13.2	22.4	32	510
712	Museums, Historical Sites, and Similar Institutions	11.7	22.4	34.1	10	290
713	Amusement, Gambling, and Recreation Industries	11.7	21.7	33.4	11	2,870
721	Accommodation	9.5	29.4	38.9	6	5,170
722	Food Services and Drinking	2.7	19.5	22.2	34	12,910

Table V-9
Injuries From Falls - General Industry, 2010 (continued)

NAICS	NAICS Description	Lost-Workday Cases per 10,000 Workers			Industry Rank	Estimated Number of Falls
		Falls to Lower Level	Falls on Same Level	All Falls		
	Places					
811	Repair and Maintenance	15.9	12.3	28.2	19	2,980
812	Personal and Laundry Services	2.8	15.3	18.1	49	1,690
813	Religious, Grantmaking, Civic, Professional, and Similar Organizations	6.3	16.2	22.5	31	2,050

[a] Discontinued in 2009. NR: Not reported for 2010.

[b] Scope changed in 2009.

[c] Data for code SP2MCE—Management of Companies and Enterprises.

Source: U.S. Department of Labor, OSHA, Directorate of Standards and Guidance, Office of Regulatory Analysis-Safety, based on BLS, Survey of Occupational Injuries and Illnesses: Case and Demographic Information, 2010.

Table V-10
Fall Incidents by Type of Fall and Sector, 2010
(Lost-Workday Cases per 10,000 Workers)

Event Code	Type of Fall	Private Industry	Manufacturing	Trade, Transportation, and Utilities	Information	Financial Activities	Professional and Building Services	Education and Health Services	Leisure and Hospitality	Other Services
10	Fall, unspecified	0.7	0.5	1.2	0.3	0.2	0.4	0.9	0.6	0.5
11	Fall to lower level	6.9	5	8.1	6.4	4.7	4.8	5.2	5	8.7
110	Fall to lower level, Unspecified	0.1	0.1	0.2	[b]	[a]	0.1	0.2	0.1	0.1
111	Fall down stairs or Steps	1.9	1.1	1.7	2.1	1.6	1.7	2.8	2.6	3
112[c]	Fall from floor, dock, or Ground	0.8	0.9	0.8	0.6	1	0.6	0.6	0.5	0.4
1120	Fall from floor, dock, or ground level, unspecified	0.1	0.2	0.3	[b]	0.1	0.1	[a]	[a]	[b]
1121	Fall through existing floor opening	0.4	0.5	0.2	0.1	0.7	0.4	0.3	0.3	0.2
1122	Fall through floor Surface	0.1	[b]	0.1	0.1	0.1	[a]	0.1	[a]	1
1123	Fall from loading Dock	0.1	[a]	0.1	[b]	[b]	[a]	[a]	[a]	[b]
1124	Fall from ground level to lower level	0.1	0.1	0.1	0.2	0.1	[a]	0.1	[a]	[b]
1129	Fall from floor, dock, or ground level, n.e.c.	0.1	[a]	0.1	0.1	[b]	[b]	0.1	0.1	[b]

Table V-10
Fall Incidents by Type of Fall and Sector, 2010 (continued)
(Lost-Workday Cases per 10,000 Workers)

Event Code	Type of Fall	Private Industry	Manufacturing	Trade, Transportation, and Utilities	Information	Financial Activities	Professional and Building Services	Education and Health Services	Leisure and Hospitality	Other Services
113	Fall from ladder	1.7	1.3	2	1.8	1.3	0.9	0.4	0.7	2
114	Fall from piled or stacked material	[a]	0.1	0.1	[b]	[b]	[b]	[b]	[b]	[b]
115	Fall from roof	0.2	0.1	[b]	[b]	0.1	[a]	[b]	0.1	0.3
1150	Fall from roof, unspecified	[a]	[b]	[b]	[b]	[a]	[b]	[b]	[b]	0.3
1151	Fall through existing roof opening	[a]	[b]	[b]	[b]	[b]	[b]	[b]	[b]	[b]
1152	Fall through roof surface	[a]	[b]	[a]	[b]	[b]	[b]	[b]	[b]	[b]
1153	Fall through skylight	[a]	[b]	[b]	[b]	[b]	[b]	[b]	[b]	[b]
1154	Fall from roof edge	0.1	0.1	[b]	[b]	[b]	[a]	[b]	[b]	[b]
1159	Fall from roof, n.e.c.	[a]	[b]	[b]	[b]	[b]	[b]	[b]	[b]	[b]
116	Fall from scaffolding, staging	0.2	0.2	[a]	0.1	[b]	0.1	0.1	[b]	0.2
117	Fall from building girders or other structural steel	[a]	[a]	[a]	[b]	[b]	[b]	[b]	[b]	[b]
118	Fall from nonmoving vehicle	1.1	0.7	2.3	1.2	0.3	0.6	0.2	0.2	2.2
119	Fall to lower level, n.e.c.	0.8	0.6	0.9	0.5	0.4	0.9	1	0.8	0.5
12	Jump to lower level	0.3	0.2	0.4	0.5	0.1	0.2	0.1	0.2	0.7
120	Jump to lower level, Unspecified	[a]	0.1	[a]	[b]	[b]	[a]	[b]	[b]	[b]

**Table V-10
Fall Incidents by Type of Fall and Sector, 2010 (continued)
(Lost-Workday Cases per 10,000 Workers)**

Event Code	Type of Fall	Private Industry	Manufacturing	Trade, Transportation, and Utilities	Information	Financial Activities	Professional and Building Services	Education and Health Services	Leisure and Hospitality	Other Services
121	Jump from scaffold, platform, loading dock	[a]	[a]	[a]	[b]	[b]	[b]	[a]	[b]	[b]
122	Jump from structure, structural steel, n.e.c.	[a]	[b]	[a]	0.2	[b]	[b]	[b]	[a]	0.1
123	Jump from nonmoving vehicle	0.1	0.1	0.2	[b]	0.1	0.1	[a]	[a]	0.4
129	Jump to lower level, n.e.c.	0.1	0.1	0.1	0.3	[b]	0.1	[a]	0.1	0.2
13	Fall on same level	16.1	11.5	18.1	14.6	7.5	9.7	25.1	21.2	14.5
130	Fall on same level, unspecified	0.1	[a]	0.1	[b]	[b]	0.1	0.1	0.1	[b]
131	Fall to floor, walkway, or other surface	14.2	15.1	15.3	13.5	6.8	8.6	23	19.2	13.5
132	Fall onto or against objects	1.8	1.7	2.6	1.1	0.6	1.1	1.9	1.9	0.9
139	Fall on same level, n.e.c.	0.1	0.1	0.1	[b]	[b]	[b]	0.1	[a]	[b]
19	Fall, n.e.c.	0.1	0.1	0.2	[b]	[b]	[a]	0.1	0.1	[b]
	All falls	24.1	17.3	27.9	21.8	12.4	15.2	31.4	27	24.5

[a]Less than 0.1 cases per 10,000 workers.

[b]Data not available.

[c]Here and elsewhere in this table, data may not sum to totals due to rounding.

Source: U.S. Department of Labor, OSHA, Directorate of Standards and Guidance, Office of Regulatory Analysis-Safety, based on Bureau of Labor Statistics, Survey of Occupational Injuries and Illnesses: Case and Demographic Information, 2010.

employees for the Financial Activities sector to 8.1 per 10,000 employees for the Trade, Transportation, and Utility sector. Among specific types of falls to a lower level, falls from ladders represent 7.5 percent of all falls in the Manufacturing sector as reflected in an injury rate of 1.3 cases per 10,000 employees. Among other sectors, the injury rate from falls from ladders ranges from 0.4 per 10,000 employees in the Education and Health Services sector to 2.0 per 10,000 employees in the Trade, Transportation, and Utility sector and in the Other Services sector.

In several sectors, falls down stairs or steps represent a major share of injuries from falls to a lower level. The provisions in the final standard requiring guardrails, handrails, and training would protect employees from these types of falls. The final rule addresses directly falls from floor holes, loading docks, roofs, and scaffolding, but these falls constitute much smaller shares of nonfatal fall accidents.

3. Fatalities and Injuries Prevented by the Final Subpart D and I Standard

a. Fatalities Prevented

OSHA's final standard for subparts D and I contains safety requirements

designed to prevent falls involving ladders, rope descent systems, unguarded floor holes, and unprotected platform edges, among other conditions. In this FEA, OSHA classifies these types of falls as "falls to [a] lower level."

"Falls on the same level" include slips and trips from floor obstructions or wet or slippery working surfaces. The final rule has relatively few new provisions addressing falls on the same level and therefore OSHA has assigned a preventability rate of 1 percent (*i.e.*, the percentage of fatal incidents that the Agency estimates will be prevented by the final rule) to these types of falls.

Combining the data in Tables V-6 and V-7 with other fatality data from BLS, Table V-11 shows the estimated number of annual fatalities from falls in general industry. Based on 2006-2012 data, OSHA calculated an average of 345 fatal falls per year, 261 fatal falls to a lower level per year, and 75 fatal falls to the same level. OSHA allocated the average number of falls to a lower level (261) among the different fall categories based on overall fatal fall accident experience from 2006 to 2010 derived from the BLS *Census of Fatal Occupational Injuries*

summarized in table V-7.¹¹⁴ On this basis, an estimated 261 fatalities per year resulted from falls to a lower level, while the remaining 84 fatalities resulted from falls on the same level or other types of falls.

In examining the costs of the proposed standard, ERG found, after reviewing inspection results, that most employers are generally in compliance with the existing subpart D standards that have been in place for over 30 years (see Table V-15 in the PEA). However, this general compliance does not necessarily mean that many of the observed fall fatalities and injuries are not the result of failure to comply with existing standards. For example, even if employers are complying with a standard 99.9 percent of the time, it is still possible that many current fall fatalities could still be the result of the 0.1 percent level of employer noncompliance.

BILLING CODE 4510-29-P

¹¹⁴ See ERG, 2007 (Ex. OSHA-2007-0072-0046), p. 4-10, for further explanation of OSHA's methodology for applying historic percentages to types of falls. See also Ex. [OSHA Excel Workbook], tab Prevented Fatalities '06-'12 for details on the application of the distribution of falls from 2006-2010 to the baseline average number of fatal falls for 2006-2012 in the final benefits analysis.

Table V-11
Estimated Fatalities Prevented per Year by Compliance with the Final Standard

Type of Fall	2006-2010 Distribution of Fall to Lower Level by Type of Fall	Estimated Annual Number of Fatal Falls by Type	Incremental Prevention Resulting from Compliance with the Final Standard		Estimated Annual Fatalities Prevented by Final Standard[a]
Fall to lower level		261			
Fall down stairs or steps	7.7%[b]	20	Low	5.0%	1.0
Fall from floor, dock, or ground level	5.5%	14	High	10.0%	1.4
Fall from ladder	22.0%	57	High	20.0%	11.4
Fall from piled or stacked material	0.2%	1	High	10.0%	0.1
Fall from roof	9.8%	25	High	20.0%	5.1
Fall from scaffold, staging	5.2%	13	Very High	40.0%	5.4
Fall from building girders or other structural steel	1.7%	4	High	10.0%	0.4
Fall from nonmoving vehicle	22.3%	58	None	0.0%	0.0
Fall to lower level, n.e.c.	25.7%	67	Low	5.0%	3.4
Fall to lower level, unspecified	1.8%	3	Uncertain	2.5%	0.1
Fall on same level		75	Low	1.0%	0.7
Other falls (incl. ship, boat)		10	Low	2.5%	0.2
Totals	All Falls	345			29.0

Note: Due to rounding, figures may not sum to totals shown.

[a] Prevented fatalities calculated as the product of annual fatal falls and the incremental prevention rate, by type.

[b] Distribution percentages for this category and the nine categories below it are calculated as percentage of fall to a lower level.

Source: U.S. Department of Labor, OSHA, Directorate of Standards and Guidance, Office of Regulatory Analysis-Safety, based on Bureau of Labor Statistics, Census of Fatal Occupational Injuries, 2006-2012.

compliance with the existing standard could prevent. However, a qualitative examination of the fatal falls to a lower level shows that full and complete compliance with the existing standard could prevent a majority, and perhaps a large majority, of these falls. For the PEA, and for this FEA, OSHA and its contractor used expert judgment to estimate preventability factors associated with the new rule taking account of considerations that most falls might be prevented by existing rules. The preventability factors are then the percentage of existing falls, many of which are preventable by existing rules, that would be prevented by this new final rule. On the other hand, these preventability factors assume, as do the cost estimates, full compliance with the new rule. On the benefits side, the estimated number of preventable falls is based on estimates of the number of actual current falls that are preventable by full compliance with the new standard. On the cost side, costs are estimated as the cost of going from baseline compliance to full compliance with the new rule. In order to achieve consistency between costs and benefits estimates, both must reflect the same assumptions regarding existing compliance with the new rule.

OSHA also considered, and in some cases adopted, the approach of using consensus standards as a baseline. As will be discussed in detail in the cost chapter, in some cases OSHA assumed full compliance with consensus standards for purposes of both benefits and costs. In such cases, OSHA estimated neither costs nor benefits where the OSHA rule did not go beyond consensus standards. However, where consensus standards involve training or work practices required of even the smallest firms who may not even be aware of consensus standards, OSHA estimated both costs and benefits from the existing baseline. This baseline might yield overestimates of true impacts because many follow the consensus standard, but there is some reasonable chance that employers are more likely to meet an OSHA requirement than a consensus standard.

A comparison of the existing and new standards shows that the new provisions largely concern training and inspections, with requirements for additional or more stringent engineering or work-practice controls being less prominent (see Section F (Costs of Compliance) below in this FEA). Nonetheless, OSHA's final cost analysis assigns engineering controls and personal protective equipment to operations and activities that were not assigned such controls in the PEA,

including costs for repairs or replacements of equipment as a result of equipment failing inspections. In addition, the new standard simplifies and clarifies certain provisions, and, compared to the existing standard, better aligns them with various national consensus standards. OSHA finds that the benefits in terms of reductions in fatal falls result from increased training, inspections, and certifications (*i.e.*, roof anchor certification) in preventing falls.

In the PEA, OSHA based its analysis of accident prevention on ERG's professional judgment and two published studies.¹¹⁵ The studies show that well-designed training programs are an effective means of improving workplace safety. A review of the literature by the National Institute for Occupational Safety and Health concerning the benefits of training reported that the studies showed consistently that improved and expanded training increased hazard recognition and promoted adoption of safe work practices. However, the magnitude of the effect of increased training on accident rates remains uncertain (Cohen and Colligan, 1988). Further, analysis of past OSHA experience shows that requiring training programs does not ultimately prevent the majority of accidents addressed by the training. One study of OSHA benefits estimates for 6 standards promulgated between 1990 and 1999 found that OSHA had routinely estimated greater numbers of accidents potentially prevented than had actually occurred (Seong and Mendeloff, 2004). OSHA's accident prevention estimates ranged from 40 to 85 percent of relevant classes of accidents. The article shows that such levels of prevention did not in fact occur. The article goes on to discuss the issue of why effects were overestimated and states:

Why has OSHA usually overestimated the effects? One point that OSHA staff emphasized in response to these findings was that the figures they produce should not be viewed as "predictions;" rather, they are estimates of what the impact would be if there were full compliance with the standard.

OSHA staff is well aware that there is not full compliance with OSHA standards. However, despite its lack of realism, the assumption of full compliance seems generally reasonable given the task that the regulatory analysts face. OSHA is required by statute to demonstrate that its standards are technologically and economically feasible, and this demonstration must be made under the assumption that there is full compliance. And if costs are estimated under this assumption, then calculations of the benefits

these costs would generate should arguably use it as well.

However, there is a point at which the full compliance assumption does go beyond reasonableness. OSHA appears to assume that if a standard requires workers to avoid working in a hazardous manner or provides them training to change their behaviors, then all such unsafe behavior will be eliminated. This assumption creates the potential for estimating unrealistically large reductions in injuries. When training and work practices are major components of a standard, OSHA should be required to analyze their impacts in a more deliberative and realistic fashion. (Seong and Mendeloff, 2004)

OSHA continues to feel it is important to present full compliance estimates, but agrees with the article that such an assumption should not imply that the training can be expected to prevent accidents as if all lessons provided in training are automatically applied by all workers.

In addition to less than full compliance, there are some methodological limitations to the time trend approach used by Seong and Mendeloff. First they assume that compliance begins on the effective date of the regulation. In reality, some employers begin compliance with new regulations before they are finalized, while others do not start to comply until long after a regulation goes into effect. Many employers start applying many of the provisions of a proposed standard at the time of proposal, in part to get ahead of the curve; to the extent their change in practices is anticipatory of OSHA setting or revising standards, it should be attributed to the OSHA policy. Other employers do not respond to a regulation as soon as it is promulgated. OSHA itself frequently lets employers off with a warning rather than citation in the first year of enforcement of a standard. Finally there is a surprising amount of year-to-year variation in fatality data which create a great deal of noise that makes the effects of rules difficult to interpret. Seong and Mendeloff analyze the results of OSHA analyses from 17 to 27 years ago. OSHA personnel are acknowledged in the articles credits, and OSHA has continued to believe that OSHA should take account of this article in its benefits analysis. In order to assure that this was done, OSHA has shared this concern with its contractors where appropriate. As a result of consideration of this article, OSHA has made clear that reviewers of safety benefits analysis would apply certain principles in their review. First, expert analysts were informed on past overestimates, with the hope that experts would gain in accuracy from feedback on their past inaccuracies and biases. Secondly,

¹¹⁵ The term "prevention rate" as used in this FEA, refers to prevention of both injuries and fatalities.

benefits analyses should not assume that changes in training requirements can be expected to have large changes in incident prevented unless there are also changes in engineering controls or strong prohibitions on practices. Third, the higher the estimate, the greater would be the justification required beyond stating this was the best judgment of the experts. One possible effect of applying these principles is that the highest preventability factor that was applied in the PEA was lower than the lowest preventability factors in the studies the Seong and Mendeloff (2004) article reviewed.

A second major issue is that the failure of OSHA regulations to achieve the anticipated benefits maybe partly due to failure of employers to comply with the regulations. As noted by Seong and Mendeloff, OSHA routinely assume full compliance with regulations for legal reasons. In some cases, if compliance is lower than 100 percent, benefits and costs will be proportionally reduced, with no effect on whether benefits exceed costs. For example, if twenty percent of establishments in an industry are out of compliance with a provision in the baseline, and these twenty percent cause ten percent of all fall fatalities, then if only ten percent come into compliance, rather than twenty percent, accidents would still be reduced by five percent. Under this scenario, a finding that benefits exceed costs under full compliance would be maintained at a lower compliance level, as long as those out of compliance are a homogeneous group.

There is, however, the possibility that those out of compliance are not a homogeneous group but consist of the two subgroups, one of which has found other ways of preventing the same kind of falls, and one of which are “bad actors” who make no efforts of any kind to prevent falls. In this case, if compliance is only by those in the safer group, the effects of noncompliance would not simply be proportional. Such a situation might be particularly likely if there is noncompliance with an existing rule and OSHA adds provisions designed to assure greater compliance. For example, almost all trenching fatalities are the result of complete failure to comply with existing shoring requirements. An attempt to improve compliance by increasing recordkeeping, training, and certification might have little effect on the bad actors who simply fail to use shoring at all while imposing additional costs on those already following existing shoring requirements. If only those in compliance with the existing rule also follow these new provisions, then there

would be costs without benefits. OSHA has reviewed this rule and does not believe that this is the case for the provisions of this rule.

Because of the importance of this issue, OSHA examines the effects of possible overestimation of benefits and of noncompliance on both costs and benefits in the sensitivity analysis.

For the PEA, OSHA estimated the number of fatal falls potentially prevented by compliance with the proposed standard, categorized by type of fall. Since proposed subpart D focused heavily on ladder safety, OSHA judged the highest impact—15 percent—would be in preventing fatal falls from ladders. For other types of fatal falls directly addressed in the proposal (*e.g.*, falls from floor or dock), OSHA judged a more moderate impact of 10 percent. For other types of fatal falls (*e.g.*, falls down stairs or steps), OSHA judged a relatively low prevention impact (5 percent). For the several types of fatal falls not specifically defined by the BLS injury survey (fall to lower level, *n.e.c.*, and fall to lower level, unspecified), OSHA judged a level of preventability (2.5 percent). (See the PEA (Ex. 1) and ERG, 2007 (Ex. 46), pp. 4–10 to 4–14.)

For falls from roofs, OSHA judged in the PEA that compliance with the provisions in proposed subpart D addressing safety systems, work practices, and training associated with the fall hazards encountered on roof surfaces—including the requirements referenced in national consensus standards such as ANSI/ASSE A1264.1–2007, Safety Requirements for Workplace Walking/Working Surfaces and Their Access; Workplace, Floor, Wall and Roof Openings; Stairs and Guardrail Systems—would result in a prevention rate of 15 percent. Therefore, in the preliminary analysis of benefits, OSHA applied a prevention rate of 15 percent to roof accidents.

For this final analysis of benefits, OSHA increased the prevention rate for roofs to 20 percent because the final standard: (1) Significantly strengthened fall protection for chimney sweeps (see Section F Costs of Compliance below in this FEA for a discussion of the control measures that OSHA used for the chimney-cleaning services industry), and (2) in greater detail, through association with an analogous standard for construction, extended fall protection in the form of designated areas and work rules intended to limit the movement of workers to within 15 feet of the roof edge when fall protection is not installed and available for use (see Section F below for a discussion of fall protection on rooftops across industries

covered by § 1910.28, Duty to have fall protection). OSHA’s final analysis of compliance costs for rooftop inspections addressed by final § 1910.28(b)(13), Work on low-slope roofs, includes costs for the installation of fall-arrest anchorages for the small percentage of inspections that identify hazardous conditions at or near roof edges (see discussion in the section “Cost Estimates”, below). These additional rooftop inspections and fall-system enhancements are expected to contribute to the benefits of reduced fatalities and injuries.

Two chimney-sweep accidents reported in OSHA’s IMIS database (OSHA, 2012a) illustrate the benefits achievable under the final standard. In the first accident (Inspection No. 311734842), an employee of a Maryland chimney-sweep business died from impact injuries to the head and neck after apparently falling 15 feet. Although no one witnessed the accident, it appears, based on evidence at the scene and an interview with the homeowner, that the employee was using a 12-foot section of a ladder to gain access to three roof levels: the primary roof, the porch roof, and the roof peak. Inspectors found no roof perimeter guardrail or anchorage-based personal fall protection equipment at the site. OSHA believes the final standard at § 1910.28 would prevent such a fall because the employer would have to provide fall protection for an employee exposed to a height of four feet or greater.

In a second chimney-cleaning accident identified by OSHA (Inspection No. 307309054), employees of an air-duct and chimney-service company were installing a protective cap on a chimney. One of the employees was using a 2-foot stepladder leaning against the chimney chase to access the top of the chimney when he fell 24 feet. OSHA’s investigation of the fatality showed that the employee was not using personal fall protection equipment, a safety measure required by the final standard.

For this final analysis of benefits, OSHA increased the prevention rate for ladders to 20 percent (from 15 percent in the PEA) because the requirement in the final rule for safety systems on all fixed ladders, including outdoor advertising, will substantially reduce the number of ladder-related accidents.

In addition, OSHA believes that the increased level of worker training on ladder safety systems required by the final rule, and the heightened recognition of the fall hazards associated with ladder safety systems resulting from this training, will yield a

higher percentage of accident avoidance than preliminarily estimated by the Agency in the PEA.

OSHA also increased the prevention rate for falls to lower level, not elsewhere classified, to 5 percent (from 2.5 percent in the PEA) based on the requirements for step bolts in the final rule. OSHA revised its preliminary estimate of the prevention rate based on its determination that employers will increase use of ladder safety systems combined with personal fall protection on structures covered by the final rule that currently use only step bolts or ladders without ladder safety systems, such as pole-mounted lights at sports and performance arenas and other tall structures.

For falls from scaffolds or staging, OSHA judged a prevention rate of 40 percent in the PEA. No commenters raised objections to this estimate, so OSHA retained it for this FEA. OSHA believes that this estimate is reasonable because, according to OSHA and BLS accident data, approximately 40 percent of lost-workday scaffold accidents involve rope-descent systems. Therefore, in view of the final standard's comprehensive coverage of

these systems, OSHA believes that it is reasonable to expect that the final standard will prevent at least 40 percent of deaths and injuries associated with scaffolds.

In addition, Table V-11 shows that falls from scaffolds or staging is a leading category of falls in general industry. According to the Bureau of Labor Statistics, such falls caused an average of 18 deaths and 1,474 lost-workday injuries yearly over a recent eleven-year period (1992-2002). For the PEA, OSHA reviewed a subset of scaffold accidents recorded in the Agency's Integrated Management Information System (IMIS) database to expand ERG's analysis of the extent to which the proposed standard would prevent accidents involving commercial window cleaning to gain additional information on prevention of fatal falls (OSHA, 2009). Accordingly, OSHA reviewed 36 incidents (some involving multiple casualties) that occurred during the period January 1995 to October 2001 in which a fall from an elevated scaffold or a similar surface during commercial window cleaning operations either killed or injured

workers in general industry. OSHA then applied expert judgment to make determinations about which of these incidents would be preventable by full compliance with each of the following standards:

1. The existing standard for walking-working surfaces;

2. A 1991 memorandum to regional administrators that describes the safe use of descent-control devices (*i.e.*, rope-descent systems or RDSs) by employees performing building exterior cleaning, inspection, and maintenance (OSHA, 1991a), which were incorporated into ANSI/IWCA I-14.1, Window Cleaning Safety Standard; or

3. The final standard.

Table V-12 below summarizes OSHA's analysis of the IMIS window cleaning incidents. Table V-12 shows that the existing standard did not account for incidents in three of the four cause-of-incident categories. The existing standard could not account for these incidents because it has no provisions that directly regulate RDSs. Accordingly, OSHA believes that full compliance with the existing standard would not prevent these incidents.

Table V-12

Fall Incidents Associated with the Use of Scaffolds during Window Cleaning

Cause of Incident	Incidents Prevented by:[a]		
	Existing Standard	OSHA 1991 Memo	Final Standard
Malfunction/Mishandling of Rope Descent System or Lifelines	NA[b]	19	21
Anchorage Failure	NA	7	8
Inadequate Training	NA	12	14
Other Factors (suspension scaffold hardware, manlift, powered platform, roof top equipment, safety belt)	5	NA	6
Number of incidents believed to be preventable	5	20	36

[a]OSHA assigned some incidents to more than one standard because provisions in the standards provided similar fall protection.

[b]NA: No provision in the document addressing this cause.

Source: U.S. Department of Labor, OSHA, Directorate of Standards and Guidance.

The 21 RDS incidents in the category titled “Malfunction/Mishandling of Rope Descent System or Lifelines” typically involved a malfunction in, or unsafe use of, an RDS rope descent systems (including lifelines). OSHA determined that safety conditions specified in its 1991 memorandum could prevent 19 of these incidents. The final rule could prevent these 19 RDS incidents, as well as the remaining two RDS incidents. As noted earlier, OSHA’s existing subpart D would not prevent any of the RDS incidents in this category.

One of the primary causes of accidents in commercial window cleaning is the failure of the rooftop anchorage to support the suspended scaffold, the second cause-of-incident category in Table V–12. The final standard requires that employers use proper rigging, including sound anchorages and tiebacks, with RDS. OSHA identified eight incidents in the IMIS database for which anchorage failure contributed to the incident. In OSHA’s judgment, all eight anchorage-related incidents involved factors addressed by the final standard and, therefore, would be preventable under that standard. All but one of these eight incidents involved factors addressed by the 1991 OSHA memo.

The third cause-of-incident category in Table V–12 addresses accidents that are less likely to occur when employers train workers adequately—for example, in the proper use of harnesses and lifelines. OSHA identified 14 incidents in the IMIS database in which death or injury to a worker would be preventable had the worker applied the training required by the final standard. Of these 14 cases, 12 involved factors addressed by the 1991 OSHA memo.

Other factors that led to a fall from elevation, such as equipment failure involving suspension scaffolds and powered platforms, contributed to the death or injury of workers during window cleaning operations. The fourth cause-of-incident category in Table V–12 addresses these incidents. OSHA determined that provisions in the existing standard would prevent four of these incidents, while the provisions of the final standard would prevent six of them. The 1991 OSHA memo had no provisions that would prevent these incidents.

OSHA believes that this analysis illustrates some of the complexities in assigning benefits to the final standard. Chief among these complexities is the assumption that full compliance with the final standard will prevent fatalities not preventable by the existing standard due to the addition in the final standard

of major requirements addressing window cleaning operations.

Second, there is the question of the proper baseline for such an analysis. Prior to publication of the final standard, while OSHA did not have a rule addressing RDSs or anchorages for these systems and suspended scaffolds, OSHA could use national consensus standards and enforcement policies, in concert with the general duty clause, to prompt employers to prevent falls to lower levels. Therefore, reductions in fall-related incidents likely occurred as a result of this enforcement practice, even if OSHA applied this practice irregularly. However, OSHA has not treated the 1991 memo as the baseline for either benefits or costs, but has instead estimated costs for most activities required by the 1991 memo and benefits from the current levels of compliance.

Third, there is the issue, already discussed, of how to treat the benefits of training requirements. OSHA normally assumes full compliance with a rule for the purposes of both benefit and cost analysis. For some provisions in a rule, the Agency can readily determine whether full compliance with the rule would prevent an incident. However, for training provisions, it is difficult to determine whether full compliance with the training requirements would prevent the incidents the training is addressing (Seong and Mendeloff, 2004). OSHA’s resulting estimate of the effects of the training requirements is specified by Table V–11. According to OSHA’s determinations summarized in Table V–12, adequate training, if the instructions in training were followed, could have prevented up to 14 of the 36 window cleaning fall-related incidents reported in IMIS.

Based on the PEA and the rulemaking record, and applying the fatality-prevention rate for scaffolds explained above, OSHA concludes that the final standards will prevent 29 fall fatalities a year, *i.e.*, the final standards would prevent approximately 8 percent of the fatal falls in general industry.

b. Injuries Prevented

For the purposes of estimating the number of lost-workday injuries prevented by the final standards, OSHA applied the same prevention factors to lost-workday injuries that it assigned to the defined categories of fatal falls. Table V–13 shows, by type of fall, the distribution of lost-workday injuries for general industry; these injury categories duplicate the categories in Table V–8. The BLS data show that, for non-fatal falls to a lower level, 30.4 percent of injuries are due to falls down stairs or

steps, while 22.3 percent are the result of falls from ladders. Averaging total lost-workday fall injuries for 2006–2012, OSHA estimates that 202,066 lost-workday fall injuries occur each year for work operations directly affected by the final revisions to subparts D and I (see Ex. [OSHA Excel Workbook], tabs Injury Fall % 2006–2012 and Prevented Injuries ‘06–’12).

For this FEA, OSHA notes a significant addition to its preliminary analysis of benefits. In the PEA, OSHA primarily focused on the benefits of preventing falls to a lower level because of the relatively greater certainty of accident avoidance associated with the required control strategies that OSHA anticipates employers will apply to ladders, scaffolds, rope descent systems, roofs, and other elevated surfaces after the Agency issues the final rule. However, based on testimony in the record (Exs. 329 (1/20/2011, pp. 42, 60–61); 329 (1/21/2011, pp. 200–203); 330), OSHA expanded its analysis to include the benefits of preventing slips, trips, and falls on the same level. As shown in Table V–8, 2006–2012 BLS data indicate that falls on the same level resulted in 137,079 lost-workday injuries in work activities in general industry affected by the final rule. OSHA estimates that the provisions of final subpart D addressing general conditions (§ 1910.22) will prevent 1 percent of these accidents, or 1,371 injuries. The 1% prevention rate assumes that the time employers will expend to inspect (two hours per year) and correct hazards (20 minutes for the 10 percent of establishments with unsafe conditions) in compliance with 1910.22(d) will lead to this reduction. This estimate is uncertain, and we examined other prevention rates in our sensitivity analysis.¹¹⁶

Using the prevention estimates described above for falls on the same level and the prevention estimates applied to fatal incidents involving falls to a lower level, OSHA estimates that compliance with final subparts D and I will prevent 5,842 lost-workday fall injuries annually. OSHA recognizes that this prevented-injuries estimate is a 58 percent increase over the preliminary estimate (*i.e.*, 3,706 prevented injuries); however, OSHA believes that this estimate accurately captures the full range of accidents that the final rule addresses.

BILLING CODE 4510–29–P

¹¹⁶ Other sections of the standard may indirectly prevent falls on the same level.

Table V-13
Estimated Lost-Workday Injuries per Year Prevented by Compliance with
Final Subparts D and I

Type of Fall	Distribution of Falls Resulting in Lost Workdays by Type	Estimated Annual Number of Nonfatal Falls by Type	Incremental Prevention Resulting from Compliance with the Final Standards		Estimated Annual Injuries Prevented by the Final Standards[a]
Fall to lower level	24.0%	48,379			
Fall down stairs or steps	30.4%[b]	14,726	Low	5.0%	736
Fall from floor, dock, or ground level	8.2%	3,987	High	10.0%	399
Fall from ladder	22.3%	10,805	High	20.0%	2,161
Fall from piled or stacked material	0.8%	370	High	10.0%	37
Fall from roof	0.9%	429	High	20.0%	86
Fall from scaffold, staging	1.2%	597	Very High	40.0%	239
Fall from building girders or other structural steel	0.3%	134	High	10.0%	13
Fall from nonmoving vehicle	19.0%	9,188	None	0.0%	0
Fall to lower level, n.e.c.	14.9%	7,230	Low	5.0%	362
Fall to lower level, unspecified	1.9%	921	Uncertain	2.5%	23
Fall on same Level	67.8%	137,079	Very Low	1.0%	1,371
Other falls (incl. ship, boat)	8.2%	16,609	Uncertain	2.5%	415
Totals	100.0%	202,066			5,842

Note: Due to rounding, figures may not sum to totals shown.

[a]Prevented injuries calculated as the product of annual nonfatal falls and the incremental prevention rate, by type.

[b] Distribution percentages for this category and the nine categories below it are calculated as percentage of fall to a lower level. Distribution percentage for fall on same level and other falls are calculated as percentage of total falls in general industry.

Source: U.S. Department of Labor, OSHA, Directorate of Standards and Guidance, Office of Regulatory Analysis-Safety, based on Bureau of Labor Statistics, Survey of Occupational Injuries and Illnesses: Case and Demographic Information, 2006-12.

</PHOTO>

4. Nonquantifiable Benefits

As noted earlier in this FEA, OSHA did not estimate the improvements in the efficiency of compliance associated with clarifying the existing rule and

making it consistent with current national consensus standards. In addition to the benefits associated with those factors, OSHA anticipates that improvements to its walking-working surfaces standard in general industry

will yield further benefits. In the following exhibit and in the discussion that follows, OSHA highlights the key substantive differences introduced by the final rule.

4. Nonquantifiable Benefits

Exhibit V-2: Revised Subparts D&I and Existing Standards for Fall Protection in General Industry – Key Substantive Differences		
Existing Standard (Subpart D, unless otherwise indicated)	Revised Standard	Comment
<p>§1910.22 General requirements, paragraph (a)(3) "Housekeeping." requires that every floor, working place, and passageway shall be kept free from protruding nails, splinters, holes, or loose boards.</p>	<p>§1910.22 General requirements, paragraph (a)(3) Surface conditions, requires that the employer ensure that walking-working surfaces are maintained free of hazards such as sharp or protruding objects, loose boards, corrosion, leaks, spills, snow, and ice.</p>	<p>Expanded list will strengthen employer duty to maintain hazard-free surfaces.</p>

**Exhibit V-2: Revised Subparts D&I and Existing Standards for Fall Protection in General Industry –
Key Substantive Differences (continued)**

Existing Standard (Subpart D, unless otherwise indicated)	Revised Standard	Comment
Consensus standards only.	<p>§ 1910.24 Step bolts and manhole steps, paragraph (a)(1) Step bolts, requires that the employer ensure that each step bolt installed on or after January 17, 2017 in an environment where corrosion may occur is constructed of, or coated with material that protects against corrosion.</p> <p>§ 1910.24 Step bolts and manhole steps, paragraph (b)(2) Manhole steps, requires the employer must ensure that each manhole step installed on or after January 17, 2017</p> <ul style="list-style-type: none"> • has a corrugated, knurled, dimpled, or other surface that minimizes the possibility of an employee slipping; and • is constructed of, or coated with, material that protects against corrosion if the manhole step is located in an environment where corrosion may occur. 	New section addresses hazards of unsafe step bolts and manhole steps.
Consensus standards only.	<p>§1910.27 Scaffolds and rope descent systems, paragraph (b)(1) Rope descent systems, requires that before any rope descent system is used, the building owner must inform the employer, in writing, that the building owner has identified, tested, certified, and maintained each anchorage so it is capable of supporting at least 5,000 pounds (268 kg) in any direction, for each employee attached. The information must be based on an annual inspection by a qualified person and certification of each anchorage by a qualified person, as necessary, and at least every 10 years. Paragraph (b)(ii) in that section requires that the employer must ensure that no employee uses any anchorage before the employer has obtained written information from the building owner that each anchorage meets the requirements of paragraph (b)(1)(i) of this section. The employer must keep the information for the duration of the job.</p>	New provision specifies requirement for building anchorage certification and inspection for use of suspended scaffolds.

**Exhibit V-2: Revised Subparts D&I and Existing Standards for Fall Protection in General Industry –
Key Substantive Differences (continued)**

Existing Standard (Subpart D, unless otherwise indicated)	Revised Standard	Comment
<p>Generally consensus standards only, except:</p> <p>§1910.28 Safety requirements for scaffolding, paragraph (a)(21) “General requirements for all scaffolds”, requires that only treated or protected fiber rope shall be used for or near any work involving the use of corrosive substances or chemicals.</p>	<p>§1910.27 Scaffolds and rope descent systems, paragraph (b)(2) Rope descent systems, requires that the employer ensure:</p> <ul style="list-style-type: none"> • that no rope descent system is used for heights greater than 300 feet (91 m) above grade unless the employer demonstrates that it is not feasible to access such heights by any other means or that those means pose a greater hazard than using a rope descent system; • that the rope descent system is used in accordance with instructions, warnings, and design limitations set by the manufacturer or under the direction of a qualified person; • that each employee who uses the rope descent system is trained in accordance with §1910.30; • that the rope descent system is inspected at the start of each workshift that it is to be used. The employer must ensure damaged or defective equipment is removed from service immediately and replaced; • that the rope descent system has proper rigging, including anchorages and tiebacks, with particular emphasis on providing tiebacks when counterweights, cornice hooks, or similar non-permanent anchorages are used; and • that each employee uses a separate, independent personal fall arrest system that meets the requirements of 29 CFR part 1910, subpart I. 	<p>New RDS section codifies consensus standard and best practices.</p>

**Exhibit V-2: Revised Subparts D&I and Existing Standards for Fall Protection in General Industry –
Key Substantive Differences (continued)**

Existing Standard (Subpart D, unless otherwise indicated)	Revised Standard	Comment
<p>Generally consensus standards only, except:</p> <p>§1910.28 Safety requirements for scaffolding, paragraph (a)(21) “General requirements for all scaffolds” requires that only treated or protected fiber rope shall be used for or near any work involving the use of corrosive substances or chemicals.</p>	<p>§1910.27 Scaffolds and rope descent systems, paragraph (b)(2) Rope descent systems, requires that the employer must ensure:</p> <ul style="list-style-type: none"> • that all components of each rope descent system, except seat boards, are capable of sustaining a minimum rated load of 5,000 pounds (22.2 kN). Seat boards must be capable of supporting a live load of 300 pounds (136 kg); • that prompt rescue of each employee is provided in the event of a fall; • that the ropes of each rope descent system are effectively padded or otherwise protected, where they can contact edges of the building, anchorage, obstructions, or other surfaces, to prevent them from being cut or weakened; • that stabilization is provided at the specific work location when descents are greater than 130 feet (39.6 m); • that no employee uses a rope descent system when hazardous weather conditions, such as storms or gusty or excessive wind, are present; • that equipment, such as tools, squeegees, or buckets, is secured by a tool lanyard or similar method to prevent it from falling; and • that the ropes of each rope descent system are protected from exposure to open flames, hot work, corrosive chemicals, and other destructive conditions. 	<p>New RDS section codifies consensus standard and best practices.</p>

**Exhibit V-2: Revised Subparts D&I and Existing Standards for Fall Protection in General Industry –
Key Substantive Differences (continued)**

Existing Standard (Subpart D, unless otherwise indicated)	Revised Standard	Comment
<p>§1910.27 Fixed ladders, paragraph (d)(2) “Special requirements” requires that when ladders are used to ascend to heights exceeding 20 feet (except on chimneys), landing platforms must be provided for each 30 feet of height or fraction thereof, except that, where no cage, well, or ladder safety device is provided, landing platforms must be provided for each 20 feet of height or fraction thereof. In addition, each ladder section shall be offset from adjacent sections. Where installation conditions (even for a short, unbroken length) require that adjacent sections be offset, landing platforms must be provided at each offset.</p>	<p>§1910.28 Duty to have fall protection., paragraph (b)(9) <u>Fixed ladders</u>, requires that for fixed ladders that extend more than 24 feet (7.3 m) above a lower level, the employer must ensure:</p> <ul style="list-style-type: none"> • that each fixed ladder installed before November 19, 2018 is equipped with a personal fall arrest system, ladder safety system, cage, or well; • that each fixed ladder installed on or after November 19, 2018, is equipped with a personal fall arrest system or a ladder safety system; • that when a fixed ladder, cage, or well, or any portion of a section thereof, is replaced, a personal fall arrest system or ladder safety system is installed in at least that section of the fixed ladder, cage, or well where the replacement is located; and • That on and after November 18, 2036, all fixed ladders are equipped with a personal fall arrest system or a ladder safety system. 	<p>In outdoor advertising and other industries where fixed ladders are climbed frequently, additional protection provided at heights above 24 ft.</p>

Exhibit V-2: Revised Subparts D&I and Existing Standards for Fall Protection in General Industry – Key Substantive Differences (continued)		
Existing Standard (Subpart D, unless otherwise indicated)	Revised Standard	Comment
	<p>§1910.28 Duty to have fall protection, paragraph (b)(13) <u>Work on low-slope roofs</u>, requires:</p> <ul style="list-style-type: none"> • that when work is performed less than 6 feet (1.6 m) from the roof edge, the employer must ensure each employee is protected from falling by a guardrail system, safety net system, travel restraint system, or personal fall arrest system; • that when work is performed at least 6 feet (1.6 m) but less than 15 feet (4.6 m) from the roof edge, the employer must ensure each employee is protected from falling by using a guardrail system, safety net system, travel restraint system, or personal fall arrest system. The employer may use a designated area when performing work that is both infrequent and temporary; and • that when work is performed 15 feet (4.6 m) or more from the roof edge, the employer must: (1) protect each employee from falling by a guardrail system, safety net system, travel restraint system, or personal fall arrest system, or a designated area. The employer is not required to provide any fall protection provided the work is both infrequent and temporary; and (2) implements and enforces a work rule prohibiting employees from going within 15 feet (4.6 m) of the roof edge without using fall protection in accordance with paragraphs (b)(13)(i) and (ii) of this section. The employer is not required to provide any fall protection provided the work is both infrequent and temporary. 	<p>New provision addresses risks on low-slope roofs.</p>

**Exhibit V-2: Revised Subparts D&I and Existing Standards for Fall Protection in General Industry –
Key Substantive Differences (continued)**

Existing Standard (Subpart D, unless otherwise indicated)	Revised Standard	Comment
	<p>§1910.30 Training requirements, paragraph (a)(1) <u>Fall hazards</u> requires that before any employee is exposed to a fall hazard, the employer must provide training for each employee who uses personal fall protection systems or who is required to be trained as specified elsewhere in this subpart. Moreover, employers must ensure employees are trained in the requirements of this paragraph on or before May 17, 2017.</p> <p>Paragraph (a)(2) of that section requires the employer must ensure that each employee is trained by a qualified person. Paragraph (a)(3) of that section requires the employer to train each employee in at least the following topics:</p> <ul style="list-style-type: none"> (i) The nature of the fall hazards in the work area and how to recognize them; (ii) The procedures to be followed to minimize those hazards; (iii) The correct procedures for installing, inspecting, operating, maintaining, and disassembling the personal fall protection systems that the employee uses; and (iv) The correct use of personal fall protection systems and equipment specified in paragraph (a)(1) of this section, including, but not limited to, proper hook-up, anchoring, and tie-off techniques, and methods of equipment inspection and storage, as specified by the manufacturer. <p>§1910.30 Training requirements, paragraphs (b)(1), requires that the employer train each employee on or before May 17, 2017 in the proper care, inspection, storage, and use of equipment covered by this subpart before an employee uses the equipment.</p> <p>Paragraph (b)(2) of that section requires the employer train each employee who uses a dockboard to properly place and secure it to prevent unintentional movement.</p> <p>Paragraph (b)(3) of that section requires the employer train each employee who uses a rope descent system in proper rigging and use of the equipment in accordance with §1910.27.</p> <p>Paragraph (b)(4) of that section requires the employer train each employee who uses a designated area in the proper set-up and use of the area.</p>	<p>New requirements for training on fall and equipment hazards ensure communication on, and remediation of hazards.</p>

Exhibit V-2: Revised Subparts D&I and Existing Standards for Fall Protection in General Industry – Key Substantive Differences (continued)		
Existing Standard (Subpart D, unless otherwise indicated)	Revised Standard	Comment
<p>§1910.132 General Requirements, paragraph (d)(1) Hazard assessment and equipment selection, requires that the employer assess the workplace to determine if hazards are present, or are likely to be present, which necessitate the use of personal protective equipment (PPE). If such hazards are present, or likely to be present, the employer must:</p> <ul style="list-style-type: none"> • select, and have each affected employee use, the types of PPE that will protect the affected employee from the hazards identified in the hazard assessment; • communicate selection decisions to each affected employee; and, • select PPE that properly fits each affected employee. <p>Note: Non-mandatory Appendix B contains an example of procedures that would comply with the requirement for a hazard assessment.</p> <p>Paragraph (d)(2) of that section requires that the employer shall verify that the required workplace hazard assessment has been performed through a written certification that identifies the workplace evaluated; the person certifying that the evaluation has been performed; and the date(s) of the hazard assessment. The written certification must be identified as the document certifying the hazard assessment.</p>	<p>Hazard Assessment requirements in Subpart I are now applied to fall protection PPE.</p>	

Source: U.S. Department of Labor, OSHA Directorate of Standards and Guidance, Office of Regulatory Analysis-Safety.

Earlier in this preamble, in the summary and explanation of final § 1910.28 Duty to have fall protection and falling-object protection, OSHA described the means by which the final standard provides greater flexibility in controls than is found in the current walking-working standard for preventing slip, trip, and fall accidents. OSHA believes that expanding control flexibility will produce nonquantifiable benefits, and in the following discussion, the Agency reiterates the factors that will help generate the nonquantified benefits supplementing the quantified benefits shown in Impacts Exhibit V-1 and in Tables V-11 and V-13 in this FEA.

This rule, like the construction fall protection standard, allows general industry employers, similar to construction employers, to protect workers from falls hazards by choosing from a range of acceptable fall protection options. The existing general industry standard, however, mandated the use of guardrail systems as the primary fall protection method (*e.g.*, see existing § 1910.23(c)).

The 1990 proposed revision of subpart D continued to require the use of guardrail systems. However, in the 2003 notice reopening the record, OSHA acknowledged that it may not be feasible to use guardrails in all workplace situations (68 FR 23528, 23533 (5/2/2003)) and requested comment on whether the Agency should allow employers to use other fall protection systems instead of guardrails. Commenters overwhelmingly favored this approach, which the construction fall protection standard adopted in 1994. In response to comments and OSHA's history and experience with the construction fall protection standard, the Agency proposed allowing employers to select from a range of fall protection options instead of requiring employers to comply with the existing mandate to use guardrail systems.

OSHA is adopting the proposed approach for several reasons. First, OSHA believes giving general industry employers flexibility in selecting fall and falling-object protection systems allows them to select the system or method that they determine will work best for the particular work operation and location. Such flexibility allows employers to consider factors such as exposure time, availability of appropriate attachment points, feasibility, cost effectiveness, and cost constraints when selecting the appropriate fall protection system for the work activity.

Second, providing control flexibility allows general industry employers to

take advantage of advances in fall protection technology developed since OSHA adopted the existing rule. The existing rule, by contrast, limited choices in fall protection technology.

Third, making the final rule consistent with the construction standard ensures that employers who have workers engaged in both general industry and construction activities are able to use the same fall and falling-object protection while performing both types of activities. It eliminates the need to purchase different fall protection systems when their workers perform general industry operations. Thus, making the general industry and construction rules consistent ensures that final rule is a cost-effective approach for reducing significant risk of harm. As a result, OSHA believes that the additional flexibility and consistency achieved by this final rule in providing fall protection will reduce worker deaths and injuries.

OSHA believes the comprehensive approach to fall protection (that is, duty to provide fall protection, mandatory criteria for controls, regular inspections, and training) that the final rule and the construction fall protection standard incorporate will provide equivalent or greater protection than the existing rule. In addition, the greater flexibility the final rule affords employers will allow them to select the fall protection option that works best in the specific situation and is the most cost-effective protective measure capable of reducing or eliminating significant risk of harm. Moreover, the comprehensive approach in the final rule, like the construction fall protection standard, recognizes that, in some instances, it may not be possible to use guardrail systems or other passive controls to protect workers from falls. For example, employers may not be able to install permanent systems such as guardrails when they do not own the building or structure on which their employees are working. OSHA believes the final rule addresses the concerns of these commenters without limiting employer flexibility or compromising worker safety.

As mentioned, the final rule limits fall protection choices in some situations where the Agency determined that passive/permanent systems provide the requisite level of protection. For example, in final paragraph (b)(5), OSHA specifically requires the use of guardrails on runways and similar walkways. Likewise, guardrail systems or travel restraint systems are the only systems that employers may use to protect workers on slaughter-house platforms (see final paragraph (b)(14)). In these cases, OSHA limited

employers' choices to those systems that are possible to use on those walking-working surfaces and that provide an adequate and appropriate level of safety.

The final rule also establishes criteria and work practices addressing personal fall protection systems (§ 1910.140). These criteria include minimum strength and load, locking, and compatibility requirements for components of personal fall protection systems, such as lines (vertical lifelines, self-retracting lines, travel restraint lines), snaphooks, and anchorages. The work practices include requiring employers to ensure inspection of personal fall protection systems before the initial use during each work shift, and to ensure that a competent or qualified person inspects each knot in a lanyard or vertical lifeline. OSHA believes that these criteria and work practices, in conjunction with the training and retraining requirements in the final rule, provide a combination of controls and redundancies that will help to ensure that personal fall protection systems are effective in protecting workers from falls hazards.

c. Public Comment on Benefits

OSHA requested comment on the Agency's preliminary analysis of the scaffold accidents described above, and on the various approaches used to determine the estimated benefits achievable from compliance with the other provisions of the proposed standard. The following discussion presents OSHA's summary of the public comments received on OSHA's preliminary benefits analysis.

The National Chimney Sweep Guild (NCSG) questioned the benefits of a fall protection system that involved the use of an anchorage, travel restraint lines, and harnesses for repair and maintenance activities on a residential roof:

Given that the average time on the roof for a typical chimney service is between five and twenty minutes, we believe it is clear that the installation of a single roof anchor (taking 45 to 90 minutes) would expose the chimney sweep to greater hazards for a longer period of time. Installation of the anchor requires extra equipment to be taken to the roof, and increases the number of ground to roof trips. We believe one of the highest hazards is the ladder to roof transition, both getting onto and off of the roof. The work required to install the roof anchor(s) would significantly increase the number of ladder to roof to ladder transition cycles. Furthermore, the anchor would not provide any fall protection during the period before the sweep could attach to it or during the period after the sweep detached from it.

In conclusion, the installation of a roof anchor point roughly equals the cost of an

average chimney cleaning or inspection service, requires significantly more ladder to roof to ladder transitions, keeps the technician working on the roof for a substantially longer period of time than would be required to perform the average chimney cleaning or inspection service, and would not provide fall protection for the ladder to roof and roof to ladder transitions. Accordingly, we believe it is clear that it is economically infeasible (in the rare circumstance where it would be acceptable to a homeowner) and would expose the technician to a greater hazard to require the installation of the anchor(s) that would be necessary to use a personal fall arrest system, a travel restraint system or a safety net while performing the great majority of the tasks performed by sweeps (Ex. 150, pp. 30–31).

In this quotation, NCSG argued that, in many cases, the installation of a roof anchor would involve greater hazard, and challenged OSHA's determination that it is feasible to apply these fall protection systems for chimney or other roof work.

With respect to the issue of greater hazard, while some chimney sweep jobs are relatively short (e.g., chimney cleaning and inspection, minor repairs), some are much longer than five to 20 minutes (e.g., substantial and major installations and repairs) (Exhibit 150). A simple chimney cleaning job typically involves no time on the roof except possibly a short inspection of the exterior of the chimney after the cleaning is finished (Ex. 150; 329 (1/18/2011, p. 267, 270, 276–277, 301)). OSHA has modified the rules so roof anchorages are not required for inspections prior to starting work or after completing work (§ 1910.28(a)(2)(ii)). As a result, most short chimney cleaning and inspection jobs will not require use of anchorages and fall protection. In those situations where work actually needs to be done on a roof, and thus more time will be required on the roof, OSHA has modified the rule to except requirements for anchorages in situations where employers can demonstrate that installing anchorages for personal fall arrest systems as well as using any other conventional fall protection is infeasible or creates a greater hazard (§ 1910.28(b)(1)(ii)). Because the length of chimney sweep jobs varies widely as does the time to install anchors, individual determinations on whether installation of personal fall protection anchorages would make the job more dangerous than not using the required fall protection are required. Where anchorages are infeasible or create a greater hazard, employers must develop and implement a fall protection plan, including implementing other control

measures, to eliminate or reduce fall hazard hazards for workers.

OSHA also differs with the NCSG's statement above with respect to time requirements and expense for installing fall protections. In response to a question from the OSHA panel on the feasibility and potential benefits of anchorage and lifeline systems on roofs, a representative of the Industrial Safety Equipment Association stated in the public hearing:

In the event of existing construction there are permanent roof anchors that can be installed on residential structures and other types of facilities, buildings and so on that can be installed after the construction. And depending upon the type of construction, those can range in cost anywhere from, you know, \$35 to a few hundred dollars. And they have varying degrees of installation, again depending upon the type of structure.

There are also—if it's new construction there are different construction techniques where the anchors can be installed, for instance, on the roof truss before the truss is put up into place so that the anchor's already up there and then you can use first man type systems to anchor your lifeline on the ground before the worker has to climb to do the work at the height.

So there are various types of roof anchor products. And you know, I would—every fall protection equipment manufacturer manufactures a number of different types specifically for the roofing industry (Ex. 329 (1/18/2011), pp. 176–177).

OSHA also notes that where an employer can show that it is not feasible to use guardrails, safety nets, or personal fall protection systems in work on residential roofs (or it creates a greater hazard), the final rule requires the employer to develop and implement a fall protection plan and training meeting the requirements of the construction standard (final rule § 1910.28(b)(1)(ii)).

Charles Lankford of Rios & Lankford Consulting International challenged OSHA's finding in the PEA that fatalities involving falls represent a risk so significant that only a revised standard with a scope covering all of general industry will address the problem:

The relative ranking of falls appears to have more to do with the falling rate of workplace homicides than with an increase in fatal falls, since the rate of fatal falls has remained fairly constant at around 5 and 6 fatal falls per million employees for decades.

While it is true that fatal falls were 14% of all fatalities (2009 BLS data), this was not evenly distributed among the industrial sectors. In the "goods producing" sector, falls were the second (or third) leading cause of death, and were ten times more likely than a homicide to be the cause of death. This is the major category that includes mining, agriculture, construction and manufacturing.

In contrast, in the service sector, falls were the third (or fourth) leading cause of death. In the service sector overall, homicides were twice as likely to be the cause of death as a fall. In some NAIC codes, homicides were 4 times more likely to be the cause of death than a fall. The service sectors where fatal falls were relatively more likely were: (1) Durable goods wholesale; (2) utilities; (3) information; and (4) administrative and waste services.

I've focused on fatal falls data rather than non-fatal falls because the non-fatal data are more subject to variations from record-keeping interpretations, data initiatives, etc.

Never-the-less historical incident rates for non-fatal falls also do not display an increasing fall problem. The all-industries non-fatal fall incidence rate has declined every year since 2003 (the oldest year in the BLS Table I consulted), so the decline in rates is not attributable to the current recession. If we exclude 2008 and 2009 data, manufacturing did not show a change. Yet 2006 and 2007 showed lower injury incidence rates than 2003 and 2004 (Ex. 368).

In response to Mr. Lankford's comment, OSHA notes that, combining data taken from Tables V–1 and V–13, the roughly 5.2 million workers directly exposed to fall hazards had approximately 187,000 lost-workday injuries resulting from falls each year, or 36 injuries per 1,000 workers annually. The hazards faced by these employees are similar, even though they work in a broad range of industries. OSHA believes, as indicated by Mr. Lankford's comment, that the risk of fall-related injuries, combined with the risk of fall-related fatalities, remained at a constant rate in recent years and that the final rule will help prevent a substantial number of them. Accordingly, OSHA concludes that falls constitute a safety threat best addressed by the final rule's revisions to existing subparts D and I.

d. Monetized Benefits, Net Benefits, and Cost Effectiveness

The previous section showed that OSHA judges that complete compliance with the revised standard will result in the prevention of 29 deaths and 5,842 lost-workday injuries each year. Consistent with current federal regulatory methodologies recommended by OMB Circular A–4, discussed below, the Agency assigned a dollar value to these safety benefits.

In estimating the value of preventing a fatality, OSHA followed the approach established by the U.S. Environmental Protection Agency (EPA). EPA's *Guidelines for Preparing Economic Analyses* provides a detailed review of methods used to estimate mortality-risk values, and summarizes the values obtained in the literature (EPA, 2000). Synthesizing the results from 26 relevant studies, EPA arrived at a mean

value for a statistical life (VSL) of \$4.8 million (in 1990 dollars). EPA recommends this central estimate, updated for inflation, for application in regulatory analyses.

Viscusi and Aldy (2003) presented a metaanalysis of studies in the economics literature that used a willingness-to-pay (WTP) methodology to estimate the imputed value of life-saving programs, and arrived at a value of approximately \$7.0 for each avoided fatality. Applying the GDP deflator (U.S. BEA, 2010), this \$7.0-million base number in 2000 dollars yields an estimate of \$8.7 million in 2010 dollars for each fatality avoided.

This VSL estimate is consistent with EPA's estimate, and is also within the range of the substantial majority of such estimates in the literature (\$1 million to \$10 million per statistical life), as discussed in OMB Circular A-4 (OMB, 2003). Applying a VSL of \$8.7 million to the estimated number of prevented fatalities, OSHA estimates that the dollar value of the benefits associated with preventing fatal accidents from compliance with revised subparts D and I will be \$252.3 million annually.

OSHA also reviewed the available research literature regarding the dollar value of preventing an injury. In the paper cited immediately above, Viscusi and Aldy conducted a critical review of 39 studies estimating the value of a statistical injury (Viscusi and Aldy, 2003). In their paper, Viscusi and Aldy reviewed the available WTP literature to

identify a suitable range of estimates; using WTP to value non-fatal injuries is the approach recommended in OMB Circular A-4.

Viscusi and Aldy found that most studies resulted in estimates in the range of \$20,000 to \$70,000 per injury (in 2000 dollars), although several studies resulted in higher estimates. That some studies used an overall injury rate, and others used only injuries resulting in lost workdays, partly explains the variation in these estimates. The injuries prevented by final subparts D and I often involve hospitalization and, therefore, are likely to be more severe than the majority of lost-workday injuries. In addition, injuries resulting from falls involve more pain and suffering, more expensive treatments, and generally longer recovery periods than other lost-workday injuries.¹¹⁷

Thus, it is reasonable to believe that the value of a statistical injury for this rulemaking will be in the upper part of the reported range of estimates. Nevertheless, in the preliminary benefits analysis discussed in the PEA, OSHA used a mid-range estimate—\$50,000—to assess monetized benefits for injuries and, for this FEA, raised that estimate to \$62,000 (2010 dollars) to

¹¹⁷ In 2009, the median number of days away from work was 14 days for falls to a lower level, whereas the median number of days away from work for all events or exposures leading to injury or illness was 8 days (BLS, 2012). For more discussion of this issue, see Part II of this document.

account for a rise in the cost of living since 2000, the base year for the monetized values estimated by Viscusi and Aldy when the authors published their 2003 study. Thus, with an estimated 5,842 injuries a year prevented by the final standards, OSHA determined that the dollar value of prevented injuries through compliance with revised subparts D and I will total \$362.2 million annually.

OSHA estimates that the combined dollar value of prevented fatalities and injuries through compliance with the final revisions to subparts D and I will total \$615 million per year. Comparing gross monetized benefits with costs of compliance (discussed in more detail in section V.F, below), OSHA estimates that the net monetized benefits of the final standard will be \$310 million (\$615 million in benefits—\$305.0 million in compliance costs; all figures rounded). Table V-14 summarizes the compliance costs, benefits, net benefits, and cost effectiveness of the final standards.

There are other benefits of the final standards that OSHA neither quantified nor monetized. First, OSHA did not estimate the number of fall injuries prevented that do not result in lost workdays. Second, OSHA did not estimate improvements in the efficiency of compliance associated with clarifying the existing rule and bringing it into closer correspondence with current voluntary standards.

BILLING CODE 4510-29-P

Table V-14
Net Benefits of the Final Subparts D and I Standards
 (millions of 2010 dollars)

Annualized Costs[a]	
§1910.22 General Requirements	\$33.2
§1910.23 Ladders	\$11.3
§1910.24 Step Bolts and Manhole Steps	\$18.0
§1910.27 Scaffolds and Rope Descent Systems	\$71.6
§1910.28 Duty to Have Fall Protection	\$55.9
§1910.29 Fall Protection Systems Criteria and Practices	\$13.1
§1910.30 Training Requirements	\$74.2
§1910.132 General Requirements	\$12.7
§1910.140 Personal Fall Protection Systems	\$11.0
Rule Familiarization	\$4.1
Total Annual Costs	\$305.0
Annual Benefits	
Number of Injuries Prevented	5,842
Number of Fatalities Prevented	29
Monetized Benefits (assuming \$62,000 per injury and \$8.7 million per fatality prevented)	\$615.0
Injuries not Resulting in Lost Workdays and Improved Compliance Efficiency	Unquantified
Net Benefits (benefits minus costs)	\$310.0

[a] Data may not sum to totals due to rounding. The monetized benefit per fatality avoided is \$8.7 million (in 2010 dollars, after applying the GDP deflator to \$7.0 million in 2000 dollars).

Source: U.S. Department of Labor, OSHA, Directorate of Standards and Guidance, Office of Regulatory Analysis-Safety.

BILLING CODE 4510-29-C

E. Technological Feasibility

OSHA reviewed the substantial evidence collected throughout this rulemaking, including the data and comments submitted to the record in response to the earlier proposed standard published on April 10, 1990, the notice reopening the record published on May 2, 2003, and the recent NPRM (May 24, 2010). Accordingly, OSHA determined that compliance with the final revisions to subparts D, I, and other subparts in 29 CFR part 1910 (general industry), as described in this final rule, is technologically feasible. This subsection presents the details of this conclusion with regard to specific requirements.

1. Technological Feasibility for Final Subpart D (Walking-Working Surfaces) General Requirements (§ 1910.22)

Section 1910.22 of final subpart D revises existing requirements addressing housekeeping, safe aisles and passageways, covers and guardrails, and floor-loading protection, and introduces new requirements associated with broad areas of safety on walking-working surfaces. Final paragraphs (a), (b), (c), and (d) of this section address, respectively, surface conditions, application of loads, access and egress, and inspection, maintenance, and repair. OSHA received no testimony in the record suggesting that there would be feasibility concerns with final § 1910.22.

Final paragraph (a) requires that employers keep all walking-working surfaces in a clean, dry, orderly, and sanitary condition, and free of hazards such as sharp or protruding objects, loose boards, corrosion, leaks, and spills. Data in OSHA's inspection file analyzed by ERG (ERG, 2007) indicate a high level of compliance with similar requirements in existing subpart D, suggesting that there have been few, if any, technical challenges to employers; therefore, this provision is technologically feasible.

Final § 1910.22(b) requires that employers ensure that each walking-working surface can support the maximum intended load for that surface. This language restates and simplifies the existing regulatory text, and should not present any technological feasibility difficulties. The next provision, final § 1910.22(c), requires that employers provide employees with, and ensure that they use, a safe means of access and egress to and from walking-working surfaces. Although new, this requirement, in OSHA's judgment, will not impose any

duties on employers beyond the limits of feasibility.

Paragraph (d) of final § 1910.22 requires employers to regularly inspect and maintain, as necessary, all walking and working surfaces in a safe condition. Employers also must correct and repair all hazardous conditions on walking-working surfaces before employees use them, and guard the surfaces until completing repairs to prevent employee use. A qualified employee must perform or supervise any correction or repair that involves the structural integrity of a walking-working surface. Employers can accomplish the inspection, maintenance, repair, and guarding of surfaces with technologically feasible and currently available methods.

Ladders (§ 1910.23)

Final § 1910.23 covers ladders. Accordingly, final § 1910.23(a) specifies that the section applies to all ladders except for ladders used only for firefighting, rescue operations, tactical law enforcement operations, or training for these operations, and ladders designed into, or are an integral part of, a machine or piece of equipment. In addition, final § 1910.23(b) provides general requirements for all ladders; final paragraph (c) addresses portable ladders; final paragraph (d) presents standards for fixed ladders; and final paragraph (e) addresses mobile ladder stands and mobile ladder stand platforms. OSHA based the requirements in this section partly on current American National Standards Institute (ANSI) standards, A14 series. The ANSI standards provide guidelines for industry, and are generally compatible with current industry practices and technology. Since manufacturers make and test virtually all manufactured ladders to meet these ANSI standards, OSHA believes there will be few problems regarding technological feasibility.

Most of the requirements for ladders in final subpart D do not represent any change from existing OSHA requirements. For both existing and new requirements, current and readily available technology is capable of meeting or exceeding the design and strength criteria specified for ladders. The final language is clearer and more concise than the existing regulatory text. Moreover, OSHA introduced greater compliance flexibility into the final standard, such as in the case of the range provided in the spacing requirements for rungs, cleats, and steps (see final § 1910.23(b)).

Comments submitted to the docket in response to the 1990 proposed rule

generally confirmed OSHA's preliminary conclusion that compliance with the proposed requirements for ladders would be technologically feasible. Although several commenters addressed the appropriateness or the costs associated with the proposed ladder requirements, they did not question the technological feasibility of the requirements. Similarly, during the reopening of the record following publication of the 2010 NPRM, commenters raised concerns about the potential costs for protecting workers on ladders in particular circumstances (see, for example, Exs. 121; 301; 342) or the rationale for excluding ladders from the duty to provide fall protection for heights above four feet (Ex. 185). However, there was no evidence presented that would suggest that the final standard for ladders is technologically infeasible.

OSHA grouped training in the proper care, use, and inspection of ladders with other training requirements under final § 1910.30. Compliance with these training requirements does not require any additional or new technology.

Step Bolts and Manhole Steps (§ 1910.24)

Final subpart D provisions for step bolts and manhole steps address basic criteria for the safe design, construction, and use of these components. For example, final § 1910.24(a)(3) specifies uniform spacing of step bolts between 12 inches (30 cm) and 18 inches (46 cm) measured center to center, while § 1910.24(b)(2)(iv) requires uniform spacing of manhole steps not more than 16 inches (41 cm) apart. Although these requirements will be new to subpart D, OSHA based the engineering criteria on consensus standards established by the American Society for Testing and Materials (ASTM), which have wide acceptance throughout industry. Therefore, OSHA believes that existing technology is capable of meeting these performance criteria and that this technology is feasible to apply.

Stairways (§ 1910.25)

Section 1910.25 in the final standard describes OSHA safety specifications for stairs, and covers all types of stairs except stairs serving floating roof tanks; stairs on scaffolds; stairs designed into machines or pieces of equipment; and stairs on self-propelled motorized equipment. Requirements in this section address the obligations to install handrails, stair-rail systems, and guardrail systems, as necessary. Other requirements in this section describe design specifications such as the appropriate load capacities that stairs

must be able to support, minimum vertical clearances for different types of stairs, the height of risers, the depth of treads, and the proper angle of stairs. These requirements are not substantially different from the requirements of the existing standard; OSHA drew the requirements from NFPA and ANSI consensus codes, indicating that industry already adopted the requirements as a feasible industry practice using existing technology.

Dockboards (§ 1910.26)

Section 1910.26 provides for the safe movement of personnel and equipment on dockboards (defined in the final standard to include bridge plates and dock plates), and relocates, updates, and clarifies requirements for dockboards located in existing § 1910.30, Other working surfaces. The design, construction, and maintenance of these surfaces must be such as to support their maximum intended load and prevent transfer vehicles from running off the edge. According to final § 1910.26(c), employers must secure portable dockboards with anchors or other means, when feasible, to prevent displacement while in use. Other requirements in this section prevent the sudden displacement of vehicles on dockboards that are in use, and require handholds or other means for safe handling. Compliance with the final requirements for dockboards does not necessitate the use of any new technologies, materials, or production methods; thus, this section is technologically feasible.

Scaffolds and Rope Descent Systems (§ 1910.27)

Section 1910.27 introduces to subpart D the existing requirements for scaffolds in the construction standards. Thus, for final subpart D, OSHA directly references subpart L in 29 CFR part 1926. In addition, new requirements for rope descent systems will include inspection prior to each workshift; proper rigging; a separate personal fall arrest system; minimum strength criteria for lines used to handle loads; establishment of rescue procedures; effective padding for ropes; and stabilization for descents greater than 130 feet. In addition, final § 1910.27(b)(2) prohibits the use of rope descent systems for heights greater than 300 feet (91 m) above grade unless the employer can demonstrate that it is not feasible to access such heights by any other means or those other means pose a greater hazard than using RDS. Although new to subpart D, industry adopted these and other specifications for the safe use of scaffolds many years

ago owing to the publication of ANSI I-14.1-2001, Window Cleaning Safety (Ex. 14), and a March 12, 1991, OSHA memorandum to Regional Administrators addressing the ANSI standard and the provisions listed above (Ex. OSHA-S029-2006-0662-0019). Therefore, OSHA judges the requirements in this new section on scaffolds to be technologically feasible.

Duty To Have Fall Protection and Falling-Object Protection (§ 1910.28)

Section 1910.28 restates, clarifies, and adds flexibility and consistency to existing OSHA requirements for providing fall protection to employees. In addition to general requirements for the strength and structural integrity of walking-working surfaces (with reference to § 1910.29, Fall and falling-object protection systems criteria and practices), this section of the final rule also includes detailed specifications on the following surfaces for which employers have a duty to provide fall protection:

- Unprotected sides and edges;
- Hoist areas;
- Holes;
- Dockboards;
- Runways and similar walkways;
- Dangerous equipment;
- Wall openings;
- Repair pits, service pits, and assembly pits less than 10 feet in depth;
 - Fixed ladders (that extend more than 24 feet (7.3 m) above a lower level);
- Outdoor advertising (billboards);
- Stairways;
- Scaffolds and rope descent systems;
- Work on low-slope roofs;
- Slaughtering facility platforms; and
- Walking-working surfaces not otherwise addressed.

Hazards on walking-working surfaces can include accidental displacement of materials and equipment. To prevent objects from falling to lower levels and to protect employees from the hazards of falling objects, final § 1910.28(c) requires head protection and screens, toeboards, canopy structures, barricades, or other measures.

The final subpart D standards reaffirm the existing Agency interpretation and enforcement practice that fall protection is generally necessary for fall hazards associated with unprotected sides or edges of any surface presenting a fall hazard of four feet or more. In this regard, the obligation of employers to provide fall protection remains substantially unchanged from existing requirements in final subpart D.

Whereas the existing requirements specify that employers must protect employees by installing standard guardrail systems or equivalent systems,

the final standard more clearly allows employers to provide fall protection through any of several methods, including guardrails, personal fall arrest systems, and safety nets. OSHA recognizes that some work surfaces may present difficult challenges for applying fall protection. One participant in the 1990 NPRM (Ex. OSHA-S041-2006-0666-0194) pointed out that maintenance work may require that employees be on equipment such as compressors, turbines, or pipe racks at elevations in the range of 4 to 10 feet above lower surfaces, and that guardrails, platforms, ladders, or tying off would not always be possible in such situations. In the current rulemaking for walking-working surfaces, the Sheet Metal and Air Conditioning Contractors National Association (SMACNA) (Ex. 165) appeared to express a similar concern with respect to the duty to provide fall protection in a manufacturing plant. OSHA notes that its enforcement procedures allow special consideration in unique circumstances when compliance with a particular standard may not be feasible or appropriate.¹¹⁸

In general, employers should be able to address and eliminate employee exposures to potential slip, trip, and fall hazards by planning and designing adequate facilities and work procedures. Based on widespread industry practice, OSHA concludes that the fall protection requirements specified by this section of the final standards are technologically feasible.

Fall Protection Systems and Falling-Object Protection—Criteria and Practices (§ 1910.29)

In § 1910.29, OSHA specifies or provides references for revised criteria for fall protection systems such as guardrail systems; handrails; stair rail systems; cages, wells, and platforms used with fixed ladders; toeboards; designated areas; travel restraint systems; safety net systems; grab handles; and fall protection for the outdoor advertising industry. Final § 1910.140, discussed at length below, provides criteria for personal fall protection systems that OSHA is adding to existing subpart I through this rulemaking.

With regard to guardrail systems (§ 1910.29(b)), the final subpart D standards do not substantially modify existing requirements involving height, strength, or other criteria. In some circumstances on low slope roofs for

¹¹⁸ See OSHA's Field Operation Manual: http://www.osha.gov/OshDoc/Directive_pdf/CPL_02-00-150.pdf.

which the existing standard requires guardrails (or equivalent protection), the final standard allows employers to use designated areas.

Rather than explicitly requiring midrails in guardrail systems as in the existing subpart D standards, the final subpart D standards use performance-oriented criteria that allow midrails, screens, mesh, intermediate members, solid panels, or equivalent intermediate structural members. Compliance with the existing standards would generally also meet the requirements of the final standards. Furthermore, the final standard allows the employer to choose any of a wide variety of currently used and readily available guardrail system materials and designs to meet the performance-oriented criteria. Based on these considerations, the final subpart D requirements for guardrail systems are technologically feasible.

Final § 1910.29(c) references the construction standards to specify criteria for safety net systems. The criteria for safety nets established through this final rulemaking include requirements for drop tests and inspections for each safety net installation. Other criteria for safety nets established in final subpart D involve design and strength standards. Employers can achieve all of these criteria by using existing and commonly available safety net systems. The final requirements for installing safety net systems reflect basic safety considerations already adopted by manufacturers of equipment and by employers. Readily available and currently used technology is capable of meeting these requirements.

The final standard introduces the option of designated areas (see final § 1910.29(d)) as a means of fall protection available to employers, in addition to other acceptable fall protection measures in certain circumstances on low slope roofs. The technology necessary to implement this option consists of basic materials such as rope, wire, or chain, and supporting stanchions. Employers can achieve the strength, height, and visibility criteria specified in the final standard for designated areas with currently available materials and technology.

Requirements for covers for holes in floors, roofs, and other walking-working surfaces in the final standard (see final § 1910.29(e)) simplify and consolidate the proposed requirements for covers and now consist of two new provisions requiring that the cover: (1) Is capable of supporting without failure, at least twice the maximum intended load that may be imposed on the cover at any one time; and (2) Is secured to prevent

accidental displacement. The performance-oriented criteria applicable to covers allow for the application of a wide variety of technological solutions.

Requirements in final subpart D for handrail and stair rail systems (§ 1910.29(f)) specify criteria for height, strength, finger clearance, and type of surface, among others. Employers currently meet these criteria with existing technology, and a wide variety of different materials and designs are available to comply with the requirements.

New requirements in final paragraph (g) of this section specify that landing platforms, as well as all platforms used with fixed ladders and cages and wells, provide a horizontal surface that meets specified dimensions are feasible considering the availability of appropriate materials and engineering expertise. Final § 1910.29(g) also sets criteria for ladder cages and wells, if used on fixed ladders. OSHA notes that the Agency is phasing out the use of cages and wells as a means of fall protection on fixed ladders. See full discussion in summary and explanation of § 1910.28(b)(9).

Final paragraph (h) includes requirements for qualifying employees to climb ladders on outdoor advertising that expire two years after publication of the final standard (see § 1910.28(b)(10)). After this two-year period, employers in outdoor advertising must provide one or more of the fall protection systems specified in § 1910.28 for employees who climb fixed ladders. Although new to subpart D, the training and other administrative controls that characterize the development and protection of those working without fall protection have been around for many years. Furthermore, evidence in the record indicates that some employers in outdoor advertising are now providing conventional fall protection for ladders (Ex. 369). Therefore, OSHA concludes that there will be few, if any, technological hurdles for industry to implement the provisions for qualified climbers before and after the two-year expiration date.

Final paragraph (i) establishes criteria and practice requirements for ladder safety systems permanently attached to fixed ladders or immediately adjacent to such ladders. A ladder safety system is a conventional fall protection system designed to eliminate or reduce the possibility of falling from a fixed ladder (see definition of “ladder safety system” in final § 1910.21(b)). According to this definition, it usually consists of the following:

- A carrier, which is a rigid or flexible track attached to or adjacent to the fixed ladder;
- A safety sleeve, which is moving component that travels on the carrier;
- A lanyard;
- Connectors; and
- A body harness.

Although the existing rule at § 1910.21(e)(13) addresses “ladder safety devices,” which serve the same purpose as ladder safety systems, the existing rule does not specify criteria or practice requirements for those devices. As a result, OSHA drew many of the proposed ladder safety system criteria and practice requirements from the construction ladder standard at § 1926.1053(a)(22) and (23). The construction standard allows the use of body harnesses or body belts with ladder safety systems. OSHA also drew ladder safety system criteria and practice from ANSI/ASC A14.3–2008. The Agency notes the national consensus standard does not include the use of body belts with ladder safety systems.

As noted above, the ladder safety system criteria and practice requirements in the final standard have been published in an OSHA construction standard and in a national consensus standard, and therefore any technological feasibility concerns for the range of structures encountered in general industry would very likely have been addressed in the proceedings that led to those publications. Therefore, OSHA concludes that the final requirements for ladder safety systems are technologically feasible.

Final paragraph (j), like the proposed rule, requires that body belts, body harnesses, and other components of personal fall arrest systems, work-positioning systems, and travel restraint systems, meet the applicable requirements in final § 1910.140. Employers currently meet these criteria with existing technology, and a wide variety of different materials and designs are available to comply with the requirements.

Final § 1910.29(k) clearly specifies criteria for systems that provide falling-object protection. OSHA redrafted the provisions in the existing standard addressing toeboards using specification language found in the OSHA construction standard (§ 1926.502(j)(3)) and with national consensus standards (ANSI/ASSE A10.18–2012 (Section 5.7), and ANSI/ASSE A1264.1–2007 (Section 4.1.5) while other requirements for guardrail systems and canopies specified in the design criteria are within current engineering norms. Therefore, OSHA concludes that the

falling-object protection provisions are technologically feasible.

Lastly, final paragraph (l) contains design and strength criteria for grab handles. For the most part, these requirements are consistent with the requirements for grab handles in existing subpart D and are, therefore, technologically feasible.

Training Requirements (§ 1910.30)

Section 1910.30 introduces requirements specifying that employees receive training from a qualified person, and that the training, which applies to personal fall protection equipment, prepare employees to recognize fall hazards in the work area, in the procedures to follow to minimize these hazards, and in the installation, inspection, operation, maintenance, disassembly, and correct use of personal fall protection equipment. Employers also must train workers in the proper care, inspection, storage, and use of equipment subpart D covers before workers use that equipment, such as dockboards, RDS, and designated areas. Employers must retrain employees when changes occur in the workplace or in the types of fall protection systems or equipment used that renders the previous training obsolete or inadequate, or employees exhibit an absence of understanding or skill needed to use the equipment or perform the job safely; employers also must train employees in a manner the employees understand. Because of extensive evidence in the record that the training required under the final standard has widespread acceptance throughout industry (Exs. 53; 73; 96; 127; 172; 189; 205; 216; 222; 226; 329 (1/18/2011), pgs. 82, 117, 186, 258; 329 (1/19/2011), pgs. 22, 24; 329 (1/20/2011), pgs. 182, 287; 329 (1/21/2011), pgs. 9, 92, 200, 206; 364), such training will not present technological feasibility concerns.

2. Technological Feasibility for Final Subpart I (Personal Protective Equipment)

General Requirements (§ 1910.132)

Revised § 1910.132(g) of subpart I in this final rulemaking requires that employers conduct hazard assessments and training in accordance with the requirements in § 1910.132(d) and (f) in workplaces when employers provide personal fall protection equipment to employees. Survey data indicate that a significant percentage of employers currently assess the occupational fall hazards encountered by their employees, and that a similarly large percentage of employers train their employees in the proper use of personal

fall protection equipment (OSHA, 1994). These hazard assessment and training requirements, therefore, will not present technological feasibility concerns.

Personal Fall Protection Systems (§ 1910.140)

The final subpart D standards include provisions for personal fall protection systems, including components such as harnesses, connectors, lifelines, lanyards, anchorages, and travel restraint lines. Section 1910.140 of subpart I specifies the criteria that these components must meet when employees use them.

The revisions to the walking-working surfaces and fall protection systems described in the final rule include revisions to several subparts in 29 CFR part 1910 other than subparts D and I. For purposes of this analysis, the determinations of technological feasibility described in this FEA include the revisions of these other subparts.

The requirements applicable to personal fall protection systems specified by this final rulemaking codify basic safety criteria for these systems. These criteria reflect common industry safety practices, and currently and readily available equipment meets these criteria. The final standards generally do not require changes in current technology or practices for employers who use standard safety equipment and follow standard safety procedures. The current and ready availability of personal fall protection systems, including personal fall arrest systems, positioning systems, and travel restraint systems, and the application of these technologies in diverse industrial activities and circumstances, demonstrate the technological feasibility of these requirements in the final standard.

3. Summary of Technological Feasibility

In conclusion, OSHA determined that compliance with the final revisions to subparts D, I, and other affected subparts of 29 CFR part 1910 is technologically feasible. Thus, there is no technological hindrance to the significant improvement of employee safety on walking and working surfaces resulting from implementation of this final rule.

F. Costs of Compliance

1. Introduction

This subsection presents OSHA's final analysis of the compliance costs associated with the final standard for walking-working surfaces and fall protection in general industry. Following discussion on the public

comments addressing OSHA's preliminary estimate of compliance costs and OSHA's response to those comments, the cost analysis proceeds into a discussion of the assumptions used in the analysis. OSHA based its final analysis of compliance costs largely on the cost analysis conducted by OSHA's contractor, Eastern Research Group (ERG, 2007), and the Preliminary Economic Analysis. The presentation below focuses on what constitutes the regulatory baseline (*i.e.*, current conditions) from which OSHA measured the costs, impacts, and benefits of the final rule. The Agency also discusses the effect of consensus standards and the compliance rates for the existing rule on the cost analysis (*i.e.*, when codification of existing consensus standards results in little to no incremental costs for the final rule).

Following the discussion of baseline assumptions, the next subsection reviews the final rule on a paragraph-by-paragraph basis for those paragraphs that potentially could result in costs to industry. The final subsection examines one-time costs to bring employers into compliance with the rule, as well as the annual costs for training new employees and retraining existing employees. OSHA presents the cost estimates by affected industry, and by applicable provision. The final subsection concludes with a discussion and tables that summarize the costs for each section of the standard, and aggregates them to estimate total costs.

2. Public Comments on the Preliminary Cost Analysis

OSHA requested comment on the assumptions, unit costs, and analytical methods applied in the preliminary cost analysis for proposed subparts D and I. The discussion below summarizes the public comments addressing OSHA's preliminary cost analysis and OSHA's response to those comments.

The Sheet Metal and Air Conditioning Contractors National Association (SMACNA) was critical of OSHA's estimate of compliance costs, stating:

A review of the anticipated costs indicates that OSHA has under-estimated the actual costs to employers to comply with the requirements of these rules. SMACNA encourages OSHA to conduct further outreach to employers to find the true costs associated with the revisions to company operations, purchasing equipment and conducting training that these proposed standards would require. With over 5 million small businesses affected by these requirements (OSHA's data), it is fair and prudent upon OSHA to outreach to these companies by convening a Small Business Regulatory Enforcement Fairness Act panel. (Ex.165, p. 5.)

With respect to the convening of a Small Business Regulatory Enforcement Fairness Act (SBREFA) panel, OSHA in the NPRM certified that the proposed standard would not have a significant impact on a substantial number of small firms, which satisfied the statutory requirements at the time OSHA published the NPRM. Other stakeholders who also requested that OSHA convene a SBREFA panel include the National Federation of Independent Businesses (Ex. 173) and the U.S. Chamber of Commerce (Ex. 202). With respect to SMACNA's assertion that OSHA underestimated compliance costs, SMACNA did not provide any further details to support its statement, and, therefore, OSHA has no basis to evaluate the criticism.

ORC HSE Networks, a division of Mercer LLC, expressed concerns about the proposed requirement, found in § 1910.29(b)(1), that the top edge of guardrail systems be 42 inches (107 cm), plus or minus 3 inches (8 cm), above the walking-working surface. Mercer's comment reads as follows:

In a footnote on page 28894 of the May 24 notice of proposal, OSHA stated that it decided not to include existing guardrails having top edges as low as 36 inches from the working surface in any of the "grandfathering" provisions of this rule despite such a provision having been included in the previous proposals and acknowledged as a "de minimis" violation of the existing standard in various OSHA letters of interpretation. While OSHA states that it does not consider 36 inches to be "equally safe" to the "42 inches nominal" requirement in the existing standard or the 42 inches plus or minus three inches in the proposed rules, OSHA provided no rationale or support for this proposed decision.

OSHA's economic and benefits analyses should estimate the number of injuries that would be prevented if existing guardrails that have heights between 36 and 39 inches must be replaced with those having at least a 39-inch height. In addition, OSHA should determine the costs that will be associated with replacing guardrails with top edge heights between 36 and 39 inches and include them in the regulatory and economic feasibility analyses for these rules. Clearly, if people have been writing to OSHA to ask about guardrails that are less than the "42 inches nominal" in the existing rule, there are likely to be significant numbers of workplaces that have these non-standard guardrails in place. OSHA should either quantify the benefits and costs of this rule change or grandfather those guardrail installations that occurred prior to the effective date of the new rules. Only new or remodeled facilities should be required to follow the new requirement for top edge height of guardrails. (Ex. 170, p. 6.)

As noted in the NPRM (75 FR 28894), the proposed provision for the height of guardrail systems was essentially the

same as the existing requirement in § 1910.23(e)(1). Despite proposed grandfathering of guardrails with heights as low as 36 inches (above the working surface) under the two previous proposals (1973 and 1990), OSHA believes that in the 40 or so years since it issued the existing standard, a large percentage of the walking-working surfaces protected by guardrails are in compliance with the 39-inch minimum-height standard. In the absence of data in the record on the range of heights of guardrails throughout industry, OSHA believes that the percentage of guardrail systems not meeting the minimum height requirement is low. Therefore, if OSHA's belief is correct, the additional cost burden and economic impacts for employers not in compliance with the final height requirement would be relatively insubstantial and, therefore, would not present economic feasibility concerns.

Corporate Cleaning Services, a leading window washing company in Chicago, urged OSHA to consider the economic ramifications of limiting the permitted distance when using rope descent systems (RDS) to 300 feet (Ex. 126). In written testimony, Corporate Cleaning Services stated that the use of suspended scaffolds could add up to 30 percent to the time required to complete a job compared with RDS. By comparison, in a post-hearing comment, Valcourt Building Services estimated that the cost increase would range from 10 to 20 percent if it had to use a permanent scaffold installation as an alternative to RDS (Ex. 358). In response to these comments, OSHA in this FEA estimated the costs and economic impact of the 300-foot distance limitation for RDS specified in the final rule. OSHA discusses the revised cost estimate below under § 1910.27, Scaffolds and rope descent systems.

Charles Lankford of Rios & Lankford Consulting International argued that OSHA's requirement, under the paragraph for general conditions, that walking-working surfaces be designed, constructed, and maintained free of recognized hazards would impose legal responsibilities, and hence, legal costs, on employers that OSHA neglected in the PEA. Mr. Lankford stated:

My review of the risk-benefit analysis in the proposed rule did not find that OSHA considered the costs of defending from citations being issued after the collapse of a surface the employer did not have tested or evaluated by an engineer after a plant purchase, that might have resulted in a fatality. It is reasonable to expect that litigation costs arising from new regulations should be included in an estimate of costs, when conducting a risk-benefit analysis.

OSHA does not seem to have considered all the ramifications, or having considered them, opted to leave them in a grey area so as to more broadly enforce these provisions to the detriment of employers. (Ex. 368.)

OSHA agrees with Mr. Lankford that the failure of employers to exercise due diligence in ensuring the safety of workers on surfaces could result in torts and other legal expenses. However, the probability of legal liability will diminish to the extent that employers expend the resources necessary to achieve compliance with more stringent fall protections.

In a comment to the record and testimony at the public hearing, the National Chimney Sweep Guild (NCSG) expressed concerns about the costs and economic feasibility of compliance with the proposed standard for the businesses performing chimney-cleaning services and other related work on residential roofs (Exs. 150; 296; 329 (1/18/2011), p. 342; 365). The following post-hearing comment summarizes the views voiced by NCSG throughout the rulemaking:

If adopted and enforced as proposed, the provisions of the Proposed Rule that address the structural integrity and condition of walking-working surfaces, the use of ladders, and the selection and use of fall protection would: (1) substantially affect the manner in which chimney sweeps perform their work; (2) expose sweeps (and/or the roofing trade) to greater hazards than current industry practices; (3) threaten the continuing economic viability of the chimney sweeps industry; and (4) threaten the availability of chimney inspection, sweeping and repair services at affordable prices, which would be expected to result in less chimney inspections/sweeping/repairs and a significant increase in residential fires and/or an increase in falls by homeowners or other self-employed individuals who would perform these tasks. (Ex. 365, pp. 2–3.)

Below under the heading "Cost estimates" and in section H, Regulatory Flexibility Screening Analysis, OSHA addresses NCSG's concerns.

3. Cost Assumptions

a. Baseline for Estimating Costs

The Office of Management and Budget's guidance on regulatory analysis (OMB, 2003) discusses how to develop a baseline against which to measure the costs and benefits of a rule. The baseline should be the best assessment of conditions absent the proposed standard, and is frequently assumed to resemble the present practice broadly observed among affected employers (although the more technically correct approach from a benefit cost analysis viewpoint, where feasible, is to project the hypothetical future state of the world in the absence

of the rule). The baseline for this final cost analysis, then, includes rates of compliance with existing subparts D and I, as well as with applicable national consensus standards. For a discussion on the theoretical underpinnings for the use of consensus

standards as a baseline in OSHA's cost analysis, see ERG, 2007.

OSHA analyzed Agency inspections for fiscal year 2005 that resulted in a citation (OSHA, 2006a); see Table V-15. The first column in the table presents cases for which OSHA issued a citation for any reason, and the other columns

in the table indicate cases of non-compliance with a section of 29 CFR part 1910, subpart D. Table V-15 may overstate the noncompliance rate because it does not include inspections for which no citations were issued.

BILLING CODE 4510-29-P

Table V-15
Compliance with Existing 29 CFR 1910 Requirements

Sector	Inspections With Citations	Inspections With Subpart D Citations													
		§1910.23		§1910.24		§1910.25		§1910.26		§1910.27		§1910.28		§1910.29	
	Total	Floor Guarding		Fixed Industrial Stairs		Portable Wood Ladders		Portable Metal Ladders		Fixed Ladders		Scaffolding		Manually Propelled Aerial Platforms	
Manufacturing	6,773	732	10.8%	168	2.5%	18	0.3%	23	0.3%	60	0.9%	16	0.2%	19	0.3%
Transportation and Utilities	1,301	115	8.8%	15	1.2%	0	0.0%	7	0.5%	11	0.8%	3	0.2%	5	0.4%
Retail trade	680	58	8.5%	14	2.1%	2	0.3%	6	0.9%	3	0.4%	1	0.1%	2	0.3%
Wholesale trade	670	91	13.6%	18	2.7%	1	0.1%	7	1.0%	8	1.2%	4	0.6%	0	0.0%
Finance, Insurance, and Real Estate	107	3	2.8%	0	0.0%	0	0.0%	2	1.9%	0	0.0%	1	0.9%	0	0.0%
Services	1,938	106	5.5%	19	1.0%	4	0.2%	5	0.3%	10	0.5%	15	0.8%	3	0.2%
All sectors	11,469	1,105	9.6%	234	2.0%	25	0.2%	50	0.4%	92	0.8%	40	0.3%	29	0.3%

Source: ERG, 2007, based on analysis of OSHA's Integrated Management Information System inspection database (OSHA, 2006a).

Based on the analysis presented in Table V-15, OSHA determined that upper-bound non-compliance rates for floor-guarding requirements in current § 1910.23 vary by industry. For example, the Finance, Insurance, and

Real Estate category has the lowest non-compliance rate (2.8 percent), while Wholesale Trade has the highest non-compliance rate (13.6 percent). For the requirements for fixed industrial stairs, the non-compliance rates are quite low, ranging from 0 percent (Finance, Insurance, and Real Estate) to 2.7 percent (Wholesale Trade). For the remaining sections (portable wood ladders, portable metal ladders, fixed ladders, scaffolding, and manually propelled mobile ladder stands and scaffolds), non-compliance rates do not exceed 1.9 percent.

Thus, for §§ 1910.25 through 1910.29, the assumption of 100 percent industry compliance with the existing requirements may be reasonable.¹¹⁹ That is, employers will incur costs only when the final requirements exceed the existing requirements. OSHA requested comments on rates and levels of non-compliance with respect to existing requirements in subpart D, but received no comments; therefore, OSHA applied the preliminary compliance estimates for existing subpart D in this FEA.

If meeting an existing requirement also would meet the final requirement, OSHA did not assign costs to the provision. For example, the existing language for § 1910.27(b)(1)(iii) states that the clear length of a rung or cleat in a fixed ladder shall be a minimum of 16 inches. Final § 1910.23(b)(4)(iii) states that rungs and steps on rolling ladders used in telecommunication centers must have a minimum clear step or rung width of 8 inches (20 cm). A

¹¹⁹ OSHA implicitly considered the costs for all industrial sectors to meet the existing standards when it published those standards.

rolling ladder in telecommunications that meets existing requirements (16 inches) would also meet the new requirements (a minimum of 8 inches); hence, OSHA assigned no costs to the final requirement. Later in this cost analysis, a detailed provision-by-provision examination of potential costs will provide further concrete examples of OSHA's application of estimates of current industry compliance and practices.

b. Compliance With National Consensus Standards

In some instances, the final rule's provisions reflect existing national consensus standards, and OSHA used information on adherence to those standards to estimate compliance rates with the concerned provisions. Due to general adherence to national consensus standards, for purposes of this analysis, national consensus standards serve as the "baseline" against which OSHA measured the incremental costs and benefits of the final standard. If the final standard requires a level of safety equivalent to that in an existing consensus standard, then there is no difference between the final standard and the baseline except that the final standard would be mandatory rather than voluntary. Thus, the costs are those costs associated with the change from a voluntary standard to a mandatory standard. In such cases, OSHA assumes employers in compliance with the voluntary consensus standard incur no additional costs to meet the final rule's requirements. Only that part of the employer population that currently does not comply with the voluntary

standards would incur these costs. If, however, the final standard is more stringent than the consensus standard, OSHA assumed that employers who are not already following practices that would constitute compliance with the final standard would incur compliance costs solely attributable to the final OSHA standard.

ERG developed a logic-flow diagram outlining the process for identifying costs associated with new regulatory language (see ERG, 2007, Figure 3-2). The starting point is a side-by-side, provision-by-provision comparison of the existing and final regulatory language. In many cases, the language changed to enhance comprehension of the regulation without changing the scope of activities covered or its requirements. In some cases, the final language gives the employer alternative methods of compliance that provide protection for employees equivalent to the original standard, thereby resulting in *no* costs to the employer.

If there is a change from the existing to the final standard, the second decision point is to determine whether the final standard is equivalent to an existing consensus standard. If it is, then there would be no costs associated with the final standard for those employers already meeting the consensus standard, but there would be costs for those employers currently not meeting the consensus standard.

Table V-16 lists the national consensus standards used in subparts D and I and the associated section of the final rule for subparts D and I that refer to each of these consensus standards.

Table V-16
Final Subpart D Requirements and Associated National Consensus Standards

Subpart D Section	National Consensus Standard
§1910.22 General Requirements	ANSI/ASSE A1264.2-2012, Standard for the Provision of Slip Resistance on Walking/Working Surfaces.
§1910.23 Ladders	<p>ANSI A14.1-2007, American National Standard for Ladders - Wood Safety Requirements.</p> <p>ANSI A14.2-2007, American National Standard for Ladders - Portable Metal - Safety Requirements.</p> <p>ANSI A14.3-2008, American National Standard for Ladders - Fixed - Safety Requirements.</p> <p>ANSI A14.5-2007, American National Standard for Ladders - Portable Reinforced Plastic - Safety Requirements.</p> <p>ANSI A14.7-2011, Safety Requirements for Mobile Ladder Stands and Mobile Ladder Stand Platforms.</p>

Table V-16
Final Subpart D Requirements and National Consensus Standards (continued)

Subpart D Section	National Consensus Standard
§1910.24 Step Bolts and Manhole Steps	<p>ASTM C478-13, Standard Specification for Precast Reinforced Concrete Manhole Sections.</p> <p>ASTM A394-08, American Society for Testing and Materials Specification for Steel Transmission Tower Bolts, Zinc-Coated and Bare.</p> <p>ASTM C497-13, American Society for Testing and Materials Test Methods for Concrete Pipe, Manhole Sections, or Tile.</p> <p>IEEE¹²⁰ 1307-2004, IEEE Standard for Fall Protection for Utility Work.</p> <p>TIA¹²¹-222-G-2009, Structural Standard for Antenna Supporting Structures and Antennas.</p>
§1910.25 Stairways	<p>ANSI/ASSE A1264.1-2007, Safety Requirements for Workplace Walking/Working Surfaces and Their Access; Workplace Floor, Wall and Roof Openings; Stairs and Guardrails Systems.</p> <p>NFPA 101-2012, National Fire Protection Association Life Safety Code.</p> <p>ICC IBC-2012, International Code Council International Building Code.</p>
§1910.26 Dockboards	<p>ITSDF B56.1-2012, Industrial Truck Standards Development Foundation, Trucks, Low and High Lift, Safety Standard.</p> <p>ANSI/MH30.1-2007, Specification for Dock Leveling Devices.</p> <p>ANSI/MH30.2-2005, Portable Dock Loading Devices: Safety, Performance, and Testing.</p> <p>ASME/ANSI MH14.1-1987, Loading Dock Levelers and Dockboards</p>

¹²⁰ IEEE: Institute of Electrical and Electronics Engineers.

¹²¹ TIA: Telecommunications Industry Association.

Table V-16
Final Subpart D Requirements and National Consensus Standards (continued)

Subpart D Section	National Consensus Standard
<p>§1910.27 Scaffolds and Rope Descent Systems</p>	<p>ANSI/IWCA I-14.1-2001, Window Cleaning Safety.</p> <p>ANSI/ASCE 7-2010, American National Standard for Minimum Design Loads for Buildings and Other Structures.</p> <p>ANSI/ASSE Z359.4-2012, Safety Requirements for Assisted-Rescue and Self-Rescue Systems, Subsystems and Components.</p>
<p>§1910.28 Duty to Have Fall Protection</p>	<p>ANSI A10.11-2010, Safety Requirements for Personnel and Debris Nets.</p>
<p>§1910.29 Fall Protection Systems Criteria and Practices</p> <p>§1910.30 Training Requirements</p>	<p>ANSI A14.3-2008, American National Standard for Ladders - Fixed - Safety Requirements.</p> <p>ANSI A1264.1-2007, Safety Requirements for Workplace Walking/Working Surfaces and Their Access; Workplace, Floor, Wall and Floor Openings; Stairs and Guardrail Systems.</p> <p>ANSI/IWCA I-14.1-2001, Window Cleaning Safety.</p>

Table V-16
Final Subpart D Requirements and National Consensus Standards (continued)

Subpart D Section	National Consensus Standard
§1910.140 Personal fall protection systems	ANSI Z359.0-2012, Definitions and Nomenclature Used for Fall Protection and Fall Arrest.
	ANSI Z359.1-2007, Safety Requirements for Personal Fall Arrest Systems, Subsystems and Components.
	ANSI Z359.2-2007, Minimum Requirements for a Comprehensive Managed Fall Protection Program.
	ANSI Z359.3-2007, Safety Requirements for Positioning and Travel Restraint Systems.
	ANSI Z359.4-2013, Safety Requirements for Assisted-Rescue and Self-Rescue Systems, Subsystems and Components.

Source: U.S. Department of Labor, OSHA, Directorate of Standards and Guidance, Office of Regulatory Analysis-Safety.

At the next decision point, if the final standard differs from the existing requirements, the presence or absence of a “grandfather” provision determines whether employers incur costs to retrofit and upgrade to the new requirements when the standard becomes effective or when employers replace infrastructure or equipment at a time of their choosing. OSHA discusses the cost effects of grandfather provisions in more detail below and in the ERG report (ERG, 2007).

Some equipment addressed by the final standard, such as portable ladders or mobile ladder stands, is commercially available to employers in ready-to-use condition. OSHA believes that manufacturers design and fabricate such equipment, in virtually all cases, to meet current consensus standards because equipment manufacturers seek to avoid: (1) The small market represented by employers that would purchase non-compliant equipment, and (2) the liabilities associated with manufacturing non-compliant equipment.

Typically, employers use architects, engineers, and/or contractors to design, fabricate, and install certain types of site-specific equipment. While it is conceivable that an employer might insist on installing nonconforming equipment, OSHA believes that professional standards for architects and engineers, local building codes, and potential liability concerns dictate that virtually all employers voluntarily use equipment conforming to existing national consensus standards. For these reasons, OSHA concludes that compliant equipment will be available to meet the final requirements of

subparts D and I. For example, final § 1910.23(b)(1) specifies that ladder rungs and steps must be parallel, level, and uniformly spaced when the ladder is in a position for use. While existing § 1910.25(c)(2)(i)(b) covers steps, no existing OSHA standard covers rungs. However, current national consensus standards cover both rungs and steps (see Table V–16).

Likewise, the spacing requirements for the steps of step stools and the rungs, steps, and cleats of ladders covered by final paragraphs § 1910.23(b)(3) and (4) are new (*i.e.*, not in the existing standard); however, the current consensus standard for ladders includes these spacing requirements. Similarly, final § 1910.23(d)(7) requires that grab bars on fixed ladders extend 42 inches (1.1 m) above the access level or landing platform served by the ladder. While the existing standard does not have a similar provision, the provision is in the ANSI 14.3–2008 standard for fixed ladders. Therefore, OSHA did not assign costs to final § 1910.23(d)(7).

In conclusion, for establishing a baseline, OSHA assumed that equipment and work practices met the national consensus standard in effect at the time of installation, and did not estimate costs when the provisions in the final standard and the current national consensus standards were equivalent. For additional analysis of the interface between national consensus standards and OSHA standards, see ERG, 2007, pp. 3–6 and 3–14.

c. Compliance Using the Least-Cost Method

Consistent with past practice, OSHA assumed that employers would meet a

regulatory requirement by choosing the least expensive means to do so. For example, under final § 1910.28(b)(1), an employer can meet the duty to have fall protection for an employee on a walking-working surface with an unprotected side or edge by using: (A) Guardrail systems, (B) safety net systems, or (C) personal fall protection systems such as personal fall arrest, travel restraint, or work-positioning systems. If (A)–(C) are not feasible or create a greater hazard for residential roofing work, the final standard permits a fourth option, *i.e.*, developing and implementing a specified fall protection plan. The existing standard only specifies options (A)–(C); therefore, OSHA assigned no costs to § 1910.28(b)(1) except when there were ambiguities in the scope of the existing standard, such as its application to loading docks or teeming platforms.

In some cases, when the final rule gives an employer a lower-cost compliance option than is currently available, the employer could realize a cost savings. However, OSHA did not estimate such savings in this analysis.

d. No Costs Due to Grandfathering Provision

Table V–17 lists the paragraphs in the final standard with new requirements, but which also have a “grandfather” provision for existing conditions. A grandfather provision exempts equipment that currently is in place from requirements that strengthen or upgrade the safety features of the equipment. Therefore, employers do not incur costs associated with modifying or replacing equipment covered by these paragraphs.

Table V-17
**Paragraphs in Final Subpart D with Grandfather or Delayed-
 Implementation Provisions**

Paragraph	Subject
§1910.24(a)(1)	The employer must ensure that step bolts installed on or after January 17, 2017 in an environment where corrosion may occur are constructed of, or coated with, material that protects against corrosion.
§1910.24(a)(7)	The employer must ensure that step bolts installed on or after January 17, 2017 are capable of supporting at least four times their maximum intended load.
§1910.24(b)(1)	The employer must ensure that manhole steps are capable of supporting their maximum intended load.
§1910.24(b)(2)	The employer must ensure that manhole steps installed on or after January 17, 2017: (i) Have a corrugated, knurled, dimpled, or other surface that minimizes the possibility of an employee slipping; (ii) are constructed of, or coated with, material that protects against corrosion in an environment where corrosion may occur; (iii) have a minimum clear step width of 10 inches (25 cm); (iv) are uniformly spaced at a vertical distance not more than 16 inches (41 cm) apart, measured center to center between steps. The spacing from the entry and exit surface to the first manhole step may differ from the spacing between the other steps; (v) have a minimum perpendicular distance between the centerline of the manhole step to the nearest permanent object in back of the step of at least 4.5 inches (11 cm); and (vi) are designed, constructed, and maintained to prevent the employee's foot from slipping or sliding off the end.

Table V-17
Paragraphs in Final Subpart D with Grandfather or Delayed-
Implementation Provisions (continued)

Paragraph	Subject
§1910.25(b)(5)	The employer must ensure that, when a door or a gate opens directly on a stairway, a platform is provided, and the swing of the door or gate does not reduce the effective usable depth to: (i) Less than 20 inches (51 cm) for platforms installed before January 17, 2017; and (ii) less than 22 inches (56 cm) for platforms installed on or after January 17, 2017.
§1910.26(b)	The employer must ensure that dockboards put into service on or after January 17, 2017 are designed, constructed, and maintained to prevent transfer vehicles from running off the dockboard edge. Exception: When the employer demonstrates there is no hazard of transfer vehicles running off the dockboard edge, the employer may use dockboards that do not have run-off protection.
§1910.28(b)(9)	The employer must ensure: (A) <u>Existing fixed ladders</u> . Each fixed ladder installed before November 19, 2018 is equipped with a personal fall arrest system, ladder safety system, cage, or well; (B) <u>New fixed ladders</u> . Each fixed ladder installed on or after November 19, 2018, is equipped with a personal fall arrest system or a ladder safety system; (C) <u>Replacement</u> . When a fixed ladder, cage, or well, or any portion of a section thereof, is replaced, a personal fall arrest system or ladder safety system is installed in at least that section of the fixed ladder, cage, or well where the replacement is located; and (D) <u>Final deadline</u> . On and after November 18, 2036, all fixed ladders are equipped with a personal fall arrest system or a ladder safety system.
§1910.29(f)(1)(ii)	The employer must ensure: (A) The height of stair rail systems installed before January 17, 2017 is not be less than 30 inches (76 cm) from the leading edge of the stair tread to the top surface of the top rail; and (B) the height of stair rail systems installed on or after January 17, 2017 is not less than 42 inches (107 cm) from the leading edge of the stair tread to the top surface of the top rail.

Source: U.S. Department of Labor, OSHA, Directorate of Standards and Guidance, Office of Regulatory Analysis-Safety.

4. Cost Impacts for Final Subparts D (Walking-Working Surfaces)

This subsection provides a brief paragraph-by-paragraph review of the final rule. OSHA took a two-step approach to determining the cost impacts of the final rule. First, the Agency looked at requirements that represent changes from the existing walking working surfaces and personal protective equipment standards to determine whether they might involve additional incremental costs. That analysis is described in this subsection and subsection 5. In subsection 6, “Cost Estimates,” OSHA discusses how it reached an estimate of the costs for each provision OSHA identified as involving additional costs.

Table V–18 summarizes the paragraphs in the final subparts D and I that represent changes from the

existing standards and might result in costs to employers if current industry practice falls short of the requirements of the rule. In the PEA, these costs primarily involved inspection and training; for this FEA, OSHA also identified significant costs for engineering and administrative controls and personal protective equipment. For the purpose of this analysis, OSHA distinguished between informal and formal training. For example, final § 1910.23(b)(11) states that an employee must face the ladder when ascending or descending. For this provision, OSHA assumed that employers provide such instruction on an in-house basis (*e.g.*, “on-the-job” training), using materials such as OSHA training videos. When employers deliver training on an ongoing, less formal basis, OSHA did not assign a tracking or recordkeeping

cost to it. However, as indicated in the table, OSHA attributed employer costs (and employee benefits, as discussed later in this FEA) to such provisions, where OSHA judged that additional training would be required beyond baseline practice.¹²² When the regulatory text uses the words “trained” or “training,” OSHA assumed that employers would deliver the instruction on a more formal basis, possibly hiring a contractor to deliver the training. OSHA assumed that an employer would maintain documentation of all formal training and, thus, assigned a cost for this administrative task.

¹²² See the discussion later in this section and Ex. [OSHA Excel Workbook], tabs *one_time_23* and *annual_23*, for details on the training costs attributed to the final requirements for ladders under § 1910.23(b) and (c).

Table V-18
Paragraphs of the Final Standards for Subparts D and I Evaluated Further for
Cost Impacts

Paragraph	Subject
§1910.22(b)	The employer must ensure that each walking-working surface can support the maximum intended load for that surface.
§1910.22(d)(1)	The employer must inspect walking-working surfaces regularly and as necessary, and maintain them in a safe condition.
§1910.22(d)(2)	The employer must correct and repair any hazardous conditions on walking-working surfaces before employees use the surfaces. If the employer cannot make the correction or repair immediately, then they must guard the hazardous conditions to prevent employees from using the surfaces until the hazard is corrected or repaired.
§1910.22(d)(3)	The employer must ensure that a qualified person performs or supervises any correction or repair that involves the structural integrity of the walking working surface.
§1910.23(b)(11)	The employer must ensure that when ascending or descending a ladder, the employee faces the ladder. [This is a training requirement.]
§1910.23(b)(12)	The employer must ensure that each employee uses at least one hand to grasp the ladder when progressing up and down the ladder. [This is a training requirement.]
§1910.23(b)(13)	The employer must ensure that an employee climbing up or down a ladder must not carry any object or load that could cause the employee to lose balance and fall. [This is a training requirement.]
§1910.23(c)(5)	Employers may not use portable, single-rail ladders. [This is a training requirement.]
§1910.23(c)(6)	The employer must ensure that ladders are not moved, shifted, or extended while occupied by employees. [This is a training requirement.]
§1910.23(c)(9)	The employer must ensure that ladders used on slippery surfaces are secured and stabilized. [This is a training requirement.]
§1910.23(c)(10)	The employer must ensure that both rails support the top of non-self-supporting ladders, unless the ladder is equipped with a single support attachment. [This is a training requirement.]
§1910.23(c)(11)	The employer must ensure that the side rails of a ladder used to access an upper landing extend at least 3 feet above the landing surface. [This is a training requirement.]
§1910.23(e)(1) – (e)(3)	The employer must ensure mobile ladder stands and platforms meet requirements for such design specifications as step width, load capacity, work surface height, and the provision of stair handrails.

Table V-18
Paragraphs of the Final Standards for Subparts D and I Evaluated Further for
Cost Impacts (continued)

Paragraph	Subject
§1910.23(e)(1)(viii)	The employer must ensure that mobile ladder stands and platforms are not moved when occupied by an employee. [This is a training requirement.]
§1910.24(a)(8)	The employer must inspect ¹²³ each step bolt at the start of the workshift and maintain the step bolts in accordance with §1910.22.
§1910.24(b)(2)(i)	The employer must provide manhole steps with slip resistant surfaces.
§1910.24(b)(2)(ii)	The employer must provide manhole steps that are protected against corrosion
§1910.24(b)(2)(vi)	The employer must ensure that manhole steps are designed, constructed, and maintained to prevent the employee's foot from slipping or sliding off the end of the manhole step.
§1910.24(b)(3)	The employer must inspect ¹²⁴ each manhole step before each workshift and maintain the steps in accordance with §1910.22.
§1910.27(b)(2)(iii)	The employer must ensure that employees who use rope descent systems receive training in accordance with §1910.30.
§1910.27(b)(2)(iv) and (b)(2)(v)	The employer must ensure that rope descent systems used by employees are inspected at the start of each workshift and have proper rigging, including anchorages and tiebacks.
1910.28(b)(1)	Employee must be protected while working on a surface with an unprotected side or edge from falling 4 feet (1.2 m) or more to a lower level.
§1910.28(b)(4)(i)	The employer must install guardrails or handrails on dockboards.
§1910.28(b)(9)(i)(A)-(D)	Employers must ensure that existing, new, and replaced ladders and ladder sections are equipped with the specified fall protection systems, cages, or wells (depending on implementation date, cages and wells may not be considered fall protection systems).
§1910.28(b)(10)(ii)(A)	The employer must ensure that each employee who climbs fixed ladders on billboards receives the training and demonstrates the physical capability to perform the necessary climbs in accordance with §1910.29(h).

¹²³ The requirement in the proposed standard that step bolts be “visually inspected” was revised in the final standard to read that step bolts be “inspected.”

¹²⁴ The requirement in the proposed standard that manhole step be “visually inspected” was revised in the final standard to read that manhole steps be “inspected.”

Table V-18
Paragraphs of the Final Standards for Subparts D and I Evaluated Further for
Cost Impacts (continued)

Paragraph	Subject
§1910.28(b)(10)(ii)(C)	The employer must ensure that employees have both hands free of tools or material while ascending or descending fixed ladders on billboards. [This is a training requirement.]
§1910.28(b)(13)	The employer must protect employees from falls on low slope roof by using a guardrail systems, safety net system, travel restraint system, personal fall arrest system, or designated area .
§1910.28(b)(14)(i)	The employer must protect employees on slaughtering facility platforms falling 4 feet or more by using: (A) Guardrail systems; or (B) Travel restraint systems.
§1910.28(b)(15)	The employer must protect employees from fall hazards on surfaces not otherwise addressed through guardrails, safety net systems, or personal protection systems.
§1910.29(b)(15)	The employer must inspect top rails or midrails made of manila or synthetic rope to ensure the rope continues to meet strength requirements
§1910.29(h)(1)	Employers must determine, through observation of actual climbing activities or by physical examination, that each employee who climbs a fixed ladder in outdoor advertising operations is physically capable of performing the assigned duties.
§1910.29(h)(2)	Employers must train, and retrain as necessary, employees to safely climb fixed ladders in outdoor advertising operations.
§1910.30(a)	The employer must provide training for each employee who uses personal fall protection systems or who requires training as specified elsewhere in the standard before exposing the employees to fall hazards.
§1910.30(b)	The employer must train each employee on the proper: care, inspection, storage, and use of equipment covered by the standard before the employee uses the equipment such as dockboards, rope descent systems, and designated areas.
§1910.30(c)	The employer must retrain an employee when the employer has reason to believe that the employee does not have the understanding and skills required by paragraphs (a) and (b) of §1910.30.
§1910.132(d)	The employer must conduct a hazard assessment of the workplace to determine the need for personal fall protection equipment; select, and have affected employees use, the requisite personal fall protection equipment; communicate the selection decisions to each affected employee; select equipment that fits the affected employees properly; and verify in writing that the hazard assessment was performed.

Table V-18
Paragraphs of the Final Standards for Subparts D and I Evaluated Further for
Cost Impacts (continued)

Paragraph	Subject
§ 1910.132(f)	The employer must provide training to each employee who is required to use fall protection equipment.
§ 1910.140(c)(18)	The employer must inspect personal fall protection systems before their initial use each workshift for mildew, wear, damage, and other deteriorations, and remove defective systems from service.

Source: U.S. Department of Labor, OSHA, Directorate of Standards and Guidance, Office of Regulatory Analysis-Safety.

Finally, three requirements in the standard specify that employers must provide training in accordance with § 1910.30 or the equivalent:

- § 1910.27(b)(2)(iii): Rope descent systems;
- § 1910.28(b)(1)(ii)(C): Unprotected sides and edges; and
- § 1910.28(b)(4)(ii)(C): Dockboards.

The costs for § 1910.30 include the costs for the three paragraphs listed above.

In the following subsection, organized by regulatory provision, OSHA discusses the potential cost implications of the new requirements. OSHA described earlier in this cost analysis final changes to the existing standard that likely will result in little or no costs; OSHA does not address these changes in the discussion below.

General Requirements (§ 1910.22)

§ 1910.22(b). This provision specifies general requirements, one of which is that employers must ensure that the walking-working surface has the strength to support employees safely. From the standpoint of compliance costs, OSHA believes that employers can meet this requirement by performing a 5- to 10-minute inspection of the surface or reviewing engineering diagrams of the structure. In rare circumstances, an employer might need to spend 15 to 30 minutes determining if the work can proceed. OSHA discusses the costs for this provision later in this subsection in connection with the duty to inspect walking-working surfaces as part of the general requirements specified under § 1910.22(d) (see “Cost estimates” below).

§ 1910.22(c). The employer must provide employees with, and ensure that they use, a safe means of access to, and egress from, one walking-working surface to another. The language in existing § 1910.22(b) specifies that

employers must keep aisles and passageways clear, in good repair, and with no obstruction across or in the aisles that could create a hazard to employees. For the PEA, OSHA generalized the terms “aisles” and “passageways” in proposed § 1910.22(c) to cover all means of access and egress. The terminology in the proposed rule was consistent with that in a National Fire Protection Association consensus standard (NFPA 101). Thus, OSHA assigned no costs to proposed § 1910.22(c) in the PEA and, with no comment in the record objecting to that decision, OSHA assigned no costs to § 1910.22(c) in this FEA.

§ 1910.22(d). This new provision sets forth requirements for the employer to inspect regularly and as necessary, and maintain in a safe condition, walking-working surfaces; guard hazardous conditions to prevent employee use until the employer corrects or repairs the hazard; and have a qualified person inspect perform or supervise any correction or repair work that involves the structural integrity of a walking-working surface. OSHA considered the costs for these safe work practices below under “Cost estimates” (for the duty to have fall protection; § 1910.28).

Ladders (§ 1910.23)

§ 1910.23(a). This paragraph specifying the application final standard covers all ladders, except when the ladder is used in emergency operations such as firefighting, rescue, and tactical law enforcement operations, or training for these operations or designed into or is an integral part of machines or equipment. Special wood ladders specifically excluded in the existing standard, including fruit picker’s ladders, combination step and extension ladders, stockroom step ladders, aisleway step ladders, shelf ladders, and library ladders are now included under the final standard. In the PEA, OSHA

assumed that these ladders met consensus standards for wooden ladders (see Table V–16) and, therefore, OSHA expected that employers would incur no costs with the expanded application. After reviewing the record, OSHA reached the same conclusion for this FEA.

Final § 1910.23(b)(4) specifies a minimum clear rung, step, or cleat width of 11.5 inches for portable ladders and 16 inches for fixed ladders; thus, the distance from the centerline to the inside edge of the ladder ranges from roughly 6 to 8 inches. Adding the existing requirement of 2.5 inches from the nearest edge of the ladder to the nearest edge of the structure or equipment to the 6- to 8-inch centerline width required by the final standard results in a step-across width of 8.5 to 10.5 inches for the purposes of the final standard. Thus, any fixed ladder that meets the existing requirements also meets the final requirements. OSHA assigned no costs to this paragraph in the PEA. Therefore, absent comment by the public or any other evidence in the record that would alter this preliminary assessment, the Agency assigned no costs for this paragraph in this FEA.

§ 1910.23(b)(4)(iii). This paragraph concerns rolling ladders in communications centers, which OSHA moved to this final rule from existing § 1910.268(h)(5), Telecommunications. Thus, as this is not a new requirement, it has no costs.

§ 1910.23(b)(4)(iv). This paragraph is a new requirement that addresses the minimum clear width for stepstools, which OSHA defines as a type of portable ladder (§ 1910.21(b)). The final rule specifies that stepstools must have a minimum clear width of at least 10.5 inches instead of the 11.5-inch minimum clear width that the final rule requires for other portable ladders. Although OSHA did not receive any comments on this issue, the Agency

added this provision to make the rule consistent with ANSI/ALI national consensus standards for wood and metal portable ladders (A14.1–2007 and A14.2–2007). OSHA assigned no costs to this paragraph in the PEA, and absent comment by the public or any other evidence in the record that would alter this preliminary assessment, the Agency assigned no costs for this paragraph in this FEA.

§ 1910.23(b)(9). Both the existing and proposed standards had a requirement to inspect ladders before use. In the PEA, OSHA determined that the inspection frequency would not increase under the proposed standard. Therefore, OSHA concluded that employers would incur no additional costs associated with this requirement and, after reviewing the record following publication of the NPRM, reached the same conclusion for this FEA.

§ 1910.23(b)(11)–(13); § 1910.23(c)(5) and (6) and (9)–(11). These eight paragraphs include instructions to employees on the proper use of ladders. Final § 1910.23(c)(5) prohibits the use of single rail ladders, which OSHA finds is a training requirement. The wide availability of permitted ladders means that there are no equipment costs associated with this prohibition. In the PEA, OSHA also concluded that training would cover the other six provisions, and reached the same conclusion for this FEA. OSHA considered training costs below under “Cost estimates.”

§ 1910.23(c)(12) and (13). These provisions state that employers are not to tie or fasten ladders and ladder sections together to provide added length unless the design of the ladders permits such use, nor are employers to place ladders on boxes, barrels, or other unstable bases to obtain additional height. These provisions are essentially identical to current paragraphs §§ 1910.25(d)(2)(v) and 1910.26(c)(3)(vi), which specify that neither wood nor metal portable ladders may be spliced, tied, or fastened together or elevated on unstable surfaces to create a longer section or higher reach unless the manufacturer has designed the equipment for such a purpose. These provisions, both in the existing and final standards, might cause employers to incur a cost if it is necessary to purchase longer ladders, or ladders that they can fasten together. During the comment period, OSHA received no data estimating the frequency of such occurrences but, presumably, they are rare. Thus, OSHA did not assign a cost to these paragraphs in this final analysis.

§ 1910.23(d)(1). As proposed, fixed ladders installed 90 days after the effective date of the final standard must be capable of supporting two live loads of at least 250 pounds each, additional concentrated loads of 250 pounds each, plus anticipated loads caused by ice build-up and other conditions. Each rung must be capable of supporting at least a single concentrated load of 250 pounds. The language in this proposed requirement reflected the consensus standard in ANSI A14.3–2002. The language in the existing standard, however, specifies a single concentrated load of 200 pounds.

As discussed earlier in this preamble, OSHA removed paragraph (d)(2) of the proposed rule from the final rule because OSHA believes that the performance criteria specified in final § 1910.23(d)(1) provide an adequate level of safety for employees. Therefore, because paragraph (d)(1) reflects industry practice as documented in ANSI A14.3–2002, there are no costs associated with this provision.

§ 1910.23(d)(12)(i). This final provision requires that employers measure “step-across distance” from the centerline of the steps or rungs of a fixed ladder. The existing definition measures step-across distance from the nearest edge of the ladder to the nearest edge of the structure or equipment. The minimum distance under the final standard is 7 inches, and under the existing standard it is 2.5 inches; the maximum distance in the final standard is 12 inches, identical to the current standard. OSHA assigned no costs to this paragraph in the PEA and, although the minimum step-across distance in the proposed standard differed significantly from that in the current standard, no commenters objected to the proposed expansion in minimum step-across distance. Therefore, OSHA assigned no costs to this provision in this FEA.

§ 1910.23(d)(12)(ii). The final standard specifies that the step-across distance from the centerline of the steps or rungs of a fixed ladder to the access point of the platform edge for side-step ladders must be not less than 15 and not more than 20 inches. Based on Figure D–10 in the existing standard, the maximum space from the edge of the ladder to the platform (*i.e.*, access point) is 12 inches. As noted in the previous paragraph, the centerline width for a fixed ladder ranges from roughly 6 to 8 inches. The total step-across distance under the existing standard ranges from 18 to 20 inches. Thus, a fixed ladder that meets the existing requirements also meets the final requirements. Therefore, OSHA assigned no costs to this paragraph in the PEA and OSHA

assigned no costs to this provision in this FEA.

§ 1910.23(e). Paragraph (e)(1)(viii) (which impede or prohibit moving occupied mobile ladder stands and platforms) are the only paragraphs in this provision that do not have a corresponding requirement in a national consensus standard. However, these are work practice requirements that employers can meet through ladder safety training and enforcement. See the subsection titled “Cost estimates” below.

All other provisions in § 1910.23(e) meet the national consensus standard in the ANSI A14 series. An analysis of fiscal year 2005 OSHA inspection data for violations of existing subpart D indicate that the failure to provide safe ladders is low (*e.g.*, 0.2 percent of the violations were for portable wood ladders, 0.4 percent were for metal ladders, and 0.8 percent were for fixed ladders). Based on these data, OSHA infers that there is nearly 100 percent compliance with the provisions of the current consensus standards. Therefore, OSHA assigned no costs for equipment upgrades required by these paragraphs. However, OSHA assigned costs for the time it would take to ensure new ladders meet the technical specifications found in § 1910.23(e); see “Cost estimates” below.

Step Bolts and Manhole Steps (§ 1910.24)

The requirements for step bolts are new to subpart D. In the preliminary regulatory impact analysis for the 1990 proposed rule, OSHA noted, “Manufactured products, such as ladders, step bolts, manhole steps . . . generally meet or exceed proposed OSHA specifications” (OSHA, 1990a). A 2003 OSHA interpretation document comments that OSHA believes that the IEEE 1307–1996 consensus standard, in most cases, prevents or eliminates serious hazards (OSHA, 2003a). IEEE 1307–1996 defines “failure” in a step bolt as occurring when it is bent more than 15 degrees below the horizontal, and § 1910.24(a)(9) in the final standard for subpart D mirrors that definition. Because IEEE revised the standard in 2004, OSHA, in the most recent PEA for subparts D and I, assumed that industry was using the more up-to-date consensus standard. For this FEA, OSHA continues to assume that industry is complying with the 2004 IEEE standard.

§ 1910.24(a)(1). This provision reads, “[The employer must ensure:] Each step bolt installed on or after January 17, 2017] in an environment where corrosion may occur is constructed of,

or coated with, material that protects against corrosion.” The national consensus standard applicable to this requirement is ASTM A394–08, Specification for Steel Transmission Tower Bolts, Zinc-Coated and Bare. The appendix to the consensus standard notes that the purchaser shall specify the dimensions of ladder bolts, step bolts, and equipment-support bolts. The ASTM standard describes three types of bolts covered by the standard:

- Type 0: Hot-dip, zinc-coated bolts made of low or medium carbon steel (ASTM 394–08, Section 1.1.1);
- Type 1: Hot-dip, zinc-coated bolts made of medium carbon steel, quenched and tempered (ASTM 394–08, Section 1.1.2); and
- Type 3: Bare (uncoated), quenched and tempered bolts made of weathering steel (ASTM 394–08, Section 1.1.4).¹²⁵

Appendix A.2 of the consensus standard mentions that bolts should be Type 0 unless agreed upon by the manufacturer and purchaser. That is, the default condition is to use zinc-coated bolts; therefore, such bolts would meet the OSHA requirement for corrosion resistance. Presumably, the use of any other bolt type means that the manufacturer and purchaser agreed that the bolt is appropriate for the intended environment and use. Since manufacturers of step bolts are unlikely to make non-compliant step bolts, OSHA assigned no costs to § 1910.24(a)(1) in the PEA and also assigned no cost to this provision in this FEA.

§ 1910.24(a)(6). This provision reads, “[The employer must ensure:] Each step bolt installed before January 17, 2017 is capable of supporting its maximum intended load.” In the final standard, OSHA revised the proposed text by reducing the implementation period after the publication date of the final standard from 90 days to 60 days, a

¹²⁵ ATSM removed type 2 bolts from the standard in 2005.

change that OSHA believes will not impose significant costs on employers.

The requirement that a step bolt must be capable of supporting its maximum intended load is consistent with IEEE 1307–2004, Standard for Fall Protection for Utility Work. Section 9.1.1.1(d) in that standard reads:

Step bolts shall [b]e capable of supporting the intended workload [as defined for the application specified by the appropriate ANSI standard(s)], but in no case shall the minimum design live load be less than a simple concentrated load of 271 kg (598.4 lb) applied 51 mm (2 inches) from the inside face of the step bolt head.

Therefore, OSHA assigned no costs to this provision in the PEA and, after considering all factors associated with this provision, did not alter this estimation for this FEA.

§ 1910.24(a)(7). This paragraph requires that step bolts installed on or after 60 days after publication of the final rule be capable of supporting four times their maximum intended load. As discussed in the preamble to the proposed rule, OSHA considered a 5/8-inch bolt as meeting this requirement, and bolts of that size are readily available. Therefore, in the PEA OSHA determined that there would be no incremental costs associated with this provision.

In prehearing comments, The Southern Company questioned OSHA’s proposed load criterion, stating, “Instead of using the four times the maximum intended load, OSHA should consider using the criteria of the NESC or IEEE 1307” (Ex. 192, p.3). OSHA noted earlier in the summary and explanation for this paragraph that, under this performance-based final rule, employers may use a range of methodologies, including criteria found in consensus standards, to determine the load capabilities of step bolts. Therefore, since bolt manufacturers are producing bolts that meet these design criteria, OSHA believes that there will be little, if any, additional cost burden

on employers who must use step bolts that meet OSHA’s load requirement, and, therefore, assigned no compliance costs to this provision in the final rule.

§ 1910.24(a)(8) and § 1910.24(b)(3). Under these paragraphs of the final standard, employers must inspect step bolts and manhole steps at the start of each workshift. OSHA considered inspection costs below under “Cost estimates.”

§ 1910.24(b). Table V–19 summarizes the language in the final standard for manhole steps, along with the corresponding section of ASTM C478–13. The following three requirements in this provision exceed the requirements specified in a national consensus standard for steps in precast concrete manhole sections:

- Manhole steps must have slip-resistant surfaces such as corrugated, knurled, or dimpled surfaces;
- Manhole steps must be constructed of, or coated with, material that protects against corrosion in an environment where corrosion may occur; and
- The design of manhole steps must prevent the employee’s foot from slipping or sliding off the end of the manhole step.

ASTM C478–13 permits the use of uncoated or untreated ferrous steps as long as they are at least 1 inch in cross-section, but is silent with regard to a slip-resistant surface or design. Because the final requirements appear to exceed the requirements in the consensus standard, the PEA determined that there would be incremental costs for slip-resistant and corrosion-resistant surfaces when employers rebuild or replace a manhole section. Moreover, the specifications in the final standard, unlike the consensus standard, define when a step fails while still in the manhole; thus, as noted in the PEA, there would also be step replacement costs associated with this provision. OSHA discusses these costs below under “Cost estimates.”

Table V-19 Manhole Steps

Provision	Language	Related ASTM C478-13
§1910.24(b)(1)	The employer must ensure that manhole steps are capable of supporting their maximum intended load.	16.6.1.3
§1910.24(b)(2)	The employer must ensure that manhole steps installed on or after January 17, 2017.	
§1910.24(b)(2)(i)	Are provided with slip-resistant surfaces such as corrugated, knurled, or dimpled surfaces.	
§1910.24(b)(2)(ii)	Are constructed of, or coated with, material that protects against corrosion in an environment where corrosion may occur.	16.5.1
§1910.24(b)(2)(iii)	Have a minimum clear step width of 10 inches (25 cm).	16.5.2
§1910.24(b)(2)(iv)	Are uniformly spaced at a vertical distance of not more than 16 inches (41 cm) apart, measured center to center between steps. The spacing from the entry and exit surface to the first manhole step may differ from the spacing between the other steps.	16.4.1
§1910.24(b)(2)(v)	Have a minimum perpendicular distance between the centerline of the manhole step to the nearest permanent object in back of the step of at least 4.5 inches (11 cm).	16.5.3 ¹²⁶
§1910.24(b)(2)(vi)	Are designed, constructed, and maintained to prevent the employee's foot from slipping or sliding off the end.	
§1910.24(b)(3)	The employer must ensure that manhole steps are inspected before initial use during a workshift, and is maintained in accordance with §1910.22.	

(a) Empty cells in this column indicate that no comparable ASTM C478-13 provision exists.

Source: U.S. Department of Labor, OSHA, Directorate of Standards and Guidance.

¹²⁶ ASTM C478-13, Section 16.5.3, specifies that the rung or cleat shall project a uniform clear

distance of four inches minimum ±¼ in. from the wall to the embedment side of the rung. The OSHA distance in the final standard measures from the centerline of the manhole step. Thus, if a step is at

least an inch wide, a step that meets the ASTM 4-inch requirement also would meet the OSHA 4.5-inch requirement.

Stairways (§ 1910.25)

§ 1910.25(b)(5). The existing standard states that employers must provide a platform for doors or gates that open directly onto a stairway, and the swing of the door must not reduce the effective width to less than 20 inches. In the final standard, platforms installed before 60 days after the publication date of the final rule need only comply with the existing requirements; therefore, there are no retrofit costs to employers. For platforms installed on or after 60 days from the publication date of the final rule, the effective width increases to 22 inches.¹²⁷ Employers will have an incremental cost when replacing a platform with one that has two inches of additional clearance.

Commenting on the proposed revision to this paragraph, Ameren Corporation expressed concern about the proposed 90-day grandfathering timeline:

Lead time for material orders are often quite longer than three months often up to years to order material for large capital projects. Small projects with possibly only a small amount of material being required shouldn't have much of an issue of complying depending on the manufacturer capabilities and their imposed deadlines. Stipulations of "ordered" material should be imposed in regard to the date of the final rule because the time between ordering and placing into service is often greater than 90 days. (Ex. 189, p. 6.)

In response, OSHA recognizes that, as Ameren indicates, some large projects may require a lead-time longer than 60 to 90 days. However, OSHA also believes that most, if not all, manufacturers of such platforms should be familiar with the associated consensus standard, ANSI A1264.1–2007, and, therefore, produce platforms now that meet the 22-inch clearance requirement. OSHA believes that most contracts, as a usual and customary practice, already incorporate into the cost of the product the minimal increase in material cost borne by the employer to meet the clearance specification. For the reasons given above under the subsection titled "Compliance with national consensus standards," OSHA estimated no incremental costs for this provision (§ 1910.25(a)(6)) in the PEA and, for these same reasons, did not take incremental costs for the provision (§ 1910.25(b)(5)) in the final standard.

§ 1910.25(d). Existing § 1910.24(b) does not permit spiral stairways except under special conditions. Employers cannot use spiral stairs under final § 1910.25(d) unless the stairs meets

specific design specifications.

Therefore, employers must modify or replace existing spiral staircases that do not meet these requirements. However, spiral staircases are likely to be relatively rare in commercial or industrial settings given that they are exceptions to the existing rule. Thus, OSHA did not assign costs to § 1910.25(d) in the PEA. Given that no commenters objected to this preliminary cost estimate, OSHA is estimating no costs for this paragraph in this FEA.

§ 1910.25(e). OSHA developed this paragraph in response to a comment made to an OMB-initiated, government-wide effort to reform regulation in the U.S. manufacturing sector. This comment, submitted by the Copper and Brass Fabricators Council, stated that OSHA required the use of fixed stairs when ship stairs or spiral stairways would be safer (OMB, 2005).

Employers typically install ship stairs with slopes of 50 degrees or greater; however, the existing standard for fixed stairs addresses stairs installed at angles between 30 and 50 degrees, but does not specifically address ship stairs. Recently, OSHA issued an interpretation stating that if ship stairs conformed to the 1990 proposed standard for subpart D,¹²⁸ the Agency would consider slopes up to 70 degrees to be *de minimis* violation of the existing standard¹²⁹ (OSHA, 2006b and 2006c). OSHA believes that most existing ships stairs conform to the 1990 proposed standard, and therefore the Agency assigned no costs to § 1910.25(e) in the PEA, nor did it assign costs to § 1910.25(e) in this FEA.

§ 1910.25(f). The existing standard does not expressly mention alternating tread-type (tread) stairs. A letter of interpretation from OSHA to a manufacturer of alternating tread stairs concluded that these stairs are safe (OSHA, 1981). NFPA 101, Section 7.2.11 (NFPA, 2012) also addresses alternating tread stairs. As discussed in the PEA, any alternating tread stair that meets the requirements of NFPA 101 would also meet the requirements in § 1910.25(f); accordingly, the PEA determined that this provisions does not impose a new cost burden on

¹²⁸ The 1990 proposed standard allowed ship stairs that are designed with slopes between 50 degrees and 70 degrees from the horizontal; have open risers; have treads that are four inches (10 cm) in depth, 18 inches (46 cm) in width, and a vertical rise between tread surfaces of six and one-half inches to 12 inches (16 cm to 30 cm); and have handrails that are installed on both sides of the ship stairs and meet § 1910.28 (within the existing standard). (55 FR 13400.)

¹²⁹ See OSHA's Field Operation Manual: https://www.osha.gov/OshDoc/Directive_pdf/CPL_02-00-148.pdf.

¹²⁷ The 22-inch clearance requirement for new structures matches ANSI A1264, Section 6.11.

employers. Thus, in this FEA, OSHA did not assign costs to this provision.

Dockboards (§ 1910.26)

§ 1910.26(b). The text for this provision states that the employer must ensure dockboards put into initial service on or after January 17, 2017 are designed, constructed, and maintained to prevent transfer vehicles from running off the dockboard edge. Exception: When the employer demonstrates there is no hazard of transfer vehicles running off the dockboard edge, the employer may use dockboards that do not have run-off protection.

The definition of a dockboard in ANSI MH30.2–2005, Section 2.2, contains the language "as well as providing a run-off guard, or curb," similar to the requirement in this final provision. OSHA believes, as it stated in the PEA, that nearly all dockboards manufactured currently conform to the ANSI standard; however, should an employer encounter an older, out-of-compliance dockboard, OSHA believes that the costs for them to comply with the final standard will be minimal. Therefore, in the absence of comment on this analysis, OSHA is not assigning costs in this FEA for final § 1910.26(b).

§ 1910.26(e). The text for this provision reads, "[The employer must ensure:] Portable dockboards are equipped with handholds or other means to permit safe handling of dockboards." The requirement in final § 1910.26(e) that portable dockboards have handholds or other means to permit safe handling is essentially the same requirement specified in existing § 1910.30(a)(4), which OSHA based on ANSI/ASME B56.1, American Society of Mechanical Engineers, Safety Standard for Low Lift and High Lift Trucks. Therefore, OSHA believes that commercial dockboards likely come equipped with handholds and that any additional costs associated with this provision will be minimal. Thus, OSHA in this FEA did not assign costs for final § 1910.26(e).

Scaffolds and Rope Descent Systems (§ 1910.27)

§ 1910.27(a). This paragraph extends the construction industry requirements for scaffolds (except rope descent systems) to general industry. OSHA believes that many general industry employers who use scaffolds also perform work covered by the construction industry standards and are already familiar, and in compliance, with the construction industry scaffold standards. Therefore, linking the final standard for scaffolds in general

industry to the scaffold requirements in 29 CFR part 1926 resolves any inconsistencies between the scaffold requirements for the construction and general industries. OSHA received no comment on this analysis in the PEA. Thus, as in the PEA, OSHA attributed no costs to this paragraph in this FEA.

§ 1910.27(b)(1). When employers use rope descent systems (RDS; also known as controlled-descent devices) for building maintenance, the final standard requires that the building owner or its representative provide to the building-maintenance contractor (the employer) written documentation of identified, tested, certified, and maintained anchorages capable of supporting at least 5,000 pounds (268 kg), in any direction, for each employee attached. As OSHA noted in the PEA, it would appear from the documentation associated with the industry consensus standard, ANSI/IWCA I-14.1, that the International Window Cleaning Association (IWCA) customarily finds from information its members receive that many buildings lack the required anchorages. A key provision of that consensus standard is a written work plan (Section 1.7), and the IWCA Web site urges window cleaning enterprises to develop written plans and coordinate their operations with building owners. Accordingly, the IWCA Web site states:

The intent of the [IWCA I-14.1] standard was not to stop window cleaning, it was to improve the level of safety of our industry by having a shared responsibility between the window cleaner and the building owner. If you have outdated equipment or are using equipment that doesn't meet the standard, phase it out. If you have buildings you're working on that are dangerous and are using creative rigging, phase them out and work with the building owners toward compliance. (IWCA, 2014.)

ANSI/IWCA I-14.1, Section 17, lists options for roof support equipment, including:

- Parapets, cornices, and building anchorages (Section 17.1);
- Davits and davit fixtures (a crane-like structure, Section 17.2);
- Sockets (Section 17.3);
- Tiebacks (Section 17.4);
- Counterweighted outriggers (Section 17.5);
- Parapet clamps and cornice hooks (Section 17.6); and
- Overhead monorail tracks and trolleys (Section 17.7);

Several of these options, such as counterweighted outriggers, are transportable and likely supplied by the contractor. Thus, the work plan delineates how the employer is to perform the work using a mix of contractor and property-owner

equipment. The consensus standard provides several acceptable options for roof support equipment, and specifies that both the contractor and property owner concur with the work plan, and that the work plan describe how the contractor will perform the job safely. For the PEA, OSHA presumed that voluntary compliance with the consensus standard is likely to be high. However, as described in detail below, comments in the record indicate that industry compliance with the provision for sound anchorages varies considerably. In the PEA, OSHA assigned no costs for equipment; however, the Agency did estimate costs for inspections and certification that anchorages meet requirements. OSHA discusses these costs below in the subsection titled "Cost estimates."

§ 1910.27(b)(2)(i). Rope descent systems are an alternative to powered platforms. The final rule states that employers cannot use rope descent systems at heights greater than 300 feet unless they demonstrate that it is not feasible to access such heights by any other means or that those means pose a greater hazard to employees than using a rope descent system. The wording of the final rule is consistent with the industry consensus standard, ANSI/IWCA I-14.1, 2001. Accordingly, both the IWCA consensus standard and the final OSHA standard (1) prohibit the use of rope descent systems for descents exceeding 300 feet, and (2) contain an exclusion clause, which, in the case of the IWCA standard, provides that the requirement apply unless "access cannot safely and practicably be obtained by other means." Because both the IWCA and OSHA standards contain a similar exclusion clause, the OSHA requirement is no more restrictive than the consensus standard.

Since this is a work-practice as opposed to an equipment-specification requirement, incremental costs are attributable to the OSHA standard only to the extent that employers would not voluntarily comply with the IWCA standard and to the extent that employers provide excess-risk documentation to OSHA. Employers, therefore, would incur costs from this provision only when (1) a building is 300 feet tall or higher, and (2) there is an alternative to the rope descent system that is feasible and at least as safe as an RDS. For the PEA, ERG examined a database developed by the Council on Tall Buildings and Urban Habitat (CTBUH) and identified slightly more than 1,900 buildings in the United States that are 300 feet (91.7 m) tall or higher (CTBUH, 2006). Over 25 percent of these buildings are in New York City,

where state law does not allow the use of rope descent systems for window cleaning (DiChacho, 2006). Accordingly, ERG derived an estimate of 1,500 potentially affected buildings nationwide (ERG, 2007). For the PEA, OSHA assumed that some of these 1,500 buildings have permanently installed power platforms for access to the exterior of the building, and further assumed that using a platform would be less expensive than setting up an RDS.

For this FEA, OSHA examined the CTBUH database described above and determined that, currently: Approximately 1,960 existing buildings are 300 feet or higher; of that total, roughly 600 buildings with a height of 300 feet or greater are in New York City; and two states—California and Minnesota—have statutes that limit the RDS descent distance to, respectively, 130 feet and 300 feet (CA-DIR, 2012; Minnesota, 2012). After subtracting the number of buildings in those three states from the total, OSHA conservatively estimates that the 300-foot limit specified by this final standard would affect 1,300 buildings with a height of 300 feet or greater.¹³⁰

The final set of buildings for which § 1910.27(b)(2) could result in costs are those buildings for which employers use RDS due to technical factors specific to a building's history, architecture, or style of operation. For example, to wash regularly the windows of a tall building with many sharp angles or tiered levels, management may find it cost-effective to contract for RDS rather than powered platforms. OSHA expects that there will be additional costs to the building owners in these situations because of factors discussed below under "Cost estimates."

§ 1910.27(b)(2)(ii)-(xiii). With one exception, these paragraphs in the final standard codify safety provisions presented in the 1991 memorandum to OSHA's Regional Administrators, which are similar to the requirements now specified in the national consensus standard, ANSI/IWCA I-14.1 (OSHA, 1991b). The safety provisions in this ANSI standard that mirror the OSHA memo are:

- Training employees in the use of the equipment;

¹³⁰ Valcourt Building Services estimated that 2.6 percent of its window washing operations involve buildings that are 300 feet or greater in height (Ex. 358). If OSHA applies that percentage to the number of all commercial buildings subject to the suspended scaffolds standard and, therefore, potentially affected by the 300-foot limit (DOE, 2006), the resulting estimate is significantly greater than the CTBUH estimate. This finding suggests that Valcourt's operations involve an unusually large proportion of buildings that are taller than 300 feet.

- Inspecting the equipment each day before use and removing of damaged equipment from service;
- Using proper rigging, including sound anchorages and tiebacks, in all cases, with particular emphasis on providing tiebacks when using counterweights, cornice hooks, or similar non-permanent anchorage systems;
- Using a separate personal fall arrest system;
- When installing lines, using knots, swages, or eye splices when rigging RDS that are capable of sustaining a minimum tensile load of 5,000 pounds;
- Providing prompt rescue of employees;
- Effectively padding ropes where they contact edges of a building, anchorage, obstructions, or other surfaces that might cut or weaken the rope; and
- Providing stabilization at the work location when descents are greater than 130 feet.

A provision in the OSHA memo not duplicated in the ANSI standard is the requirement in final § 1910.27(2)(b)(xi), which specifies that no employee may use an RDS under hazardous weather conditions, such as storms or gusty or excessive wind. OSHA estimates that this new provision is not likely to present a significant burden on employers because of the relatively high levels of current compliance with the provision (see, for example, Ex. 329 (1/19/2011), pp. 213, 346, 411–412) and the Agency's expectation, based on comments in the record (Ex. 329 (1/19/2011), pp. 235–236, 361), that employers will respond to wind conditions by adjusting window cleaning operations to minimize lost revenue and added project costs (for example, scheduling window cleaning operations on short buildings when weather conditions would create a hazard for window cleaning operations on tall buildings).

The proposed regulatory text updated the 1991 OSHA memo by using terminology such as “prompt rescue” rather than “rescue” and “harness” rather than “body belt,” but, as it stated in the PEA, OSHA did not believe that these revision would increase compliance costs. Other revisions to the 1991 OSHA memo made in the proposal, and now in the final standard, include the addition of three safety provisions to the original list of safety provisions described above. These three provisions include:

- Using equipment in accordance with the instructions, warnings, and design limitations set by manufacturers

or qualified persons (final § 1910.27(2)(b)(ii));

- Securing equipment by a tool lanyard or similar method to prevent equipment from falling (final § 1910.27(2)(b)(xii)); and
- Protecting suspension ropes from exposure to open flames, hot work, corrosive chemicals, or other destructive conditions (final § 1910.27(2)(b)(xiii)).

In the PEA, OSHA stated that the eight safety provisions listed in the 1991 OSHA memo, the provision dealing with wind and other weather hazards, and the additional three provisions described in the previous paragraph, would not impose significant costs on employers. None of the comments submitted to the proposal provided any evidence contradicting this analysis.

OSHA determined in the PEA that the training requirements in proposed § 1910.27(b)(2)(ii), now codified as final § 1910.27(b)(2)(iii), imposed costs on employers. Final § 1910.27(b)(2)(iii) specifies that employers provide training in accordance with § 1910.30. Therefore, OSHA assigned the costs for training beyond that noted in its 1991 memorandum to § 1910.30. OSHA discusses these costs under “Cost estimates” below.

The Agency identified two additional provisions, final § 1910.27(b)(2)(xii) and (b)(2)(xiii), in the PEA as having potential costs.¹³¹ The requirement specified by final § 1910.27(b)(2)(xii) to secure equipment is consistent with consensus standard IWCA I–14.1–2001, Section 3.10. Thus, OSHA did not assign incremental costs to this requirement in either the PEA or this FEA.

The requirement in final § 1910.27(b)(2)(xiii) that employers protect suspension ropes from exposure to open flames, hot work, corrosive chemicals, or other destructive conditions, is an extension of the requirement to protect the integrity of the ropes specified in OSHA's 1991 OSHA memorandum. OSHA attributed the costs for meeting this requirement under the training costs estimated in § 1910.30, and described below under “Cost estimates.”

Duty To Have Fall Protection and Falling Object Protection (§ 1910.28)

The revised regulatory text for final § 1910.28 consolidates the fall protection requirements in the existing rule, with two major revisions. First, comments submitted in response to the reopening of the rule in 2003 recommended that the fall protection

requirements in subpart D be consistent with the requirements in subpart M of the construction standards. The final text for § 1910.28 makes the general industry fall protection requirements consistent with the construction requirements, which may impose additional costs on employers in general industry. In addition, the existing standard does not address the use of restraint systems, designated areas, or safety net systems, nor does the existing standard clarify when employers can use personal fall protection systems. In contrast, the final standard allows employers to choose from various options in providing fall protection, *i.e.*, it is not as restrictive as the existing standard, which primarily requires use of guardrails.

In the proposal, OSHA requested public comment on the expenses that employers typically would incur to comply with this requirement. Stakeholders raised concerns about the compliance burden of this provision when conducting routine inspections on roofs. These stakeholders included the Property Casualty Insurers Association of America (Ex. 98), the Massachusetts Institute of Technology (MIT; Ex. 156), the National Roofing Contractors Association (NRCA; Ex. 197), and the U.S. Chamber of Commerce (Ex. 202). MIT's comments, presented below, are typical of these responses:

Under Subpart D—Walking-Working Surfaces, Section 1910.21(a) reads as follows: (a) Scope and application. This subpart applies to all general industry workplaces. It covers all walking-working surfaces unless specifically excluded by individual sections of this subpart. Following paragraph (a), MIT recommends adding the following narrow exception: “Exception: The provisions of this subpart do not apply when employees are making routine inspections, investigations, or assessments of workplace conditions.” Reason for comment: Periodic routine inspections, investigations, and assessments should be allowed on flat roof tops without installing guard rails, designated areas, or fall restraint/arrest systems. Employees engaged in routine inspections, investigations, and assessments of workplace conditions are exposed to fall hazards for very short durations, if at all, since they most likely would be able to accomplish their work without going near the danger zone. Requiring the installation of fall protection systems under such circumstances would expose the employee who installs those systems to falling hazards for a longer time than the person performing an inspection or similar work. As a result, the Proposed Rule could potentially create a greater hazard, rather than reducing a hazard. As stated above, the fall protection exemption anticipates that inspectors likely would be able to accomplish their work without going near the danger zone; yet installing such protections for a short time period would be

¹³¹ In the proposal, these two provisions are § 1910.27(b)(2)(x) and (xi).

expensive and time-consuming. If the exception is not included, the Proposed Rule would have a significant impact on EHS personnel checking monitors, researchers inspecting research equipment on roofs, facilities operations investigating roof drains, facilities operations assessments prior to beginning project work, and other similarly-situated employees who regularly conduct such inspections. In addition, individuals who conduct these types of inspections are trained to be very focused on their footing, ever alert, and aware of the hazards associated with falling. Therefore, employees who inspect, investigate, or assess workplace conditions will be more aware of their proximity to an unprotected edge. This proposed exception would be in line with the existing OSHA Construction Standard, 29 CFR 1926.500(a)(1). (Ex. 156.)

OSHA notes that final § 1910.28(a)(2)(ii) provides an exemption stating that when employees are making an inspection, investigation, or assessment of workplace conditions prior to the starting work or after completing all work, the employer does not have to provide fall protection unless fall protection systems or equipment meeting the requirements of § 1910.29 have been installed and are available for workers to use for pre-work and post-work inspections, investigations, or assessments.

§ 1910.28(b)(1). Under this final provision, if a walking-working surface (vertical or horizontal) has an unprotected side or edge that is four feet or more above a lower level, an employer must protect employees from falling by using a guardrail system, safety net system, or personal fall protection system. If the work is on residential roofs and the employer demonstrates that it is infeasible or creates a greater hazard to use a guardrail system, safety net system, or personal fall protection system, then the employer must develop a fall protection plan that meets the requirements of 29 CFR 1926.502(k) and training that meets the requirements of 29 CFR 1926.503(a) and (c). In the existing rule, employers must implement fall protection under the following provisions when the fall hazard is four or more feet:

- § 1910.23(b): Wall openings;
- § 1910.23(c)(1): Open-sided floors or platforms; and
- § 1910.23(c)(2): The open sides of any runway.

Thus, there is no change in the height requirement for fall protection between the existing and final rules. OSHA believes that the language and organization for the final rule is less complex than for the existing rule and provides additional flexibility in the methods used for fall protection. The final rule also allows for exceptional

conditions. For example, if it is not feasible or creates a greater hazard to install guardrails or other fall protection systems on a residential roof, then the employer does not have to install these systems and must instead develop and implement the requisite fall protection plan, including implementing other control measures to eliminate or reduce fall hazards for workers, and training. As discussed below under “Cost estimates,” OSHA anticipates that the costs for fall protection plans will not exceed the costs for guardrails and fall protection systems and, as demonstrated in employer response to the Construction standard (29 CFR 1926.502(k); 29 CFR 1926.503(a) and (c)), those compliance costs are economically feasible.

Comments to the proposal informed OSHA that chimney cleaning exposes workers to fall hazards resulting from work on residential roofs, and that protection from these fall hazards would require additional control measures. OSHA’s analysis of the compliance costs for chimney cleaning, one industry among several industries found in NAICS 56179, Other Services to Buildings and Dwellings, appears below under “Cost estimates.”

§ 1910.28(b)(2). This final provision requires fall protection in hoist areas when the fall hazard is four feet or greater, and also clarifies the requirements for hoist areas found in existing § 1910.23(b)(1) and (c)(1). Therefore, OSHA assigned no costs to this paragraph in either the PEA or in this FEA.

§ 1910.28(b)(3). The existing rule requires guarding every hole and skylight floor opening. This final provision specifies that employers must use fall protection when an employee might fall more than four feet through a hole. Thus, the new language harmonizes the fall protection requirement for holes with the requirements for unprotected sides and edges and hoist areas. The new language also permits employers to meet the requirement using covers, guardrail systems, travel restraint systems, or personal fall arrest systems.

The final revision to § 1910.28(b)(3) also provides protection for stairway floor holes, ladderway floor holes, and hatchways and chute-floor holes, and updates existing § 1910.23(a) by incorporating the best practices found in industry consensus standards (notably ANSI/ASSE A1264.1–2007). This subparagraph also clarifies application of the provision (*e.g.*, provides an exception for stairways used less than once per day). Furthermore, employers must construct guardrail systems to

protect holes in accordance with final § 1910.29, Fall protection criteria. OSHA noted in the PEA that these requirements have been part of an OSHA standard or industry consensus standards for at least 15 years and, therefore, the incremental cost burden to employers would likely be minimal. OSHA could identify no data in the record that contradicted its preliminary finding of minimal cost impact and, therefore, carried the minimal impact estimate forward in this FEA.

§ 1910.28(b)(4). This final provision requires guardrails or handrails on dockboards to protect an employee from falls of four feet or more. There is an exception for cases when employers use dockboards exclusively for material handling operations performed with motorized equipment. In these cases, neither guardrails nor handrails are necessary if the fall hazard is 10 feet or less and employees received the training specified by § 1910.30. OSHA discusses the costs for installing handrail or guardrail systems for dockboards later in this subsection, and assigned the training costs to § 1910.30 (see “Cost estimates” below).

§ 1910.28(b)(6). The existing rule § 1910.23(c)(3) requires a standard railing and toe board for walking-working surfaces above dangerous equipment. This final provision bases the required controls on the potential fall distance. For potential falls of less than four feet onto or into dangerous equipment, the employer can cover or guard the dangerous equipment to eliminate the hazard. For potential falls of four feet or more, the employer must use guardrail systems, safety net systems, travel restraint systems, or personal fall arrest systems to protect employees from the fall hazard. For both the PEA and this FEA, OSHA assumed that employers already implemented the required controls under the existing standard using the least-cost method; therefore, OSHA assigned no costs to this paragraph in either the PEA or this FEA.

§ 1910.28(b)(7). For openings, the final standard limits the need for fall protection to cases for which the inside bottom edge of the opening is less than 39 inches above a walking-working surface and the bottom edge of the outside of the opening is four feet (1.2 m) or more above a lower level. The employer can use a guardrail system, a safety net system, a travel restraint system, or a personal fall arrest system to meet this requirement. In the PEA, OSHA stated that it believed that current industry practice was to protect employees exposed to openings; therefore, the Agency estimated no costs

for this paragraph in the PEA. OSHA received no comments in the record that contradicted this preliminary assessment and, therefore, assigned no costs to paragraph (b)(7) in this FEA.

§ 1910.28(b)(8). Existing § 1910.21(a)(2) classified pits, in general, as floor openings. In this final provision, pits that are 4 feet and less than 10 feet in depth used for repair, service, or assembly operations need not have a fall protection system provided employers demarcate, with floor markings, warning lines, stanchions, or some combination thereof, a (minimum) 6-foot perimeter around the pit, limit access to that demarcated area to trained and authorized employees, and post readily visible caution signs. In the PEA, OSHA did not assign incremental costs to paragraph (b)(8) because an employer would only incur costs for caution signs and floor markings if they were less expensive than the fall protection system required under the existing standard. In addition, existing § 1910.145 already requires an employer to post caution signs where needed, and existing § 1910.144 specifies the content of the signs. OSHA assumed that most employers have signs and marking materials readily available and, therefore, assigned no incremental costs to this paragraph in the PEA. There was no evidence submitted to the record to justify revising this preliminary assessment; therefore, OSHA in this FEA estimates that any additional compliance costs associated with this paragraph will be minimal.

The final rule provides more than one method to comply with § 1910.28(b)(8). That is, an employer may use a conventional fall protection system or implement specific safe work practices (*i.e.*, marking, stanchions, posting, and limiting access). When the alternative method—the use of safe work practices—is less expensive than the method specified in the existing rule (guardrails), an employer likely would incur lower costs to comply with the paragraph. As stated in the PEA, OSHA concluded that the new provision may reduce costs for some employers; however, OSHA did not quantify the cost savings in the preliminary analysis, nor did it do so in this final analysis.

§ 1910.28(b)(9). The existing regulatory text specifies landing platforms, cages, wells, or ladder safety devices as means of providing fall protection for fixed ladders. The 1990 proposal for subpart D permitted some workers to climb fixed ladders without the use of ladder safety devices, cages, or wells if they were qualified climbers and met other, specified conditions. In particular, employers could use

qualified climbers to climb fixed ladders only if they did so no more than twice a year and it would be a greater hazard to the employee to install the fall protection system than to climb the ladder without fall protection (which OSHA believed rarely occurs).

In paragraph (b)(9) and elsewhere in the final standard, OSHA no longer permits employers to use qualified climbers beginning two years after publication of the final rule. In addition, after two years employers must equip new fixed ladders and replacement ladders and ladder sections with ladder safety systems or personal fall arrest systems. However, employers still can meet the fall protection requirement for existing fixed ladders extending more than 24 feet above a lower level by using cages, wells, personal fall arrest systems, and ladder safety systems for 20 years after publication of the final rule; after 20 years, employers must use either personal fall arrest systems or ladder safety systems for fixed ladders. For this FEA, OSHA assigned costs for using ladder safety systems on fixed ladders. OSHA's describes its analysis of costs for fall protection on fixed ladders below in "Cost estimates."

§ 1910.28(b)(10). These final paragraphs address fall hazards in outdoor advertising, also known as billboards. Existing subpart D has no requirements specific to billboards. However, for analytical purposes, the existing fixed ladder requirements cover the fixed ladder portion of a billboard. Existing § 1910.27(d)(1) requires cages or wells for ladders more than 20 feet in length. In the PEA, OSHA assumed that under proposed § 1910.28(b)(10)(i), an employee climbing the fixed ladder portion of a billboard up to 50 feet in length would need to use either a body belt or a body harness with an appropriate 18-inch rest lanyard to tie off to the fixed ladder, and that these additional options, when not already deployed, would be less expensive than cages or wells. Further, proposed § 1910.28(b)(10)(iv) required employers to properly maintain and use any ladder safety system installed on fixed ladders; according to ERG, this requirement is consistent with widespread industry practice (ERG, 2007). Thus, in the PEA, OSHA assigned no incremental compliance costs to these paragraphs. However, OSHA received a comment from the outdoor advertising industry in response to the proposal stating that ladder safety systems are not in widespread use for the initial 50-foot climb (or 65 feet from grade) on fixed ladders connected to billboards (see Exs. 329 (1/18/2011), pp. 143–146; 359, pp.7–8). Therefore, OSHA revised its

preliminary analysis in this FEA to indicate that a significant percentage of outdoor advertising employers will need to install ladder safety systems on fixed ladders. OSHA presents its estimate of the costs for those systems below in "Cost estimates."

Final § 1910.28(b)(10)(ii)(A) requires employees in outdoor advertising who climb a fixed ladder be qualified climbers as specified in § 1910.29(h) when the fixed ladder does not come equipped with a cage, well, personal fall arrest system, or a ladder safety system. Therefore, OSHA assigned the costs for this paragraph to § 1910.29(h). In doing so, the Agency conservatively assumed in both the PEA and in this FEA that all employees in NAICS 5418 (Advertising and Related Services) who climb fixed ladders will receive training as qualified climbers (see the discussion for § 1910.29(h) below). OSHA notes that the provision for qualified climbers in outdoor advertising will expire two years after publication of the final rule, at which time employers must use other means and methods of fall protection. The Agency assigned the costs of fall protection for these workers after the second year as initial and ongoing costs (see the discussion below under "Cost estimates)."

Final § 1910.28(b)(10)(ii)(B) requires that qualified climbers in outdoor advertising wear a body harness equipped with an 18-inch (46 cm) rest lanyard. Both the proposed rule at paragraph (b)(10)(i) and OSHA's outdoor advertising directive contain a similar requirement. The lanyard allows workers to tie off to the fixed ladder and rest during the climb. Proposed paragraph (b)(10)(i) and outdoor advertising directive both include a requirement permitting employers to provide, and allow workers to use, a body harness or body belt. However, the final rule does not permit the use of body belts as a part of a personal fall arrest system, thus OSHA deleted body belts from final § 1910.28(b)(10)(ii)(B). This also makes the final provision consistent with OSHA's construction industry rule, which does not allow body belts to be used for personal fall arrest (§ 1926.502(d)).

According to comment from the Outdoor Advertising Association of America (OAAA), OAAA's training program emphasizes "the duty to provide fall protection for employees working above 4–6 feet including equipment such as harnesses, lanyards and any supplemental PPE uses." (Ex. 359) Therefore, because the use of harnesses and lanyards is central to the training program of the leading outdoor advertising industry association, OSHA

anticipates that there will be no additional costs associated with the requirement in the final standard that qualified climbers be outfitted with full body harnesses. Proposed

§ 1910.28(b)(10)(vi), now codified as final § 1910.28(b)(10)(ii)(C), specifies that the employee is to have both hands free of tools and material while climbing up or down the ladder. In the PEA, OSHA assigned a cost to this paragraph; in this FEA, the Agency discusses these costs below under “Cost estimates.”

Under final § 1910.28(b)(10)(ii)(D), climbers must use an appropriate fall protection system after they reach their work positions. OSHA attributed the cost of these systems to the existing standard for fixed ladders. Thus, the Agency estimated no additional costs for equipment required by this provision in either the PEA or in this FEA.

Proposed § 1910.28(b)(10)(iii) required that employers follow inspection procedures for ladder safety systems. Final § 1910.29(i) now delineates the inspection procedures identified in the proposed requirement. OSHA did not specify in the proposed rule the frequency of inspection, but in the PEA assumed that inspections would occur prior to each use. OSHA assigned costs to this paragraph in the PEA, and discusses these costs below under “Cost estimates” in this FEA.

Final paragraph (b)(11) requires that employers protect workers from falling off stairway landings and the exposed sides of all stairways. Stairways, as defined in the final rule in § 1910.21(b)), includes standard stairs, ship stairs, spiral stairs, and alternating tread-type stairs. As noted earlier in the summary and explanation of the final standard, final paragraph (b)(11)(i), like the proposal, requires that employers ensure each worker exposed to an unprotected side or edge of a stairway landing that is four feet or more above a lower level is protected by a guardrail or stair rail system. The final requirement is consistent with the requirements for stairway landings specified by the existing general industry standard in § 1910.24(h) and the construction standard in § 1926.1052(c)(12). The final provision is also consistent with A1264.1–2007 (Section 7.1), NFPA 101–2012 (Sections 7.1.8 and 7.2.2.4.5), and ICC IBC–2012 (Section 1013.2), except that NFPA and IBC require guards on open-sided walking surfaces that are located more than 30 inches above the floor or grade below.

Final paragraph (b)(11)(ii), consistent with existing § 1910.23(d)(1) and proposed paragraph (b)(11)(ii), requires

that employers ensure each flight of stairs having at least three treads and at least four risers is equipped with a stair rail system and handrails as specified in Table D–2.

Final paragraph (b)(11)(iii), like the proposal, requires that employers ensure ship stairs and alternating tread-type stairs are equipped with handrails on both sides. Both of those types of stairs have slopes that are 50 to 70 degrees from the horizontal, and OSHA believes that workers need handrails on both sides to safely climb those stairs. This requirement is consistent with ICC IBC–2012 (Section 1009.15) and NFPA 101–2012 (Section 7.2.11.2).

In the PEA, OSHA recognized that compliance with existing consensus standards for stairways and stairway landings will eliminate much of the employee exposure to fall hazards addressed by proposed § 1910.28(b)(11). Therefore, the Agency estimated no costs for this paragraph in the PEA. OSHA received no comments in the record that contradicted this preliminary assessment. Because as shown above in Table V–16, updated versions of the same consensus standards for stairways apply to the final standard, OSHA assigned no costs to paragraph (b)(11) in this FEA.

§ 1910.28(b)(12). Final § 1910.28(b)(12)(i), which addresses the duty to provide fall protection for employees on scaffolds, refers to the construction standards at 29 CFR part 1926, subpart L (Scaffolds), thereby avoiding any inconsistencies between the general industry and construction standards. Fall protection on scaffolds in the construction standards generally follows consensus standards; thus, in the PEA, based on the estimated high level of current compliance with the construction standards or consensus standards, OSHA assigned no costs to this paragraph, and retained that cost estimate for this FEA.

Final § 1910.28(b)(12)(ii) requires that employers ensure that each employee using a rope descent system more than four feet (1.2 m) above is protected from falling by a lower level using a personal fall arrest system. Such systems must meet the requirements of 29 CFR part 1910, subpart I. OSHA addresses the costs associated with rope descent systems in “Cost estimation” below as part of the discussion of § 1910.27, Scaffolds and rope descent systems.

§ 1910.28(b)(13) and (14). These two paragraphs are new to final subpart D and introduce additional compliance costs for employers specializing in, respectively, rooftop services (paragraph (b)(13)) and work on platforms and other elevated surfaces in animal

slaughtering and animal processing plants (paragraph (b)(14)). Discussion of these costs appears in the next subsection, “Cost estimates.”

§ 1910.28(b)(15). OSHA proposed this paragraph covering walking-working surfaces not otherwise addressed by the standard to clarify existing § 1910.23(c)(3), which requires a railing and toeboard for these types of surfaces. In the final rule, the revised language restricts the requirement to working surfaces four feet or more above a lower level, and permits the employer to comply with the paragraph by using a guardrail, safety net system, travel restraint system, or personal fall arrest system. Assuming that employers will choose the least-cost compliance option and that current industry use of conventional fall protection is widespread, OSHA in the PEA assigned costs to one surface, stepbolts, that appeared to be newly affected. OSHA determined that this requirement for protection on stepbolts will primarily affect establishments in NAICS 51, Information, and NAICS 7113, Promoters of performing arts, sports, and similar events, and that the preferred fall protection will be ladder safety systems. In the next subsection, “Cost estimates”, OSHA discusses its final analysis of costs for this paragraph.

§ 1910.28(c). Final paragraph (c) requires that employers protect workers from being hit by falling objects, such as objects falling through holes or off the sides or edges of walking-working surfaces onto workers below. In addition, final paragraph (c) requires that employers protect workers using one or more of the following measures:

- Erecting toeboards, screens, or guardrail systems to prevent objects from falling to a lower level (final paragraph (c)(1));
- Erecting canopy structures and keeping potential falling objects far enough from an edge or opening to prevent them from falling to a lower level (final paragraph (c)(2)); or
- Barricading the area into which objects could fall, prohibiting workers from entering the barricaded area, and keeping objects far enough from the edge or opening to prevent them from falling to the lower level (final paragraph (c)(3)).

Final paragraph (c) simplifies the final rule by consolidating into a single paragraph all of the provisions that address falling objects found in the existing standard at § 1910.23(b)(5) and (c)(1) and the proposed rule at paragraphs (b)(3)(iii), (b)(5)(i), (b)(14)(ii)). The final rule is consistent with the proposal and patterned on the construction standard (§ 1926.501(c)).

Therefore, because the final standard introduces no additional burden on employers beyond existing requirements, and because there were no comments in the record suggesting that additional economic impacts would result, OSHA expects that final paragraph (c) will impose no new costs.

Fall Protection Systems and Falling Object Protection—Criteria and Practices (§ 1910.29)

Final § 1910.29, like the proposed rule, establishes system criteria and work practice requirements for fall protection systems and falling object protection specified by final § 1910.28, Duty to have fall protection and falling object protection, and § 1910.140, Personal fall protection equipment.

Final § 1910.29 requires that employers ensure the fall protection system and falling object protection they select meets the specified criteria and practice provisions. In general, OSHA patterned the system criteria and work practice requirements in final § 1910.29 to be consistent with its construction standards (§§ 1926.502 and 1926.1053). As mentioned in the preamble to final § 1910.28 and § 1910.29, many commenters supported making the general industry fall and falling object protection requirements consistent with those in the construction industry (*e.g.*, Exs. 124; 155; 194).

Final § 1910.29 reorganizes the existing rule so that the format of the final rule is consistent with the format in the construction fall protection standard at § 1926.502 and also draws provisions from, and is consistent with, national consensus standards addressing personal fall protection systems and falling object protection, including:

- ANSI/ASC A14.3–2008: American National Standards for Ladders—Fixed (A14.3–2008) (Ex. 8);
- ANSI/ASSE A1264.1–2007, Safety Requirements for Workplace Walking/ Working Surfaces and Their Access; Workplace, Floor, Wall and Roof Openings; Stairs and Guardrails Systems (ANSI/ASSE A1264.1–2007)(Ex. 13); and
- ANSI/ASSE A10.18–2012, Safety Requirements for Temporary Roof and Floor Holes, Wall Openings, Stairways, and Other Unprotected Edges in Construction and Demolition Operations (ANSI/ASSE A10.18–2012) (Ex. 388).

Final paragraph (b) contains system requirements employers must follow to ensure guardrail systems they use will protect workers from falling to lower levels. In developing final paragraph (b), OSHA carried forward, with some

revision, many of the requirements from the existing rule (*e.g.*, existing § 1910.23), and drew the requirements from the construction fall protection standard at § 1926.502(b).

OSHA analyzed the potential economic impacts of final § 1910.29(b) and anticipates that only paragraphs (b)(13) and (15) could potentially impose significant cost impacts, while the existence of the consensus standards listed above and other factors affecting current practice will result in no costs for all other paragraphs in § 1910.29(b). The Agency's review of the impacts associated with paragraphs (b)(13) and (15) is given immediately below.

§ 1910.29(b)(13). This final paragraph revises a related provision in the proposed standard by specifying that guardrail systems used around points of access (*e.g.*, ladderways) must have a self-closing gate that slides or swings away from the hole, with the gate constructed with a top rail, midrail, and latch or, alternatively, are offset to prevent a worker from walking or falling into the hole.

In two separate comments, Intrepid Industries, Inc. (Intrepid), recommended that OSHA clarify the proposed requirement by recognizing recent technological developments in ladderway gates. Intrepid noted in its comments that when OSHA published the 1990 proposal, multiple horizontal rails were “‘foreign’ to industry,” that since publication of the 1990 proposal, “a majority of protection devices have both a top rail and a mid rail similar to that of the guardrail . . . ,” and that such gates are equivalent in strength and design to guardrail systems and are widely available throughout industry (Exs. 68; 366). Therefore, having adopted Intrepid's recommended clarification in the final rule, OSHA estimates that few affected employers will need to replace current ladderway gates, resulting in a negligible cost burden for employers. Accordingly, as in the PEA, OSHA did not assign any costs to this provision.

§ 1910.29(b)(15). This final paragraph, as did the proposal, requires that employers inspect manila, plastic, or synthetic rope used for top rails or midrails as frequently as necessary to ensure that it meets the specified strength requirements. OSHA addresses the inspection costs for this final paragraph below in “Cost estimates.”

§ 1910.29(c). Both the proposed and final paragraphs require that employers ensure safety net systems meet the requirements in the construction standards at 29 CFR part 1926, subpart M, thus avoiding any inconsistencies between general industry and

construction standards. Given that the safety net system requirements in the construction standards follow current consensus standards, OSHA in the PEA estimated that this requirement had no incremental costs. OSHA received no comments to the proposal addressing this analysis and, therefore, attributed no costs to final § 1910.29(c) in this FEA.

§ 1910.29(h). This final paragraph outdoor advertising operations, and sets forth the criteria for the use of qualified climbers, which it limits to these operations. In the PEA, OSHA modeled the costs to train and, as necessary, retrain qualified climbers. That is, OSHA assumed that qualified climbers required training beyond that now required for fixed ladders and, furthermore, OSHA believed that employers would incur additional costs associated with the requirement that the employer observe the performance to ensure the qualified climber has the skills necessary to perform the climb safely.

The final standard permits the use of qualified climbers up to two years after publication of the rule, after which outdoor advertising employers must protect employees engaged in outdoor advertising from fall hazards in accordance with provisions of § 1910.28. Therefore, although OSHA's estimate of costs associated with the criteria enumerated in § 1910.29(h) would not apply two years after publication of the final rule, OSHA retained those costs in this final analysis to account for any training costs connected with transitioning to the use of ladder safety systems or other fall protection measures on fixed ladders. OSHA discusses the cost estimates for final § 1910.29(h) below under “Cost estimates.”

The other requirements in final § 1910.29, include the requirements found in final paragraphs (d) Designated areas, (e) Covers, and (f) Handrail and stair rail systems, (g) Cages, wells, and platforms used with fixed ladders, (i) Ladder safety systems, (j) Personal fall protection systems, (k) Protection from falling objects, and (l) Grab bars (specified as “Grab handles” in the NPRM). OSHA in the PEA noted that there already is significant, widespread compliance with the proposed requirements among general industry employers, resulting in the proposed requirements imposing minimal incremental cost burden on employers. OSHA requested feedback from the public on this analysis, but received no comments to this request. Therefore, in this FEA, OSHA assigned no costs to paragraphs (d) Designated areas, (e)

Covers, (f) Handrail and stair rail systems, (g) Cages, wells, and platforms used with fixed ladders, (i) Ladder safety systems, (j) Personal fall protection systems, (k) Protection from falling objects, and (l) Grab bars.

Training Requirements (§ 1910.30)

This new section requires that employers in general industry train their employees regarding fall and equipment hazards, and retrain them when necessary. In the PEA, OSHA assumed that an employer that trains employees in compliance with § 1910.30 would choose to maintain records of the training, and the cost estimates in the PEA took account of this time burden on employers. The training costs estimated for proposed § 1910.30 included requirements from other proposed paragraphs that specify that the employer must conduct the training in accordance with proposed § 1910.30 (see Table V–18 for examples). OSHA discusses these costs in more detail below under “Cost estimates”; in this analysis, incremental training costs apply only to the percentage of establishments that do not already provide regular safety training.

5. Cost Impacts for Final Subpart I (Personal Protective Equipment)

In the NPRM, OSHA proposed to add a new section, § 1910.140, to 29 CFR part 1910, subpart I, to address personal fall protection equipment. The proposed text for § 1910.140 added specific design and performance requirements for personal fall protection systems to existing subpart I. In addition, the proposed standard required that the provisions for hazard assessment found in existing § 1910.132 apply as well to personal fall protection systems.

The text of the final standard is virtually identical to that of the proposed rule, and although a number of commenters raised concerns about the technical specifications and criteria that would apply to personal fall protection systems, OSHA received few, if any, comments directly addressing the PEA. The discussion below describes OSHA’s general treatment of costs for subpart I; the next subsection, “Cost estimates,” provides additional details on the specific method for estimating costs.

§ 1910.132(g). Existing § 1910.132(g) lists the personal protective equipment standards under 29 CFR part 1910, subpart I, that are subject to the requirements specified in existing § 1910.132(d) and (f). Paragraph (d) of § 1910.132 requires employers to assess the workplace to identify any potential hazards and the need for PPE, while

§ 1910.132(f) requires employers to train employers, at specified times, on the application limits of the equipment; proper hook-up, anchoring, and tie-off techniques; methods of care, use, and disposal; and proper methods of equipment inspection and storage. Final § 1910.132(g) adds the personal fall protection equipment regulated under § 1910.140 to the list of covered personal protective equipment. In the PEA, OSHA identified significant costs in connection with the proposed requirement; the Agency discusses the costs associated with this final requirement below under “Cost estimates” (for §§ 1910.140, Personal fall protection systems, and 1910.30, Training).

§ 1910.140(c)(18). 29 CFR 1910.140 is a new section that OSHA is adding to subpart I Personal Protective Equipment (PPE) (29 CFR part 1910, subpart I) to address personal fall protection systems, which include personal fall arrest, travel restraint, and positioning systems. The new section establishes requirements for the design, performance, use, and inspection of personal fall protection systems and system components (e.g., body harnesses, lifelines, lanyards, anchorages).

Similar to the final rule revising 29 CFR part 1910, subpart D, final § 1910.140, when appropriate, also draws from national consensus standards addressing personal fall protection systems, details of which are provided in Section IV.B. of this document. Therefore, with the exception of one paragraph in § 1910.140, paragraph (c)(18), OSHA in the PEA estimated that current industry practice is widespread, and there were no comments objecting to that preliminary estimate. Final § 1910.140(c)(18) requires that employers inspect personal fall protection systems prior to the initial use during each workshift. In the PEA, OSHA identified significant costs in connection with the proposed requirement; the Agency discusses costs for this final paragraph below under “Cost estimates.”

6. Cost Estimates

This subsection presents OSHA’s detailed estimates of the costs associated with the final rule, provision by provision. These compliance costs represent the incremental burden incurred by employers beyond the current baseline of fall-related safety expenditures. OSHA did not estimate potential cost savings to industry from increased flexibility in meeting specific requirements, such as using personal fall protection systems rather than the

currently mandated handrail/guardrail systems, even if some of the new requirements might be safer than the currently mandated requirements.¹³²

For a number of cost categories, there were no public comments on the PEA. For those cases, OSHA updated the applied unit wage and the numbers of affected employers and employees to reflect the revised profile, but retained the cost methodology used in the PEA. For provisions in the final standard for which OSHA adjusted the preliminary cost estimate, the Agency describes the form of the cost revision and the public comments that lead to the final cost estimate.

a. Estimated Compliance Costs by Provision in the Final Standard for Subpart D

Labor costs associated with compliance with the final standard generally involve additional employer and supervisor time for training and inspection. OSHA took the number of establishments and employees from *Statistics of U.S. Businesses: 2007*. The Agency based the number of employees covered by subparts D and I on the share of employees working in building and grounds; construction;¹³³ installation, maintenance, and repair; production; and material-moving occupations reported by the Bureau of Labor Statistics, *Occupational Employment Statistics* (BLS, 2007). See section C above in this FEA for additional industry-profile information.

OSHA based employee and supervisor wages (see Table V–5) on data reported by the Bureau of Labor Statistics through their *Occupational Employment Statistics* program (BLS, 2010). OSHA adjusted wages to include the cost of benefits, and determined estimated benefits from data provided from the Bureau of Labor Statistics, *Employer Costs for Employee Compensation—*

¹³² The Agency assumed that the new requirements are at least as effective in employee protection as the requirements provided by the existing requirements.

¹³³ As noted earlier in this FEA, production workers include workers in building and grounds; construction; installation, maintenance, and repair; production; and material-moving occupations. It is possible that employees in construction and related occupations, even though not employed by establishments in construction industries, might perform work regulated by OSHA under its construction standards in 29 CFR part 1926. Therefore, the employers of these workers, depending on the type of work performed, also may have to meet the requirements for fall protection and walking-working surfaces specified in the construction standards. For the purpose of estimating costs, however, OSHA assumed that the general industry standards cover these employees.

June 2011 (released September 2011).¹³⁴ The Agency based current compliance rates on OSHA inspection statistics for fiscal year 2005 (see Table V-15); it

determined the fraction of businesses that already provide regular safety training from information in the *National Occupational Exposure Survey*

conducted by the National Institute for Occupational Safety and Health (NIOSH, 1988). See Table V-20, below.

Table V-20
Fraction of Businesses Providing Regular Safety Training

NAICS	Industry	Fraction Providing Regular Safety Training
11	Agriculture, Forestry, Fishing, and Hunting	.796
21	Mining (2111 Oil and Gas Extraction)	.751
22	Utilities	.890

Table V-20
Fraction of Businesses Providing Regular Safety Training

NAICS	Industry	Fraction Providing Regular Safety Training
31-33	Manufacturing	.855
42	Wholesale Trade	.668
44-45	Retail Trade	.668
48-49	Transportation	.890
51	Information	.664
52	Finance and Insurance	.664
53	Real Estate	.664
54	Professional, Scientific, and Technical Services	.664
55	Management	.664
56	Administrative and Support, Waste Management and Remediation Services	.664
61	Educational Services	.83
62	Health Care	.957
71	Arts, Entertainment, and Recreation	.664
72	Accommodation and Food Services	.664
81	Other Services	.664

Source: ERG, 2007, based on NIOSH, 1988.

General Requirements (§ 1910.22)

Final § 1910.22 contains three paragraphs with new requirements:

- § 1910.22(d)(1): Perform regular and periodic inspection, and maintenance, of walking-working surfaces;
- § 1910.22(d)(2): Correct and repair hazardous conditions on walking-

working surfaces, and guard unsafe conditions until corrected or repaired; and

- § 1910.22(d)(3): Have a qualified person perform or supervise any

¹³⁴ Throughout the discussion below, wages that include benefits are also referred to as "loaded" wages.

correction or repair that involves the structural integrity of a walking-working surface.

There were no public comments that addressed OSHA's preliminary approach to estimating costs the costs for these paragraphs. For the final standard, OSHA revised all three provisions from the proposed language for clarification.

For the purpose of estimating costs for § 1910.22(d)(1), OSHA in the PEA assumed that a significant percentage of facilities already include regular and periodic inspections of walking-working surfaces. OSHA used the non-compliance rates for floor-guarding in proposed § 1910.23 (which has the highest non-compliance rates, see Table V-15) to estimate the number of establishments that need to perform regular and periodic inspections of walking-working surfaces. OSHA assumed that a supervisor would spend 15 minutes every quarter performing the inspection, for a total of 1 hour per year. Based on these unit costs, OSHA preliminarily estimated that the total annual inspection cost would be \$15.3 million.

Relative to the existing and proposed standards, the final standard provides more specificity in the types of hazards for which employers will be inspecting walking-working surfaces (namely, protruding or sharp objects, loose boards, corrosion, leaks and spills). Included among the inspected surfaces will be residential roofs (addressed in § 1910.28(b)(1)), low-slope roofs (§ 1910.28(b)(13)), and slaughtering

facility platforms (§ 1910.28(b)(14)), surfaces whose inclusion in the scope of the proposed standard is recognized by OSHA in this final notice. As a result of further analysis of these affected surfaces, OSHA believes that regular and periodic inspections will be more extensive than determined in the PEA. For this final analysis, OSHA raised the quarterly inspection time from 15 minutes to 30 minutes. Therefore, OSHA estimated the final cost for paragraph § 1910.22(d)(1) to be \$32.8 million.¹³⁵

For estimating the costs of § 1910.22(d)(2), OSHA in the PEA projected that within a year, 10 percent of affected establishments would identify an unsafe condition, and that it takes an employee 15 minutes to set up a guard mechanism (e.g., cones, barriers). The Agency assumed incremental material costs to be negligible since it is likely that most employers currently stock guard equipment but only occasionally deploy it. Estimated compliance costs for this provision were \$0.23 million in the PEA and are \$0.25 million in this FEA.¹³⁶

¹³⁵ For timber tract operations (NAICS 1131), costs are estimated by multiplying together 450 establishments (see Table V-1), 9.6 percent noncompliance rate for existing floor guarding requirements (see Table V-15), two hours per supervisor, and a \$26.10 hourly loaded wage (see Table V-5), yielding a result of \$2,263. Analogous calculations are performed for each industry and summed to produce the total of \$32.8 million.

¹³⁶ For example, OSHA estimated the costs to correct unsafe conditions for timber tract operations (NAICS 1131) in the following way. Total guarding cost = no. of affected establishments * (1 - current

compliance rate) * percent with an unsafe condition * time to set up guarding * employee hourly loaded wage = 450 establishments (1 - 90.4 percent) * 10 percent * 0.25 hours * \$19.99 = \$22. Analogous calculations are performed for each industry and summed to produce the total of \$0.25 million.

For § 1910.22(d)(3), OSHA in the PEA estimated that it takes five minutes for a supervisor or qualified person to inspect the repair of the unsafe condition. Final § 1910.22(d)(3) was revised to read that when any correction or repair involving the structural integrity of the walking-working surface is conducted, a qualified person must perform or supervise the correction or repair. Applying the five-minute time unit across all affected employers, OSHA preliminarily estimated that the costs for a supervisor or qualified person to inspect repairs would total \$0.13 million, and, applying the five-minute unit for this FEA, determined that final costs will be slightly higher, at \$0.14 million for performance or supervision of the correction or repair.

Summing costs for the three paragraphs in final § 1910.22(d) with cost impacts, the total estimated cost for compliance with § 1910.22(d) is, after rounding, \$33.2 million per year.

Ladders (§ 1910.23)

In the PEA, eight paragraphs in proposed § 1910.23 specify new training requirements for protecting employees from slip, trip, and fall hazards during operations involving ladders. Table V-21 summarizes these eight new training requirements.

compliance rate) * percent with an unsafe condition * time to set up guarding * employee hourly loaded wage = 450 establishments (1 - 90.4 percent) * 10 percent * 0.25 hours * \$19.99 = \$22. Analogous calculations are performed for each industry and summed to produce the total of \$0.25 million.

Table V-21
Training Requirements Under §1910.23 – Ladders

Paragraph	Subject
§1910.23(b)(11)	When ascending or descending a ladder, the employee must face the ladder.
§1910.23(b)(12)	Each employee must use at least one hand to grasp the ladder when progressing up and down the ladder.
§1910.23(b)(13)	Employees must not carry any object or load that could cause the employee to lose their balance and fall.
§1910.23(c)(5)	Prohibits use of portable single rail ladders.
§1910.23(c)(6)	Prohibits moving, shifting, or extending a ladder occupied by employees.
§1910.23(c)(9)	Secure and stabilize non-self-supporting ladders used on slippery surfaces.
§1910.23(c)(10)	Place the top of a non-self-supporting ladder with the two rails supported unless it is equipped with a single support attachment. [New for wood ladders.]
§1910.23(c)(11)	When using portable ladders to gain access to an upper landing surface, the ladder siderails must extend at least three feet (0.9 m) above that upper landing surface. [New for metal ladders.]
§1910.28(e)(1)(viii)	The employer must ensure that mobile ladder stands and platforms are not moved when occupied by an employee.

Source: U.S. Department of Labor, OSHA, Directorate of Standards and Guidance, Office of Regulatory Analysis-Safety.

The PEA determined that employers could address all eight of these new provisions in a single training session. In addition, OSHA determined that employers can comply with these provisions using informal training; therefore, the Agency did not include administrative costs for employers. For this FEA, OSHA added a ninth provision, § 1910.23(c)(9), addressing stabilization of ladders on slippery surfaces, to its analysis of costs, and applied the same cost modeling parameters here as it did in the PEA.

OSHA's Web site includes a resource center with a loan program for training videos (OSHA, 2012b). The index lists 12 training videos for ladders and stairways, with run times ranging from 5 to 19 minutes, for an average of 12 minutes. Accordingly, for the purposes of estimating costs for ladder safety training, OSHA in the PEA and this FEA

applied a 15-minute training period per video.

In OSHA's cost model, employers can train 10 employees per session, with one supervisor in attendance. OSHA further assumed that employers incur \$1 in materials cost for handouts for each employee trained.

Some establishments already provide regular safety training. For each affected NAICS industry, OSHA applied an estimate for the percentage of employees already providing training. OSHA's derived its industry-by-industry baseline estimate for safety training from the NIOSH *National Occupational Exposure Survey* (NOES) database (NIOSH, 1988). Although these data are over 25 years old, the NIOSH NOES survey is still the primary source for such information, and covers a broad range of industries. No comment in the record suggested that the NIOSH NOES

survey data are no longer accurate. Furthermore, OSHA believes that the proportion of employees already offered regular safety training likely increased over the past two decades; hence, the Agency most likely overestimated the training costs.

The cost to train employees at establishments that do not offer regular safety training is a one-time cost annualized over a 10-year period at a discount rate of 7 percent. Summing across all affected employers, the total first-year cost is \$11.5 million, with an annualized cost of \$1.6 million.¹³⁷

¹³⁷ For gambling industries (NAICS 7132), costs are estimated by first multiplying together 5,240 employees (see Table V-1) and the 33.6 percent rate of not yet providing training (=1-0.664 shown in Table V-20), yielding an estimate of 1,761 employees that do not yet receive training. Next, this estimate is multiplied by the sum of worker

New employees who begin affected jobs also will need training. For the purpose of estimating this cost, OSHA in the PEA assumed that training received from a prior employer was not sufficient to meet the proposed subpart D requirement. ERG's analysis of 2002

hires data collected by the Bureau of Labor Statistics (ERG, 2007) formed the basis in the PEA for OSHA's analysis of the annual costs of training employees new to the workforce; for this FEA, OSHA used 2007 BLS industry hires-rate data to correspond to the

employment levels (2007) used in the analysis. Table V-22 below summarizes these data for the NAICS codes affected by this final standard. Under these assumptions, the estimated cost is \$5.4 million per year to train new employees in ladder safety.

**Table V-22
Industry Hires Rates Applied in OSHA's Cost Analysis**

Industry	NAICS	2007 Annual Hires Rates
Mining and Logging	1133 21	45.4
Durable Goods Manufacturing	321, 327, 33	29.8
Nondurable Goods manufacturing	31, 322, 323, 324, 325, 326	36.9
Wholesale trade	42	34.9
Retail trade	44 -45	58.8
Transportation, warehousing, and utilities	22, 48-49	36.3
Information	51	31.2
Finance and Insurance	52	31.7
Real Estate and Rental and Leasing	53	47.6
Professional and Business Services	54-56	63.1
Educational Services	61	30.7
Health Care and Social Assistance	62	35.4
Arts, Entertainment, and Recreation	71	81.8
Accommodation and Food Services	72	82.8
Other services	81	41.9

Source: Bureau of Labor Statistics (BLS, 2007), Job Openings and Labor Turnover Survey (JOLTS).

In the PEA, to estimate the costs of mobile ladder stands and mobile ladder stand platforms that conform to the design requirements specified in § 1910.23(e), OSHA's cost formula included all establishments potentially covered by proposed subpart D. OSHA assumed that the typical lifetime for a ladder is five years; thus, one-fifth of the establishments would purchase a ladder meeting the design requirements each year.¹³⁸ Furthermore, OSHA assumed that a supervisor from each establishment would take five minutes

to read ladder specifications to ensure that, prior to purchase, the ladder met the requirements for that type ladder. With these assumptions, the estimated annual cost for § 1910.23(e) was \$3.8 million in the PEA; in this FEA, allowing for the increase in the number of affected establishments and updated wage rates (generally upward), annual total costs for final § 1910.23(e) are \$4.2 million.¹³⁹

Step Bolts and Manhole Steps (\$ 1910.24)

Step bolts. In estimating the cost of the step-bolt inspection requirement specified by proposed paragraph (a)(8) in the PEA, OSHA identified three types of structures requiring step bolts and pole steps:

- Utility poles;
- Communication structures; and
- Pole-mounted lights in sports and performance arenas.

Final paragraph (a)(8) requires that employers ensure step bolts are

time costs (0.25 hours times an \$18.80 hourly production worker loaded wage (see Table V-5)), materials costs (\$1 per employee) and instructor time costs (0.25 hours times a \$38.66 hourly supervisor loaded wage (see Table V-5), divided by 10 to reflect a 10-worker class size), yielding a result of \$11,736 (= \$8,274 labor cost + \$1,761 materials cost + \$1,701 instructor cost). Analogous

calculations are performed for each industry and summed to produce the total of \$11.5 million.

¹³⁸ Underlying this assumption is the likelihood that some establishments will purchase more than one ladder in a given year, or will purchase more than one ladder over the five-year span.

¹³⁹ For grantmaking and giving services (NAICS 8132), costs are estimated by first multiplying together 16,356 establishments (see Table V-1) and

the 20 percent rate applied in ladder replacement, yielding an estimate of 3,271 establishments that will be purchasing a ladder. Next, this estimate is multiplied by the sum of worker time costs (5 minutes/60 minutes = 0.083 hours times a \$29.89 hourly production supervisor loaded wage (see Table V-5)), yielding a result of \$8,147. Analogous calculations are performed for each industry and summed to produce the total of \$4.2 million.

inspected at the start of each work shift and maintained in accordance with § 1910.22. OSHA addresses the cost impacts of final paragraph (a)(8) in the following discussion.

Utility poles. According to the 2007 *Utility Data Institute Directory of Electric Power Producers and Distributors*, there are 6,297,596 miles of distribution lines in the United States (Platts, 2007).¹⁴⁰ According to ERG, the most recent mileage estimate available for overhead distribution lines was 4.1 million miles in 1996, or about two-thirds of total line miles (NCAMP, 1997). Considering the maturity of the electric-power industry in the United States, OSHA assumed that there has not been a significant increase in overhead line miles since 1996, with most new lines probably built underground. Assuming one utility pole for every 100 feet of line, OSHA estimated that there are 216,480,000 utility poles in the United States. According to a 2004 highway safety study, this estimate is 2.5 times the number of reported utility poles on highways in 1999 (NCHRP, 2004); therefore, OSHA's estimate appears to be reasonable.

OSHA assumed that employees in the affected industry group—NAICS 2211, Electric Power Generation, Transmission and Distribution—climb one percent of the poles once each year and that it takes a production worker (at an hourly wage of \$45.11, including benefits) one minute to inspect the step bolts on a pole. Therefore, the estimated annual cost in the PEA for inspecting step bolts was \$1.5 million. In the absence of any comment on the record taking exception to this analysis, in this FEA, OSHA estimated the cost for this requirement to be \$1.6 million, allowing for an increase in wages since publication of the NPRM.

Communication structures. For the PEA, ERG estimated that there are roughly 190,000 fixed-ladder structures in the communications industry (see ERG, 2007, Appendix A). This estimate encompasses communication structures with fixed ladders and step bolts. Fixed ladders, however, have an existing requirement for inspection, while step bolts do not. To narrow the estimate to fixed ladders with step bolts, ERG searched an FCC database (Antenna Structure Registration (ASR)) and determined that most communication

structures meet at least one of the following criteria:

- Height is 200 feet or higher;
- Height <199 feet if within 5 miles of an airport and fails the glide calculation (part 17 requirement); or
- Height of the extension (*e.g.*, beyond the building roof) is 20 feet or more.

ERG assumed that these structures are more likely to have fixed ladders rather than step bolts. As of May 2007, there were approximately 93,000 structures in the ASR database. Communication structures that are not in the ASR database are smaller and, thus, more likely to have step bolts. ERG calculated that the difference between the total number of structures (190,000) and the number in the ASR database (93,000) would represent the number of structures that could potentially have step bolts. Following ERG's methodology, OSHA's cost model projected that employees climb each of the 97,000 structures with step bolts once a year and that spend one minute inspecting the structure before climbing it. These unit estimates resulted in an annual cost of \$0.05 million (\$50,000) for NAICS 51 (Information) in the PEA; with 2010 loaded hourly wages ranging from \$21.64 to \$32.60 for production workers across sixteen four-digit industry codes in NAICS 51, the annual cost is approximately \$0.04 million (\$43,000) in this FEA (average wages for production workers in NAICS 51 fell from 2008 to 2010).

Sports and performance arenas. According to the 2002 census, there were 1,699 establishments in NAICS 7113, Promoters of performing arts, sports, and similar events, with facilities (Census, 2002). For the PEA, ERG was unable to estimate the number of step bolts at each facility, but instead assumed that employers spent one hour per year inspecting all step bolts at each facility (OSHA assumed that a production worker would conduct the inspection). Therefore, in the PEA, OSHA calculated that annual costs would total \$0.034 million (\$34,000) for NAICS 7113. For this FEA, annual costs for NAICS 7113 total \$0.050 million (\$50,000) after updating the number of facilities (2,613) per the 2007 Census and applying the 2010 loaded hourly wage of \$19.08 for production workers in NAICS 7113.

Summing costs for utility poles, communication structures, and sports and performance arenas, OSHA estimated in the PEA that the total annual inspection costs for step bolts would be \$1.54 million; for this FEA, total inspection costs are \$1.72 million.

In the proposal, OSHA requested, but did not receive: (1) Comment on the extent to which employers currently conduct visual inspection¹⁴¹ of step bolts in the telecommunications and electric-utility industries, and in sports and performance arenas; (2) comment on the assumptions underlying its analysis of costs; and (3) information on the potential impacts of the proposed requirements on climbing surfaces with step bolts safely. Therefore, in this FEA, OSHA adjusted the cost estimates in the PEA only to the extent that wages and the number of establishments changed since it published the PEA.

For this final economic analysis, OSHA included, within the total costs for the final standards for step bolts under final § 1910.24, the costs for repairing or replacing defective step bolts identified in inspections required by the final rule. Based on a review of OSHA 2005 inspection data for the Transportation and Utility sectors, OSHA calculated that 0.34% of inspected step bolts will be found to be out of compliance.¹⁴² Applying this step bolt failure rate to the total number of step bolts in affected NAICS industries (*see above*) yields an estimated 7,727 step bolts repaired or replaced yearly. At a unit cost of \$4.50 or \$14.75 per step bolt depending on the NAICS code¹⁴³ and an installation time of fifteen minutes, annual costs for repair or replacement of step bolts are expected to total approximately \$0.3 million. (*See Ex. [OSHA Excel Workbook], Tab annual_24_stepbolts.*)

Summing costs for inspection of step bolts and repair or replacement of defective step bolts, OSHA estimates that the costs for the provisions addressing step bolts under final § 1910.24 will total \$2.0 million.

Manhole steps. Final paragraph (b) addresses the design, capacity, and use of manhole steps. As discussed earlier,

¹⁴¹ The requirement in the proposed standard that step bolts be "visually inspected" was revised in the final standard to read that step bolts be "inspected".

¹⁴² Of 38,714 OSHA inspections in 2005, 11,469 resulted in citations, of which 1,301 were in Transportation or Utility industries. One hundred and fifty-six citations in Transportation/Utility referenced Subpart D, and of that total, 15 citations referenced 1910.24, Fixed industrial stairs, the existing standard judged by OSHA to be most closely associated with the final provision for step bolts. (*See https://www.osha.gov/dep/enforcement/enforcement_results_05.html*). Therefore, (11,469 citations/38,714 inspections) * (156 Transportation/Utility citations in Subpart D/1,301 total Transportation/Utility citations) * (15 industrial stairs citations/156 Subpart D citations) = 0.34% probability of a scaffolds citation in Transportation/Utility sector.

¹⁴³ NAICS 22: \$4.50; NAICS 51, 71: \$14.75. *See Ex. [OSHA Excel Workbook], Tab annual_24_stepbolts.*

¹⁴⁰ The final Electric Power Generation, Transmission, and Distribution; Electrical Protective Equipment standard requires that employers follow the fall protection requirements in 29 CFR part 1910, subpart I (79 FR 20315 (4/11/2014); see § 1910.269(g) in this final rule).

three requirements in final paragraph (b)(2) exceed the requirements specified in a national consensus standard, ASTM C478–13, for steps in precast concrete manhole sections:

- Manhole steps must have slip-resistant surfaces such as corrugated, knurled, or dimpled surfaces;
- Manhole steps must be constructed of, or coated with, material that protects against corrosion in an environment where corrosion may occur; and
- The design of manhole steps must prevent the employee's foot from slipping or sliding off the end of the manhole step.

OSHA expects that employers will identify any deficiencies in manhole steps through compliance with final paragraph (b)(3); that provision requires that employers ensure manhole steps are inspected at the start of the work shift, and maintained in accordance with § 1910.22. In estimating the cost of the manhole-step inspection requirement specified by proposed paragraph (b)(3) in the PEA, OSHA estimated there are between 6.6 million and 13.2 million manholes, with a mid-point estimate of 9.9 million, nearly all of which are in water, sewage, and related utilities. Of these manholes, approximately 85 percent, or 8.4 million manholes, are 20 feet or less in depth, while the remainder, 15 percent or 1.5 million manholes, are more than 20 feet in depth. In the PEA, OSHA estimated that employees would enter 10 percent of all manholes, on average, and that it would take one minute to inspect the steps prior to entering the manhole. That analysis resulted in an estimated annual cost of \$0.4 million for the industry most affected by this requirement, NAICS 2213 (Water, sewage, and other systems). After updating the wage rate for production workers in NAICS 2213, OSHA's final estimate for inspection of manhole equipment, including steps, totals \$0.5 million.

Other industries also use manholes for access, such as electric-power generation, transmission, and distribution (NAICS 2211) and natural-gas distribution (NAICS 2212). ERG, however, had no data on the number of manholes for those industry groups, and although OSHA assumed in the PEA that the costs would be proportional to the number of manholes estimated for water and sewage systems, OSHA was not able to estimate costs for NAICS 2211 and 2212. The Agency requested, but did not receive, public comment in the proposal on the impact of the inspection requirement on these and any other affected industries. Therefore, for this FEA, OSHA assumed that, for

NAICS 2211 and 2212, employers seldom encounter manholes, and that when they do encounter manholes, they routinely inspect the manhole steps to ensure that the steps meet or exceed the requirements of the final rule. Therefore, OSHA determined that, under the final standard, any incremental costs for manhole fall protection in NAICS 2211 and 2212 will not be significant.

Employers would incur costs for slip-resistant and corrosion-resistant manhole step surfaces required by proposed paragraphs (b)(2)(i) and (ii) in the future because employers would replace manholes with steps at the end of their useful life. As described above, OSHA estimates there are 9.9 million manholes, of which 85 percent are 20 feet or less in depth and 15 percent are more than 20 feet in depth. In the PEA, OSHA assumed that manholes less than or equal to 20 feet in depth used portable ladders, fixed ladders, and steps in equal shares, resulting in 2.9 million manholes with steps, while it assumed that manholes more than 20 feet in depth used fixed ladders and steps in equal shares, resulting in 0.7 million manholes with steps. This analysis, therefore, indicates that the proposed requirement would affect 3.6 million manholes. The manhole step selected from vendor lists in the PEA had a per-unit cost of \$8.50, and OSHA assumed that this price included a 10 percent premium for the steps to meet the proposed requirements (ERG, 2007).

Applying the unit values and methodological assumptions described above for this FEA, OSHA estimated annual replacement costs for steps by applying a 10 percent rate for annual entry of manholes and, of that number, applying a 10-percent rung failure rate. At the incremental cost of \$0.85 each (10 percent of \$8.50 per rung), the estimated annual replacement cost for steps is \$0.03 million (\$31,000). OSHA estimated annual replacement costs for all manhole-access equipment (including steps, but excluding manhole covers) assuming a baseline of ten percent and further assuming that employers would replace 5 percent of this equipment each year and would install steps every 16 inches. Accordingly, the estimated yearly manhole replacement cost is \$1.6 million, and combining this cost with OSHA's final estimate of costs for inspection of manhole equipment, including steps (\$0.5 million), OSHA derives a total cost of \$2.1 million for manhole fall protection under the final rule (after rounding).

For this FEA, OSHA has included the labor costs for annual replacement of

manhole steps or rungs that are judged to be out of compliance with the final standard. OSHA applied a baseline compliance rate of ten percent for affected utilities, estimated that removal of the old rung or step and replacement with a new one will involve 15 minutes of labor per rung or step (hourly loaded wage of \$30.47 for a production worker in NAICS 2213 (water, sewage utilities)), and multiplied unit labor cost times the total number of affected steps, or 1.83 million steps after adjusting for baseline.¹⁴⁴ Combining those cost factors, the Agency estimates that labor costs for removal and replacement of defective rungs or steps will total \$13.9 million.

Combining costs for inspections and repair of step bolts and manhole steps, OSHA estimates that the final costs associated with § 1910.24, Stepbolts and manhole steps, will total \$16.0 million.

Scaffolds and Rope Descent Systems (§ 1910.27)

Training. Paragraph (b)(2)(ii) of proposed § 1910.27 and paragraph (b)(2)(iii) of the final § 1910.27 specify training requirements for rope descent systems. As described earlier in this "Costs of Compliance" section, OSHA attributed costs for any training beyond what is done as a result of the 1991 OSHA memorandum on descent-control devices to final § 1910.30 (see below).

Sound anchorages. In the PEA, costs assigned to ensure sound anchorages as required by proposed § 1910.27(b)(iv) involved: (1) A qualified/competent person who would inspect the rigging and anchorages on buildings annually, and (2) a professional engineer who would certify the soundness of the rigging and anchorages every 10 years.

According to an industry expert contacted by ERG, an estimated 3.0 million window cleaning descents take place annually at 750,000 buildings in the U.S. (ERG, 2007). In the absence of comments on the PEA in the proposal, OSHA is retaining these estimates in this FEA for the inspection and certification requirements specified by final § 1910.27(b)(1)(i). Using data collected by the Department of Energy (DOE) for surveys on energy use, ERG compared this estimate with the number of commercial and residential buildings with four or more floors. The 2003

¹⁴⁴ 1.06 million steps or rungs in manholes less than 20 ft. deep (28,611 in single-rung manholes and 1,144,440 in multi-rung manholes) + 780,000 steps or rungs in manholes more than 20 ft. deep (7,425 in single-rung manholes and 853,875 in multi-rung manholes) = 2.03 million steps or rungs (100% – 10% baseline) = 1.83 million steps or rungs. See Document ID [OSHA Excel Workbook], Tab materials_24_manholes.

Commercial Buildings Energy Consumption Survey identified about 140,000 commercial buildings nationwide (DOE, 2006). The *2001 Residential Energy Consumption Survey* (RECS) identified about 2.4 million apartment buildings with 5 to 10 floors, 0.9 million apartment buildings with 11 to 20 floors, and an unspecified number of buildings with more than 20 floors (DOE, 2004). Summing the three categories of residential buildings, ERG estimated that there are approximately 3.3 million residential buildings in the U.S. with five or more floors.¹⁴⁵

OSHA assumed that each commercial building has its windows cleaned annually, thereby accounting for 140,000 of the estimated 750,000 window cleanings per year. If the 3.3 million residential buildings account for the remaining 610,000 cleanings, each of these buildings would, on average, have its windows cleaned every five to six years.

ERG's industry expert estimated that a minimum of 20 percent of the building owners complied with the anchorage-inspection requirement, and that the number was increasing. However, comments submitted to the Agency in response to the 2003 reopening were inconsistent regarding the likelihood that building owners inspect their anchorages on a periodic basis. Amodeo (2003) noted that some clients view ANSI I-14.1 as voluntary and resist having inspections. Kreidenweis (2003) commented that engineers seldom inspect anchorages.¹⁴⁶ In contrast, Lebel (2003) noted that many buildings have a roof plan and identified anchorages (*i.e.* anchorages designated for use in window cleaning), certified by a

professional engineer. Zeolla (2003) stated that most buildings that invest in anchors are inspecting them. On the basis of these comments, OSHA in the PEA estimated that 25 percent of the approximately 750,000 buildings cleaned every year undergo anchor certification on a consistent basis.

OSHA's final standard provides more detailed requirements for anchorages used with rope descent systems than the proposed standard. Final § 1910.27(b)(1)(i) states that before any rope descent system is used, the building owner must inform the employer, in writing, that the building owner has identified, tested, certified, and maintained each anchorage so it is capable of supporting at least 5,000 pounds (268 kg), in any direction, for each employee attached. The information must be based on an annual inspection by a qualified person and certification of each anchorage by a qualified person, as necessary, and at least every 10 years.

Therefore, for this FEA, OSHA revised upward its estimate of the baseline level for anchor certification. Accordingly, OSHA believes that the current baseline is at least 35 percent nationwide, and may be much higher in some markets. For example, the owner of Chicago's largest window cleaning company testified in OSHA's public hearings on the NPRM that in Chicago, 60 to 70 percent of building owners provide documentation of anchor certification (Ex. 329 (1/19/2011), p. 218). Similarly, the owner of one of Houston's leading window cleaning companies testified that every building owner that he works with provides certification of anchorages (Ex. 329 (1/19/2011), p.

310). Recognizing that in some smaller markets, anchor certification may not be as widespread or frequent as suggested by these commenters, OSHA applied a baseline level of 35 percent for anchor certification and inspection in estimating costs for this requirement in the FEA.

Therefore, if 65 percent of the approximately 750,000 buildings that have windows cleaned each year must now comply with the final inspection and certification requirement, then OSHA estimates that 487,500 buildings will require annual inspections and decennial certifications. In the PEA, OSHA further assumed that a production supervisor would perform the annual inspections, and that it would take this supervisor one hour to perform the inspection. Annual costs in the PEA for the building inspections totaled \$16.7 million; after adjusting wage rates to 2010 levels and applying the revised baseline estimate, OSHA in this FEA estimates annual costs of \$14.1 million for the inspection of building roof anchorages.

Table V-23 summarizes the range in costs for a professional engineer to certify building anchorages; OSHA drew these cost estimates from comments in the record, and adjusted the estimates to 2003 dollars using as the deflator the *Consumer Price Index—All Urban Consumers* (BLS, 2007). The costs range from a low of \$175 to a high of \$2,500; this range probably represents the variation in building sizes, complexity of anchorage arrangements, and regional standards. The median value is \$1,000, which is the estimate (in 2005 dollars) applied by OSHA in the PEA.

Table V-23. Estimated Cost for the Certification of Building Anchorages

Source	Estimated Cost		Year	Estimated Cost (2003 Dollars)	
	Low	High		Low	High
Bright, 2007	\$300	\$1,500	2006	\$274	\$1,369
Kreidenweis, 2003	\$1,000	\$2,500	2003	\$1,000	\$2,500
Lebel, 2003	\$175	\$1,000	2003	\$175	\$1,000
Wright, 2003	\$400		2003	\$400	

Source: ERG, 2007.

¹⁴⁵ Since publication of the PEA, DOE released the results from its 2009 Residential Energy Consumption Survey (RECS) (DOE, 2013). According to the 2009 RECS, 1.9 million apartment buildings have 5 to 10 floors, 0.9 million apartment buildings have 11 to 20 floors, and 0.4 million apartment buildings have more than 20 floors.

Summing the three categories of residential buildings, OSHA estimates that there are approximately 3.3 million residential buildings with five or more floors, a total that is identical to OSHA's preliminary estimate of 3.3 million residential buildings with at least five floors.

Therefore, OSHA applied its preliminary estimate of tall residential buildings for this final analysis.

¹⁴⁶ OSHA notes that in the 2010 Proposed Rule, the Agency requested comment on inspection and maintenance of rooftop anchorages but nowhere stated that a revised OSHA standard would require an engineer to perform those duties.

A cost breakdown of inspections and anchor installations provided by Valcourt Building Services (Valcourt; Ex. 358) confirms OSHA's preliminary estimate of the cost for the certification of building anchorages; Valcourt's quote for initial roof certification was \$1,090. For this final cost analysis, OSHA applied the ratio of the 2011 GDP deflator and the 2005 GDP deflator to its preliminary estimate to derive an estimate of \$1,122 in 2011 dollars for initial roof anchor certifications.

Assuming, as indicated earlier, that building owners would certify building anchorages every 10 years, OSHA estimates that 48,750 buildings (one-tenth of 487,500 buildings) would need anchorage certification each year. At an average cost of \$1,122 for certification, annual costs for anchorage certification would total \$54.7 million.

During the course of decennial certifications and annual inspections, engineers will determine that a small percentage of anchorages will need replacement due to failure to meet building codes or other applicable requirements. For this final economic analysis, OSHA has included the cost for the purchase and installation of replacement anchorages. Based on a review of OSHA 2005 inspection data for the Service industry sector (NAICS 54–81), OSHA calculated that 0.23% of inspected anchorages will be found to be out of compliance.¹⁴⁷ Applying this

¹⁴⁷ Of 38,714 OSHA inspection in 2005, 11,469 resulted in citations, of which 1,938 were in Service industry sector (NAICS 54–81). One hundred and sixty-two citations in the Service industry sector referenced Subpart D, and of that total, 15 citations referenced 1910.28, Scaffolds, the existing standard judged by OSHA to be most closely associated with the final provision for anchorages stabilizing suspended scaffolds. (See https://www.osha.gov/dep/enforcement/enforcement_results_05.html and Document ID [OSHA Excel Workbook], Tab Compliance.) Therefore, (11,469 citations/38,714 inspections) * (162 Service industry sector citations in Subpart D/1,938 Service industry sector citations) * (15 Scaffolds citations/162 Subpart D

anchorage failure rate to the annual number of affected buildings, 750,000 building, yields an estimated 1,734 anchors replaced yearly. At a unit cost of \$1,000 per anchor¹⁴⁸ and an installation time of three hours, annual costs for replacement of roof anchors are expected to total approximately \$1.9 million. (See Ex. [OSHA Excel Workbook], Tab annual_27.)

Summing costs for inspecting and certifying building anchorages and replacing faulty anchors, OSHA estimates that annual costs would total \$71.1 million for employer compliance with the anchorage inspection and certification requirements specified by final § 1910.27(b)(1).

RDS distance limitation. Final § 1910.27(b)(2)(i) prohibits the use of a rope descent system (RDS) for heights greater than 300 feet (91 m) above grade unless the employer can demonstrate that it is not feasible to access heights above 300 feet by any other means or that these other means result in a greater hazard to employees than an RDS. Based on comments in the record (Exs. 126; 163; 219; 222; 358), and as discussed earlier in this section, OSHA expects that there are 1,300 buildings over 300 feet tall subject to this limitation. In written testimony, Valcourt Building Services estimated that limiting the RDS distance to 300 feet would lead to an increase in window cleaning costs ranging from 10 to 20 percent (Ex. 358, p. 4). In a comment submitted in response to the 2003 Notice, Braco Window Cleaning Service, Inc. estimated that the 300-ft. limit to RDS would lead to an increase in prices of 30 percent for building owners (Kreidenweis, 2003). As noted earlier in this analysis of costs, Corporate Cleaning Services estimated

citations) = 0.23% probability of a scaffolds citation in Service industry sector.

¹⁴⁸ Google shopping: Grainger roof anchor.

that the RDS distance limit would increase costs for use of suspended scaffolds by up to 30 percent (Ex. 126). Combining the Braco and Corporate Cleaning estimates of percentage cost increase with the Valcourt range of percentage cost increase, OSHA estimates that if a typical window cleaning job on a tall building takes 24 hours for a 4-person crew (production worker loaded wage in NAICS 5617—Services to Buildings and Dwellings is \$19.39), then applying the midpoint of the range of 10 percent to 30 percent (*i.e.*, 20 percent) to the number of affected buildings results in an annual increased labor cost of \$484,000.

In addition to the labor costs associated with this distance limitation, a small fraction of affected buildings will now need to acquire suspended scaffolds (*i.e.*, swing stages) or powered platforms to service windows at distances over 300 feet from the building roof. OSHA believes that building owners will elect to purchase or contract with window cleaning services to purchase the least expensive system that delivers the appropriate level of safety. According to Valcourt, transportable swing-stage systems are available for \$25,000 per unit, and that approximately 10 percent of the affected buildings that they service would need to purchase such units (Ex. 358, p. 4). Therefore, applying the unit cost for suspended scaffolds to 10 percent of affected buildings (10 percent of 1,300 buildings, or 130 buildings), OSHA estimates that employers will incur first-year costs of \$3.25 million. Annualized over 10 years, equipment costs associated with the RDS height limitation will total \$463,000.

Duty To Have Fall Protection and Falling-Object Protection (§ 1910.28)

Table V–24 lists the requirements in this section that are likely to result in new cost burdens on employers.

Table V-24
New Requirements in Final §1910.28, Duty to Have Fall Protection

Paragraph	Subject
§1910.28(b)(1)	The employer must protect employees working on a surface from falls of four feet or greater to a lower level by any of the controls detailed in this paragraph.
§1910.28(b)(4)(ii)(C)	Those employee have been trained [on dockboards] in accordance with §1910.30.
§1910.28(b)(9)	Requirements for proper fall protection systems for fixed ladders that extend more than 24 feet above a lower level; prohibits after specified dates the use of cages and wells for the purpose of fall protection in the absence of personal fall protection systems or ladder safety systems.
§1910.28(b)(10)(ii)	Employees who climb fixed ladders on billboards not equipped with fall protection must receive training and demonstrate the physical capability to perform the necessary work in accordance with §1910.29(h), and meet other requirements specified for qualified climbers; prohibits use of qualified climbers two years after publication of the final rule. Costs associated with training assigned to final §1910.29(h).
§1910.28(b)(13)	For work performed on low-sloped roofs that are 4 feet (1.2 m) or more above a lower level, the employer must protect each employee from falling by using a guardrail system, safety-net system, travel restraint system, personal fall arrest systems, or designated areas; requirements for fall protection depends on the distance the employee is from the roof edge and the type of work being performed.
§1910.28(b)(14)	<p>For slaughtering facility platforms, the employer must protect each employee from fall hazards on the unprotected working side of a platform that is 4 feet (1.2 m) or more above a lower level by using a guardrail system or a travel restraint system. When the employer can demonstrate the use of a the use of a guardrail or travel restraint system is not feasible, the work may be done without guardrails or a travel restraint system provided:</p> <p>(A) The work operation for which fall protection is infeasible is in process;</p> <p>(B) Access to the platform is limited to authorized employees; and</p> <p>(C) The authorized employees are trained in accordance with §1910.30.</p>

Table V-24
New Requirements in Final §1910.28, Duty to Have Fall Protection (continued)

Paragraph	Subject
§1910.28(b)(15)	Employers having walking-working surfaces 4 feet (1.2 m) or more above a lower level not otherwise addressed by final subpart D must protect employees from falling by using a guardrail system, safety-net system, travel restraint system, or personal fall arrest system.

Source: U.S. Department of Labor, OSHA, Directorate of Standards and Guidance, Office of Regulatory Analysis-Safety.

The following discussion presents, by requirement, the details of OSHA's cost analysis for this section.

Chimney-cleaning services. OSHA received comments indicating that the chimney cleaning industry would incur additional costs, when compared to its current practices, and therefore OSHA has included these costs in its analysis. To protect chimney sweeps from falls after they ascend to residential and commercial roofs using ladders or lifting devices, OSHA's cost model determined that, for the roughly 6,000 chimney-sweep companies nationwide, affected employers will use a roof anchor kit that includes a 14-inch steel roof anchor, 50-foot lifeline and hardware assembly, and a 3-foot shock-absorbing lanyard and full-body harness with a unit cost of \$368. In addition, employers will need two harnesses, at \$118 per unit, to equip the typical two-man or three-man crews involved in each job; the cost model assigned three calls daily for each chimney-sweep crew. Based on comments in the record (Ex. 329 (1/18/2011), pp. 97, 101, 162, 176-178), OSHA estimates that 10 percent of chimney-sweep employers currently protect their workers from falls in accordance with the requirements of this final standard. In addition to the initial equipment costs annualized over 10 years, employers will incur the following labor and equipment costs:

- Pre-installation of anchors requiring one-half hour of a production worker's time, at a loaded wage = \$19.39/hour, per anchor;
- Monthly replacement of roof anchors due to deterioration; and
- A production worker's time of five minutes per job to use the lifeline and lanyard system (productivity loss).

Combining annualized initial costs and annual recurring costs for fall protection of chimney sweeps (NAICS 56179), OSHA estimates that the new costs associated with this industry will

total \$12.7 million, or \$2,124 per chimney-sweep company each year.¹⁴⁹

In post-hearing comments, the National Chimney Sweep Guild stated that compliance with the proposed standard is infeasible and would pose a greater hazard during sweep activities typically performed by their members (Ex. 342, p. 3). However, the sweeps guild did not provide information or data on the extent of the infeasibility that the requirement would impose on NCSG members. Indeed, OSHA notes that NCSG's quoted price for the initial installation of a roof anchor-system (\$578) (Ex. 365) is consistent with OSHA's estimate of combined up-front cost for (1) a roof anchor kit (\$368), (2) monthly replacement of a worn roof anchor (\$67) per company, (3) a full-body harness (\$118) for each of the sweeps, and (4) labor for installation of each new or replaced anchor (\$18); Section H of this FEA demonstrates that these costs are feasible economically.

In response to NCSG's concerns, OSHA notes that final § 1910.28(b)(1) provides an exception to the duty for fall protection for work on residential roofs when an employer can

¹⁴⁹Initial equipment (capital) cost = roof anchor kit * no. of chimney sweep companies * (1 - industry baseline) + full body harness unit cost * no. of chimney sweep companies * sweeps needing harness * (1 - industry baseline) = \$368 * 6,000 * (100% - 10%) + \$118 * 6,000 * 2 * (100% - 10%) = \$3,261,600

Initial system installation = no. of chimney sweep companies * time to pre-install anchors * production worker loaded wage * (1 - industrybaseline) = 6,000 * 0.5 hour * \$19.39 * (100% - 10%) = \$52,581.

Annual costs = roof anchor unit costs * no. of chimney sweep companies * monthly anchors per company * months per year + production worker loaded wage * lifeline productivity loss * sweep calls per day * workdays per year * no. of chimney sweep companies * (1 - industry baseline) = \$66.95 * 6,000 * 1 * 12 + \$19.39 * .083 hours * 3 * 250 * 6,000 * (100% - 10%) = \$4,820,400 + \$6,572,621 = \$11,393,021.

Additional, relatively minor training and other costs related to hazard communication and rule familiarization bring the total annualized costs for chimney cleaning services to approximately \$12.7 million.

demonstrate that it is not feasible, or creates a greater hazard, to use guardrail, safety-net, or personal fall arrest systems. In such a case, the employer must develop and implement a fall protection plan that meets the requirements of 29 CFR 1926.502(k) and training that meets the requirements of 29 CFR 1926.503(a) and (c). Based on comment in the record by NCSG (Exs. 342; 365), OSHA determined that, for a small percentage of chimney-sweep jobs, chimney-sweep employers will find it infeasible to install roof anchors or other fall protection systems for technological, contractual, or other reasons. In these cases, the employer must develop a fall protection plan and provide training in accordance with the requirements in subpart M of the construction standards cited above. For this FEA, OSHA did not estimate the costs for fall protection plans and training because it believes that these costs will not exceed the equipment and labor costs described previously. Therefore, OSHA determined that the total cost for employers to protect their employees from fall hazards during chimney-sweep jobs (\$12.8 million, or \$2,128 per chimney-sweep company) is the maximum or worst-case value.

Dockboards. Final § 1910.28(b)(4) would require installation of guardrails or handrails to protect employees on dockboards from falls of four feet or more to a lower level. Employers with dockboards having maximum heights that are less than four feet would not incur costs under this paragraph. This final provision exempts dockboards presenting a fall hazard of four feet up to 10 feet from this requirement when the employer uses the ramp exclusively for material-handling operations with motorized equipment. To qualify for the exception, employers must train their employees in accordance with § 1910.30. OSHA discusses the training costs for this provision later in this section.

ERG estimated that a substantial proportion of dockboards would either not incur costs due to height or would fall under the exception. Thus, OSHA believes that any costs incurred under this provision are unlikely to be substantial. In the proposal, OSHA requested, but did not receive, comment on the potential impacts associated with the duty to protect employees on dockboards from falls. Therefore, OSHA applied its preliminary estimate of non-substantial costs associated with dockboard fall protection in this final analysis.

Fixed Ladders. To address fall safety on fixed ladders that extend more than 24 feet above a lower level, as specified under final § 1910.28(b)(9), OSHA estimates that, of the approximately 3.1 million fixed ladders over 20 feet in height (ERG, 2007, Table A.1), around 328,000 fixed ladders are between 24 and 30 feet high. Beginning 20 years after publication of the final rule, employers would face additional requirements for fixed ladders beyond those found in voluntary consensus standards (notably ANSI-ASC A14.3-2008¹⁵⁰) and the existing OSHA standards. Accordingly, employers must provide workers making climbs of 24 to 30 feet on fixed ladders 20 years after publication of the final standard with additional protections not currently provided by existing voluntary and mandatory industry standards. While much of general industry uses the affected ladders, this use occurs mainly in manufacturing and industrial buildings (105,000 ladders), silos (85,000), water tanks and water towers (53,000), ski lift towers (29,000), communications towers (25,000), and six other types of structures with fixed ladders (30,000) (see Ex. [OSHA Excel Workbook], Tab retrofit 28). The total for all affected fixed ladders is approximately 328,000 (after rounding).

OSHA assigned costs for fall protection on fixed ladders as follows:

- The Agency distributed ladders among NAICS codes according to the number of affected establishments in the industry represented by a NAICS code; for example, if the 85,000 silos with

fixed ladders were primarily in NAICS 3111, Animal Food Manufacturing, OSHA distributed the costs of ladder safety systems among the 1,817 establishments in NAICS 3111;

- OSHA averaged the cost of two leading ladder safety systems (DBI, Miller; average total upfront cost = \$983, including two-hour installation by a production supervisor; the systems are 30 feet in length, and include the cable, cable sleeve, and carabiner);

- The Agency estimated that fixed ladders have an average life of 30 years, that replacement of the fixed ladders would occur evenly across a 30-year period (10,921 ladders replaced each year by new ladders equipped with a safety system), and, with a phase-in date 20 years after publication, some ladders still would require replacement anywhere from one to 10 years after the 20-year phase-in date;

- OSHA calculated first-year costs, then used a seven percent discount rate to annualize over 10 years; first-year costs total \$8.5 million, and annualized costs total \$1.2 million;

- Billboards with fixed ladders greater than 20 ft. were each assigned a 30-ft. ladder safety system; initial costs of \$20.1 million were annualized over ten years, resulting in annualized costs of \$2.9 million.

Therefore, the initial costs for fall protection on fixed ladders total \$28.6 million, with annualized costs of \$4.1 million.

Outdoor advertising (billboards). This provision, § 1910.28(b)(10), covers the use of fixed ladders on billboards serviced by the outdoor-advertising industry. Based on discussions with the Outdoor Advertising Association of America, ERG estimated that the number of billboards with fixed ladders over 20 feet is approximately 20,500 (ERG, 2007). Employees climb billboards from one to more than 12 times a year, whenever they have to change the copy on the billboard. For the purposes of estimating costs, ERG assumed that an employee climbs each billboard an average of six times a year, totaling 123,000 climbs (20,500 billboards × six climbs). Per the requirement in § 1910.140(c)(18) that personal fall protection systems must be inspected before initial use during each workshift, each time an employee climbs a billboard, ERG estimated that the employee takes two minutes to inspect the ladder safety system (246,000 minutes or 4,100 hours).¹⁵¹

¹⁵¹The costs for inspecting ladder safety systems prior to use in outdoor advertising are separate from the costs for overall inspection of fall protection systems discussed below under § 1910.140(c)(18).

Employees who climb billboards are generally in NAICS 5418 (Advertising and Related Services). In 2010, the average wage, including benefits, for this category was \$22.76/hr. Thus, the estimated total cost to inspect ladder safety systems on billboards is approximately \$93,000 per year.

As specified in § 1910.28(b)(10)(ii), until the requirement for fall protection on fixed ladders in outdoor advertising becomes effective two years after publication of the final standard, employees who routinely climb fixed ladders on billboards must satisfy the criteria for qualified climbers found in § 1910.29(h), *i.e.*, must undergo training, demonstrate the capacity to perform the necessary climbs safely, use a body harness equipped with an 18-inch rest lanyard, have both hands free of tools or material when ascending or descending a ladder, use a fall protection system upon reaching the work position. For the purpose of estimating costs, OSHA determined that all employees who climb billboards are qualified climbers and that the training for a qualified climber includes instruction on having both hands free while ascending or descending the ladder (see final § 1910.29(h)(2)). After the two-year phase-in period, employers will protect employees from fall hazards using on billboards using ladder safety systems, cages or wells, and personal fall arrest systems, which will require substantively identical training to the training specified by final § 1910.29(h)(2). For the PEA, OSHA assigned the costs to train a qualified climber under proposed § 1910.28(b)(10)(v) through § 1910.29(h); for this FEA, OSHA applied the same cost methodology (*i.e.*, assigned costs to § 1910.29(h)).

Low-slope roofs. Final § 1910.28(b)(13) standard requires employers to protect employees working on low-sloped roofs and exposed to fall hazards that are four feet (1.2 m) or more to lower levels. If the employee is working less than six feet (1.8 m) from the edge of the roof, the employer must use a guardrail system meeting the requirements of § 1910.29 of the subpart, a travel restraint system meeting the requirements of subpart I of the part, or a personal fall arrest system meeting the requirements of subpart I of the part. If the employee is working at a distance more than six feet (1.8 m) but less than 15 feet from the roof's edge, employers must protect the employees using a guardrail system meeting the requirements of § 1910.29 of the subpart, a travel restraint system meeting the requirements of subpart I of this part, a personal fall arrest system

¹⁵⁰In ANSI-ASC A14.3-2008, American National Standard for Ladders—Fixed—Safety Requirements, the following provisions lead OSHA to infer that the use of ladder safety systems for ladder heights above 24 feet has become accepted industry practice.

4.1.2 A cage or ladder safety system shall be provided where the length of climb is less than [sic] 24 feet but the top of the ladder is at a distance greater than 24 feet above ground level, floor, or roof (See Fig. 3).

4.1.3 A ladder safety system shall be provided where a single length of climb is greater than 24 feet

meeting the requirements of subpart I of this part, or, if the work is infrequent and temporary, work in a designated area meeting the requirements of § 1910.29 of the subpart. Finally, if the work is taking place 15 feet or more from the edge of the roof, the employer is not required to provide fall protection or use a designated area provided the work is both infrequent and temporary and the employer implements and enforces a work rule prohibiting employees from going within 15 feet (4.6 m) of the roof edge without using fall protection in accordance with paragraphs (b)(13)(i) and (ii).

To estimate compliance costs for this provision, OSHA determined that the most significant incremental burden involves inspections or assessments of rooftop conditions prior to performing any work on the roof. The Agency assumed that most work on rooftops is infrequent and temporary, and occurs in areas that are six to 15 feet from the roof edge, thereby eliminating the need for guardrails, travel restraint systems, and personal fall arrest systems, and using designated areas instead.

Similarly, for work performed 15 feet (4.6 m) or more from the roof edge, OSHA anticipates that most employers will adapt, at minimal cost, existing company work rules and training programs to comply with the final rule. As discussed earlier in this Preamble, OSHA's choice of regulatory text for § 1910.28(b)(13)(iii) makes the final rule consistent with OSHA policy specified in a series of Agency interpretations of the construction fall protection standard for work performed 15 feet or more from the edge of a roof (see, e.g., letter to Mr. Anthony O'Dea (12/15/2003);¹⁵² letter to Mr. Keith Harkins (11/15/2002);¹⁵³ letter to Mr. Barry Cole (5/12/2000)¹⁵⁴).

For work six feet or less from the roof edge with extensive fall exposure, and for work that is less than 15 feet from the edge that is not infrequent and temporary, OSHA believes that, where feasible, the majority of employers currently provide conventional fall protection (guardrails, travel restraint systems, or personal fall arrest systems) and therefore compliance costs will be insubstantial. OSHA bases this estimate in part because the final rule is

consistent with provisions in the construction standard that require employers to provide conventional fall protection for workers exposed to unprotected sides and edges, and most leading edges (§ 1926.501(b)(1) and (2)). In addition, OSHA recognizes that awareness of existing consensus standards on fall protection—including ANSI A1264.1–2007, Safety Requirements for Workplace Walking/ Working Surfaces and Their Access; Workplace, Floor, Wall and Floor Openings; Stairs and Guardrail Systems—have heightened use of conventional fall protection at roof perimeters and will minimize any incremental costs associated with final § 1910.28(b)(13).

Assuming one affected rooftop per affected establishment, OSHA estimated that twice per year, with the exception of establishments in agriculture, forestry, fishing, and hunting, affected employers would direct a production worker to conduct a five-minute assessment of all fall-related conditions on the low-slope roofs of facilities (the inspection time includes any follow-up assessment addressing safety concerns). Summing these labor costs across all affected NAICS codes, OSHA estimates that employer expenditures for inspection of low-slope roofs will total \$34.2 million annually in this FEA.

A small percentage of roof-top inspections are expected to reveal to employers the need for conventional fall protection near unprotected sides and edges. Basing calculations on 2005 OSHA inspection data, OSHA estimates that, depending on the NAICS sector, the probability of identifying an unguarded hazard during a rooftop climb and inspection will range from 0.07% to 0.28%. Applying these probabilities to the number of inspections (described above) and assuming that any enhancement of fall safety will be roughly equivalent to a fifteen-minute labor expense in the installation of an anchor (\$67) suitable for use with a personal lifeline and full-body harness (fully supplied at the baseline), OSHA estimates that the costs for addressing hazards identified in rooftop climbs and inspections will total \$1.85 million. (See Ex. [OSHA Excel Workbook], Tab annual_28.)

Summing employer expenditures for roof inspections and the costs of correcting the hazards identified in those inspections, total costs will be approximately \$36.1 million.

Slaughtering facility platforms. Final § 1910.28(b)(14) is a new provision not in the proposal that requires employers to protect each employee on the unprotected working side of a

slaughtering facility platform that is four feet (1.2 m) or more above a lower level from falling by using guardrails or travel restraint systems. When the employer can demonstrate that using guardrail systems or travel restraint systems is not feasible, employees may perform the work without guardrails or a travel restraint system provided that the work operation for which guardrails or travel restraint systems are infeasible is in process, the employer limits access to the platform to authorized employees, and trains the authorized employees in accordance with § 1910.30.

To derive compliance costs for this provision, OSHA estimated that, of the 3,817 establishments in NAICS 3116, Animal slaughtering and processing, 25 percent are currently in compliance. The Agency based this estimate on comments by the United Food and Commercial Workers at the OSHA public hearing (Ex. 329 (1/20/2011), pp. 63, 90) indicating that a few large meatpacking plants already installed travel restraint systems for fall protection on slaughter (kill) platforms. OSHA believes that, while the meatpacking plants identified in the rulemaking record determined that travel restraint systems are technologically feasible, other affected plants will choose instead to install guardrails at a cost that is potentially lower than the cost of travel restraint systems. Therefore, the Agency estimated that, on average, 10 platforms per establishment will need fall protection and that each establishment will install two portable guardrails, at an initial cost of \$256 per guardrail, on the unprotected working side of slaughter-facility platforms stations, with the installation taking 10 minutes of labor per guardrail (production worker wage = \$17.19/hour). OSHA estimates that initial costs for 2,863 establishments in NAICS 3116 will total \$14.7 million. Annualized over 10 years at a seven percent discount rate, compliance costs will sum to a little under \$2.1 million per year for employers in animal slaughtering and processing facilities.

Walking-working surfaces not otherwise addressed. In final § 1910.28(b)(15), OSHA introduces a duty to provide fall protection for surfaces not otherwise addressed in this section. Among the surfaces affected by this catch-all paragraph are stepbolts. OSHA determined that this requirement for protection on stepbolts will primarily affect establishments in NAICS 51, Information, and NAICS 7113, Promoters of performing arts, sports, and similar events, and that the preferred fall protection will be ladder

¹⁵² OSHA letter to Mr. O'Dea available at: http://www.osha.gov/pls/oshaweb/owadisp.show_document?p_table=INTERPRETATIONS&p_id=24682.

¹⁵³ OSHA letter to Mr. Harkins available at: https://www.osha.gov/pls/oshaweb/owadisp.show_document?p_table=INTERPRETATIONS&p_id=24552.

¹⁵⁴ OSHA letter to Mr. Cole available at: https://www.osha.gov/pls/oshaweb/owadisp.show_document?p_table=INTERPRETATIONS&p_id=24802.

safety systems. For NAICS 51, OSHA estimated there were 97,000 step-bolt structures requiring ladder safety systems across 16 four-digit NAICS industries (6,063 structures per NAICS industry). After accounting for significant baseline use of ladder safety systems (80 percent in OSHA's estimation), the Agency assigned costs for the purchase and installation of these systems at \$908/unit. Similarly, for NAICS 7113, OSHA assigned costs for the purchase and installation of ladder safety systems (\$908/unit) for 2,613 structures with stepbolts (the estimated baseline use of ladder safety systems was again 80 percent). Annualized over 10 years at a seven percent discount rate, costs were \$2.7 million.

Fall Protection Systems and Falling-Object Protection—Criteria and Practices (§ 1910.29)

For proposed § 1910.29, OSHA determined that two requirements would impose significant new burdens on employers. Below are the details of OSHA's approach to estimating costs for this section of the standard.

Inspection of manila, plastic, or synthetic rope. The final regulatory text for § 1910.29(b)(15) requires inspection of manila, plastic, or synthetic rope used as rails and specifies that employers conduct such inspections as frequently as necessary to ensure that the rope meets the strength requirements specified in that section. The estimated inspection cost, then, would be the product of the:

- Number of guardrail systems;
- Proportion that use manila, plastic, or synthetic rope used as top rails or midrails;
- Number of inspections per year;
- Time required for each inspection (hours); and
- Average wage per inspector per industry (\$/hr.).

For the PEA, OSHA lacked data on the proportion of guardrail systems that use manila, plastic, or synthetic rope as top rails or midrails. However, OSHA considered it likely that employers would include the inspection of these alternate materials for top rails and siderails in the inspections performed under § 1910.22, the general inspection requirements for walking-working surfaces for safety. Therefore, OSHA allocated no additional costs to this provision in the PEA.

For this FEA, OSHA estimated that a small percentage of employers would identify defective rope (in rail systems) as a result of the inspections implied by final § 1910.29(b)(15) and that these employers would purchase and install

replacement rope. At \$2.12 per foot for an estimated 20-foot (rescue-grade) guardrail rope with a working load limit of 900 lb. to 1,195 lb., and after accounting for baseline compliance with current floor guarding regulations (see Ex. [OSHA Excel Workbook], tab annual 29_b), and with an installation time of 10 minutes, OSHA estimates that the costs for repair or replacement of guardrail rope will total \$0.67 million.

Outdoor advertising. Final § 1910.29(h) concerns the use of qualified climbers in the outdoor-advertising/billboard industry. Qualified climbers are an option available only to this industry for two years following publication of the final standard. Final paragraph (h) requires that qualified climbers:

- Be physically capable of performing the climbing duties (§ 1910.29(h)(1));
- Undergo training or an apprenticeship program (§ 1910.29(h)(2));
- Be retrained as necessary (§ 1910.29(h)(2));
- Have the skill necessary to climb ladders, as demonstrated through formal classroom training or on-the-job training, and personal observation (§ 1910.29(h)(3)); and
- Perform climbing duties as one of their routine work activities (§ 1910.29(h)(4));

For the purposes of estimating costs, OSHA in the PEA assumed that 90 percent of the employees in the outdoor advertising industry who climb already had training as qualified climbers. Thus, there would be one-time costs associated with qualifying the remaining 10 percent of climbers. OSHA annualized these costs over 10 years at a rate of seven percent. The industry incurs annual costs for:

- Classroom training of new employees (§ 1910.29(h)(2) and (h)(3));
- Retraining of employees as necessary (§ 1910.29(h)(2));
- Employer performance observation (§ 1910.29(h)(3)); and
- Administrative costs to document training and retraining.

For calculating one-time costs in the PEA, OSHA estimated that 713 out of 7,132 of the employees (10 percent) who perform construction, installation, maintenance, and repair operations in NAICS 5418 (Advertising and related services) would need to undergo training to be qualified climbers.

The National Association of Tower Erectors developed a climber-training standard with varying levels of expertise (authorized, competent, and competent rescuer), but does not offer training itself (NATE, 2006). The OSHA Training

Institute offers three-day and four-day training courses in fall protection, the fees for which range from \$549 to \$795. Commercial courses in fall protection reviewed by ERG on the internet in the mid-2000s ranged from one to five days with costs ranging from \$500 to \$2,500 per course (ERG, 2007). The prices include materials and the trainer's time.

For the purpose of estimating costs, OSHA in the PEA estimated that employers could meet the requirements in the proposed standard by sending employees to a four-day training course at a cost of \$1,500 for the course and \$684 for the employee's time (based on an average wage of \$21.39/hour for 32 hours), for a total of \$2,184.

Furthermore, the Agency estimated that the administrative tasks to document the training would require 15 minutes of a supervisor's time (\$36.22/hour) for every 10 employees trained. OSHA in the PEA estimated that the one-time cost to qualify the estimated 713 climbers would be \$1.56 million, and the annualized cost would be \$0.22 million per year.¹⁵⁵ For this FEA, the Agency updated the employee's wage rate (\$22.76/hour), the supervisor's wage rate (\$36.07/hour), and the number of affected employees (10 percent of 8,000, or 800 employees), resulting in an estimated one-time cost of \$1.78 million, with an annualized cost of \$0.25 million at a seven percent discount rate over 10 ten years.

For the purposes of estimating the annual costs associated with this provision, OSHA, consistent with the method presented in the PEA, applied the following unit estimates and assumptions:

- A supervisor observes each of the estimated 8,000 qualified climbers for 15 minutes per quarter or 1 hour per qualified climber per year;
- A supervisor spends 15 minutes per year per qualified climber on administrative tasks for training and retraining;
- Ten percent of the climbers need retraining;
- Retraining consists of an eight-hour refresher course at a cost of \$500; and
- The turnover rate is 47 percent;
- In the absence of this rule, no newly-hired workers would receive training that is compliant with the rule's requirements.

Based on these estimates and assumptions, OSHA determined that the annual cost of this provision would be \$12.2 million, of which \$11.6 million

¹⁵⁵ Employers may offer on-the-job training, and would presumably do so if the costs are less than the costs of commercial training. Thus, the estimated costs presented here may be conservative.

involves training new hires.¹⁵⁶ OSHA requested comment in the proposal on the assumptions and unit-cost estimates that it applied in its analysis of costs for qualified-climber training. In a post-hearing comment, the Outdoor Advertising Association of America (OAAA) provided data on the estimated number of sign structures (120,000 units), professional climbers (1,800 climbers), and climbs on fixed ladders (14,400 climbs per day) for OAAA member companies (Ex. 260). Although OAAA's figure for the number of climbers (1,800) is considerably lower than OSHA's estimate (8,000), OSHA notes that not all outdoor advertisers are OAAA members. Without further data on the number of professional climbers in the industry, OSHA was not able to further refine its preliminary estimate that all employees in NAICS 5418, Advertising and Related Services, involved with construction, installation, maintenance, and repair operations would be affected by the requirement for qualified-climber training. Therefore, other than applying the Census-related update from 7,132 affected workers to 8,000 affected workers, OSHA applied the PEA methodology to this FEA without change.

Training Requirements (§ 1910.30)

Fall hazards and equipment hazards. Final § 1910.30(a) addresses training with respect to fall hazards for employees who use personal fall protection systems or who must receive the training specified elsewhere in subpart D before the employer exposes employees to a fall hazard. This provision requires that a qualified person conduct the training and the training:

- Include the types of fall hazards found in the workplace;
- Describe the procedures employees are to follow to minimize these hazards;
- Address the correct and safe procedures for installing, inspecting, operating, maintaining, and disassembling the personal fall protection systems the employee uses; and
- Address the correct and safe use of personal fall protection systems and equipment specified by this section, including, but not limited to, proper hook-up, anchoring, and tie-off techniques, and methods of equipment inspection and storage, as specified by the manufacturer.

Final § 1910.30(b) addresses training with respect to equipment hazards. In

particular, employers must train employees in the proper:

- Care, storage, use, and inspection of equipment covered by subpart D before their use in accordance with recognized industry practices and manufacturer's recommendations;
 - Placement and securing of dockboards to prevent unintentional movement;
 - Rigging and safe use of rope descent systems; and
 - Set-up and use of designated areas.
- OSHA included the costs for training required under final § 1910.27(b)(2) (Use of rope descent systems), § 1910.28(b)(1) (Unprotected sides and edges), and § 1910.28(b)(4) (Dockboards) in the cost estimate for final § 1910.30.

In a previous analysis, ERG estimated the number and percent of employees by industry that use personal protective equipment (PPE) such as body belts and body harnesses (ERG, 1999; Ex. 318). For the PEA, OSHA applied these industry-specific percentages to the number of at-risk employees in 2007 to estimate the number of employees that need the type of training required under § 1910.30. For this FEA, OSHA applied the preliminary industry-specific PPE percentages to the number of at-risk employees to derive an estimate of employees requiring PPE training.

Some companies already provide this training. OSHA used data from the NOES survey (described above) to estimate, by NAICS code, the level of training already provided. For the purpose of estimating costs in the PEA, OSHA assumed that employees not already trained and using personal fall protection systems would undergo six hours of training on fall hazards and equipment hazards to address the requirements in proposed § 1910.30(a) and (b)(1). For this FEA, OSHA applied the PEA's per-employee estimate of six hours of training for determining the costs of final § 1910.30(a) and (b)(1).

In the PEA cost model, OSHA assigned employees in the utility, sewage, and communications industry sectors (NAICS 2211–2213 and 5121–5191) an additional half-day of training to specifically address the proposed requirements for step bolts (for a total of 10 hours of training). Similarly, the Agency assigned employees in NAICS codes 4881 through 4884 (support activities for transportation by air, rail, water, and road, respectively) a half-day of training specifically to address requirements for dockboards. OSHA assigned window washers, found in NAICS 5617 (Services to buildings and dwellings), an entire day of training on rope descent systems (for a total of 14 hours of training). OSHA applied these

preliminary training-cost estimates to this FEA. In addition, for this FEA, OSHA applied an hour of training on the use of fall protection equipment to employees in every NAICS code, except those codes listed immediately above, for which OSHA's PPE cost survey (ERG, 1999) indicated the presence of employees who use fall protection equipment.

As specified in the final standard, a qualified person provides the required training. For the purpose of estimating costs, OSHA (as it did in the PEA and also in this FEA) assumed that the qualified person conducts the training at the workplace for a fee of \$500 per day. The training fee includes instruction, travel, lodging, and per diem expenses, as well as hand-out materials. Employers incur this fee for every 10 employees (*i.e.*, a class size of 10 employees). OSHA estimates that a supervisor would spend 15 minutes per employee per year performing administrative tasks such as maintaining and updating training records.

The estimated total initial one-time cost for final § 1910.30(a) and (b) is \$123.6 million. The annualized cost over 10 years at a discount rate of seven percent is \$17.6 million. There also is an annual cost for training new employees on PPE and dockboards. OSHA applied BLS hires rates to estimate the annual number of new employees requiring training;¹⁵⁷ the estimated annual cost for this requirement is \$54.6 million.

Ameren Corporation appeared to believe that OSHA's time estimates of course durations used in its cost algorithms for training implied that the Agency would enforce minimal time standards for training. Ameren stated, "There should be no time requirement. This moves away from performance based completely. The training should

¹⁵⁷ The BLS 2007 hires rates applied in the analysis are as follows: Mining and Logging (NAICS 1133, 2111)—45.4 percent; Durable Goods Manufacturing (NAICS 321, 33)—29.8 percent; Nondurable Goods Manufacturing (NAICS 31, 322, 323, 324, 325, 326)—36.9 percent; Transportation, Warehousing, and Utilities (NAICS 22, 48–49)—36.3 percent; Wholesale Trade (NAICS 42)—34.9 percent; Retail Trade (NAICS 44–45)—58.8 percent; Information (NAICS 51): 31.2 percent; Finance and Insurance (NAICS 52): 31.7 percent; Real Estate and Rental Leasing (NAICS 53)—47.6 percent; Professional and Business Services (NAICS 54–56)—63.1 percent; Educational Services (NAICS 61)—30.7 percent; Health Care and Social Assistance (NAICS 62)—35.4 percent; Arts, Entertainment, and Recreation (NAICS 71)—81.8 percent; Accommodation and Food Services (NAICS 72)—82.8 percent; and Other Services (NAICS 81)—41.9 percent. The annual number of affected new employees totals 233,328 within 6.9 million affected establishments, or 0.03 employees per affected establishment.

¹⁵⁶ OSHA assumes that qualified climbers could not transfer their training from one employer to another employer.

cover the elements of all the fall protection systems that an employee will encounter and the uses, restrictions, etc. of each” (Ex. 189). In response, OSHA notes that the time estimates used in its cost analyses for training and other requirements for a safety program are only to illustrate the Agency’s estimates of typical or average times to complete these requirements, and that actual times may vary substantially from these estimates.

Retraining. Final § 1910.30(c) concerns the need to retrain employees whenever the employer has reason to believe that retraining is necessary for safety purposes. This need can occur because of changes in the workplace, fall protection systems, or fall protection equipment that render previous training invalid; or finding that employee knowledge or use of fall protection systems or equipment is no longer adequate. In the PEA, OSHA assumed that retraining already occurs at establishments that have training programs in place. For the remaining employees, OSHA assumed that five percent require retraining each year. OSHA estimated that the retraining course consists of a one-hour supervisor-led refresher course that focuses on the areas in which the employee is deficient. For this FEA, the estimated annual costs for retraining total \$2.0 million.

b. Estimated Compliance Costs by Provision in the Final Standard for Subpart I

Hazard assessment. Final § 1910.132(d) requires an employer to assess the workplace to determine if hazards are present or are likely to be present. In the PEA, OSHA assumed that the time needed by an employer to walk around the workplace, assess the potential hazard, and determine the appropriate PPE and training needed by the employees would vary with the size of the establishment. OSHA used the number of employees as an indicator of establishment size. OSHA estimated the time required for the hazard assessment as:

- 1 to 19 employees: 1 hour
 - 20 to 99 employees: 2 hours
 - 100 to 499 employees: 3 hours
 - 500+ employees: 4 hours
- Furthermore, OSHA assumed:
- All establishments in the forestry, oil and gas, utility, manufacturing, and transportation sectors (NAICS 1131 through 3399 and 4811 through 4931) would perform a hazard assessment because of the high level of risk involved in these sectors;
 - Half the establishments in wholesale and retail sales (NAICS 4231

through 4543) would have slip, trip, or fall hazards such that they would be required to perform a hazard assessment;

- One-quarter of the establishments in the service industries (NAICS 5111 through 8139) would have slip, trip, or fall hazards such that they would be required to perform a hazard assessment; and
- According to the original Regulatory Impact Analysis for PPE and as reported in the 2013 Information Collection Request for PPE in general industry, 47 percent of establishments conduct the initial hazard assessment as a usual and customary practice.¹⁵⁸

This analysis resulted in a one-time cost of \$79.0 million in the PEA, with an annualized cost of \$11.3 million at seven-percent discount rate over 10 years. For this FEA, after adjusting for differences in wages and industry size and composition since the publication of the NPRM, one-time costs for the hazard-assessment requirement were \$85.2 million, with annualized costs of \$12.1 million.

In addition to the costs for assessing hazards in walking-working environments where the use of fall protection will be necessary, OSHA anticipates that employers will incur expenditures to address any hazards identified during the assessments. According to 2005 OSHA inspection data, the likelihood of a compliance violation of current Subpart D ranges from 0.24 percent (of inspections) for the Finance and Insurance industry sector to 0.81 percent for Wholesale Trade sector. Multiplying these noncompliance rates by the annual number of new employers entering business (determined by NAICS code as the product of a 7 percent establishment turnover rate and the number of establishments) and the cost of a typical correction—the purchase and ten-minute installation of a 6-ft. portable guardrail (\$256 per guardrail + labor)—OSHA estimates that the costs for correcting hazards identified by the assessments required under § 1910.132(d) will total \$0.52 million. (See Ex. [OSHA Excel Workbook], tabs Compliance and Hazard Assessment & Training.)

Summing the costs for hazard assessment and hazard correction implied by compliance with final § 1910.132(d), OSHA estimates that total

costs for this provision will be approximately \$12.7 million.

Ameren Corporation questioned whether, in light of existing OSHA standards, OSHA’s assignment of costs for this provision was necessary. Ameren stated, “This seems to be redundant whereas currently assessing fall protection needs is performed in accordance to the specific standard in which it is addressed” (Ex. 189). In response, OSHA notes that, prior to the publication of the fall protection requirements in final subpart I, no standard explicitly requiring hazard assessment for fall protection in the workplace existed for general industry; therefore, OSHA must account for the incremental compliance burden resulting from these requirements.

PPE training. Final § 1910.132(f) requires that employers train employees before they use PPE in the workplace. OSHA included the costs for this final provision in the costs for § 1910.30, described earlier.

PPE inspection. Final § 1910.140(c)(18) requires employers to inspect that personal fall protection systems before the initial use during each work shift for mildew, wear, damage, and other deterioration, and remove defective components from service. For the purposes of estimating costs, OSHA in the PEA assumed that *on average* each production employee who requires fall protection wears a personal fall protection system regularly, performs the required inspection *once a week* at the beginning of every workweek, works 50 weeks per year, and takes one minute to inspect the fall protection system (wage rates varied across four-digit NAICS codes). Beginning with a baseline estimate of the number of workers using fall protection (2.1 million employees), OSHA accounted for current PPE inspection (“current compliance”) by applying results from the NIOSH NOES database. In its use of that survey, OSHA regarded the percentage of employers conducting safety training as a reasonable proxy for PPE inspection. Reducing the affected workforce by the percentage currently conducting PPE inspection, OSHA derived a final estimate of 362,000 affected employees. OSHA’s estimated cost for this provision in the PEA was approximately \$7.3 million per year; for this FEA, the Agency estimated the cost to perform the inspection to be \$10.2 million a year.

Inspection of personal fall arrest systems will likely lead to the discovery of defective PPE, resulting in costs to repair or replace out-of-compliance PPE. OSHA expects that most employers will

¹⁵⁸ See the Information Collection Request For Personal Protective Equipment (PPE) For General Industry (29 CFR Part 1910, Subpart I) Office of Management and Budget (OMB) Control No. 1218–0205 (January 2013), p. 5. Docket No. OSHA–2013–0004, Document ID 0002.

opt to replace faulty PPE; to simplify the calculation of costs, OSHA conservatively chose one of the most expensive types of PPE needing replacement, a full-body harness (\$118 per unit) and applied a non-compliance rate to the percentage of employers who at the baseline (*i.e.*, lacking NIOSH NOES training) are currently not conducting PPE inspection. To estimate the rate of non-compliance, OSHA identified current Subpart M, Fall Protection, § 1926.502, Fall protection systems criteria and practices, in the construction CFR, as the standard analogous to final § 1910.140. The OSHA inspection database for the most recent fiscal year (2015) reports that of 38,029 inspections in NAICS 23, Construction, 544 inspections, or 1.43 percent, resulted in citations for violation of § 1926.502.¹⁵⁹ Applying this PPE criteria violation rate in Construction, 1.43 percent, to the number of affected establishments in

general industry, and multiplying that product times the unit cost of harnesses, OSHA estimates that the cost for replacing defective PPE under § 1910.140 will total \$0.85 million.

Summing the costs for PPE inspection and PPE replacement, OSHA estimates that employers will incur \$11.0 million in new costs associated with the final provisions under § 1910.140.

Rule Familiarization

For this final economic analysis, OSHA has added an estimate for the compliance expenditures incurred by employers to gain familiarity with the final rule. OSHA estimated costs for rule familiarization by applying the methodology described above for Hazard Assessment and Training (§ 1910.132(d)), shown in the following exhibit. All other training costs associated with the final standard are addressed above under § 1910.30.

For the industries with less than 100 percent share needing hazard

assessment, OSHA applied the estimated percentage to the time assumptions shown in Exhibit V-3. For example, for a very small (<20 employees) retail establishment: 50% needing familiarization * 10 minutes = 5 minutes per employer. For the industries where 100 percent of establishments will conduct hazard assessment, the average unit time per employment range (1-19, 20-99, etc.) shown in the exhibit was multiplied times the entire number of number of establishments whose employment falls within the range, by four-digit NAICS industry.¹⁶⁰ All affected NAICS industries and establishments were costed. Labor costs were calculated using supervisor loaded wage, by NAICS industry. Costs for rule familiarization are expected to total \$28.5 million in first-year costs, or \$4.1 million per year when annualized over ten years.

Exhibit V-3 Rule Familiarization

Baseline Assumptions			
Rule Familiarization (minutes)		Share of Establishments Needing Hazard Assessment	
		Forestry, etc.	100.0%
		Oil and gas	100.0%
		Utility	100.0%
		Manufacturing	100.0%
1-19 Employees	10	Transportation	100.0%
20-99 Employees	15	Wholesale	50.0%
100-499 Employees	20	Retail	50.0%
500+ Employees	30	Service	25.0%

Source: US Dept. of Labor, OSHA, Directorate of Standards and Guidance, Office of Regulatory Analysis – Safety.

¹⁵⁹ See https://www.osha.gov/pls/imis/industry_profile.stand?p_esize=&p_stand=19260502&p_state=FEFederal&p_type=2 and https://www.osha.gov/pls/imis/industry.search?p_logger=1&sic=&naics=23&State=All&officetype=All&Office=All&endmonth=10&endday=01&endyear=2014&startmonth=09&startday=30&startyear=2015&owner=&scope=&FedAgnCode=.

¹⁶⁰ For example, for NAICS 2211: Electric power generation, transmission and distribution, in the Utility industry sector, the cost calculation was as follows: ((1,529 very small establishments * 0.17 hours) + (152 small establishments * 0.25 hours) + (30 mid-size establishments * 0.33 hours) + (44 large establishments * 0.5 hours)) * (\$54.24 production worker supervisor hourly wage for

NAICS 2211) = \$17,620. Analogous calculations were performed for each industry and summed to produce a total of \$28.5 million in first-year costs. See Ex. [OSHA Excel workbook], tab Rule Familiarization.

7. Cost Summary

Tables V–25 through V–27 summarize the costs by industry for each paragraph in the final standard. Table V–25 lists the first-year costs, which employers incur once to comply with the new requirements. For evaluating economic impacts, OSHA annualized these one-time costs over a 10-year period at a discount rate of 7 percent. Total first-year costs for final subparts D and I are \$319.5 million, with annualized costs for the first year of \$45.5 million.

Table V–26 lists the recurring annual costs, such as inspections, training new employees, and maintaining safe conditions when fall hazards remain; OSHA estimates these costs to be \$259.0 million. Table V–27 lists the annual costs by industry, which include the sum of the recurring costs and the annualized one-time costs; OSHA estimated these costs at \$305.0 million.

Listing annualized costs in descending order by section of the rule, OSHA projects that the most costly provisions address training programs (\$74.2 million), scaffolds and rope descent systems (\$71.6 million), duty to have fall protection and falling-object protection (\$55.9 million), and general requirements (\$33.2 million). Of these final costs, the most significant change in costs from the PEA involve the costs associated with the duty to have fall protection and falling-object protection

(§ 1910.28) (\$55.9 million in FEA vs. \$0.09 million in the PEA) because the strengthened requirements for fixed ladders, roof edges, slaughtering platforms, and step bolts lead to additional employer expenditures for equipment and labor.

For the category with the second largest compliance costs, scaffolds and rope descent systems, the final standard provides greater specificity than the proposal regarding the need for proper rigging, including sound anchorages and tiebacks. The final rule at § 1910.27(b)(1)(i) and (ii) states that before any rope descent system is used, the building owner must inform the employer, in writing that the building owner has identified, tested, certified, and maintained each anchorage so it is capable of supporting at least 5,000 pounds (22.2 kN) in any direction, for each employee attached and, moreover, that the employer must ensure that no employee uses any anchorage before the employer has obtained written information from the building owner that each anchorage meets the requirements of paragraph (b)(1)(i). Finally, the employer must keep the information on building anchorages for the duration of the job. The information must be based on an annual inspection conducted by a qualified person, with certification of each anchorage performed by a qualified person, as necessary, but at least every 10 years. As

described earlier in this cost analysis, OSHA assumed that building owners and employers would comply with this requirement by scheduling periodic inspections and certifications of building anchorages.

Because of the hazards associated with cleaning windows of office buildings and other tall structures while suspended on scaffolds or other devices (see Table V–6 for the number of reported fatalities in NAICS 561, Administrative and Support Services), OSHA raised the issue of proper safety during window cleaning in the 2003 notice that reopened the rulemaking record, and in the 2010 NPRM. In those notices, OSHA requested comment on the hazards associated with window cleaning and the safe practices recommended and implemented for the use of rope descent systems (68 FR 23534; 75 FR 28862). OSHA based its analysis of the costs of ensuring sound anchorages and rigging, described above, as well as the Agency's analysis of the costs for protecting workers on rope descent systems and suspended scaffolds, on the experiences and observations of the industry representatives who responded to OSHA's request for comment in 2003 and in OSHA's 2010 NPRM; therefore, the Agency believes that the record fully supports this cost analysis.

BILLING CODE 4510–29–P

**Table V-25
First-Year Costs for the Final Standards on Walking-Working Surfaces by Paragraph and Industry**

NAICS	Title	One-Time Compliance Costs									
		§1910.22	§1910.23	§1910.24	§1910.27	§1910.28	§1910.29	§1910.30	Subpart I – Personal Protective Equipment	Rule Familiari- zation	Total
		General Require- ments	Ladders	Step Bolts and Manhole Steps	Scaffolds and Rope Descent Systems	Duty to Have Fall Protection	Fall Protection Systems Criteria and Practices	Training Program			
11	Agriculture, Forestry, Fishing, and Hunting	\$0	\$3,499	\$0	\$0	\$0	\$0	\$82,299	\$233,034	\$88,181	\$407,014
21	Mining	\$0	\$77,574	\$0	\$0	\$0	\$0	\$2,227,998	\$303,452	\$38,800	\$2,647,823
22	Utilities	\$0	\$255,214	\$0	\$0	\$1,515,369	\$0	\$5,845,491	\$1,340,822	\$122,655	\$9,079,550
31-33	Manufacturing	\$0	\$1,090,980	\$0	\$0	\$19,738,717	\$0	\$18,101,934	\$10,819,814	\$7,441,716	\$57,193,161
42	Wholesale Trade	\$0	\$1,041,883	\$0	\$0	\$0	\$0	\$22,018,269	\$7,190,500	\$451,397	\$30,702,049
44-45	Retail Trade	\$0	\$2,269,667	\$0	\$0	\$0	\$0	\$20,152,641	\$19,493,268	\$3,438,156	\$45,353,732
48-49	Transportation	\$0	\$247,720	\$0	\$0	\$22,623	\$0	\$5,208,568	\$7,538,873	\$9,129,714	\$22,147,499
51	Information	\$0	\$960,867	\$0	\$0	\$19,289,763	\$0	\$16,927,032	\$1,820,813	\$155,354	\$39,153,828
52	Finance and Insurance	\$0	\$42,339	\$0	\$0	\$0	\$0	\$394,333	\$7,689,196	\$505,346	\$8,631,214
53	Real Estate	\$0	\$1,122,286	\$0	\$0	\$0	\$0	\$2,581,443	\$3,290,153	\$100,622	\$7,094,505
54	Professional, Scientific, and Technical Services	\$0	\$411,344	\$0	\$0	\$20,628,640	\$1,783,330	\$7,431,045	\$6,354,017	\$1,653,497	\$38,261,872
55	Management of Companies and Enterprises	\$0	\$167,126	\$0	\$0	\$0	\$0	\$3,702,958	\$881,601	\$250,475	\$4,998,419

**Table V-25
First-Year Costs for the Final Standards on Walking-Working Surfaces by Paragraph and Industry (continued)**

NAICS	Title	One-Time Compliance Costs									Total
		§1910.22	§1910.23	§1910.24	§1910.27	§1910.28	§1910.29	§1910.30	Subpart I – Personal Protective Equipment	Rule Familiari- zation	
		General Require- ments	Ladders	Step Bolts and Manhole Steps	Scaffolds and Rope Descent Systems	Duty to Have Fall Protection	Fall Protection Systems Criteria and Practices	Training Program			
56	Administrative and Support, Waste Management and Remediation Services	\$0	\$1,187,391	\$0	\$3,250,000	\$3,313,958	\$0	\$10,254,174	\$2,595,784	\$1,424,800	\$22,026,107
61	Educational Services	\$0	\$298,035	\$0	\$0	\$1,557	\$0	\$0	\$714,625	\$1,090,094	\$2,104,311
62	Health Care	\$0	\$43,697	\$0	\$0	\$0	\$0	\$1,079,226	\$5,301,379	\$1,087,208	\$7,511,510
71	Arts, Entertainment, and Recreation	\$0	\$198,390	\$0	\$0	\$1,255,837	\$0	\$0	\$808,054	\$723,482	\$2,985,763
72	Accommodation and Food Services	\$0	\$193,370	\$0	\$0	\$0	\$0	\$2,026,529	\$4,709,513	\$331,714	\$7,261,126
81	Other Services	\$0	\$1,856,804	\$0	\$0	\$0	\$0	\$5,528,678	\$4,117,553	\$437,534	\$11,940,569
Total		\$0	\$11,468,187	\$0	\$3,250,000	\$65,766,463	\$1,783,330	\$123,562,617	\$85,198,710	\$28,470,746	\$319,500,053

Source: U.S. Department of Labor, OSHA, Directorate of Standards and Guidance, Office of Regulatory Analysis-Safety.

Table V-26
Recurring Annual Costs for the Final Standards on Walking-Working Surfaces by Paragraph and Industry

NAICS	Title	Recurring Compliance Costs									Total
		§1910.22	§1910.23	§1910.24	§1910.27	§1910.28	§1910.29	§1910.30	Subpart I – Personal Protective Equipment	Rule Familiari- zation [a]	
		General Requirements	Ladders	Step Bolts and Manhole Steps	Scaffolds and Rope Descent Systems	Duty to Have Fall Protection	Fall Protection Systems Criteria and Practices	Training Program			
11	Agriculture, Forestry, Fishing, and Hunting	\$77,491	\$8,206	\$0	\$0	\$0	\$2,055	\$37,959	\$7,313	NA	\$133,024
21	Mining	\$69,064	\$41,639	\$0	\$0	\$52,282	\$1,050	\$1,025,785	\$221,975	NA	\$1,411,795
22	Utilities	\$152,035	\$106,776	\$17,888,009	\$0	\$114,808	\$2,319	\$2,169,123	\$424,226	NA	\$20,857,296
31-33	Manufacturing	\$2,706,603	\$557,737	\$0	\$0	\$1,299,152	\$52,965	\$6,119,290	\$1,661,117	NA	\$12,396,863
42	Wholesale Trade	\$4,459,417	\$634,102	\$0	\$0	\$1,714,428	\$87,022	\$7,865,600	\$1,984,496	NA	\$16,745,065
44-45	Retail Trade	\$6,528,405	\$1,964,987	\$0	\$0	\$3,900,027	\$137,238	\$12,246,404	\$1,796,394	NA	\$26,573,456
48-49	Transportation	\$1,519,820	\$231,425	\$0	\$0	\$976,066	\$29,059	\$1,934,756	\$490,733	NA	\$5,181,859
51	Information	\$1,097,685	\$393,559	\$75,214	\$0	\$686,926	\$20,731	\$5,453,433	\$1,178,402	NA	\$8,905,949
52	Finance and Insurance	\$1,423,407	\$432,055	\$0	\$0	\$2,366,678	\$21,264	\$132,531	\$41,942	NA	\$4,417,877
53	Real Estate	\$927,405	\$806,534	\$0	\$0	\$1,907,789	\$16,032	\$1,429,548	\$281,073	NA	\$5,368,381
54	Professional, Scientific, and Technical Services	\$4,087,399	\$875,058	\$0	\$0	\$4,458,801	\$12,225,546	\$4,761,927	\$804,887	NA	\$27,213,617
55	Management of Companies and Enterprises	\$229,080	\$139,923	\$0	\$0	\$251,583	\$4,168	\$2,366,262	\$405,328	NA	\$3,396,345

**Table V-26
Recurring Annual Costs for the Final Standards on Walking-Working Surfaces by Paragraph and Industry (continued)**

NAICS	Title	Recurring Compliance Costs									Total
		§1910.22	§1910.23	§1910.24	§1910.27	§1910.28	§1910.29	§1910.30	Subpart I – Personal Protective Equipment	Rule Familiari- zation [a]	
		General Requirements	Ladders	Step Bolts and Manhole Steps	Scaffolds and Rope Descent Systems	Duty to Have Fall Protection	Fall Protection Systems Criteria and Practices	Training Program			
56	Administrative and Support, Waste Management and Remediation Services	\$1,379,070	\$956,872	\$0	\$71,125,818	\$19,276,147	\$30,807	\$6,232,062	\$854,682	NA	\$99,855,459
61	Educational Services	\$391,706	\$150,463	\$0	\$0	\$404,817	\$7,106	\$53,205	\$0	NA	\$1,007,296
62	Health Care	\$2,729,005	\$426,058	\$0	\$0	\$3,055,553	\$63,090	\$389,550	\$112,151	NA	\$6,775,407
71	Arts, Entertainment, and Recreation	\$512,352	\$239,450	\$50,491	\$0	\$1,282,056	\$10,097	\$34,427	\$0	NA	\$2,128,872
72	Accommodation and Food Services	\$2,181,327	\$488,931	\$0	\$0	\$1,933,120	\$44,928	\$1,709,797	\$198,915	NA	\$6,557,018
81	Other Services	\$2,714,124	\$1,186,568	\$0	\$0	\$2,852,594	\$59,793	\$2,642,283	\$585,553	NA	\$10,040,915
	Total	\$33,185,393	\$9,640,343	\$18,013,714	\$71,125,818	\$46,532,828	\$12,815,270	\$56,603,941	\$11,049,187		\$258,966,494

[a] Costs for rule familiarization are first-year costs and will not recur in subsequent years.

Source: U.S. Department of Labor, OSHA, Directorate of Standards and Guidance, Office of Regulatory Analysis-Safety.

Table V-27 Annualized Costs for the Final Standards on Walking-Working Surfaces by Paragraph and Industry											
NAICS	Title	Annualized Compliance Costs									Total
		§1910.22	§1910.23	§1910.24	§1910.27	§1910.28	§1910.29	§1910.30			
		General Require-	Ladders	Step Bolts and Manhole Steps	Scaffolds and Rope Descent Systems	Duty to Have Fall Protection	Fall Protection Systems Criteria and Practices	Training Program	Subpart I – Personal Protective Equipment	Rule Familiarization	
11	Agriculture, Forestry, Fishing, and Hunting	\$77,491	\$8,704	\$0	\$0	\$0.00	\$2,055	\$49,676	\$42,213	\$12,555	\$192,695
21	Mining	\$69,064	\$52,684	\$0	\$0	\$52,282	\$1,050	\$1,343,002	\$265,887	\$5,524	\$1,789,493
22	Utilities	\$152,035	\$143,112	\$17,888,009	\$0	\$330,562	\$2,319	\$3,001,389	\$616,692	\$17,463	\$22,151,583
31-33	Manufacturing	\$2,706,603	\$713,068	\$0	\$0	\$4,109,501	\$52,965	\$8,696,598	\$3,240,843	\$1,059,533	\$20,579,110
42	Wholesale Trade	\$4,459,417	\$782,443	\$0	\$0	\$1,714,428	\$87,022	\$11,000,506	\$3,073,123	\$64,269	\$21,181,208
44-45	Retail Trade	\$6,528,405	\$2,288,136	\$0	\$0	\$3,900,027	\$137,238	\$15,115,687	\$4,681,899	\$489,516	\$33,140,909
48-49	Transportation	\$1,519,820	\$266,695	\$0	\$0	\$979,287	\$29,059	\$2,676,339	\$1,584,553	\$1,299,866	\$8,355,618
51	Information	\$1,097,685	\$530,365	\$75,214	\$0	\$3,433,355	\$20,731	\$7,863,461	\$1,443,903	\$22,119	\$14,486,832
52	Finance and Insurance	\$1,423,407	\$438,083	\$0	\$0	\$2,366,678	\$21,264	\$188,675	\$1,158,972	\$71,950	\$5,669,028
53	Real Estate	\$927,405	\$966,323	\$0	\$0	\$1,907,789	\$16,032	\$1,797,087	\$766,104	\$14,326	\$6,395,066
54	Professional, Scientific, and Technical Services	\$4,087,399	\$933,624	\$0	\$0	\$7,395,855	\$12,479,452	\$5,819,940	\$1,766,095	\$235,421	\$32,717,786
55	Management of Companies and Enterprises	\$229,080	\$163,718	\$0	\$0	\$251,583	\$4,168	\$2,893,480	\$533,612	\$35,662	\$4,111,304

**Table V-27
Annualized Costs for the Final Standards on Walking-Working Surfaces by Paragraph and Industry (continued)**

NAICS	Title	Annualized Compliance Costs									
		§1910.22	§1910.23	§1910.24	§1910.27	§1910.28	§1910.29	§1910.30			
		General Requirements	Ladders	Step Bolts and Manhole Steps	Scaffolds and Rope Descent Systems	Duty to Have Fall Protection	Fall Protection Systems Criteria and Practices	Training Program	Subpart I – Personal Protective Equipment	Rule Familiarization	Total
56	Administrative and Support, Waste Management and Remediation Services	\$1,379,070	\$1,125,930	\$0	\$71,588,545	\$19,747,980	\$30,807	\$7,692,026	\$1,249,160	\$202,859	\$103,016,377
61	Educational Services	\$391,706	\$192,896	\$0	\$0	\$405,039	\$7,106	\$53,205	\$107,403	\$155,205	\$1,312,559
62	Health Care	\$2,729,005	\$432,280	\$0	\$0	\$3,055,553	\$63,090	\$543,207	\$917,695	\$154,794	\$7,895,624
71	Arts, Entertainment, and Recreation	\$512,352	\$267,696	\$50,491	\$0	\$1,460,859	\$10,097	\$34,427	\$123,181	\$103,008	\$2,562,109
72	Accommodation and Food Services	\$2,181,327	\$516,463	\$0	\$0	\$1,933,120	\$44,928	\$1,998,329	\$910,366	\$47,229	\$7,631,761
81	Other Services	\$2,714,124	\$1,450,935	\$0	\$0	\$2,852,594	\$59,793	\$3,429,442	\$1,220,007	\$62,295	\$11,789,190
	Total	\$33,185,393	\$11,273,155	\$18,013,714	\$71,588,545	\$55,896,492	\$13,069,176	\$74,196,478	\$23,701,708	\$4,053,594	\$304,978,255

Source: U.S. Department of Labor, OSHA, Directorate of Standards and Guidance, Office of Regulatory Analysis-Safety.

BILLING CODE 4510-29-C

G. Economic Feasibility and Regulatory Flexibility Screening Analysis

1. Introduction

OSHA determined that the costs of complying with the requirements of final subparts D and I will not impose substantial economic impacts on employers in the industries affected by the final rule. The costs imposed by the final standards are modest, and the increased safety and reduction in injuries and fatalities associated with the standards will reduce employers' direct and indirect costs. OSHA based this final economic-impacts analysis on the PEA, the rulemaking record, and revisions to OSHA's preliminary data as described above in section C ("Profile of Affected Industries, Firms, and Workers") and section F ("Costs of Compliance").

Table V-28 summarizes OSHA's final estimate of impacts (annualized costs) for the two-digit NAICS industry groups affected by the final standards. "Minimum" and "Maximum" refer to the lowest and highest costs among the

four-digit NAICS industries categorized within the two-digit group. The following section discusses OSHA's methodology for assessing the significance of the impacts at the aggregate level presented in Table V-29 and at levels of greater industry detail.

2. Economic Screening Analysis

To determine whether the final rule's projected costs of compliance would raise issues of economic feasibility for employers in affected industries, *i.e.*, would adversely affect the competitive structure of the industry, OSHA first compared compliance costs, annualized at a 7 percent discount rate, to industry revenues and profits. OSHA then examined specific factors affecting individual industries for which compliance costs represent a significant share of revenue, or for which the record contains other evidence that the standards could have a significant impact on the competitive structure of the industry.

As noted, OSHA examined the potential impacts of the final rule two ways, *i.e.*, as a percentage of revenues

and as a percentage of profits. Table V-29 presents the estimated average receipts and profits by establishment and industry. In the PEA, OSHA, applying the methodology employed by ERG (ERG, 2007), estimated 2006 receipts based on 2002 receipts and payroll data from U.S. Census Bureau, *Statistics of U.S. Businesses, 2002*, and payroll data from U.S. Census Bureau, *Statistics of U.S. Businesses, 2006*. For that calculation, OSHA assumed that the ratio of receipts to payroll remained unchanged between 2002 and 2006.

For this FEA, OSHA applied *Statistics of U.S. Businesses, 2007* data on establishments, firms, and revenue at the four-digit NAICS level. OSHA estimated profits from ratios of net income to total receipts as reported for 2000-2008 (nine-year average) by the U.S. Internal Revenue Service, *Corporation Source Book* (IRS, 2009). Profit data were not available at disaggregated levels for all industries; therefore, OSHA used profit rates at more highly aggregated levels for such industries.

BILLING CODE 4510-29-P

**Table V-28
Summary of Cost Impacts Associated with OSHA's Final Standards for Subparts D and I**

NAICS	Sector Title	Average Cost per Establishment, Annualized with a 7% Discount Rate		Ratio of Average Annualized Cost to Revenues		Ratio of Average Annualized Cost to Profits	
		Minimum	Maximum	Minimum	Maximum	Minimum	Maximum
		11	Agriculture, Forestry, Fishing, and Hunting	\$9	\$15	0.001%	0.001%
21	Mining*	\$237	\$237	0.001%	0.001%	0.005%	0.005%
22	Utilities	\$240	\$3,444	0.000%	0.169%	0.014%	3.114%
31-33	Manufacturing	\$17	\$634	0.000%	0.002%	0.000%	0.072%
42	Wholesale Trade	\$18	\$91	0.000%	0.001%	0.001%	0.030%
44-45	Retail Trade	\$10	\$94	0.000%	0.004%	0.006%	0.197%
48-49	Transportation	\$18	\$321	0.000%	0.004%	0.000%	0.172%
51	Information	\$23	\$898	0.000%	0.005%	0.002%	0.083%
52	Finance and Insurance	\$9	\$109	0.000%	0.001%	0.000%	0.017%
53	Real Estate	\$11	\$23	0.000%	0.002%	0.000%	0.046%
54	Professional, Scientific, and Technical Services	\$13	\$414	0.001%	0.020%	0.020%	0.390%
55	Management	\$81	\$81	0.001%	0.001%	0.012%	0.012%
56	Administrative and Support, Waste Management and Remediation Services	\$12	\$522	0.001%	0.087%	0.010%	2.076%
61	Educational Services	\$11	\$71	0.000%	0.003%	0.001%	0.034%
62	Health Care	\$7	\$79	0.000%	0.002%	0.001%	0.036%
71	Arts, Entertainment, and Recreation	\$11	\$97	0.000%	0.006%	0.003%	0.072%
72	Accommodation and Food Services	\$9	\$34	0.001%	0.003%	0.021%	0.058%
81	Other Services	\$7	\$35	0.000%	0.005%	0.010%	0.152%

*Includes oil and gas extraction.

Source: U.S. Department of Labor, OSHA, Directorate of Standards and Guidance, Office of Regulatory Analysis-Safety.

Table V-29
Average Cost Impacts on Establishments Affected by OSHA's Final Standards for Subparts D and I
(per Establishment, by 4-Digit NAICS Code)

NAICS	Industry	Average Receipts per Estab. [a]	Profit Rate [b]		Estimated Profits per Estab.	Estimated Cost of Final Rule, Annualized with a 7% Discount Rate	Average Annualized Cost per Estab.	Ratio of Average Annualized Cost to Revenues	Ratio of Average Annualized Cost to Profits
1131	Timber Tract Operations	\$1,669,193	3.46%	*	\$57,813	\$4,220	\$9.38	0.001%	0.016%
1132	Forest Nurseries and Gathering of Forest Products	\$1,522,173	3.46%	*	\$52,720	\$2,424	\$10.49	0.001%	0.020%
1133	Logging	\$1,086,367	3.46%	*	\$37,626	\$142,951	\$14.57	0.001%	0.039%
1141	Fishing	\$1,161,385	5.50%	*	\$63,834	\$19,731	\$9.57	0.001%	0.015%
1142	Hunting and Trapping	\$687,832	5.50%	*	\$37,806	\$3,143	\$9.61	0.001%	0.025%
1153	Support Activities for Forestry	\$819,390	4.60%	*	\$37,689	\$20,224	\$11.52	0.001%	0.031%
2111	Oil and Gas Extraction	\$31,037,522	13.95%		\$4,331,076	\$1,789,493	\$237.27	0.001%	0.005%
2211	Electric Power Generation, Transmission and Distribution	\$45,816,490	4.33%		\$1,984,050	\$5,142,043	\$535.02	0.001%	0.027%
2212	Natural Gas Distribution	\$54,186,767	3.12%		\$1,692,526	\$546,912	\$239.56	0.000%	0.014%
2213	Water, Sewage and Other Systems	\$2,033,163	5.44%		\$110,587	\$16,462,628	\$3,444.06	0.169%	3.114%
3111	Animal Food Manufacturing	\$21,156,444	4.28%		\$904,721	\$280,026	\$154.11	0.001%	0.017%
3112	Grain and Oilseed Milling	\$87,088,549	4.28%	*	\$3,724,202	\$168,055	\$202.48	0.000%	0.005%
3113	Sugar and Confectionery Product Manufacturing	\$15,750,859	7.74%		\$1,218,918	\$91,129	\$50.97	0.000%	0.004%
3114	Fruit and Vegetable Preserving and Specialty Food Manufacturing	\$38,180,019	6.70%		\$2,556,980	\$139,203	\$83.46	0.000%	0.003%
3115	Dairy Product Manufacturing	\$55,896,648	2.60%		\$1,453,511	\$139,328	\$86.43	0.000%	0.006%

Table V-29
Average Cost Impacts on Establishments Affected by OSHA's Final Revision to Subparts D and I
(per Establishment, by 4-Digit NAICS Code) (continued)

NAICS	Industry	Average Receipts per Estab. [a]	Profit Rate [b]		Estimated Profits per Estab.	Estimated Cost of Final Rule, Annualized with a 7% Discount Rate	Average Annualized Cost per Estab.	Ratio of Average Annualized Cost to Revenues	Ratio of Average Annualized Cost to Profits
3116	Animal Slaughtering and Processing	\$40,957,523	2.15%		\$880,691	\$2,418,692	\$633.66	0.002%	0.072%
3117	Seafood Product Preparation and Packaging	\$16,864,564	2.15%	*	\$362,631	\$32,948	\$48.10	0.000%	0.013%
3118	Bakeries and Tortilla Manufacturing	\$5,471,622	8.78%		\$480,359	\$482,242	\$46.96	0.001%	0.010%
3119	Other Food Manufacturing	\$22,381,101	5.36%		\$1,200,230	\$203,393	\$61.45	0.000%	0.005%
3121	Beverage Manufacturing	\$22,087,717	6.67%	*	\$1,473,559	\$201,021	\$50.76	0.000%	0.003%
3122	Tobacco Manufacturing	\$384,255,294	17.89%		\$68,725,423	\$33,533	\$307.64	0.000%	0.000%
3131	Fiber, Yarn, and Thread Mills	\$21,210,811	3.45%	*	\$731,436	\$43,553	\$102.72	0.000%	0.014%
3132	Fabric Mills	\$14,424,042	3.45%	*	\$497,400	\$74,503	\$56.53	0.000%	0.011%
3133	Textile and Fabric Finishing and Fabric Coating Mills	\$6,380,810	3.45%	*	\$220,037	\$139,896	\$103.63	0.002%	0.047%
3141	Textile Furnishings Mills	\$7,732,758	3.68%	*	\$284,230	\$237,842	\$92.08	0.001%	0.032%
3149	Other Textile Product Mills	\$2,612,342	3.68%	*	\$96,021	\$199,917	\$48.18	0.002%	0.050%
3151	Apparel Knitting Mills	\$7,914,945	2.87%		\$227,138	\$77,494	\$159.13	0.002%	0.070%
3152	Cut and Sew Apparel Manufacturing	\$2,602,718	5.00%		\$130,034	\$149,487	\$16.67	0.001%	0.013%
3159	Apparel Accessories and Other Apparel Manufacturing	\$1,890,438	3.92%		\$74,113	\$19,153	\$20.91	0.001%	0.028%
3161	Leather and Hide Tanning and Finishing	\$5,655,201	5.36%	*	\$302,869	\$8,061	\$33.04	0.001%	0.011%
3162	Footwear Manufacturing	\$6,904,902	5.36%	*	\$369,798	\$13,218	\$43.20	0.001%	0.012%
3169	Other Leather and Allied Product Manufacturing	\$3,187,810	5.36%	*	\$170,726	\$16,148	\$19.18	0.001%	0.011%
3211	Sawmills and Wood Preservation	\$6,927,646	2.86%	*	\$198,425	\$144,935	\$34.77	0.001%	0.018%
3212	Veneer, Plywood, and Engineered Wood Product Manufacturing	\$11,371,370	2.86%	*	\$325,704	\$103,186	\$53.63	0.000%	0.016%
3219	Other Wood Product Manufacturing	\$4,758,750	2.86%	*	\$136,302	\$362,631	\$34.44	0.001%	0.025%
3221	Pulp, Paper, and Paperboard Mills	\$149,009,548	3.36%		\$5,005,593	\$283,761	\$514.99	0.000%	0.010%

NAICS	Industry	Average Receipts per Estab. [a]	Profit Rate [b]	Estimated Profits per Estab.	Estimated Cost of Final Rule, Annualized with a 7% Discount Rate	Average Annualized Cost per Estab.	Ratio of Average Annualized Cost to Revenues	Ratio of Average Annualized Cost to Profits
3222	Converted Paper Product Manufacturing	\$21,433,081	7.61%	\$1,630,767	\$535,529	\$119.38	0.001%	0.007%
3231	Printing and Related Support Activities	\$3,053,880	3.99%	\$121,803	\$830,069	\$24.94	0.001%	0.020%
3241	Petroleum and Coal Products Manufacturing	\$247,192,988	7.34%	\$18,134,524	\$610,089	\$253.36	0.000%	0.001%
3251	Basic Chemical Manufacturing	\$88,422,649	4.32%	\$3,818,485	\$613,576	\$241.57	0.000%	0.006%
3252	Resin, Synthetic Rubber, and Artificial Synthetic Fibers and Filaments Manufacturing	\$97,133,198	7.67%	\$7,448,757	\$385,351	\$358.13	0.000%	0.005%
3253	Pesticide, Fertilizer, and Other Agricultural Chemical Manufacturing	\$31,546,951	10.59%	\$3,341,588	\$138,825	\$153.23	0.000%	0.005%
3254	Pharmaceutical and Medicine Manufacturing	\$94,045,735	15.76%	\$14,825,716	\$368,253	\$191.20	0.000%	0.001%
3255	Paint, Coating, and Adhesive Manufacturing	\$17,178,798	5.06%	\$868,584	\$103,173	\$54.13	0.000%	0.006%
3256	Soap, Cleaning Compound, and Toilet Preparation Manufacturing	\$41,957,355	9.72%	\$4,078,034	\$209,286	\$93.39	0.000%	0.002%
3259	Other Chemical Product and Preparation Manufacturing	\$16,028,236	4.88%	\$782,410	\$210,268	\$75.10	0.000%	0.010%
3261	Plastics Product Manufacturing	\$14,344,173	3.88%	\$556,085	\$616,792	\$51.17	0.000%	0.009%
3262	Rubber Product Manufacturing	\$17,847,749	2.28%	\$407,247	\$131,414	\$60.31	0.000%	0.015%
3271	Clay Product and Refractory Manufacturing	\$5,817,784	3.18%	\$184,875	\$104,842	\$67.21	0.001%	0.036%
3272	Glass and Glass Product Manufacturing	\$11,056,358	3.67%	\$405,980	\$192,593	\$91.62	0.001%	0.023%
3273	Cement and Concrete Product Manufacturing	\$6,645,085	5.39%	\$357,912	\$558,111	\$56.02	0.001%	0.016%
3274	Lime and Gypsum Product Manufacturing	\$21,293,052	5.39%	\$1,146,869	\$49,885	\$137.80	0.001%	0.012%

Table V-29
Average Cost Impacts on Establishments Affected by OSHA's Final Revision to Subparts D and I
(per Establishment, by 4-Digit NAICS Code) (continued)

NAICS	Industry	Average Receipts per Estab. [a]	Profit Rate [b]		Estimated Profits per Estab.	Estimated Cost of Final Rule, Annualized with a 7% Discount Rate	Average Annualized Cost per Estab.	Ratio of Average Annualized Cost to Revenues	Ratio of Average Annualized Cost to Profits
3279	Other Nonmetallic Mineral Product Manufacturing	\$5,983,085	4.57%	*	\$273,573	\$191,319	\$54.90	0.001%	0.020%
3311	Iron and Steel Mills and Ferroalloy Manufacturing	\$116,392,537	4.85%		\$5,649,264	\$245,795	\$272.80	0.000%	0.005%
3312	Steel Product Manufacturing from Purchased Steel	\$30,503,973	4.85%	*	\$1,480,550	\$122,082	\$174.65	0.001%	0.012%
3313	Alumina and Aluminum Production and Processing	\$67,170,007	4.74%		\$3,184,968	\$129,730	\$211.98	0.000%	0.007%
3314	Nonferrous Metal (except Aluminum) Production and Processing	\$58,260,176	4.50%	*	\$2,619,617	\$126,197	\$134.54	0.000%	0.005%
3315	Foundries	\$16,145,344	4.70%		\$758,708	\$288,012	\$136.05	0.001%	0.018%
3321	Forging and Stamping	\$12,189,149	4.60%		\$560,163	\$119,720	\$44.94	0.000%	0.008%
3322	Cutlery and Handtool Manufacturing	\$7,448,613	5.17%		\$385,428	\$58,336	\$39.28	0.001%	0.010%
3323	Architectural and Structural Metals Manufacturing	\$6,499,587	4.63%		\$300,661	\$468,074	\$34.15	0.001%	0.011%
3324	Boiler, Tank, and Shipping Container Manufacturing	\$20,030,822	3.69%		\$738,345	\$86,979	\$55.40	0.000%	0.008%
3325	Hardware Manufacturing	\$12,314,210	5.17%	*	\$637,198	\$38,507	\$48.44	0.000%	0.008%
3326	Spring and Wire Product Manufacturing	\$6,348,582	5.17%	*	\$328,507	\$73,028	\$45.25	0.001%	0.014%
3327	Machine Shops; Turned Product; and Screw, Nut, and Bolt Manufacturing	\$2,424,124	5.71%	*	\$138,388	\$698,735	\$27.65	0.001%	0.020%
3328	Coating, Engraving, Heat Treating, and Allied Activities	\$4,307,509	4.59%		\$197,541	\$177,771	\$28.85	0.001%	0.015%
3329	Other Fabricated Metal Product Manufacturing	\$10,708,743	6.76%		\$724,385	\$267,737	\$42.00	0.000%	0.006%
3331	Agriculture, Construction, and Mining Machinery Manufacturing	\$28,804,013	6.07%		\$1,747,589	\$200,080	\$65.30	0.000%	0.004%

NAICS	Industry	Average Receipts per Estab. [a]	Profit Rate [b]	Estimated Profits per Estab.	Estimated Cost of Final Rule, Annualized with a 7% Discount Rate	Average Annualized Cost per Estab.	Ratio of Average Annualized Cost to Revenues	Ratio of Average Annualized Cost to Profits
3332	Industrial Machinery Manufacturing	\$10,319,645	6.27%	\$646,632	\$154,013	\$40.06	0.000%	0.006%
3333	Commercial and Service Industry Machinery Manufacturing	\$10,795,780	4.56%	\$492,388	\$105,495	\$45.95	0.000%	0.009%
3334	Ventilation, Heating, Air-Conditioning, and Commercial Refrigeration Equipment Manufacturing	\$22,423,255	4.26%	\$954,775	\$119,992	\$65.86	0.000%	0.007%
3335	Metalworking Machinery Manufacturing	\$3,631,078	5.10%	\$185,209	\$267,185	\$33.36	0.001%	0.018%
3336	Engine, Turbine, and Power Transmission Equipment Manufacturing	\$45,615,748	2.67%	\$1,217,096	\$83,416	\$89.69	0.000%	0.007%
3339	Other General Purpose Machinery Manufacturing	\$13,746,276	4.94%	\$679,201	\$294,204	\$47.22	0.000%	0.007%
3341	Computer and Peripheral Equipment Manufacturing	\$50,267,032	8.55%	\$4,299,431	\$75,815	\$58.41	0.000%	0.001%
3342	Communications Equipment Manufacturing	\$35,437,387	4.50%	\$1,593,624	\$119,106	\$65.16	0.000%	0.004%
3343	Audio and Video Equipment Manufacturing	\$14,502,526	3.71%	\$537,492	\$19,982	\$37.70	0.000%	0.007%
3344	Semiconductor and Other Electronic Component Manufacturing	\$25,667,299	6.48%	\$1,663,983	\$281,486	\$59.22	0.000%	0.004%
3345	Navigational, Measuring, Electromedical, and Control Instruments Manufacturing	\$25,180,879	5.92%	\$1,491,393	\$306,704	\$58.25	0.000%	0.004%
3346	Manufacturing and Reproducing Magnetic and Optical Media	\$7,704,546	3.71%	\$285,545	\$29,430	\$36.60	0.000%	0.013%
3351	Electric Lighting Equipment Manufacturing	\$11,499,626	4.08%	\$468,646	\$51,269	\$41.92	0.000%	0.009%
3352	Household Appliance Manufacturing	\$68,995,349	4.08%	\$2,811,779	\$62,407	\$178.31	0.000%	0.006%
3353	Electrical Equipment Manufacturing	\$17,529,065	6.93%	\$1,215,171	\$122,133	\$50.74	0.000%	0.004%

Table V-29
Average Cost Impacts on Establishments Affected by OSHA's Final Revision to Subparts D and I
(per Establishment, by 4-Digit NAICS Code) (continued)

NAICS	Industry	Average Receipts per Estab. [a]	Profit Rate [b]		Estimated Profits per Estab.	Estimated Cost of Final Rule, Annualized with a 7% Discount Rate	Average Annualized Cost per Estab.	Ratio of Average Annualized Cost to Revenues	Ratio of Average Annualized Cost to Profits
3359	Other Electrical Equipment and Component Manufacturing	\$23,392,557	5.01%		\$1,172,872	\$119,975	\$55.44	0.000%	0.005%
3361	Motor Vehicle Manufacturing	\$683,670,825	1.09%		\$7,430,421	\$164,166	\$434.30	0.000%	0.006%
3362	Motor Vehicle Body and Trailer Manufacturing	\$16,181,585	1.09%	*	\$175,868	\$122,285	\$55.91	0.000%	0.032%
3363	Motor Vehicle Parts Manufacturing	\$36,411,047	1.09%	*	\$395,731	\$442,003	\$79.99	0.000%	0.020%
3364	Aerospace Product and Parts Manufacturing	\$99,786,959	4.52%		\$4,514,200	\$325,282	\$188.57	0.000%	0.004%
3365	Railroad Rolling Stock Manufacturing	\$58,053,652	2.30%	*	\$1,335,984	\$29,786	\$134.78	0.000%	0.010%
3366	Ship and Boat Building	\$16,100,676	6.14%		\$988,177	\$685,968	\$387.33	0.002%	0.039%
3369	Other Transportation Equipment Manufacturing	\$20,370,353	6.07%		\$1,237,056	\$55,895	\$53.28	0.000%	0.004%
3371	Household and Institutional Furniture and Kitchen Cabinet Manufacturing	\$2,875,210	4.02%	*	\$115,523	\$441,182	\$26.63	0.001%	0.023%
3372	Office Furniture (including Fixtures) Manufacturing	\$6,636,712	4.02%	*	\$266,657	\$151,721	\$36.87	0.001%	0.014%
3379	Other Furniture Related Product Manufacturing	\$9,739,334	4.02%	*	\$391,317	\$38,681	\$37.34	0.000%	0.010%
3391	Medical Equipment and Supplies Manufacturing	\$6,578,304	9.84%		\$647,148	\$378,197	\$31.02	0.000%	0.005%
3399	Other Miscellaneous Manufacturing	\$3,824,768	5.38%		\$205,958	\$517,816	\$27.30	0.001%	0.013%
4231	Motor Vehicle and Motor Vehicle Parts and Supplies Merchant Wholesalers	\$23,332,867	2.25%		\$525,324	\$1,777,741	\$72.46	0.000%	0.014%
4232	Furniture and Home Furnishing Merchant Wholesalers	\$6,230,631	2.74%	*	\$170,702	\$338,606	\$26.72	0.000%	0.016%
4233	Lumber and Other Construction Materials Merchant Wholesalers	\$8,055,209	2.70%		\$217,330	\$969,311	\$49.37	0.001%	0.023%

NAICS	Industry	Average Receipts per Estab. [a]	Profit Rate [b]	Estimated Profits per Estab.	Estimated Cost of Final Rule, Annualized with a 7% Discount Rate	Average Annualized Cost per Estab.	Ratio of Average Annualized Cost to Revenues	Ratio of Average Annualized Cost to Profits
4234	Professional and Commercial Equipment and Supplies Merchant Wholesalers	\$12,095,350	2.66%	\$321,734	\$3,276,410	\$90.72	0.001%	0.028%
4235	Metal and Mineral (except Petroleum) Merchant Wholesalers	\$19,823,622	2.79%	\$553,479	\$382,838	\$35.91	0.000%	0.006%
4236	Electrical and Electronic Goods Merchant Wholesalers	\$14,084,946	2.13%	\$299,857	\$1,679,217	\$57.16	0.000%	0.019%
4237	Hardware, and Plumbing and Heating Equipment and Supplies Merchant Wholesalers	\$6,008,922	3.18%	\$190,871	\$1,164,598	\$57.93	0.001%	0.030%
4238	Machinery, Equipment, and Supplies Merchant Wholesalers	\$7,119,832	3.49%	\$248,387	\$4,130,142	\$69.13	0.001%	0.028%
4239	Miscellaneous Durable Goods Merchant Wholesalers	\$6,872,271	2.74%	\$188,282	\$1,145,514	\$33.21	0.000%	0.018%
4241	Paper and Paper Product Merchant Wholesalers	\$11,244,399	2.02%	\$227,508	\$281,119	\$24.56	0.000%	0.011%
4242	Drugs and Druggists' Sundries Merchant Wholesalers	\$67,598,376	3.42%	\$2,314,303	\$204,212	\$26.70	0.000%	0.001%
4243	Apparel, Piece Goods, and Notions Merchant Wholesalers	\$8,222,667	4.68%	\$385,068	\$292,694	\$18.05	0.000%	0.005%
4244	Grocery and Related Product Wholesalers	\$19,115,018	2.81%	\$537,009	\$1,289,986	\$38.37	0.000%	0.007%
4245	Farm Product Raw Material Merchant Wholesalers	\$20,312,895	2.03%	\$411,623	\$174,787	\$26.62	0.000%	0.006%
4246	Chemical and Allied Products Merchant Wholesalers	\$13,083,132	3.26%	\$426,296	\$529,981	\$42.26	0.000%	0.010%
4247	Petroleum and Petroleum Products Merchant Wholesalers	\$90,011,601	1.90%	\$1,709,053	\$527,052	\$75.04	0.000%	0.004%

Table V-29
Average Cost Impacts on Establishments Affected by OSHA's Final Revision to Subparts D and I
(per Establishment, by 4-Digit NAICS Code) (continued)

NAICS	Industry	Average Receipts per Estab. [a]	Profit Rate [b]		Estimated Profits per Estab.	Estimated Cost of Final Rule, Annualized with a 7% Discount Rate	Average Annualized Cost per Estab.	Ratio of Average Annualized Cost to Revenues	Ratio of Average Annualized Cost to Profits
4248	Beer, Wine, and Distilled Alcoholic Beverage Merchant Wholesalers	\$26,590,428	3.77%		\$1,002,394	\$173,328	\$41.67	0.000%	0.004%
4249	Miscellaneous Nondurable Goods Merchant Wholesalers	\$8,472,012	2.93%		\$248,487	\$755,925	\$24.06	0.000%	0.010%
4251	Wholesale Electronic Markets and Agents and Brokers	\$10,679,245	7.55%	*	\$806,557	\$2,087,749	\$36.96	0.000%	0.005%
4411	Automobile Dealers	\$14,688,872	0.98%		\$143,533	\$4,836,687	\$94.40	0.001%	0.066%
4412	Other Motor Vehicle Dealers	\$3,746,365	2.52%	**	\$94,466	\$674,656	\$39.62	0.001%	0.042%
4413	Automotive Parts, Accessories, and Tire Stores	\$1,352,711	1.24%	*	\$16,800	\$1,953,618	\$33.08	0.002%	0.197%
4421	Furniture Stores	\$2,037,942	3.06%	*	\$62,273	\$651,056	\$22.27	0.001%	0.036%
4422	Home Furnishings Stores	\$1,452,050	3.06%	*	\$44,370	\$1,209,934	\$33.38	0.002%	0.075%
4431	Electronics and Appliance Stores	\$2,211,558	3.29%	*	\$72,720	\$1,980,898	\$37.75	0.002%	0.052%
4441	Building Material and Supplies Dealers	\$4,282,358	7.66%	*	\$328,165	\$3,620,488	\$53.28	0.001%	0.016%
4442	Lawn and Garden Equipment and Supplies Stores	\$2,059,790	1.81%	**	\$37,199	\$622,155	\$30.57	0.001%	0.082%
4451	Grocery Stores	\$5,368,111	2.00%	*	\$107,491	\$1,272,999	\$13.79	0.000%	0.013%
4452	Specialty Food Stores	\$738,448	2.00%	*	\$14,787	\$415,375	\$14.69	0.002%	0.099%
4453	Beer, Wine, and Liquor Stores	\$1,180,880	2.07%	*	\$24,431	\$363,939	\$11.96	0.001%	0.049%
4461	Health and Personal Care Stores	\$2,898,089	3.06%	*	\$88,567	\$1,349,177	\$15.09	0.001%	0.017%
4471	Gasoline Stations	\$3,812,363	0.86%	*	\$32,714	\$3,375,083	\$29.21	0.001%	0.089%
4481	Clothing Stores	\$1,614,743	5.15%	*	\$83,175	\$1,526,162	\$15.37	0.001%	0.018%
4482	Shoe Stores	\$975,601	5.15%	*	\$50,253	\$283,268	\$10.41	0.001%	0.021%
4483	Jewelry, Luggage, and Leather Goods Stores	\$1,103,086	5.15%	*	\$56,820	\$565,222	\$19.60	0.002%	0.035%

Table V-29
Average Cost Impacts on Establishments Affected by OSHA's Final Revision to Subparts D and I
(per Establishment, by 4-Digit NAICS Code) (continued)

NAICS	Industry	Average Receipts per Estab. [a]	Profit Rate [b]		Estimated Profits per Estab.	Estimated Cost of Final Rule, Annualized with a 7% Discount Rate	Average Annualized Cost per Estab.	Ratio of Average Annualized Cost to Revenues	Ratio of Average Annualized Cost to Profits
4511	Sporting Goods, Hobby, and Musical Instrument Stores	\$1,453,174	2.62%	*	\$38,053	\$1,395,992	\$32.08	0.002%	0.084%
4512	Book, Periodical, and Music Stores	\$1,663,461	2.62%	*	\$43,560	\$237,682	\$14.30	0.001%	0.033%
4521	Department Stores	\$28,241,156	4.15%	*	\$1,171,729	\$876,003	\$86.60	0.000%	0.007%
4529	Other General Merchandise Stores	\$8,240,378	4.15%	*	\$341,894	\$1,783,124	\$47.75	0.001%	0.014%
4531	Florists	\$326,775	3.23%	*	\$10,551	\$218,351	\$11.05	0.003%	0.105%
4532	Office Supplies, Stationery, and Gift Stores	\$1,101,750	3.23%	*	\$35,574	\$882,764	\$21.70	0.002%	0.061%
4533	Used Merchandise Stores	\$549,308	3.23%	*	\$17,737	\$293,779	\$16.57	0.003%	0.093%
4539	Other Miscellaneous Store Retailers	\$1,152,691	3.23%	*	\$37,219	\$1,241,751	\$27.47	0.002%	0.074%
4541	Electronic Shopping and Mail-Order Houses	\$10,145,815	3.75%	*	\$380,719	\$352,720	\$21.16	0.000%	0.006%
4542	Vending Machine Operators	\$1,445,311	3.75%	*	\$54,235	\$266,412	\$51.65	0.004%	0.095%
4543	Direct Selling Establishments	\$2,470,427	3.75%	*	\$92,702	\$894,880	\$34.56	0.001%	0.037%
4811	Scheduled Air Transportation	\$41,156,740	2.57%	*	\$1,057,033	\$979,771	\$317.70	0.001%	0.030%
4812	Nonscheduled Air Transportation	\$5,639,505	2.57%	*	\$144,840	\$299,128	\$113.05	0.002%	0.078%
4831	Deep Sea, Coastal, and Great Lakes Water Transportation	\$22,923,786	6.37%	*	\$1,459,344	\$258,929	\$206.32	0.001%	0.014%
4832	Inland Water Transportation	\$8,949,927	6.21%	*	\$555,701	\$216,198	\$321.25	0.004%	0.058%
4841	General Freight Trucking	\$2,164,805	6.21%	*	\$134,413	\$1,974,152	\$28.82	0.001%	0.021%
4842	Specialized Freight Trucking	\$1,396,222	2.51%	*	\$35,106	\$1,321,312	\$24.97	0.002%	0.071%
4851	Urban Transit Systems	\$3,402,520	2.51%	*	\$85,551	\$117,174	\$125.72	0.004%	0.147%
4852	Interurban and Rural Bus Transportation	\$3,260,821	2.13%	*	\$69,439	\$51,697	\$101.77	0.003%	0.147%
4853	Taxi and Limousine Service	\$787,904	2.13%	*	\$16,778	\$172,095	\$22.97	0.003%	0.137%
4854	School and Employee Bus Transportation	\$2,191,238	2.13%	*	\$46,662	\$288,063	\$61.64	0.003%	0.132%
4855	Charter Bus Industry	\$1,761,553	2.13%	*	\$37,512	\$61,874	\$49.62	0.003%	0.132%

Table V-29
Average Cost Impacts on Establishments Affected by OSHA's Final Revision to Subparts D and I
(per Establishment, by 4-Digit NAICS Code) (continued)

NAICS	Industry	Average Receipts per Estab. [a]	Profit Rate [b]		Estimated Profits per Estab.	Estimated Cost of Final Rule, Annualized with a 7% Discount Rate	Average Annualized Cost per Estab.	Ratio of Average Annualized Cost to Revenues	Ratio of Average Annualized Cost to Profits
4859	Other Transit and Ground Passenger Transportation	\$1,103,620	2.13%	*	\$23,502	\$140,085	\$40.38	0.004%	0.172%
4861	Pipeline Transportation of Crude Oil	\$17,279,723	13.23%	*	\$2,286,008	\$64,821	\$173.32	0.001%	0.008%
4862	Pipeline Transportation of Natural Gas	\$14,061,312	13.23%	*	\$1,860,231	\$192,885	\$130.42	0.001%	0.007%
4869	Other Pipeline Transportation	\$8,319,902	13.23%	*	\$1,100,675	\$74,469	\$80.77	0.001%	0.007%
4871	Scenic and Sightseeing Transportation, Land	\$1,294,636	13.23%	*	\$171,273	\$17,600	\$25.22	0.002%	0.015%
4872	Scenic and Sightseeing Transportation, Water	\$756,354	4.42%	*	\$33,457	\$63,716	\$33.89	0.004%	0.101%
4879	Scenic and Sightseeing Transportation, Other	\$1,935,256	4.42%	*	\$85,605	\$10,545	\$51.95	0.003%	0.061%
4881	Support Activities for Air Transportation	\$3,678,342	4.42%	**	\$162,710	\$139,655	\$25.72	0.001%	0.016%
4882	Support Activities for Rail Transportation	\$3,281,636	3.19%	**	\$104,720	\$23,395	\$22.98	0.001%	0.022%
4883	Support Activities for Water Transportation	\$7,071,781	3.19%	**	\$225,667	\$49,775	\$21.36	0.000%	0.009%
4884	Support Activities for Road Transportation	\$699,173	3.19%	**	\$22,311	\$253,255	\$24.88	0.004%	0.112%
4885	Freight Transportation Arrangement	\$2,303,721	3.19%	**	\$73,514	\$400,787	\$22.39	0.001%	0.030%
4889	Other Support Activities for Transportation	\$3,901,796	3.19%	**	\$124,510	\$37,319	\$21.86	0.001%	0.018%
4921	Couriers	\$8,233,275	3.19%	**	\$262,731	\$462,649	\$50.75	0.001%	0.000%
4922	Local Messengers and Local Delivery	\$877,683	3.19%	**	\$28,008	\$84,784	\$17.93	0.002%	0.000%
4931	Warehousing and Storage	\$2,766,702	4.59%	*	\$126,939	\$599,482	\$41.52	0.002%	0.033%
5111	Newspaper, Periodical, Book, and Directory Publishers	\$6,341,521	11.69%	*	\$741,028	\$612,517	\$26.54	0.000%	0.004%
5112	Software Publishers	\$14,921,541	16.22%	*	\$2,420,451	\$398,626	\$47.31	0.000%	0.002%
5121	Motion Picture and Video Industries	\$3,770,904	6.24%	**	\$235,135	\$482,102	\$22.83	0.001%	0.010%

NAICS	Industry	Average Receipts per Estab. [a]	Profit Rate [b]		Estimated Profits per Estab.	Estimated Cost of Final Rule, Annualized with a 7% Discount Rate	Average Annualized Cost per Estab.	Ratio of Average Annualized Cost to Revenues	Ratio of Average Annualized Cost to Profits
5122	Sound Recording Industries	\$3,436,512	7.26%	**	\$249,607	\$231,829	\$61.57	0.002%	0.025%
5151	Radio and Television Broadcasting	\$5,673,895	6.79%	*	\$384,986	\$499,644	\$51.21	0.001%	0.013%
5152	Cable and Other Subscription Programming	\$63,287,418	6.79%	*	\$4,294,186	\$590,753	\$897.80	0.001%	0.021%
5161	Internet Publishing and Broadcasting	\$4,317,762	7.06%	*	\$304,826	\$208,741	\$76.02	0.002%	0.025%
5171	Wired Telecommunications Carriers	\$6,677,530	6.40%	*	\$427,600	\$8,032,878	\$292.69	0.004%	0.068%
5172	Wireless Telecommunications Carriers (except Satellite)	\$14,132,480	6.40%	*	\$904,983	\$990,461	\$83.82	0.001%	0.009%
5173	Telecommunications Resellers	\$4,228,606	6.40%	*	\$270,782	\$664,133	\$194.36	0.005%	0.072%
5174	Satellite Telecommunications	\$8,810,147	6.40%	*	\$564,164	\$331,470	\$468.18	0.005%	0.083%
5175	Cable and Other Program Distribution	\$19,054,522	6.40%	*	\$1,220,169	\$372,083	\$69.86	0.000%	0.006%
5179	Other Telecommunications	\$3,116,634	6.40%	*	\$199,576	\$204,943	\$150.14	0.005%	0.075%
5181	Internet Service Providers and Web Search Portals	\$7,432,832	7.21%	*	\$535,810	\$228,371	\$53.61	0.001%	0.010%
5182	Data Processing, Hosting, and Related Services	\$4,566,208	7.21%	*	\$329,164	\$399,575	\$25.51	0.001%	0.008%
5191	Other Information Services	\$1,719,247	8.78%	*	\$150,944	\$238,707	\$56.47	0.003%	0.037%
5211	Monetary Authorities - Central Bank	\$447,246,115	5.83%	*	\$26,091,558	\$11,359	\$109.22	0.000%	0.000%
5221	Depository Credit Intermediation	\$6,151,846	9.42%	*	\$579,247	\$1,581,993	\$12.44	0.000%	0.002%
5222	Nondepository Credit Intermediation	\$8,390,543	7.53%	*	\$632,208	\$602,292	\$10.25	0.000%	0.002%
5223	Activities Related to Credit Intermediation	\$1,436,047	10.33%	**	\$148,352	\$512,746	\$10.97	0.001%	0.007%
5231	Securities and Commodity Contracts Intermediation and Brokerage	\$10,955,044	5.99%	*	\$655,768	\$460,114	\$11.58	0.000%	0.002%
5232	Securities and Commodity Exchanges	\$12,985,622	5.99%	*	\$777,318	\$10,460	\$26.68	0.000%	0.003%
5239	Other Financial Investment Activities	\$4,369,976	31.09%	*	\$1,358,418	\$526,127	\$10.54	0.000%	0.001%
5241	Insurance Carriers	\$43,422,736	4.56%	*	\$1,981,267	\$559,524	\$16.65	0.000%	0.001%

Table V-29
Average Cost Impacts on Establishments Affected by OSHA's Final Revision to Subparts D and I
(per Establishment, by 4-Digit NAICS Code) (continued)

NAICS	Industry	Average Receipts per Estab. [a]	Profit Rate [b]		Estimated Profits per Estab.	Estimated Cost of Final Rule, Annualized with a 7% Discount Rate	Average Annualized Cost per Estab.	Ratio of Average Annualized Cost to Revenues	Ratio of Average Annualized Cost to Profits
5242	Agencies, Brokerages, and Other Insurance Related Activities	\$1,152,217	4.56%	*	\$52,573	\$1,334,261	\$9.02	0.001%	0.017%
5259	Other Investment Pools and Funds	\$7,004,588	65.69%	*	\$4,601,006	\$70,153	\$19.07	0.000%	0.000%
5311	Lessors of Real Estate	\$1,233,252	13.62%	*	\$167,951	\$2,219,205	\$19.25	0.002%	0.011%
5312	Offices of Real Estate Agents and Brokers	\$825,065	8.22%	*	\$67,809	\$1,317,851	\$11.87	0.001%	0.018%
5313	Activities Related to Real Estate	\$940,128	13.62%	*	\$128,032	\$1,700,427	\$19.72	0.002%	0.015%
5321	Automotive Equipment Rental and Leasing	\$3,353,795	2.43%	**	\$81,615	\$302,029	\$22.41	0.001%	0.027%
5322	Consumer Goods Rental	\$751,790	3.69%	*	\$27,733	\$394,144	\$12.58	0.002%	0.045%
5323	General Rental Centers	\$986,659	3.69%	*	\$36,398	\$90,558	\$16.66	0.002%	0.046%
5324	Commercial and Industrial Machinery and Equipment Rental and Leasing	\$3,384,003	5.35%	**	\$181,106	\$343,243	\$23.20	0.001%	0.013%
5331	Lessors of Nonfinancial Intangible Assets (except Copyrighted Works)	\$8,804,010	29.11%	*	\$2,562,541	\$27,610	\$10.75	0.000%	0.000%
5411	Legal Services	\$1,262,524	8.86%	**	\$111,912	\$2,282,583	\$11.93	0.001%	0.011%
5412	Accounting, Tax Preparation, Bookkeeping, and Payroll Services	\$962,464	7.81%	**	\$75,175	\$1,815,056	\$14.71	0.002%	0.020%
5413	Architectural, Engineering, and Related Services	\$2,185,628	4.79%	**	\$104,584	\$3,377,083	\$28.84	0.001%	0.028%
5414	Specialized Design Services	\$693,485	5.48%	**	\$37,986	\$535,195	\$15.39	0.002%	0.041%
5415	Computer Systems Design and Related Services	\$2,347,291	5.02%	**	\$117,759	\$2,823,557	\$24.18	0.001%	0.021%
5416	Management, Scientific, and Technical Consulting Services	\$1,277,499	7.49%	**	\$95,677	\$3,013,196	\$19.85	0.002%	0.021%
5417	Scientific Research and Development Services	\$6,371,617	2.14%	**	\$136,588	\$1,205,748	\$67.79	0.001%	0.050%

NAICS	Industry	Average Receipts per Estab. [a]	Profit Rate [b]		Estimated Profits per Estab.	Estimated Cost of Final Rule, Annualized with a 7% Discount Rate	Average Annualized Cost per Estab.	Ratio of Average Annualized Cost to Revenues	Ratio of Average Annualized Cost to Profits
5418	Advertising and Related Services	\$2,066,208	5.13%	**	\$106,075	\$16,665,193	\$413.79	0.020%	0.390%
5419	Other Professional, Scientific, and Technical Services	\$872,522	6.72%	**	\$58,646	\$1,000,175	\$13.46	0.002%	0.023%
5511	Management of Companies and Enterprises	\$10,031,243	6.72%	**	\$674,247	\$4,111,304	\$81.18	0.001%	0.012%
5611	Office Administrative Services	\$2,183,588	12.73%	*	\$278,006	\$824,631	\$27.49	0.001%	0.010%
5612	Facilities Support Services	\$4,664,350	4.21%	*	\$196,177	\$306,042	\$66.63	0.001%	0.034%
5613	Employment Services	\$4,382,316	4.21%	**	\$184,315	\$4,696,124	\$105.59	0.002%	0.057%
5614	Business Support Services	\$1,739,445	2.66%	*	\$46,341	\$602,816	\$16.96	0.001%	0.037%
5615	Travel Arrangement and Reservation Services	\$1,876,077	4.21%	**	\$78,905	\$263,715	\$11.82	0.001%	0.015%
5616	Investigation and Security Services	\$1,676,921	3.30%	*	\$55,384	\$1,103,340	\$43.74	0.003%	0.079%
5617	Services to Buildings and Dwellings	\$597,526	4.21%	*	\$25,131	\$93,837,002	\$521.82	0.087%	2.076%
5619	Other Support Services	\$1,881,025	4.21%	*	\$79,114	\$525,654	\$24.94	0.001%	0.032%
5621	Waste Collection	\$3,974,964	5.44%	*	\$216,254	\$314,446	\$31.90	0.001%	0.015%
5622	Waste Treatment and Disposal	\$5,199,269	4.79%	*	\$248,917	\$207,062	\$75.87	0.001%	0.030%
5629	Remediation and Other Waste Management Services	\$1,989,353	4.79%	*	\$95,241	\$335,546	\$37.82	0.002%	0.040%
6111	Elementary and Secondary Schools	\$2,942,534	7.60%	**	\$223,747	\$379,982	\$18.04	0.001%	0.008%
6112	Junior Colleges	\$8,099,367	7.60%	**	\$615,868	\$61,617	\$71.48	0.001%	0.012%
6113	Colleges, Universities, and Professional Schools	\$41,213,603	7.60%	**	\$3,133,842	\$128,977	\$32.07	0.000%	0.001%
6114	Business Schools and Computer and Management Training	\$1,242,548	7.60%	**	\$94,482	\$95,558	\$12.51	0.001%	0.013%
6115	Technical and Trade Schools	\$1,597,997	7.60%	**	\$121,510	\$132,125	\$16.48	0.001%	0.014%
6116	Other Schools and Instruction	\$429,971	7.60%	**	\$32,695	\$425,488	\$11.05	0.003%	0.034%

Table V-29
Average Cost Impacts on Establishments Affected by OSHA's Final Revision to Subparts D and I
(per Establishment, by 4-Digit NAICS Code) (continued)

NAICS	Industry	Average Receipts per Estab. [a]	Profit Rate [b]		Estimated Profits per Estab.	Estimated Cost of Final Rule, Annualized with a 7% Discount Rate	Average Annualized Cost per Estab.	Ratio of Average Annualized Cost to Revenues	Ratio of Average Annualized Cost to Profits
6117	Educational Support Services	\$1,573,883	7.60%	**	\$119,677	\$88,812	\$13.10	0.001%	0.011%
6211	Offices of Physicians	\$1,579,448	4.56%	*	\$71,961	\$2,109,888	\$9.59	0.001%	0.013%
6212	Offices of Dentists	\$741,849	7.66%	*	\$56,811	\$1,213,813	\$9.60	0.001%	0.017%
6213	Offices of Other Health Practitioners	\$418,968	7.78%	*	\$32,616	\$1,074,596	\$8.63	0.002%	0.026%
6214	Outpatient Care Centers	\$2,684,919	5.34%	*	\$143,419	\$393,215	\$13.26	0.000%	0.009%
6215	Medical and Diagnostic Laboratories	\$2,952,598	5.51%	*	\$162,804	\$147,860	\$11.55	0.000%	0.007%
6216	Home Health Care Services	\$2,096,085	5.51%	*	\$115,577	\$272,845	\$11.16	0.001%	0.010%
6219	Other Ambulatory Health Care Services	\$2,925,554	5.51%	*	\$161,313	\$122,287	\$12.98	0.000%	0.008%
6221	General Medical and Surgical Hospitals	\$120,584,628	5.24%	**	\$6,317,681	\$427,496	\$79.11	0.000%	0.001%
6222	Psychiatric and Substance Abuse Hospitals	\$24,937,464	5.24%	**	\$1,306,526	\$30,069	\$41.88	0.000%	0.003%
6223	Specialty (except Psychiatric and Substance Abuse) Hospitals	\$21,388,067	5.24%	**	\$1,120,566	\$37,221	\$30.26	0.000%	0.003%
6231	Nursing Care Facilities	\$5,569,386	5.24%	**	\$291,792	\$222,149	\$12.97	0.000%	0.004%
6232	Residential Mental Retardation, Mental Health and Substance Abuse Facilities	\$785,805	5.24%	**	\$41,170	\$266,780	\$8.45	0.001%	0.021%
6233	Community Care Facilities for the Elderly	\$1,871,515	5.24%	**	\$98,053	\$200,122	\$9.83	0.001%	0.010%
6239	Other Residential Care Facilities	\$1,262,287	5.24%	**	\$66,134	\$64,009	\$9.77	0.001%	0.015%
6241	Individual and Family Services	\$1,088,904	5.24%	**	\$57,050	\$557,436	\$9.66	0.001%	0.017%
6242	Community Food and Housing, and Emergency and Other Relief Services	\$1,629,568	5.24%	**	\$85,376	\$127,891	\$9.33	0.001%	0.011%
6243	Vocational Rehabilitation Services	\$1,589,697	5.24%	**	\$83,288	\$70,917	\$8.97	0.001%	0.011%
6244	Child Day Care Services	\$395,571	5.24%	**	\$20,725	\$557,030	\$7.45	0.002%	0.036%
7111	Performing Arts Companies	\$1,501,694	8.99%	*	\$134,955	\$917,750	\$97.09	0.006%	0.072%
7112	Spectator Sports	\$6,550,026	8.99%	*	\$588,639	\$123,179	\$26.60	0.000%	0.005%

Table V-29
Average Cost Impacts on Establishments Affected by OSHA's Final Revision to Subparts D and I
(per Establishment, by 4-Digit NAICS Code) (continued)

NAICS	Industry	Average Receipts per Estab. [a]	Profit Rate [b]		Estimated Profits per Estab.	Estimated Cost of Final Rule, Annualized with a 7% Discount Rate	Average Annualized Cost per Estab.	Ratio of Average Annualized Cost to Revenues	Ratio of Average Annualized Cost to Profits
7113	Promoters of Performing Arts, Sports, and Similar Events	\$2,484,632	8.99%	*	\$223,289	\$204,843	\$32.17	0.001%	0.014%
7114	Agents and Managers for Artists, Athletes, Entertainers, and Other Public Figures	\$1,290,271	8.99%	*	\$115,954	\$47,060	\$12.64	0.001%	0.011%
7115	Independent Artists, Writers, and Performers	\$664,419	8.99%	*	\$59,710	\$214,595	\$10.68	0.002%	0.018%
7121	Museums, Historical Sites, and Similar Institutions	\$1,780,048	6.69%	**	\$119,016	\$89,021	\$12.17	0.001%	0.010%
7131	Amusement Parks and Arcades	\$4,407,449	4.94%	*	\$217,892	\$71,268	\$23.01	0.001%	0.011%
7132	Gambling Industries	\$11,700,473	4.94%	*	\$578,439	\$40,751	\$14.93	0.000%	0.003%
7139	Other Amusement and Recreation Industries	\$869,292	4.94%	*	\$42,975	\$853,644	\$12.59	0.001%	0.029%
7211	Traveler Accommodation	\$3,116,814	5.14%	*	\$160,221	\$1,859,525	\$34.27	0.001%	0.021%
7212	RV (Recreational Vehicle) Parks and Recreational Camps	\$593,501	5.14%	*	\$30,509	\$104,468	\$14.05	0.002%	0.046%
7213	Rooming and Boarding Houses	\$426,099	5.14%	*	\$21,904	\$27,891	\$12.67	0.003%	0.058%
7221	Full-Service Restaurants	\$875,776	4.61%	*	\$40,338	\$2,084,879	\$9.50	0.001%	0.024%
7222	Limited-Service Eating Places	\$700,332	4.61%	*	\$32,257	\$2,387,440	\$8.95	0.001%	0.028%
7223	Special Food Services	\$1,087,456	4.61%	*	\$50,088	\$723,843	\$20.49	0.002%	0.041%
7224	Drinking Places (Alcoholic Beverages)	\$393,703	4.61%	*	\$18,134	\$448,747	\$9.56	0.002%	0.053%
8111	Automotive Repair and Maintenance	\$538,051	3.25%	*	\$17,494	\$4,428,593	\$26.62	0.005%	0.152%
8112	Electronic and Precision Equipment Repair and Maintenance	\$1,966,318	4.90%	*	\$96,394	\$450,013	\$34.84	0.002%	0.036%
8113	Commercial and Industrial Machinery and Equipment (except Automotive and Electronic) Repair and Maintenance	\$1,333,173	4.90%	*	\$65,355	\$764,001	\$31.97	0.002%	0.049%

Table V-29
Average Cost Impacts on Establishments Affected by OSHA's Final Revision to Subparts D and I
(per Establishment, by 4-Digit NAICS Code) (continued)

NAICS	Industry	Average Receipts per Estab. [a]	Profit Rate [b]	Estimated Profits per Estab.	Estimated Cost of Final Rule, Annualized with a 7% Discount Rate	Average Annualized Cost per Estab.	Ratio of Average Annualized Cost to Revenues	Ratio of Average Annualized Cost to Profits
8114	Personal and Household Goods Repair and Maintenance	\$405,873	4.90% *	\$19,897	\$385,908	\$16.82	0.004%	0.085%
8121	Personal Care Services	\$239,324	5.12% *	\$12,244	\$845,895	\$7.48	0.003%	0.061%
8122	Death Care Services	\$712,650	5.12% *	\$36,460	\$227,795	\$10.63	0.001%	0.029%
8123	Dry-cleaning and Laundry Services	\$601,488	5.12% *	\$30,773	\$538,804	\$13.04	0.002%	0.042%
8129	Other Personal Services	\$511,082	5.12% *	\$26,147	\$509,719	\$13.91	0.003%	0.053%
8131	Religious Organizations	\$698,494	2.05% *	\$14,311	\$1,746,732	\$9.69	0.001%	0.068%
8132	Grantmaking and Giving Services	\$5,741,985	2.05% *	\$117,647	\$187,799	\$11.48	0.000%	0.010%
8133	Social Advocacy Organizations	\$1,228,071	2.05% *	\$25,162	\$189,292	\$12.27	0.001%	0.049%
8134	Civic and Social Organizations	\$623,435	2.05% *	\$12,774	\$440,275	\$14.77	0.002%	0.116%
8139	Business, Professional, Labor, Political, and Similar Organizations	\$1,221,752	2.05% *	\$25,032	\$1,074,364	\$16.87	0.001%	0.067%

[a] Estimated based on receipts data from U.S. Census Bureau, *Statistics of U.S. Businesses, 2007*.

[b] Estimated from average of the yearly ratios of net income to total receipts as reported by the U.S. Internal Revenue Service, *Corporation Source Book, 2000-2008*. Data were not available at disaggregated levels for all industries; OSHA used profit rates at more highly aggregated levels for such industries.

*Profit rate imputed from corresponding 3-digit NAICS industry.

**Profit rate imputed from corresponding 2-digit NAICS industry.

Source: U.S. Department of Labor, OSHA, Directorate of Standards and Guidance, Office of Regulatory Analysis-Safety.

OSHA compared the baseline financial data with total annualized incremental costs of compliance by computing compliance costs as a percentage of revenues and profits. The Agency considers this impact assessment for all firms, presented in Tables V-28 and V-29, to be a screening analysis and the first step in OSHA's analysis of whether the compliance costs potentially associated with the final standards would lead to significant impacts on establishments in the affected industries. The impact of the final standards on the viability of establishments in a given industry depends, to a significant degree, on the price elasticity of demand for the services sold by establishments in that industry.

Price elasticity refers to the relationship between the price charged for a service and the quantity of that service demanded; that is, the more elastic the relationship, the less able is an establishment to pass the costs of compliance through to its customers in the form of a price increase, and the more it will have to absorb the costs of compliance from its profits. When demand is inelastic, establishments can recover most of the costs of compliance by raising the prices they charge for that service; under this scenario, profit rates remain largely unchanged, and the industry remains largely unaffected. Therefore, any impacts are primarily on the consumers using the relevant services. However, when demand is elastic, establishments cannot recover all the costs simply by passing the cost increase through in the form of a price increase. Instead, they must absorb some of the increase from their profits, commonly by both reducing the quantity of goods and services produced and reducing total profits, though, in some cases, profits rate may remain unchanged. If demand is not perfectly elastic and if at least some of the costs in question are variable rather than fixed, "when an industry is subject to a higher cost, it does not simply swallow it, it raises its price and reduces its output, and in this way shifts a part of the cost to its consumers and a part to its suppliers," as the court stated in *American Dental Association v. Secretary of Labor* (984 F.2d 823, 829 (7th Cir. 1993)).

The court's summary is in accordance with micro-economic theory (subject to some caveats discussed below). In the long run, firms can only remain in business if their profits are adequate to provide a return on investment that ensures that investment in the industry will continue. Over time, because of rising real incomes and productivity,

firms in most industries are able to maintain adequate profits. As technology and costs change, however, the long-run demand for some products increases and the long-run demand for other products decreases. In the face of rising external costs, firms that otherwise have a profitable line of business may have to increase prices to stay viable. Commonly, increases in prices result in reduced quantity demanded, but rarely eliminate all demand for the product. Whether this decrease in production results in smaller production for each establishment within the industry or in closing some plants within the industry, or a combination of these two effects, depends on the cost and profit structure of individual firms within the industry.

If demand is completely inelastic (*i.e.*, price elasticity is 0), then the impact of variable compliance costs (that is, costs that depend directly on the quantity of output produced) that are 1 percent of revenues for each firm in the industry would result in a 1 percent increase in the price of the product or service, with no decline in quantity demanded. Such a situation represents an extreme case, but might be correct in situations in which there are few if any substitutes for the product or service in question, or if the products or services of the affected sector account for only a small portion of the income of its consumers.

If demand is perfectly elastic (*i.e.*, the price elasticity is infinitely large), then no increase in price is possible and before-tax profits would decrease by an amount equal to the costs of compliance (minus any savings resulting from improved employee health and/or reduced insurance costs) should the industry attempt to keep producing the same amount of goods and services. Under this scenario, if the costs of compliance are such a large percentage of profits that some or all plants in the industry can no longer invest in the industry and receive an adequate return on investment, then some or all of the firms in the industry will close. The scenario of perfectly elastic demand can only arise when there are other goods and services that are, in the eyes of the consumer, perfect substitutes for the goods and services the affected establishments produce.

A common intermediate case would be a price elasticity of one. In this situation, if the costs of compliance amount to 1 percent of revenues and are entirely variable rather than fixed, then production would decline by 1 percent and prices would rise by 1 percent over the long run. In this case, the industry revenues would stay the same, with somewhat lower production, but with

similar profit rates. However, consumers would get less of the product or the service for their expenditures, and producers would have lower total profits; this, as the court described in *American Dental Association v. Secretary of Labor*, is the more typical case.

If compliance costs are fixed—that is, they do not depend on quantity of output produced—they cannot be passed through to consumers in the short run. In the medium- to long-run, however, some producers may exit the industry, or new producers may fail to enter an industry to replace natural exit, thus decreasing total supply, increasing prices, and reducing the portion of costs borne by producers that remain in the industry (except in the case of perfectly elastic demand, as discussed above).

However, there is still the question of whether these costs will reduce significantly the industry's competitive structure. For example, if an industry faces a 20 percent increase in costs due to a standard, and its product has an elasticity of demand of one, the industry may likely remain viable. However, if the standard leads to closing all small firms in the industry, this result would indicate that standard impaired the competitive structure of the industry. For this reason, when costs are a significant percentage of revenues, OSHA examines the differential costs by size of firm and other classifications that may be important.

As indicated by the impact estimates shown in Tables V-28 and V-29, OSHA determined that, for all affected establishments in general industry, revenue impacts will not exceed 0.2 percent for any affected industry group, and profit impacts will not exceed 3.1 percent for any affected industry group. Therefore, the economic impact of the final rule will most likely consist of a small increase in prices of less than 0.2 percent for the goods and services provided by the affected employers. It is unlikely that a price increase of the magnitude of 0.2 percent will significantly reduce the quantity of goods or services demanded by the public or any other affected customers or intermediaries. If industry can recoup substantially the compliance costs of the final rule with such a minimal increase in prices, there may be little effect on profits.

In general, for most establishments, it would be unlikely that they could not pass some of the compliance costs along in the form of increased prices. In the event that unusual circumstances may inhibit even a price increase of 0.2 percent, profits in the majority of

affected industries would decrease by a maximum of about 0.1 percent.

In profit-earning entities, a combination of increases in prices or reduction in profits generally can absorb compliance costs. As discussed above, the extent to which the impacts of cost increases affect prices or profits depends on the price elasticity of demand for the products or services produced and sold by the entity.

Given the small incremental increases in prices potentially resulting from compliance with the final standards, and the lack of readily available substitutes for the products and services provided by the covered industry sectors, OSHA expects demand to be sufficiently inelastic in each affected industry to enable entities to substantially offset compliance costs through minor price increases without experiencing any significant reduction in total revenues or in net profits.

Positive net benefits of a regulation can only be realized in the presence of an externality or other market failure; until now, society externalized many of the costs associated with the injuries and fatalities resulting from the hazards addressed by the final rule. That is, the prices of goods and services did not reflect the costs incurred by society from the fall-related injuries and death that occur during the production of these goods and services. The workers who suffer the consequences associated with the fall hazards also assume some of the costs of production. To the extent that society externalizes fewer of these costs, the price mechanism will enable the market to produce a more socially efficient allocation of resources. However, reductions in externalities alone do not necessarily increase efficiency or social welfare unless the benefits outweigh the costs of achieving the reductions.

OSHA concludes that compliance with the requirements of the final standards is economically feasible in every affected industry sector. The Agency basis this conclusion on the criteria established by the OSH Act, as interpreted in relevant case law. In general, the courts hold that a standard is economically feasible if there is a reasonable likelihood that the estimated costs of compliance “will not threaten the existence or competitive structure of an industry, even if it does portend disaster for some marginal firms” (*United Steelworkers of America v. Marshall*, 647 F.2d 1189, 1272 (D.C. Cir. 1980)). As demonstrated by this FEA and the supporting evidence, the potential impacts associated with achieving compliance with the final rule

fall well within the bounds of economic feasibility in each industry sector.

OSHA does not expect compliance with the requirements of the final standards to threaten the viability of entities, or the existence or competitive structure of any of the affected industry sectors. In addition, based on an analysis of the costs and economic impacts associated with this rulemaking and the review of the record, OSHA concludes that the effects of the final rule on international trade, employment, wages, and economic growth for the United States would be negligible.

H. Regulatory Flexibility Screening Analysis

1. Introduction

The Regulatory Flexibility Act, as amended in 1996, requires the preparation of a Final Regulatory Flexibility Analysis (FRFA) for any rule that determined to have a significant economic impact on a substantial number of small entities (5 U.S.C. 601–612). Under the provisions of the law, each such analysis must contain:

- A description of the impact of the rule on small entities;
- A statement of the need for, and objectives of, the rule;
- The response of the Agency to any comments filed by the Chief Counsel for Advocacy of the Small Business Administration in response to the proposed rule, and a detailed statement of any revisions made to the proposed rule in the final rule as a result of these comments;
- A statement of the significant issues raised by the public comments in response to the initial regulatory flexibility analysis, a statement of the assessment of the agency of such issues, and a statement of any revisions made in the proposed rule as a result of such comments;
- A description and an estimate of the number of small entities to which the rule will apply, or an explanation of why no such estimate is available;
- A description of the projected reporting, recordkeeping, and other compliance requirements of the rule, including an estimate of the classes of small entities that will be subject to the requirements and the type of professional skills necessary for preparation of the report or record; and
- A description of the steps the agency took in the final rule to minimize the significant economic impact on small entities consistent with the stated objectives of the applicable statutes, including a statement of the factual, policy, and legal reasons for

selecting the alternative adopted in the final rule, and why the agency rejected each of the other significant alternatives to the rule considered by the agency that affect the impact on small entities.

To determine the need for a FRFA, OSHA conducted a regulatory flexibility screening analysis to assess the potential impacts of the proposed standards on affected small entities. On the basis of the screening analysis, presented below, the Assistant Secretary certifies that it does not expect the final standards for walking-working surfaces and personal protective equipment to have a significant impact on a substantial number of small entities.

2. Impact of the Final Rule on Small Entities

Based on the PEA and comments in the rulemaking record, OSHA estimated compliance costs and economic impacts for small entities affected by the final rule. Tables V–2 and V–3 in Section C presented, respectively, the profiles for two classes of general industry entities: Those entities classified as small according to Small Business Administration (SBA) criteria, and those entities with fewer than 20 employees. OSHA assigned costs to small entities by first determining the per-employee compliance costs for those cost items that are a function of the number of affected employees at a facility, and the per-establishment cost for those items that do not vary with establishment size. OSHA then calculated, by industry, the average number of employees for each of the two classes of small entities, multiplied these averages by per-employee compliance cost, and then added the establishment-based cost to determine the average compliance cost for each class of small entity. The Agency then multiplied these average costs by the numbers of small entities to produce the total compliance costs in each industry incurred by small entities.

Table V–30 shows the resultant annualized compliance costs by industry sector for SBA-defined small entities, while Table V–31 shows the costs for entities with fewer than 20 employees. Compliance costs for SBA-defined small entities totaled \$202.6 million, compared to \$305.1 million for all entities. Compliance costs for entities with fewer than 20 employees totaled \$161.6 million.

OSHA calculated the economic impacts of these costs by comparing average compliance costs with average receipts and profits. Tables V–32 and V–33 display the results of these calculations by four-digit NAICS industry sectors; these results are OSHA’s final assessment of impacts on

SBA-defined small entities and entities with fewer than 20 employees (“very small entities”). Among SBA-defined small entities, compliance costs were less than three percent of profits for nearly all industries, and larger than one percent for only two industries: NAICS 2213, Water, Sewage and Other Systems (5.3 percent); and NAICS 5617, Services to Buildings and Dwellings (2.6 percent). For entities with fewer than 20 employees, compliance costs as a percent of profits were less than five percent for nearly all industries, and larger than two percent for only two industries: NAICS 2213, Water, Sewage and Other Systems (11.7 percent); and NAICS 5617, Services to Buildings and Dwellings (4.2 percent).

For one industry group, chimney-cleaning services, found in NAICS 56179, Other Services to Buildings and Dwellings, OSHA estimates that, for the approximately 6,000 establishments providing chimney-cleaning services affected by the final rule, economic impacts could be significant. OSHA estimates that compliance costs could reach 0.6 percent of pre-regulation revenue if the establishments passed all costs forward to customers (primarily

homeowners) or, at the other extreme, costs could approach 15.4 percent of pre-regulation profits if the establishments passed none of the costs forward to customers, but instead absorbed the costs from profits. For several reasons, OSHA believes that demand for chimney-cleaning services is relatively inelastic and, therefore, cost impacts are more likely to result in price adjustments than profit reduction.

On the question of passing compliance costs forward to customers, the National Chimney Sweep Guild noted in a pre-hearing comment:

Unless the homeowner is willing to pay for this added time, then each job becomes less profitable. Furthermore, the additional time required to perform the work would significantly reduce the number of jobs that could be performed per day to the point where the business would have to double its staff to perform the same number of jobs and the business would no longer be profitable. Especially in the current economic climate, homeowners are generally unwilling to absorb these added costs. (Ex. 296, p. 29.)

OSHA disagrees with this comment because, first, all employers providing chimney-cleaning services would face the new requirements at the same time and, therefore, would have few

incentives to hold the price of the services steady at pre-regulation levels with the expectation of gaining enough additional business to offset the compliance costs.

Second, chimney-cleaning services involve almost exclusively domestic American businesses. Therefore, international-trade factors would not present competitive pressures to keep prices at the baseline levels (thereby reducing profits).

Third, under the final rule, in the event that conventional fall protection is infeasible or creates a greater hazard, employers could develop a fall protection plan, the costs of which are likely to be minimal because templates for such plans should be readily available on the Internet. In such cases, employers likely would pass the cost forward to customers.

Finally, OSHA believes the increase in price resulting from the cost increase would be modest. Accordingly, the price increase would not dissuade homeowners from continuing a contractual relationship with chimney-cleaning services.

BILLING CODE 4510-19-P

Table V-30
Compliance Costs for Small Business Entities Affected by OSHA's Final Standards for Subparts D and I (by 2-Digit NAICS)

Annualized Compliance Costs											
NAICS	Industry Sector	§1910.22	§1910.23	§1910.24	§1910.27	§1910.28	§1910.29	§1910.30	Subpart I – Personal Protective Equipment	Rule Familiarization	Total
		General Requirements	Ladders	Step Bolts and Manhole Steps	Scaffolds and Rope Descent Systems	Duty to Have Fall Protection	Fall Protection Systems Criteria and Practices	Training Program			
11	Agriculture, Forestry, Fishing, and Hunting	\$75,555	\$7,446	\$0	\$0	\$0	\$1,715	\$47,567	\$40,885	\$12,109	\$185,277
21	Mining	\$59,092	\$16,841	\$0	\$0	\$44,733	\$336	\$429,312	\$108,529	\$4,727	\$663,570
22	Utilities	\$48,742	\$6,938	\$13,424,305	\$0	\$200,072	\$339	\$122,066	\$64,112	\$4,511	\$13,871,085
31-33	Manufacturing	\$322,494	\$50,874	\$0	\$0	\$2,102,713	\$5,448	\$457,674	\$255,967	\$662,880	\$3,858,051
42	Wholesale Trade	\$3,349,628	\$371,386	\$0	\$0	\$1,284,338	\$41,827	\$5,028,015	\$1,704,499	\$48,279	\$11,827,971
44-45	Retail Trade	\$3,105,583	\$613,478	\$0	\$0	\$1,898,927	\$39,923	\$3,816,793	\$1,805,842	\$145,240	\$11,425,785
48-49	Transportation	\$1,098,774	\$542,998	\$0	\$0	\$698,493	\$33,911	\$1,724,780	\$989,990	\$917,174	\$6,006,120
51	Information	\$567,821	\$395,851	\$47,127	\$0	\$2,032,604	\$12,368	\$5,906,845	\$995,444	\$13,600	\$9,971,660
52	Finance and Insurance	\$731,164	\$106,681	\$0	\$0	\$1,141,954	\$5,218	\$24,526	\$445,224	\$39,767	\$2,494,535
53	Real Estate	\$747,452	\$573,713	\$0	\$0	\$1,536,235	\$9,619	\$1,009,192	\$527,265	\$9,417	\$4,412,892
54	Professional, Scientific, and Technical Services	\$3,666,117	\$505,586	\$0	\$0	\$6,647,887	\$7,594,974	\$2,802,184	\$1,243,441	\$211,830	\$22,672,017
55	Management	\$94,060	\$8,087	\$0	\$0	\$103,300	\$206	\$142,934	\$72,696	\$14,643	\$435,926

Table V-30 Compliance Costs for Small Business Entities Affected by OSHA's Final Standards for Subparts D and I (by 2-Digit NAICS) (continued)											
Annualized Compliance Costs											
NAICS	Industry Sector	\$1910.22 General Requirements	\$1910.23 Ladders	\$1910.24 Step Bolts and Manhole Steps	\$1910.27 Scaffolds and Rope Descent Systems	\$1910.28 Duty to Have Fall Protection	\$1910.29 Fall Protection Systems Criteria and Practices	\$1910.30 Training Program	Subpart I – Personal Protective Equipment	Rule Familiarization	Total
56	Administrative and Support, Waste Management and Remediation Services	\$1,144,497	\$322,456	\$0	\$68,752,074	\$18,796,713	\$12,686	\$2,149,143	\$516,112	\$142,534	\$91,836,215
61	Educational Services	\$330,318	\$79,334	\$0	\$0	\$338,081	\$4,428	\$16,866	\$87,246	\$108,826	\$965,099
62	Health Care	\$2,129,746	\$262,302	\$0	\$0	\$2,426,089	\$39,935	\$95,903	\$600,735	\$107,778	\$5,662,488
71	Arts, Entertainment, and Recreation	\$474,730	\$133,040	\$47,438	\$0	\$1,393,096	\$6,154	\$15,432	\$113,316	\$97,065	\$2,280,271
72	Accommodation and Food Services	\$1,646,380	\$238,887	\$0	\$0	\$1,467,974	\$26,664	\$683,389	\$587,747	\$36,906	\$4,687,946
81	Other Services	\$2,455,900	\$1,025,781	\$0	\$0	\$2,595,068	\$36,028	\$2,245,884	\$948,318	\$54,486	\$9,361,465
Total		\$22,048,051	\$5,261,679	\$13,518,870	\$68,752,074	\$44,708,275	\$7,871,777	\$26,718,506	\$11,107,367	\$2,631,772	\$202,618,373

Source: U.S. Department of Labor, OSHA, Directorate of Standards and Guidance, Office of Regulatory Analysis-Safety.

Table V-31
Compliance Costs for Very Small Business Entities (Fewer than 20 Employees) Affected by OSHA's Final Standards
for Subparts D and I
(by 2-Digit NAICS)

Annualized Compliance Costs											
NAICS	Industry Sector	§1910.22 General Requirements	§1910.23 Ladders	§1910.24 Step Bolts and Manhole Steps	§1910.27 Scaffolds and Rope Descent Systems	§1910.28 Duty to Have Fall Protection	§1910.29 Fall Protection Systems Criteria and Practices	§1910.30 Training Program	Subpart I – Personal Protective Equipment	Rule Familiarization	Total
11	Agriculture, Forestry, Fishing, and Hunting	\$72,203	\$5,263	\$0	\$0	\$0	\$1,216	\$33,309	\$37,252	\$11,508	\$160,749
21	Mining	\$53,442	\$7,388	\$0	\$0	\$40,456	\$147	\$188,344	\$65,109	\$4,275	\$359,161
22	Utilities	\$37,746	\$5,673	\$12,735,080	\$0	\$183,559	\$323	\$94,240	\$45,047	\$3,696	\$13,105,363
31-33	Manufacturing	\$254,924	\$8,897	\$0	\$0	\$630,179	\$976	\$73,912	\$164,962	\$516,440	\$1,650,288
42	Wholesale Trade	\$2,941,272	\$179,044	\$0	\$0	\$1,126,862	\$20,752	\$2,396,338	\$1,126,039	\$40,629	\$7,830,936
44-45	Retail Trade	\$2,781,933	\$404,161	\$0	\$0	\$1,701,622	\$26,330	\$2,449,700	\$1,509,492	\$130,567	\$9,003,805
48-49	Transportation	\$1,000,293	\$219,188	\$0	\$0	\$646,898	\$14,259	\$444,013	\$832,076	\$752,653	\$3,909,381
51	Information	\$496,930	\$30,565	\$42,015	\$0	\$1,803,063	\$1,953	\$242,619	\$128,425	\$12,248	\$2,757,819
52	Finance and Insurance	\$1,165,870	\$126,595	\$0	\$0	\$1,888,291	\$5,803	\$181,413	\$858,438	\$36,682	\$4,263,092
53	Real Estate	\$673,968	\$272,122	\$0	\$0	\$1,320,164	\$5,282	\$607,848	\$484,887	\$8,645	\$3,372,916
54	Professional, Scientific, and Technical Services	\$3,347,380	\$257,471	\$0	\$0	\$4,221,593	\$1,088,569	\$1,829,663	\$1,114,558	\$198,782	\$12,058,016
55	Management	\$25,870	\$768	\$0	\$0	\$28,411	\$20	\$13,565	\$16,387	\$4,027	\$89,046

Table V-31 Compliance Costs for Very Small Business Entities (Fewer than 20 Employees) Affected by OSHA's Final Standards for Subparts D and I (by 2-Digit NAICS) (continued)											
Annualized Compliance Costs											
NAICS	Industry Sector	§1910.22 General Requirements	§1910.23 Ladders	§1910.24 Step Bolts and Manhole Steps	§1910.27 Scaffolds and Rope Descent Systems	§1910.28 Duty to Have Fall Protection	§1910.29 Fall Protection Systems Criteria and Practices	§1910.30 Training Program	Subpart I – Personal Protective Equipment	Rule Familiarization	Total
56	Administrative and Support, Waste Management and Remediation Services	\$1,013,294	\$144,580	\$0	\$63,961,723	\$17,438,527	\$6,664	\$1,024,149	\$359,357	\$122,048	\$84,070,342
61	Educational Services	\$268,560	\$23,608	\$0	\$0	\$270,800	\$2,038	\$2,674	\$67,844	\$83,001	\$718,525
62	Health Care	\$1,870,417	\$161,644	\$0	\$0	\$2,146,925	\$24,750	\$23,072	\$494,656	\$83,261	\$4,804,725
71	Arts, Entertainment, and Recreation	\$413,898	\$53,175	\$42,783	\$0	\$1,219,682	\$2,788	\$5,671	\$97,859	\$87,676	\$1,923,532
72	Accommodation and Food Services	\$1,313,863	\$92,945	\$0	\$0	\$1,174,721	\$10,269	\$264,755	\$440,448	\$31,859	\$3,328,860
81	Other Services	\$2,309,512	\$788,129	\$0	\$0	\$2,437,663	\$29,298	\$1,769,636	\$835,344	\$52,104	\$8,221,687
	Total	\$20,041,375	\$2,781,217	\$12,819,878	\$63,961,723	\$38,279,415	\$1,241,436	\$11,644,922	\$8,678,181	\$2,180,100	\$161,628,246

Source: U.S. Department of Labor, OSHA, Directorate of Standards and Guidance, Office of Regulatory Analysis-Safety.

Table V-32
Average Cost Impacts on Small Business Entities Affected by OSHA's Final Standards for Subparts D and I
(per Entity, by 4-Digit NAICS Code)

NAICS	Industry	SBA Employment Size Criterion [a]	Estimated Receipts, 2007 (\$1,000)[b]	Entities [c]	Average Receipts per Entity	Profit Rate [d]	Estimated Profits per Entity	Estimated Cost of the Final Rule	Average Cost per Entity	Ratio of Average Cost to Revenues	Ratio of Average Cost to Profits
1131	Timber Tract Operations	500	\$468,335	389	\$1,203,946	3.46%	\$41,699	\$3,638	\$9.35	0.001%	0.022%
1132	Forest Nurseries and Gathering of Forest Products	500	\$165,443	169	\$978,953	3.46%	\$33,906	\$1,772	\$10.49	0.001%	0.031%
1133	Logging	500	\$9,576,634	9,714	\$985,859	3.46%	\$34,145	\$139,577	\$14.37	0.001%	0.042%
1141	Fishing	20	\$2,184,360	2,039	\$1,071,290	5.50%	\$58,882	\$19,368	\$9.50	0.001%	0.016%
1142	Hunting and Trapping	20	\$224,921	323	\$696,350	5.50%	\$38,274	\$3,080	\$9.54	0.001%	0.025%
1153	Support Activities for Forestry	100	\$1,005,318	1,641	\$612,625	4.60%	\$28,179	\$18,845	\$11.48	0.002%	0.041%
2111	Oil and Gas Extraction	500	\$65,881,686	6,453	\$10,209,466	13.95%	\$1,424,662	\$667,011	\$103.36	0.001%	0.007%
2211	Electric Power Generation, Transmission and Distribution	20	\$71,561,117	1,551	\$46,138,696	4.33%	\$1,998,003	\$408,472	\$263.36	0.001%	0.013%
2212	Natural Gas Distribution	20	\$26,658,582	441	\$60,450,299	3.12%	\$1,888,167	\$29,221	\$66.26	0.000%	0.004%
2213	Water, Sewage and Other Systems	100	\$4,692,243	3,918	\$1,197,612	5.44%	\$65,140	\$13,436,129	\$3,429.33	0.286%	5.265%
3111	Animal Food Manufacturing	500	\$13,482,404	1,173	\$11,493,951	4.28%	\$491,520	\$177,057	\$150.94	0.001%	0.031%
3112	Grain and Oilseed Milling	500	\$12,159,386	461	\$26,376,108	4.28%	\$1,127,932	\$82,017	\$177.91	0.001%	0.016%

Table V-32
Average Cost Impacts on Small Business Entities Affected by OSHA's Final Revision to Subparts D and I
(per Entity, by 4-Digit NAICS Code)

NAICS	Industry	SBA Employment Size Criterion [a]	Estimated Receipts, 2007 (\$1,000)[b]	Entities [c]	Average Receipts per Entity	Profit Rate [d]	Estimated Profits per Entity	Estimated Cost of the Final Rule	Average Cost per Entity	Ratio of Average Cost to Revenues	Ratio of Average Cost to Profits
3113	Sugar and Confectionery Product Manufacturing	500	\$7,534,539	1,587	\$4,747,662	7.74%	\$367,409	\$82,769	\$52.15	0.001%	0.014%
3114	Fruit and Vegetable Preserving and Specialty Food Manufacturing	500	\$22,320,630	1,221	\$18,280,614	6.70%	\$1,224,283	\$57,621	\$47.19	0.000%	0.004%
3115	Dairy Product Manufacturing	500	\$22,955,544	1,031	\$22,265,319	2.60%	\$578,977	\$53,560	\$51.95	0.000%	0.009%
3116	Animal Slaughtering and Processing	500	\$35,753,664	3,109	\$11,500,053	2.15%	\$247,280	\$1,822,315	\$586.14	0.005%	0.237%
3117	Seafood Product Preparation and Packaging	500	\$5,841,258	574	\$10,176,408	2.15% *	\$218,819	\$18,060	\$31.46	0.000%	0.014%
3118	Bakeries and Tortilla Manufacturing	500	\$16,114,228	9,408	\$1,712,822	8.78%	\$150,370	\$457,061	\$48.58	0.003%	0.032%
3119	Other Food Manufacturing	500	\$27,225,372	2,761	\$9,860,693	5.36%	\$528,799	\$115,780	\$41.93	0.000%	0.008%
3121	Beverage Manufacturing	500	\$19,574,647	3,338	\$5,864,184	6.67% *	\$391,223	\$160,069	\$47.95	0.001%	0.012%
3122	Tobacco Manufacturing	500	\$1,445,606	72	\$20,077,861	17.89%	\$3,590,997	\$11,689	\$162.35	0.001%	0.005%
3131	Fiber, Yarn, and Thread Mills	500	\$1,981,174	281	\$7,063,009	3.45% *	\$243,562	\$18,183	\$64.82	0.001%	0.027%
3132	Fabric Mills	500	\$8,428,933	1,107	\$7,614,212	3.45% *	\$262,569	\$37,323	\$33.72	0.000%	0.013%

Table V-32
Average Cost Impacts on Small Business Entities Affected by OSHA's Final Revision to Subparts D and I
(per Entity, by 4-Digit NAICS Code)

NAICS	Industry	SBA Employment Size Criterion [a]	Estimated Receipts, 2007 (\$1,000)[b]	Entities [c]	Average Receipts per Entity	Profit Rate [d]	Estimated Profits per Entity	Estimated Cost of the Final Rule	Average Cost per Entity	Ratio of Average Cost to Revenues	Ratio of Average Cost to Profits
3133	Textile and Fabric Finishing and Fabric Coating Mills	500	\$6,016,388	1,259	\$4,778,704	3.45% *	\$164,789	\$118,792	\$94.35	0.002%	0.057%
3141	Textile Furnishings Mills	500	\$4,609,735	2,418	\$1,906,425	3.68% *	\$70,074	\$208,222	\$86.11	0.005%	0.123%
3149	Other Textile Product Mills	500	\$7,523,532	3,994	\$1,883,709	3.68% *	\$69,239	\$187,312	\$46.90	0.002%	0.068%
3151	Apparel Knitting Mills	500	\$1,531,845	433	\$3,537,748	2.87%	\$101,524	\$64,182	\$148.23	0.004%	0.146%
3152	Cut and Sew Apparel Manufacturing	500	\$18,921,683	8,772	\$2,157,055	5.00%	\$107,768	\$142,692	\$16.27	0.001%	0.015%
3159	Apparel Accessories and Other Apparel Manufacturing	500	\$1,296,347	884	\$1,466,456	3.92%	\$57,491	\$17,903	\$20.25	0.001%	0.035%
3161	Leather and Hide Tanning and Finishing	500	\$962,480	230	\$4,184,696	5.36% *	\$224,115	\$7,399	\$32.17	0.001%	0.014%
3162	Footwear Manufacturing	500	\$708,810	274	\$2,586,898	5.36% *	\$138,544	\$8,587	\$31.34	0.001%	0.023%
3169	Other Leather and Allied Product Manufacturing	500	\$1,865,997	821	\$2,272,834	5.36% *	\$121,724	\$15,343	\$18.69	0.001%	0.015%
3211	Sawmills and Wood Preservation	500	\$18,421,888	3,662	\$5,030,554	2.86% *	\$144,087	\$117,626	\$32.12	0.001%	0.022%
3212	Veneer, Plywood, and Engineered Wood Product Manufacturing	500	\$9,105,606	1,444	\$6,305,821	2.86% *	\$180,614	\$65,612	\$45.44	0.001%	0.025%
3219	Other Wood Product Manufacturing	500	\$30,432,601	9,405	\$3,235,790	2.86% *	\$92,681	\$277,993	\$29.56	0.001%	0.032%
3221	Pulp, Paper, and Paperboard Mills	750	\$7,736,635	217	\$35,652,696	3.36%	\$1,197,661	\$171,900	\$792.17	0.002%	0.066%

NAICS	Industry	SBA Employment Size Criterion [a]	Estimated Receipts, 2007 (\$1,000)[b]	Entities [c]	Average Receipts per Entity	Profit Rate [d]	Estimated Profits per Entity	Estimated Cost of the Final Rule	Average Cost per Entity	Ratio of Average Cost to Revenues	Ratio of Average Cost to Profits
3222	Converted Paper Product Manufacturing	750	\$36,539,855	2,941	\$12,426,409	7.61%	\$945,481	\$426,427	\$145.02	0.001%	0.015%
3231	Printing and Related Support Activities	500	\$58,682,825	31,414	\$1,868,047	3.99% *	\$74,506	\$727,802	\$23.17	0.001%	0.031%
3241	Petroleum and Coal Products Manufacturing	500	\$48,140,351	1,096	\$43,923,678	7.34% *	\$3,222,320	\$167,276	\$152.62	0.000%	0.005%
3251	Basic Chemical Manufacturing	500	\$49,507,084	1,290	\$38,377,584	4.32%	\$1,657,316	\$165,598	\$128.37	0.000%	0.008%
3252	Resin, Synthetic Rubber, and Artificial Synthetic Fibers and Filaments Manufacturing	500	\$20,518,018	685	\$29,953,311	7.67%	\$2,297,000	\$279,299	\$407.74	0.001%	0.018%
3253	Pesticide, Fertilizer, and Other Agricultural Chemical Manufacturing	500	\$6,412,264	633	\$10,129,959	10.59% *	\$1,073,008	\$63,493	\$100.30	0.001%	0.009%
3254	Pharmaceutical and Medicine Manufacturing	500	\$21,206,858	1,385	\$15,311,811	15.76%	\$2,413,810	\$103,922	\$75.03	0.000%	0.003%
3255	Paint, Coating, and Adhesive Manufacturing	500	\$10,450,584	1,446	\$7,227,237	5.06%	\$365,419	\$61,518	\$42.54	0.001%	0.012%
3256	Soap, Cleaning Compound, and Toilet Preparation Manufacturing	500	\$20,115,249	1,938	\$10,379,385	9.72%	\$1,008,822	\$114,669	\$59.17	0.001%	0.006%

Table V-32
Average Cost Impacts on Small Business Entities Affected by OSHA's Final Revision to Subparts D and I
(per Entity, by 4-Digit NAICS Code)

NAICS	Industry	SBA Employment Size Criterion [a]	Estimated Receipts, 2007 (\$1,000)[b]	Entities [c]	Average Receipts per Entity	Profit Rate [d]	Estimated Profits per Entity	Estimated Cost of the Final Rule	Average Cost per Entity	Ratio of Average Cost to Revenues	Ratio of Average Cost to Profits
3259	Other Chemical Product and Preparation Manufacturing	500	\$14,882,426	2,068	\$7,196,531	4.88%	\$351,295	\$111,380	\$53.86	0.001%	0.015%
3261	Plastics Product Manufacturing	500	\$74,870,708	9,146	\$8,186,170	3.88%	\$317,356	\$361,097	\$39.48	0.000%	0.012%
3262	Rubber Product Manufacturing	500	\$13,874,745	1,628	\$8,522,571	2.28%	\$194,467	\$63,085	\$38.75	0.000%	0.020%
3271	Clay Product and Refractory Manufacturing	500	\$4,378,014	1,304	\$3,357,373	3.18%	\$106,689	\$60,813	\$46.64	0.001%	0.044%
3272	Glass and Glass Product Manufacturing	500	\$5,294,032	1,726	\$3,067,226	3.67%	\$112,626	\$82,989	\$48.08	0.002%	0.043%
3273	Cement and Concrete Product Manufacturing	500	\$33,888,989	5,020	\$6,750,795	5.39%	\$363,606	\$308,718	\$61.50	0.001%	0.017%
3274	Lime and Gypsum Product Manufacturing	500	\$1,384,991	202	\$6,856,391	5.39% *	\$369,293	\$17,215	\$85.22	0.001%	0.023%
3279	Other Nonmetallic Mineral Product Manufacturing	500	\$9,176,165	2,937	\$3,124,333	4.57% *	\$142,858	\$134,955	\$45.95	0.001%	0.032%
3311	Iron and Steel Mills and Ferroalloy Manufacturing	750	\$18,680,495	730	\$25,589,719	4.85%	\$1,242,030	\$195,786	\$268.20	0.001%	0.022%
3312	Steel Product Manufacturing from Purchased Steel	1000	\$11,597,089	497	\$23,334,183	4.85% *	\$1,132,555	\$100,911	\$203.04	0.001%	0.018%

Table V-32
Average Cost Impacts on Small Business Entities Affected by OSHA's Final Revision to Subparts D and I
(per Entity, by 4-Digit NAICS Code)

NAICS	Industry	SBA Employment Size Criterion [a]	Estimated Receipts, 2007 (\$1,000)[b]	Entities [c]	Average Receipts per Entity	Profit Rate [d]	Estimated Profits per Entity	Estimated Cost of the Final Rule	Average Cost per Entity	Ratio of Average Cost to Revenues	Ratio of Average Cost to Profits
3313	Alumina and Aluminum Production and Processing	750	\$9,481,337	421	\$22,520,990	4.74%	\$1,067,867	\$99,216	\$235.67	0.001%	0.022%
3314	Nonferrous Metal (except Aluminum) Production and Processing	750	\$16,396,272	676	\$24,254,840	4.50% *	\$1,090,597	\$92,323	\$136.57	0.001%	0.013%
3315	Foundries	500	\$17,218,659	1,796	\$9,587,227	4.70%	\$450,527	\$153,234	\$85.32	0.001%	0.019%
3321	Forging and Stamping	500	\$21,580,191	2,301	\$9,378,614	4.60%	\$431,002	\$90,443	\$39.31	0.000%	0.009%
3322	Cutlery and Handtool Manufacturing	500	\$6,243,986	1,333	\$4,684,161	5.17%	\$242,382	\$43,863	\$32.91	0.001%	0.014%
3323	Architectural and Structural Metals Manufacturing	500	\$58,158,410	12,517	\$4,646,354	4.63%	\$214,933	\$380,218	\$30.38	0.001%	0.014%
3324	Boiler, Tank, and Shipping Container Manufacturing	500	\$10,822,634	1,214	\$8,914,855	3.69%	\$328,605	\$51,547	\$42.46	0.000%	0.013%
3325	Hardware Manufacturing	500	\$4,402,513	673	\$6,541,624	5.17% *	\$338,496	\$24,733	\$36.75	0.001%	0.011%
3326	Spring and Wire Product Manufacturing	500	\$6,481,270	1,395	\$4,646,072	5.17% *	\$240,411	\$59,605	\$42.73	0.001%	0.018%
3327	Machine Shops; Turned Product; and Screw, Nut, and Bolt Manufacturing	500	\$50,649,664	24,638	\$2,055,754	5.71% *	\$117,359	\$662,763	\$26.90	0.001%	0.023%
3328	Coating, Engraving, Heat Treating, and Allied Activities	500	\$19,921,419	5,526	\$3,605,034	4.59%	\$165,326	\$155,507	\$28.14	0.001%	0.017%

Table V-32
Average Cost Impacts on Small Business Entities Affected by OSHA's Final Revision to Subparts D and I
(per Entity, by 4-Digit NAICS Code)

NAICS	Industry	SBA Employment Size Criterion [a]	Estimated Receipts, 2007 (\$1,000)[b]	Entities [c]	Average Receipts per Entity	Profit Rate [d]	Estimated Profits per Entity	Estimated Cost of the Final Rule	Average Cost per Entity	Ratio of Average Cost to Revenues	Ratio of Average Cost to Profits
3329	Other Fabricated Metal Product Manufacturing	500	\$28,666,675	5,625	\$5,096,298	6.76%	\$344,735	\$179,844	\$31.97	0.001%	0.009%
3331	Agriculture, Construction, and Mining Machinery Manufacturing	500	\$24,737,429	2,640	\$9,370,238	6.07%	\$568,508	\$113,707	\$43.07	0.000%	0.008%
3332	Industrial Machinery Manufacturing	500	\$17,768,488	3,510	\$5,062,247	6.27%	\$317,202	\$120,147	\$34.23	0.001%	0.011%
3333	Commercial and Service Industry Machinery Manufacturing	500	\$10,377,208	2,013	\$5,155,096	4.56%	\$235,120	\$72,958	\$36.24	0.001%	0.015%
3334	Ventilation, Heating, Air-Conditioning, and Commercial Refrigeration Equipment Manufacturing	500	\$10,739,286	1,397	\$7,687,392	4.26%	\$327,327	\$54,324	\$38.89	0.001%	0.012%
3335	Metalworking Machinery Manufacturing	500	\$20,422,820	7,595	\$2,688,982	5.10%	\$137,156	\$239,486	\$31.53	0.001%	0.023%
3336	Engine, Turbine, and Power Transmission Equipment Manufacturing	500	\$7,115,536	704	\$10,107,295	2.67%	\$269,678	\$30,341	\$43.10	0.000%	0.016%
3339	Other General Purpose Machinery Manufacturing	500	\$33,262,361	5,361	\$6,204,507	4.94%	\$306,563	\$189,510	\$35.35	0.001%	0.012%

Table V-32
Average Cost Impacts on Small Business Entities Affected by OSHA's Final Revision to Subparts D and I
(per Entity, by 4-Digit NAICS Code)

NAICS	Industry	SBA Employment Size Criterion [a]	Estimated Receipts, 2007 (\$1,000)[b]	Entities [c]	Average Receipts per Entity	Profit Rate [d]	Estimated Profits per Entity	Estimated Cost of the Final Rule	Average Cost per Entity	Ratio of Average Cost to Revenues	Ratio of Average Cost to Profits
3341	Computer and Peripheral Equipment Manufacturing	1,000	\$10,655,606	1,184	\$8,999,667	8.55%	\$769,758	\$69,111	\$58.37	0.001%	0.008%
3342	Communications Equipment Manufacturing	750	\$15,471,516	1,517	\$10,202,121	4.50%	\$458,791	\$92,625	\$61.08	0.001%	0.013%
3343	Audio and Video Equipment Manufacturing	750	\$3,407,537	496	\$6,870,034	3.71%	\$254,617	\$18,776	\$37.85	0.001%	0.015%
3344	Semiconductor and Other Electronic Component Manufacturing	500	\$29,325,434	4,039	\$7,260,568	6.48%	\$470,695	\$159,175	\$39.41	0.001%	0.008%
3345	Navigational, Measuring, Electromedical, and Control Instruments Manufacturing	500	\$32,498,798	4,395	\$7,395,335	5.92%	\$438,005	\$146,103	\$33.25	0.000%	0.008%
3346	Manufacturing and Reproducing Magnetic and Optical Media	500	\$2,180,159	750	\$2,906,879	3.71% *	\$107,735	\$21,226	\$28.30	0.001%	0.026%
3351	Electric Lighting Equipment Manufacturing	500	\$7,317,724	1,102	\$6,643,417	4.08%	\$270,740	\$36,167	\$32.83	0.000%	0.012%
3352	Household Appliance Manufacturing	500	\$1,896,622	279	\$6,797,928	4.08%	\$277,037	\$28,767	\$103.11	0.002%	0.037%
3353	Electrical Equipment Manufacturing	500	\$13,308,052	1,971	\$6,751,929	6.93%	\$468,065	\$97,933	\$49.69	0.001%	0.011%

Table V-32
Average Cost Impacts on Small Business Entities Affected by OSHA's Final Revision to Subparts D and I
(per Entity, by 4-Digit NAICS Code)

NAICS	Industry	SBA Employment Size Criterion [a]	Estimated Receipts, 2007 (\$1,000)[b]	Entities [c]	Average Receipts per Entity	Profit Rate [d]	Estimated Profits per Entity	Estimated Cost of the Final Rule	Average Cost per Entity	Ratio of Average Cost to Revenues	Ratio of Average Cost to Profits
3359	Other Electrical Equipment and Component Manufacturing	500	\$21,773,278	1,743	\$12,491,840	5.01%	\$626,324	\$70,267	\$40.31	0.000%	0.006%
3361	Motor Vehicle Manufacturing	1,000	\$4,735,259	276	\$17,156,736	1.09%	\$186,467	\$148,429	\$537.79	0.003%	0.288%
3362	Motor Vehicle Body and Trailer Manufacturing	500	\$15,196,178	1,851	\$8,209,713	1.09% *	\$89,227	\$71,247	\$38.49	0.000%	0.043%
3363	Motor Vehicle Parts Manufacturing	500	\$55,365,541	4,227	\$13,098,070	1.09% *	\$142,355	\$180,026	\$42.59	0.000%	0.030%
3364	Aerospace Product and Parts Manufacturing	1,000	\$13,091,579	1,275	\$10,267,905	4.52%	\$464,503	\$283,376	\$222.26	0.002%	0.048%
3365	Railroad Rolling Stock Manufacturing	1,000	\$1,508,526	141	\$10,698,766	2.30% *	\$246,210	\$22,754	\$161.38	0.002%	0.066%
3366	Ship and Boat Building	500	\$11,479,976	1,612	\$7,121,573	6.14%	\$437,085	\$230,217	\$142.81	0.002%	0.033%
3369	Other Transportation Equipment Manufacturing	500	\$5,488,371	986	\$5,566,299	6.07%	\$338,032	\$38,221	\$38.76	0.001%	0.011%
3371	Household and Institutional Furniture and Kitchen Cabinet Manufacturing	500	\$25,553,757	16,089	\$1,588,275	4.02% *	\$63,815	\$368,702	\$22.92	0.001%	0.036%
3372	Office Furniture (including Fixtures) Manufacturing	500	\$15,486,586	3,866	\$4,005,842	4.02% *	\$160,951	\$122,548	\$31.70	0.001%	0.020%

Table V-32
Average Cost Impacts on Small Business Entities Affected by OSHA's Final Revision to Subparts D and I
(per Entity, by 4-Digit NAICS Code)

NAICS	Industry	SBA Employment Size Criterion [a]	Estimated Receipts, 2007 (\$1,000)[b]	Entities [c]	Average Receipts per Entity	Profit Rate [d]	Estimated Profits per Entity	Estimated Cost of the Final Rule	Average Cost per Entity	Ratio of Average Cost to Revenues	Ratio of Average Cost to Profits
3379	Other Furniture Related Product Manufacturing	500	\$5,000,204	888	\$5,630,860	4.02% *	\$226,243	\$27,325	\$30.77	0.001%	0.014%
3391	Medical Equipment and Supplies Manufacturing	500	\$28,982,721	11,227	\$2,581,520	9.84%	\$253,960	\$285,223	\$25.41	0.001%	0.010%
3399	Other Miscellaneous Manufacturing	500	\$43,667,832	18,259	\$2,391,579	5.38%	\$128,783	\$454,148	\$24.87	0.001%	0.019%
4231	Motor Vehicle and Motor Vehicle Parts and Supplies Merchant Wholesalers	100	\$88,349,621	16,942	\$5,214,828	2.25%	\$117,408	\$894,270	\$52.78	0.001%	0.045%
4232	Furniture and Home Furnishing Merchant Wholesalers	100	\$57,631,397	10,468	\$5,505,483	2.74% *	\$150,835	\$248,336	\$23.72	0.000%	0.016%
4233	Lumber and Other Construction Materials Merchant Wholesalers	100	\$61,158,220	12,190	\$5,017,184	2.70%	\$135,364	\$512,225	\$42.02	0.001%	0.031%
4234	Professional and Commercial Equipment and Supplies Merchant Wholesalers	100	\$99,564,895	25,371	\$3,924,436	2.66%	\$104,389	\$1,261,769	\$49.73	0.001%	0.048%
4235	Metal and Mineral (except Petroleum) Merchant Wholesalers	100	\$79,191,947	6,957	\$11,382,651	2.79%	\$317,806	\$217,881	\$31.32	0.000%	0.010%

Table V-32
Average Cost Impacts on Small Business Entities Affected by OSHA's Final Revision to Subparts D and I
(per Entity, by 4-Digit NAICS Code)

NAICS	Industry	SBA Employment Size Criterion [a]	Estimated Receipts, 2007 (\$1,000)[b]	Entities [c]	Average Receipts per Entity	Profit Rate [d]	Estimated Profits per Entity	Estimated Cost of the Final Rule	Average Cost per Entity	Ratio of Average Cost to Revenues	Ratio of Average Cost to Profits
4236	Electrical and Electronic Goods Merchant Wholesalers	100	\$116,205,481	19,024	\$6,108,282	2.13%	\$130,040	\$791,810	\$41.62	0.001%	0.032%
4237	Hardware, and Plumbing and Heating Equipment and Supplies Merchant Wholesalers	100	\$47,399,143	10,751	\$4,408,710	3.18%	\$140,041	\$583,565	\$54.28	0.001%	0.039%
4238	Machinery, Equipment, and Supplies Merchant Wholesalers	100	\$197,666,925	41,809	\$4,727,813	3.49%	\$164,938	\$2,439,487	\$58.35	0.001%	0.035%
4239	Miscellaneous Durable Goods Merchant Wholesalers	100	\$159,740,319	30,313	\$5,269,697	2.74%	\$144,375	\$835,162	\$27.55	0.001%	0.019%
4241	Paper and Paper Product Merchant Wholesalers	100	\$36,553,039	8,752	\$4,176,774	2.02%	\$84,509	\$186,075	\$21.26	0.001%	0.025%
4242	Drugs and Druggists' Sundries Merchant Wholesalers	100	\$34,187,543	5,838	\$5,856,288	3.42%	\$200,496	\$115,976	\$19.87	0.000%	0.010%
4243	Apparel, Piece Goods, and Notions Merchant Wholesalers	100	\$81,945,442	14,426	\$5,680,399	4.68%	\$266,013	\$252,181	\$17.48	0.000%	0.007%
4244	Grocery and Related Product Wholesalers	100	\$204,506,779	26,532	\$7,708,002	2.81%	\$216,545	\$681,757	\$25.70	0.000%	0.012%

Table V-32
Average Cost Impacts on Small Business Entities Affected by OSHA's Final Revision to Subparts D and I
(per Entity, by 4-Digit NAICS Code)

NAICS	Industry	SBA Employment Size Criterion [a]	Estimated Receipts, 2007 (\$1,000)[b]	Entities [c]	Average Receipts per Entity	Profit Rate [d]	Estimated Profits per Entity	Estimated Cost of the Final Rule	Average Cost per Entity	Ratio of Average Cost to Revenues	Ratio of Average Cost to Profits
4245	Farm Product Raw Material Merchant Wholesalers	100	\$55,679,278	3,844	\$14,484,724	2.03%	\$293,520	\$105,896	\$27.55	0.000%	0.009%
4246	Chemical and Allied Products Merchant Wholesalers	100	\$50,173,511	7,934	\$6,324,060	3.26%	\$206,061	\$287,804	\$36.28	0.001%	0.018%
4247	Petroleum and Petroleum Products Merchant Wholesalers	100	\$204,677,503	4,478	\$45,709,900	1.90%	\$867,895	\$294,762	\$65.83	0.000%	0.008%
4248	Beer, Wine, and Distilled Alcoholic Beverage Merchant Wholesalers	100	\$32,849,344	2,999	\$10,952,519	3.77%	\$412,883	\$87,205	\$29.08	0.000%	0.007%
4249	Miscellaneous Nondurable Goods Merchant Wholesalers	100	\$91,126,788	24,660	\$3,695,365	2.93%	\$108,386	\$515,371	\$20.90	0.001%	0.019%
4251	Wholesale Electronic Markets and Agents and Brokers	100	\$387,328,579	53,561	\$7,231,541	7.55% *	\$546,167	\$1,589,585	\$29.68	0.000%	0.005%
4411	Automobile Dealers	20	\$443,192,194	44,316	\$10,000,839	0.98%	\$97,724	\$1,356,335	\$30.61	0.000%	0.031%
4412	Other Motor Vehicle Dealers	100	\$57,025,140	15,120	\$3,771,504	2.52% **	\$95,100	\$564,057	\$37.31	0.001%	0.039%
4413	Automotive Parts, Accessories, and Tire Stores	100	\$42,888,527	32,330	\$1,326,586	1.24% *	\$16,475	\$939,806	\$29.07	0.002%	0.176%
4421	Furniture Stores	100	\$35,470,338	19,802	\$1,791,250	3.06% *	\$54,735	\$410,300	\$20.72	0.001%	0.038%
4422	Home Furnishings Stores	100	\$30,067,318	26,202	\$1,147,520	3.06% *	\$35,064	\$648,103	\$24.73	0.002%	0.071%

Table V-32
Average Cost Impacts on Small Business Entities Affected by OSHA's Final Revision to Subparts D and I
(per Entity, by 4-Digit NAICS Code)

NAICS	Industry	SBA Employment Size Criterion [a]	Estimated Receipts, 2007 (\$1,000)[b]	Entities [c]	Average Receipts per Entity	Profit Rate [d]	Estimated Profits per Entity	Estimated Cost of the Final Rule	Average Cost per Entity	Ratio of Average Cost to Revenues	Ratio of Average Cost to Profits
4431	Electronics and Appliance Stores	20	\$38,835,791	30,335	\$1,280,230	3.29% *	\$42,096	\$696,841	\$22.97	0.002%	0.055%
4441	Building Material and Supplies Dealers	100	\$116,471,660	45,176	\$2,578,176	7.66% *	\$197,571	\$1,559,771	\$34.53	0.001%	0.017%
4442	Lawn and Garden Equipment and Supplies Stores	100	\$33,831,920	16,635	\$2,033,779	1.81% **	\$36,730	\$481,335	\$28.94	0.001%	0.079%
4451	Grocery Stores	100	\$110,655,741	65,430	\$1,691,208	2.00% *	\$33,865	\$790,579	\$12.08	0.001%	0.036%
4452	Specialty Food Stores	100	\$17,713,135	23,426	\$756,131	2.00% *	\$15,141	\$337,519	\$14.41	0.002%	0.095%
4453	Beer, Wine, and Liquor Stores	100	\$30,450,794	26,833	\$1,134,826	2.07% *	\$23,478	\$320,512	\$11.94	0.001%	0.051%
4461	Health and Personal Care Stores	100	\$80,787,975	43,539	\$1,855,531	3.06% *	\$56,706	\$614,009	\$14.10	0.001%	0.025%
4471	Gasoline Stations	100	\$235,407,146	65,359	\$3,601,756	0.86% *	\$30,907	\$1,791,895	\$27.42	0.001%	0.089%
4481	Clothing Stores	100	\$33,291,641	40,794	\$816,092	5.15% *	\$42,037	\$611,963	\$15.00	0.002%	0.036%
4482	Shoe Stores	100	\$6,858,608	6,641	\$1,032,767	5.15% *	\$53,198	\$68,997	\$10.39	0.001%	0.020%
4483	Jewelry, Luggage, and Leather Goods Stores	100	\$18,847,729	19,038	\$990,006	5.15% *	\$50,995	\$354,928	\$18.64	0.002%	0.037%
4511	Sporting Goods, Hobby, and Musical Instrument Stores	100	\$26,098,603	31,702	\$823,248	2.62% *	\$21,558	\$710,405	\$22.41	0.003%	0.104%
4512	Book, Periodical, and Music Stores	100	\$6,664,077	9,053	\$736,118	2.62% *	\$19,276	\$125,471	\$13.86	0.002%	0.072%
4521	Department Stores	100	\$634,076	394	\$1,609,330	4.15% *	\$66,771	\$7,006	\$17.78	0.001%	0.027%
4529	Other General Merchandise Stores	100	\$8,449,800	10,002	\$844,811	4.15% *	\$35,051	\$189,005	\$18.90	0.002%	0.054%
4531	Florists	100	\$6,272,242	18,941	\$331,146	3.23% *	\$10,692	\$209,493	\$11.06	0.003%	0.103%

Table V-32 Average Cost Impacts on Small Business Entities Affected by OSHA's Final Revision to Subparts D and I (per Entity, by 4-Digit NAICS Code)												
NAICS	Industry	SBA Employment Size Criterion [a]	Estimated Receipts, 2007 (\$1,000)[b]	Entities [c]	Average Receipts per Entity	Profit Rate [d]	Estimated Profits per Entity	Estimated Cost of the Final Rule	Average Cost per Entity	Ratio of Average Cost to Revenues	Ratio of Average Cost to Profits	
4532	Office Supplies, Stationery, and Gift Stores	500	\$17,012,759	28,693	\$592,924	3.23% *	\$19,145	\$544,680	\$18.98	0.003%	0.099%	
4533	Used Merchandise Stores	100	\$7,323,864	13,005	\$563,158	3.23% *	\$18,184	\$198,837	\$15.29	0.003%	0.084%	
4539	Other Miscellaneous Store Retailers	100	\$39,861,928	36,844	\$1,081,911	3.23% *	\$34,934	\$909,311	\$24.68	0.002%	0.071%	
4541	Electronic Shopping and Mail-Order Houses	100	\$44,357,730	14,940	\$2,969,058	3.75% *	\$111,413	\$237,352	\$15.89	0.001%	0.014%	
4542	Vending Machine Operators	100	\$5,134,462	4,518	\$1,136,446	3.75% *	\$42,645	\$181,494	\$40.17	0.004%	0.094%	
4543	Direct Selling Establishments	20	\$22,403,680	19,679	\$1,138,456	3.75% *	\$42,720	\$488,472	\$24.82	0.002%	0.058%	
4811	Scheduled Air Transportation	1,500	\$9,851,112	538	\$18,310,617	2.57% *	\$470,274	\$864,379	\$1,606.65	0.009%	0.342%	
4812	Nonscheduled Air Transportation	1,500	\$8,890,730	2,304	\$3,858,824	2.57% *	\$99,107	\$264,726	\$114.90	0.003%	0.116%	
4831	Deep Sea, Coastal, and Great Lakes Water Transportation	20	\$8,477,469	838	\$10,116,311	6.37% *	\$644,012	\$170,817	\$203.84	0.002%	0.032%	
4832	Inland Water Transportation	500	\$2,084,918	580	\$3,594,686	6.21% *	\$223,194	\$183,302	\$316.04	0.009%	0.142%	
4841	General Freight Trucking	500	\$74,888,330	58,091	\$1,289,155	6.21% *	\$80,044	\$1,367,747	\$23.54	0.002%	0.029%	
4842	Specialized Freight Trucking	500	\$55,163,013	47,947	\$1,150,500	2.51% *	\$28,927	\$1,143,121	\$23.84	0.002%	0.082%	
4851	Urban Transit Systems	100	\$824,244	566	\$1,456,261	2.51% *	\$36,615	\$51,925	\$91.74	0.006%	0.251%	

Table V-32
Average Cost Impacts on Small Business Entities Affected by OSHA's Final Revision to Subparts D and I
(per Entity, by 4-Digit NAICS Code)

NAICS	Industry	SBA Employment Size Criterion [a]	Estimated Receipts, 2007 (\$1,000)[b]	Entities [c]	Average Receipts per Entity	Profit Rate [d]	Estimated Profits per Entity	Estimated Cost of the Final Rule	Average Cost per Entity	Ratio of Average Cost to Revenues	Ratio of Average Cost to Profits
4852	Interurban and Rural Bus Transportation	100	\$554,776	224	\$2,476,679	2.13% *	\$52,741	\$18,923	\$84.48	0.003%	0.160%
4853	Taxi and Limousine Service	500	\$4,978,224	7,290	\$682,884	2.13% *	\$14,542	\$162,816	\$22.33	0.003%	0.154%
4854	School and Employee Bus Transportation	100	\$3,320,869	3,045	\$1,090,597	2.13% *	\$23,224	\$137,140	\$45.04	0.004%	0.194%
4855	Charter Bus Industry	500	\$1,781,963	1,118	\$1,593,885	2.13% *	\$33,942	\$52,919	\$47.33	0.003%	0.139%
4859	Other Transit and Ground Passenger Transportation	500	\$3,828,458	3,196	\$1,197,890	2.13% *	\$25,509	\$126,394	\$39.55	0.003%	0.155%
4861	Pipeline Transportation of Crude Oil	1,500	\$860,780	42	\$20,494,772	13.23% *	\$2,711,340	\$23,669	\$563.54	0.003%	0.021%
4862	Pipeline Transportation of Natural Gas	500	\$2,298,538	84	\$27,363,548	13.23% *	\$3,620,040	\$12,249	\$145.82	0.001%	0.004%
4869	Other Pipeline Transportation	500	\$1,137,749	56	\$20,316,946	13.23% *	\$2,687,815	\$5,561	\$99.30	0.000%	0.004%
4871	Scenic and Sightseeing Transportation, Land	500	\$559,211	635	\$880,647	13.23% *	\$116,505	\$15,916	\$25.06	0.003%	0.022%
4872	Scenic and Sightseeing Transportation, Water	500	\$1,127,304	1,821	\$619,058	4.42% *	\$27,384	\$61,569	\$33.81	0.005%	0.123%
4879	Scenic and Sightseeing Transportation, Other	100	\$392,857	188	\$2,089,665	4.42% *	\$92,436	\$9,690	\$51.54	0.002%	0.056%
4881	Support Activities for Air Transportation	100	\$7,164,833	3,947	\$1,815,260	4.42% **	\$80,297	\$412,902	\$104.61	0.006%	0.130%

Table V-32
Average Cost Impacts on Small Business Entities Affected by OSHA's Final Revision to Subparts D and I
(per Entity, by 4-Digit NAICS Code)

NAICS	Industry	SBA Employment Size Criterion [a]	Estimated Receipts, 2007 (\$1,000)[b]	Entities [c]	Average Receipts per Entity	Profit Rate [d]	Estimated Profits per Entity	Estimated Cost of the Final Rule	Average Cost per Entity	Ratio of Average Cost to Revenues	Ratio of Average Cost to Profits
4882	Support Activities for Rail Transportation	100	\$1,272,169	480	\$2,650,352	3.19% **	\$84,575	\$120,434	\$250.90	0.009%	0.297%
4883	Support Activities for Water Transportation	100	\$5,416,618	1,765	\$3,068,905	3.19% **	\$97,931	\$130,434	\$73.90	0.002%	0.075%
4884	Support Activities for Road Transportation	100	\$5,813,392	9,249	\$628,543	3.19% **	\$20,057	\$312,411	\$33.78	0.005%	0.168%
4885	Freight Transportation Arrangement	100	\$27,524,202	12,667	\$2,172,906	3.19% **	\$69,339	\$272,517	\$21.51	0.001%	0.031%
4889	Other Support Activities for Transportation	100	\$1,868,396	1,551	\$1,204,640	3.19% **	\$38,441	\$25,461	\$16.42	0.001%	0.043%
4921	Couriers	1,500	\$4,178,767	3,747	\$1,115,230	3.19% **	\$35,588	\$353,871	\$94.44	0.008%	0.265%
4922	Local Messengers and Local Delivery	500	\$4,150,565	4,330	\$958,560	3.19% **	\$30,588	\$77,208	\$17.83	0.002%	0.058%
4931	Warehousing and Storage	100	\$39,951,180	7,410	\$5,391,522	4.59% *	\$247,368	\$179,796	\$24.26	0.000%	0.010%
5111	Newspaper, Periodical, Book, and Directory Publishers	500	\$43,902,360	16,643	\$2,637,887	11.69% *	\$308,246	\$398,651	\$23.95	0.001%	0.008%
5112	Software Publishers	500	\$23,859,487	5,601	\$4,259,862	16.22% *	\$691,000	\$226,680	\$40.47	0.001%	0.006%
5121	Motion Picture and Video Industries	500	\$25,078,127	17,429	\$1,438,874	6.24% **	\$89,721	\$394,399	\$22.63	0.002%	0.025%
5122	Sound Recording Industries	100	\$1,654,218	3,425	\$482,983	7.26% **	\$35,081	\$207,546	\$60.60	0.013%	0.173%
5151	Radio and Television Broadcasting	20	\$10,268,764	4,606	\$2,229,432	6.79% *	\$151,272	\$174,604	\$37.91	0.002%	0.025%
5152	Cable and Other Subscription Programming	500	\$3,601,413	341	\$10,561,328	6.79% *	\$716,609	\$160,191	\$469.77	0.004%	0.066%

Table V-32
Average Cost Impacts on Small Business Entities Affected by OSHA's Final Revision to Subparts D and I
(per Entity, by 4-Digit NAICS Code)

NAICS	Industry	SBA Employment Size Criterion [a]	Estimated Receipts, 2007 (\$1,000)[b]	Entities [c]	Average Receipts per Entity	Profit Rate [d]	Estimated Profits per Entity	Estimated Cost of the Final Rule	Average Cost per Entity	Ratio of Average Cost to Revenues	Ratio of Average Cost to Profits
5161	Internet Publishing and Broadcasting	500	\$5,485,257	2,333	\$2,351,160	7.06% *	\$165,988	\$177,116	\$75.92	0.003%	0.046%
5171	Wired Telecommunications Carriers	1,500	\$16,702,548	2,004	\$8,334,605	6.40% *	\$533,712	\$5,879,440	\$2,933.85	0.035%	0.550%
5172	Wireless Telecommunications Carriers (except Satellite)	1,500	\$8,683,535	1,711	\$5,075,123	6.40% *	\$324,989	\$413,650	\$241.76	0.005%	0.074%
5173	Telecommunications Resellers	1,500	\$13,331,322	3,107	\$4,290,738	6.40% *	\$274,760	\$753,777	\$242.61	0.006%	0.088%
5174	Satellite Telecommunications	1,000	\$3,001,157	530	\$5,662,560	6.40% *	\$362,606	\$288,672	\$544.66	0.010%	0.150%
5175	Cable and Other Program Distribution	1,000	\$2,796,836	947	\$2,953,364	6.40% *	\$189,121	\$122,259	\$129.10	0.004%	0.068%
5179	Other Telecommunications	1,000	\$2,226,640	1,260	\$1,767,175	6.40% *	\$113,162	\$192,504	\$152.78	0.009%	0.135%
5181	Internet Service Providers and Web Search Portals	1,000	\$7,943,835	3,747	\$2,120,052	7.21% *	\$152,828	\$200,636	\$53.55	0.003%	0.035%
5182	Data Processing, Hosting, and Related Services	1,000	\$22,685,667	7,112	\$3,189,773	7.21% *	\$229,941	\$184,911	\$26.00	0.001%	0.011%
5191	Other Information Services	1,000	\$3,073,430	3,349	\$917,716	8.78% *	\$80,572	\$189,407	\$56.56	0.006%	0.070%
5211	Monetary Authorities - Central Bank	1,000	\$302,753	53	\$5,712,321	5.83% *	\$333,247	\$5,985	\$112.92	0.002%	0.034%
5221	Depository Credit Intermediation	20	\$182,794,953	15,010	\$12,178,211	9.42% *	\$1,146,679	\$185,843	\$12.38	0.000%	0.001%

NAICS	Industry	SBA Employment Size Criterion [a]	Estimated Receipts, 2007 (\$1,000)[b]	Entities [c]	Average Receipts per Entity	Profit Rate [d]	Estimated Profits per Entity	Estimated Cost of the Final Rule	Average Cost per Entity	Ratio of Average Cost to Revenues	Ratio of Average Cost to Profits
5222	Nondepository Credit Intermediation	100	\$109,214,617	23,197	\$4,708,135	7.53% *	\$354,747	\$236,702	\$10.20	0.000%	0.003%
5223	Activities Related to Credit Intermediation	20	\$25,947,702	27,577	\$940,918	10.33% **	\$97,202	\$301,270	\$10.92	0.001%	0.011%
5231	Securities and Commodity Contracts Intermediation and Brokerage	100	\$43,913,430	12,731	\$3,449,331	5.99% *	\$206,477	\$146,774	\$11.53	0.000%	0.006%
5232	Securities and Commodity Exchanges	100	\$829,893	117	\$7,093,103	5.99% *	\$424,592	\$3,100	\$26.50	0.000%	0.006%
5239	Other Financial Investment Activities	100	\$117,296,054	43,788	\$2,678,726	31.09% *	\$832,689	\$459,208	\$10.49	0.000%	0.001%
5241	Insurance Carriers	100	\$89,744,365	6,849	\$13,103,280	4.56% *	\$597,869	\$86,030	\$12.56	0.000%	0.002%
5242	Agencies, Brokerages, and Other Insurance Related Activities	20	\$96,095,730	130,229	\$737,898	4.56% *	\$33,668	\$1,153,096	\$8.85	0.001%	0.026%
5259	Other Investment Pools and Funds	20	\$4,149,107	1,965	\$2,111,505	65.69% *	\$1,386,955	\$28,360	\$14.43	0.00%	0.001%
5311	Lessors of Real Estate	100	\$99,265,980	95,427	\$1,040,229	13.62% *	\$141,664	\$1,681,882	\$17.62	0.002%	0.012%
5312	Offices of Real Estate Agents and Brokers	100	\$70,375,455	100,495	\$700,288	8.22% *	\$57,554	\$1,123,102	\$11.18	0.002%	0.019%
5313	Activities Related to Real Estate	100	\$55,573,813	73,945	\$751,556	13.62% *	\$102,351	\$1,207,599	\$16.33	0.002%	0.016%
5321	Automotive Equipment Rental and Leasing	500	\$8,909,501	4,629	\$1,924,714	2.43% **	\$46,838	\$75,614	\$16.33	0.001%	0.035%

Table V-32
Average Cost Impacts on Small Business Entities Affected by OSHA's Final Revision to Subparts D and I
(per Entity, by 4-Digit NAICS Code)

NAICS	Industry	SBA Employment Size Criterion [a]	Estimated Receipts, 2007 (\$1,000)[b]	Entities [c]	Average Receipts per Entity	Profit Rate [d]	Estimated Profits per Entity	Estimated Cost of the Final Rule	Average Cost per Entity	Ratio of Average Cost to Revenues	Ratio of Average Cost to Profits
5322	Consumer Goods Rental	100	\$8,145,582	12,034	\$676,881	3.69% *	\$24,970	\$145,586	\$12.10	0.002%	0.048%
5323	General Rental Centers	100	\$3,512,015	3,167	\$1,108,941	3.69% *	\$40,909	\$54,139	\$17.09	0.002%	0.042%
5324	Commercial and Industrial Machinery and Equipment Rental and Leasing	100	\$20,012,355	8,368	\$2,391,534	5.35% **	\$127,991	\$157,061	\$18.77	0.001%	0.015%
5331	Lessors of Nonfinancial Intangible Assets (except Copyrighted Works)	100	\$8,060,046	2,335	\$3,451,840	29.11% *	\$1,004,711	\$21,210	\$9.08	0.000%	0.001%
5411	Legal Services	100	\$168,755,635	180,282	\$936,065	8.86% **	\$82,974	\$2,136,675	\$11.85	0.001%	0.014%
5412	Accounting, Tax Preparation, Bookkeeping, and Payroll Services	500	\$59,259,539	107,843	\$549,498	7.81% **	\$42,920	\$1,449,633	\$13.44	0.002%	0.031%
5413	Architectural, Engineering, and Related Services	100	\$144,115,123	98,918	\$1,456,915	4.79% **	\$69,714	\$2,125,094	\$21.48	0.001%	0.031%
5414	Specialized Design Services	100	\$23,155,463	34,304	\$675,008	5.48% **	\$36,974	\$510,832	\$14.89	0.002%	0.040%
5415	Computer Systems Design and Related Services	500	\$130,320,040	102,538	\$1,270,944	5.02% **	\$63,761	\$1,955,349	\$19.07	0.002%	0.030%
5416	Management, Scientific, and Technical Consulting Services	100	\$119,314,020	141,356	\$844,068	7.49% **	\$63,215	\$2,230,048	\$15.78	0.002%	0.025%

Table V-32
Average Cost Impacts on Small Business Entities Affected by OSHA's Final Revision to Subparts D and I
(per Entity, by 4-Digit NAICS Code)

NAICS	Industry	SBA Employment Size Criterion [a]	Estimated Receipts, 2007 (\$1,000)[b]	Entities [c]	Average Receipts per Entity	Profit Rate [d]	Estimated Profits per Entity	Estimated Cost of the Final Rule	Average Cost per Entity	Ratio of Average Cost to Revenues	Ratio of Average Cost to Profits
5417	Scientific Research and Development Services	100	\$47,783,246	13,440	\$3,555,301	2.14% **	\$76,215	\$376,368	\$28.00	0.001%	0.037%
5418	Advertising and Related Services	500	\$54,654,241	36,283	\$1,506,332	5.13% **	\$77,332	\$11,247,212	\$309.99	0.021%	0.401%
5419	Other Professional, Scientific, and Technical Services	500	\$50,054,663	64,099	\$780,896	6.72% **	\$52,488	\$839,864	\$13.10	0.002%	0.025%
5511	Management of Companies and Enterprises	100	\$75,486,690	20,794	\$3,630,215	6.72% **	\$244,004	\$448,375	\$21.56	0.001%	0.009%
5611	Office Administrative Services	100	\$42,852,939	25,338	\$1,691,252	12.73% *	\$215,323	\$481,328	\$19.00	0.001%	0.009%
5612	Facilities Support Services	500	\$4,603,262	1,500	\$3,068,841	4.21% *	\$129,072	\$76,594	\$51.06	0.002%	0.040%
5613	Employment Services	100	\$44,575,894	23,151	\$1,925,441	4.21% **	\$80,982	\$533,594	\$23.05	0.001%	0.028%
5614	Business Support Services	100	\$28,391,249	29,302	\$968,918	2.66% *	\$25,813	\$367,799	\$12.55	0.001%	0.049%
5615	Travel Arrangement and Reservation Services	100	\$16,631,010	16,703	\$995,690	4.21% **	\$41,877	\$172,249	\$10.31	0.001%	0.025%
5616	Investigation and Security Services	100	\$17,080,251	19,479	\$876,855	3.30% *	\$28,960	\$384,732	\$19.75	0.002%	0.068%
5617	Services to Buildings and Dwellings	100	\$82,911,097	172,700	\$480,087	4.21% *	\$20,192	\$89,103,422	\$515.94	0.107%	2.555%
5619	Other Support Services	100	\$26,157,479	18,223	\$1,435,410	4.21% *	\$60,372	\$311,286	\$17.08	0.001%	0.028%
5621	Waste Collection	500	\$14,389,120	7,666	\$1,877,005	5.44% *	\$102,117	\$186,579	\$24.34	0.001%	0.024%

Table V-32
Average Cost Impacts on Small Business Entities Affected by OSHA's Final Revision to Subparts D and I
(per Entity, by 4-Digit NAICS Code)

NAICS	Industry	SBA Employment Size Criterion [a]	Estimated Receipts, 2007 (\$1,000)[b]	Entities [c]	Average Receipts per Entity	Profit Rate [d]	Estimated Profits per Entity	Estimated Cost of the Final Rule	Average Cost per Entity	Ratio of Average Cost to Revenues	Ratio of Average Cost to Profits
5622	Waste Treatment and Disposal	100	\$5,060,315	1,534	\$3,298,771	4.79% *	\$157,930	\$75,692	\$49.34	0.001%	0.031%
5629	Remediation and Other Waste Management Services	100	\$13,326,878	7,883	\$1,690,585	4.79% *	\$80,937	\$232,298	\$29.47	0.002%	0.036%
6111	Elementary and Secondary Schools	100	\$55,736,852	16,490	\$3,380,040	7.60% **	\$257,015	\$271,750	\$16.48	0.000%	0.006%
6112	Junior Colleges	500	\$2,336,568	288	\$8,113,083	7.60% **	\$616,911	\$19,858	\$68.95	0.001%	0.011%
6113	Colleges, Universities, and Professional Schools	100	\$13,007,384	1,718	\$7,571,236	7.60% **	\$575,709	\$25,819	\$15.03	0.000%	0.003%
6114	Business Schools and Computer and Management Training	100	\$7,444,657	6,832	\$1,089,675	7.60% **	\$82,858	\$85,144	\$12.46	0.001%	0.015%
6115	Technical and Trade Schools	500	\$7,026,736	6,442	\$1,090,769	7.60% **	\$82,941	\$105,258	\$16.34	0.001%	0.020%
6116	Other Schools and Instruction	100	\$13,872,429	35,635	\$389,292	7.60% **	\$29,601	\$393,156	\$11.03	0.003%	0.037%
6117	Educational Support Services	100	\$7,107,117	5,917	\$1,201,135	7.60% **	\$91,333	\$77,080	\$13.03	0.001%	0.014%
6211	Offices of Physicians	100	\$265,079,147	189,252	\$1,400,668	4.56% *	\$63,816	\$1,807,322	\$9.55	0.001%	0.015%
6212	Offices of Dentists	100	\$90,979,014	120,488	\$755,088	7.66% *	\$57,824	\$1,157,098	\$9.60	0.001%	0.017%
6213	Offices of Other Health Practitioners	100	\$45,983,749	112,089	\$410,243	7.78% *	\$31,937	\$965,995	\$8.62	0.002%	0.027%
6214	Outpatient Care Centers	500	\$33,986,651	12,233	\$2,778,276	5.34% *	\$148,406	\$163,526	\$13.37	0.000%	0.009%

Table V-32
Average Cost Impacts on Small Business Entities Affected by OSHA's Final Revision to Subparts D and I
(per Entity, by 4-Digit NAICS Code)

NAICS	Industry	SBA Employment Size Criterion [a]	Estimated Receipts, 2007 (\$1,000)[b]	Entities [c]	Average Receipts per Entity	Profit Rate [d]	Estimated Profits per Entity	Estimated Cost of the Final Rule	Average Cost per Entity	Ratio of Average Cost to Revenues	Ratio of Average Cost to Profits
6215	Medical and Diagnostic Laboratories	500	\$20,124,407	7,464	\$2,696,196	5.51% *	\$148,667	\$85,946	\$11.51	0.000%	0.008%
6216	Home Health Care Services	20	\$24,316,866	15,764	\$1,542,557	5.51% *	\$85,056	\$171,902	\$10.90	0.001%	0.013%
6219	Other Ambulatory Health Care Services	100	\$12,200,189	5,449	\$2,238,978	5.51% *	\$123,456	\$66,395	\$12.18	0.001%	0.010%
6221	General Medical and Surgical Hospitals	20	\$29,788,752	1,674	\$17,794,953	5.24% **	\$932,315	\$21,324	\$12.74	0.000%	0.001%
6222	Psychiatric and Substance Abuse Hospitals	20	\$4,235,063	326	\$12,990,991	5.24% **	\$680,625	\$4,347	\$13.33	0.000%	0.002%
6223	Specialty (except Psychiatric and Substance Abuse) Hospitals	20	\$2,962,810	401	\$7,388,554	5.24% **	\$387,102	\$6,753	\$16.84	0.000%	0.004%
6231	Nursing Care Facilities	500	\$41,876,375	7,832	\$5,346,830	5.24% **	\$280,132	\$100,545	\$12.84	0.000%	0.005%
6232	Residential Mental Retardation, Mental Health and Substance Abuse Facilities	100	\$14,585,730	8,036	\$1,815,049	5.24% **	\$95,094	\$68,213	\$8.49	0.000%	0.009%
6233	Community Care Facilities for the Elderly	100	\$19,733,146	14,491	\$1,361,752	5.24% **	\$71,345	\$125,759	\$8.68	0.001%	0.012%
6239	Other Residential Care Facilities	100	\$6,041,833	3,523	\$1,714,968	5.24% **	\$89,851	\$32,833	\$9.32	0.001%	0.010%
6241	Individual and Family Services	100	\$50,250,251	40,591	\$1,237,965	5.24% **	\$64,860	\$382,358	\$9.42	0.001%	0.015%

Table V-32
Average Cost Impacts on Small Business Entities Affected by OSHA's Final Revision to Subparts D and I
(per Entity, by 4-Digit NAICS Code)

NAICS	Industry	SBA Employment Size Criterion [a]	Estimated Receipts, 2007 (\$1,000)[b]	Entities [c]	Average Receipts per Entity	Profit Rate [d]	Estimated Profits per Entity	Estimated Cost of the Final Rule	Average Cost per Entity	Ratio of Average Cost to Revenues	Ratio of Average Cost to Profits
6242	Community Food and Housing, and Emergency and Other Relief Services	100	\$19,349,321	9,325	\$2,074,994	5.24% **	\$108,713	\$86,660	\$9.29	0.000%	0.009%
6243	Vocational Rehabilitation Services	100	\$8,265,697	4,249	\$1,945,328	5.24% **	\$101,920	\$33,711	\$7.93	0.000%	0.008%
6244	Child Day Care Services	100	\$23,735,204	59,716	\$397,468	5.24% **	\$20,824	\$443,692	\$7.43	0.002%	0.036%
7111	Performing Arts Companies	500	\$11,640,787	9,255	\$1,257,784	8.99% *	\$113,035	\$897,260	\$96.95	0.008%	0.086%
7112	Spectator Sports	100	\$17,228,395	4,194	\$4,107,867	8.99% *	\$369,167	\$90,496	\$21.58	0.001%	0.006%
7113	Promoters of Performing Arts, Sports, and Similar Events	20	\$8,206,151	5,982	\$1,371,807	8.99% *	\$123,282	\$185,112	\$30.94	0.002%	0.025%
7114	Agents and Managers for Artists, Athletes, Entertainers, and Other Public Figures	500	\$4,029,130	3,620	\$1,113,019	8.99% *	\$100,025	\$45,715	\$12.63	0.001%	0.013%
7115	Independent Artists, Writers, and Performers	500	\$12,619,303	20,044	\$629,580	8.99% *	\$56,579	\$214,084	\$10.68	0.002%	0.019%
7121	Museums, Historical Sites, and Similar Institutions	100	\$9,970,695	6,778	\$1,471,038	6.69% **	\$98,355	\$77,873	\$11.49	0.001%	0.012%
7131	Amusement Parks and Arcades	100	\$2,438,790	2,555	\$954,517	4.94% *	\$47,189	\$40,212	\$15.74	0.002%	0.033%
7132	Gambling Industries	500	\$8,341,034	1,988	\$4,195,691	4.94% *	\$207,423	\$24,338	\$12.24	0.000%	0.006%

Table V-32
Average Cost Impacts on Small Business Entities Affected by OSHA's Final Revision to Subparts D and I
(per Entity, by 4-Digit NAICS Code)

NAICS	Industry	SBA Employment Size Criterion [a]	Estimated Receipts, 2007 (\$1,000)[b]	Entities [c]	Average Receipts per Entity	Profit Rate [d]	Estimated Profits per Entity	Estimated Cost of the Final Rule	Average Cost per Entity	Ratio of Average Cost to Revenues	Ratio of Average Cost to Profits
7139	Other Amusement and Recreation Industries	100	\$45,100,926	61,465	\$733,766	4.94% *	\$36,275	\$729,434	\$11.87	0.002%	0.033%
7211	Traveler Accommodation	100	\$53,634,734	43,818	\$1,224,034	5.14% *	\$62,922	\$729,551	\$16.65	0.001%	0.026%
7212	RV (Recreational Vehicle) Parks and Recreational Camps	100	\$3,904,302	6,809	\$573,403	5.14% *	\$29,476	\$90,069	\$13.23	0.002%	0.045%
7213	Rooming and Boarding Houses	100	\$827,450	2,117	\$390,860	5.14% *	\$20,092	\$25,738	\$12.16	0.003%	0.061%
7221	Full-Service Restaurants	500	\$127,043,572	188,281	\$674,755	4.61% *	\$31,079	\$1,742,715	\$9.26	0.001%	0.030%
7222	Limited-Service Eating Places	100	\$114,142,231	173,832	\$656,624	4.61% *	\$30,244	\$1,504,625	\$8.66	0.001%	0.029%
7223	Special Food Services	100	\$10,765,010	15,095	\$713,151	4.61% *	\$32,847	\$228,401	\$15.13	0.002%	0.046%
7224	Drinking Places (Alcoholic Beverages)	100	\$17,750,257	46,253	\$383,764	4.61% *	\$17,676	\$437,994	\$9.47	0.002%	0.054%
8111	Automotive Repair and Maintenance	100	\$82,369,042	152,030	\$541,795	3.25% *	\$17,616	\$3,851,769	\$25.34	0.005%	0.144%
8112	Electronic and Precision Equipment Repair and Maintenance	20	\$10,041,369	11,232	\$893,997	4.90% *	\$43,826	\$207,343	\$18.46	0.002%	0.042%

Table V-32
Average Cost Impacts on Small Business Entities Affected by OSHA's Final Revision to Subparts D and I
(per Entity, by 4-Digit NAICS Code)

NAICS	Industry	SBA Employment Size Criterion [a]	Estimated Receipts, 2007 (\$1,000)[b]	Entities [c]	Average Receipts per Entity	Profit Rate [d]	Estimated Profits per Entity	Estimated Cost of the Final Rule	Average Cost per Entity	Ratio of Average Cost to Revenues	Ratio of Average Cost to Profits
8113	Commercial and Industrial Machinery and Equipment (except Automotive and Electronic) Repair and Maintenance	100	\$22,502,761	21,850	\$1,029,875	4.90% *	\$50,487	\$553,520	\$25.33	0.002%	0.050%
8114	Personal and Household Goods Repair and Maintenance	500	\$7,534,240	21,868	\$344,533	4.90% *	\$16,890	\$336,963	\$15.41	0.004%	0.091%
8121	Personal Care Services	100	\$22,490,631	96,852	\$232,216	5.12% *	\$11,880	\$722,467	\$7.46	0.003%	0.063%
8122	Death Care Services	20	\$12,218,211	15,760	\$775,267	5.12% *	\$39,663	\$155,848	\$9.89	0.001%	0.025%
8123	Dry-cleaning and Laundry Services	20	\$13,570,864	33,896	\$400,368	5.12% *	\$20,483	\$337,527	\$9.96	0.002%	0.049%
8129	Other Personal Services	20	\$11,794,640	25,713	\$458,703	5.12% *	\$23,468	\$298,050	\$11.59	0.003%	0.049%
8131	Religious Organizations	20	\$112,912,515	178,395	\$632,935	2.05% *	\$12,968	\$1,614,463	\$9.05	0.001%	0.070%
8132	Grantmaking and Giving Services	20	\$84,918,809	14,131	\$6,009,398	2.05% *	\$123,126	\$145,943	\$10.33	0.000%	0.008%
8133	Social Advocacy Organizations	20	\$15,775,057	13,019	\$1,211,695	2.05% *	\$24,826	\$129,562	\$9.95	0.001%	0.040%
8134	Civic and Social Organizations	20	\$16,708,923	26,900	\$621,150	2.05% *	\$12,727	\$295,983	\$11.00	0.002%	0.086%

Table V-32
Average Cost Impacts on Small Business Entities Affected by OSHA's Final Revision to Subparts D and I
(per Entity, by 4-Digit NAICS Code)

NAICS	Industry	SBA Employment Size Criterion [a]	Estimated Receipts, 2007 (\$1,000)[b]	Entities [c]	Average Receipts per Entity	Profit Rate [d]	Estimated Profits per Entity	Estimated Cost of the Final Rule	Average Cost per Entity	Ratio of Average Cost to Revenues	Ratio of Average Cost to Profits
8139	Business, Professional, Labor, Political, and Similar Organizations	20	\$68,099,014	60,844	\$1,119,240	2.05% *	\$22,932	\$832,384	\$13.68	0.001%	0.060%

[a] SBA criteria specified in dollar terms converted to size-class definition based on average revenues for different size establishments. Most restrictive criterion for 6-digit NAICS applied to the 4-digit NAICS level.

[b] Estimated based on 2007 receipts and payroll data from U.S. Census Bureau, Statistics of U.S. Businesses, 2007, and payroll data from U.S. Census Bureau, Statistics of U.S. Businesses, 2007.

[c] U.S. Census Bureau, Statistics of U.S. Businesses, 2007.

[d] Estimated from average of the yearly ratios of net income to total receipts as reported by the U.S. Internal Revenue Service, Corporation Source Book, 2000 – 2008. Data were not available at disaggregated levels for all industries; OSHA used profit rates at more highly aggregated levels for such industries.

*Profit rate imputed from corresponding 3-digit NAICS industry.

**Profit rate imputed from corresponding 2-digit NAICS industry.

Source: U.S. Department of Labor, OSHA, Directorate of Standards and Guidance, Office of Regulatory Analysis-Safety.

Table V-33
Cost Impacts on Very Small Business Entities (Fewer than 20 Employees) Affected by OSHA's Final Revision
to Subparts D and I
(per Entity, by 4-Digit NAICS Code)

NAICS	Industry	Estimated Receipts, 2007 (\$1,000)[a]	Entities [b]	Average Receipts per Entity	Profit Rate [c]	Estimated Profits per Entity	Estimated Cost of the Final Rule	Average Cost per Entity	Ratio of Average Cost to Revenues	Ratio of Average Cost to Profits
1131	Timber Tract Operations	\$335,491	371	\$904,288	3.46% *	\$31,320	\$3,472	\$9.36	0.001%	0.030%
1132	Forest Nurseries and Gathering of Forest Products	\$102,025	154	\$662,500	3.46% *	\$22,946	\$1,603	\$10.41	0.002%	0.045%
1133	Logging	\$6,646,269	9,231	\$719,994	3.46% *	\$24,937	\$118,162	\$12.80	0.002%	0.051%
1141	Fishing	\$1,025,214	2,039	\$502,802	5.50% *	\$27,636	\$19,368	\$9.50	0.002%	0.034%
1142	Hunting and Trapping	\$91,616	312	\$293,641	5.50% *	\$16,140	\$2,974	\$9.53	0.003%	0.059%
1153	Support Activities for Forestry	\$598,327	1,528	\$391,575	4.60% *	\$18,011	\$17,473	\$11.44	0.003%	0.063%
2111	Oil and Gas Extraction	\$12,698,328	5,836	\$2,175,862	13.95%	\$303,627	\$363,229	\$62.24	0.003%	0.020%
2211	Electric Power Generation, Transmission and Distribution	\$8,364,773	630	\$13,277,417	4.33%	\$574,969	\$165,917	\$263.36	0.002%	0.046%
2212	Natural Gas Distribution	\$6,872,831	351	\$19,580,715	3.12%	\$611,604	\$23,257	\$66.26	0.000%	0.011%
2213	Water, Sewage and Other Systems	\$2,032,054	3,766	\$539,579	5.44%	\$29,349	\$12,918,006	\$3,430.17	0.636%	11.688%
3111	Animal Food Manufacturing	\$2,065,748	819	\$2,522,281	4.28%	\$107,861	\$116,158	\$141.83	0.006%	0.131%
3112	Grain and Oilseed Milling	\$1,071,553	277	\$3,868,422	4.28% *	\$165,427	\$43,318	\$156.38	0.004%	0.095%
3113	Sugar and Confectionery Product Manufacturing	\$929,203	1,587	\$585,509	7.74%	\$45,311	\$45,519	\$28.68	0.005%	0.063%
3114	Fruit and Vegetable Preserving and Specialty Food Manufacturing	\$1,176,242	684	\$1,719,652	6.70%	\$115,168	\$19,128	\$27.96	0.002%	0.024%
3115	Dairy Product Manufacturing	\$1,352,029	620	\$2,180,692	2.60%	\$56,706	\$23,329	\$37.63	0.002%	0.066%
3116	Animal Slaughtering and Processing	\$3,158,449	2,262	\$1,396,308	2.15%	\$30,024	\$1,288,628	\$569.69	0.041%	1.897%

Table V-33
Cost Impacts on Very Small Business Entities (Fewer than 20 Employees) Affected by OSHA's Final Revision
to Subparts D and I
(per Entity, by 4-Digit NAICS Code) (continued)

NAICS	Industry	Estimated Receipts, 2007 (\$1,000)[a]	Entities [b]	Average Receipts per Entity	Profit Rate [c]		Estimated Profits per Entity	Estimated Cost of the Final Rule	Average Cost per Entity	Ratio of Average Cost to Revenues	Ratio of Average Cost to Profits
3117	Seafood Product Preparation and Packaging	\$714,342	351	\$2,035,162	2.15%	*	\$43,761	\$9,316	\$26.54	0.001%	0.061%
3118	Bakeries and Tortilla Manufacturing	\$3,254,708	7,651	\$425,396	8.78%		\$37,346	\$265,090	\$34.65	0.008%	0.093%
3119	Other Food Manufacturing	\$2,874,924	1,786	\$1,609,700	5.36%		\$86,323	\$63,356	\$35.47	0.002%	0.041%
3121	Beverage Manufacturing	\$2,861,636	2,722	\$1,051,299	6.67%	*	\$70,136	\$78,796	\$28.95	0.003%	0.041%
3122	Tobacco Manufacturing	\$210,222	40	\$5,255,550	17.89%		\$939,974	\$5,482	\$137.04	0.003%	0.015%
3131	Fiber, Yarn, and Thread Mills	\$161,969	172	\$941,680	3.45%	*	\$32,473	\$8,288	\$48.19	0.005%	0.148%
3132	Fabric Mills	\$752,579	704	\$1,069,004	3.45%	*	\$36,864	\$16,980	\$24.12	0.002%	0.065%
3133	Textile and Fabric Finishing and Fabric Coating Mills	\$968,489	942	\$1,028,120	3.45%	*	\$35,454	\$84,783	\$90.00	0.009%	0.254%
3141	Textile Furnishings Mills	\$1,206,278	2,053	\$587,568	3.68%	*	\$21,597	\$159,838	\$77.86	0.013%	0.360%
3149	Other Textile Product Mills	\$1,796,901	3,302	\$544,186	3.68%	*	\$20,002	\$137,795	\$41.73	0.008%	0.209%
3151	Apparel Knitting Mills	\$239,222	283	\$845,307	2.87%		\$24,258	\$37,967	\$134.16	0.016%	0.553%
3152	Cut and Sew Apparel Manufacturing	\$4,656,884	7,163	\$650,130	5.00%		\$32,481	\$104,981	\$14.66	0.002%	0.045%
3159	Apparel Accessories and Other Apparel Manufacturing	\$345,953	730	\$473,908	3.92%		\$18,579	\$11,984	\$16.42	0.003%	0.088%
3161	Leather and Hide Tanning and Finishing	\$118,817	186	\$638,801	5.36%	*	\$34,212	\$4,645	\$24.97	0.004%	0.073%
3162	Footwear Manufacturing	\$147,147	206	\$714,306	5.36%	*	\$38,255	\$5,090	\$24.71	0.003%	0.065%
3169	Other Leather and Allied Product Manufacturing	\$364,186	682	\$533,997	5.36%	*	\$28,599	\$11,946	\$17.52	0.003%	0.061%
3211	Sawmills and Wood Preservation	\$2,832,987	2,626	\$1,078,822	2.86%	*	\$30,900	\$58,933	\$22.44	0.002%	0.073%

Table V-33
Cost Impacts on Very Small Business Entities (Fewer than 20 Employees) Affected by OSHA's Final Revision
to Subparts D and I
(per Entity, by 4-Digit NAICS Code) (continued)

NAICS	Industry	Estimated Receipts, 2007 (\$1,000)[a]	Entities [b]	Average Receipts per Entity	Profit Rate [c]	Estimated Profits per Entity	Estimated Cost of the Final Rule	Average Cost per Entity	Ratio of Average Cost to Revenues	Ratio of Average Cost to Profits
3212	Veneer, Plywood, and Engineered Wood Product Manufacturing	\$826,879	735	\$1,125,005	2.86% *	\$32,223	\$17,531	\$23.85	0.002%	0.074%
3219	Other Wood Product Manufacturing	\$5,497,108	6,913	\$795,184	2.86% *	\$22,776	\$142,413	\$20.60	0.003%	0.090%
3221	Pulp, Paper, and Paperboard Mills	\$171,342	85	\$2,015,788	3.36%	\$67,715	\$4,231	\$49.78	0.002%	0.074%
3222	Converted Paper Product Manufacturing	\$2,449,745	1,434	\$1,708,330	7.61%	\$129,981	\$48,017	\$33.48	0.002%	0.026%
3231	Printing and Related Support Activities	\$15,154,719	26,396	\$574,129	3.99% *	\$22,899	\$528,799	\$20.03	0.003%	0.087%
3241	Petroleum and Coal Products Manufacturing	\$2,630,614	696	\$3,779,618	7.34% *	\$277,280	\$40,301	\$57.90	0.002%	0.021%
3251	Basic Chemical Manufacturing	\$2,982,163	753	\$3,960,376	4.32%	\$171,027	\$34,499	\$45.82	0.001%	0.027%
3252	Resin, Synthetic Rubber, and Artificial Synthetic Fibers and Filaments Manufacturing	\$1,288,686	356	\$3,619,904	7.67%	\$277,596	\$18,727	\$52.60	0.001%	0.019%
3253	Pesticide, Fertilizer, and Other Agricultural Chemical Manufacturing	\$1,173,567	445	\$2,637,229	10.59% *	\$279,347	\$22,488	\$50.53	0.002%	0.018%
3254	Pharmaceutical and Medicine Manufacturing	\$1,748,241	852	\$2,051,926	15.76%	\$323,473	\$27,781	\$32.61	0.002%	0.010%
3255	Paint, Coating, and Adhesive Manufacturing	\$1,714,532	1,009	\$1,699,239	5.06%	\$85,916	\$28,434	\$28.18	0.002%	0.033%
3256	Soap, Cleaning Compound, and Toilet Preparation Manufacturing	\$4,456,775	1,419	\$3,140,786	9.72%	\$305,268	\$45,520	\$32.08	0.001%	0.011%

Table V-33
Cost Impacts on Very Small Business Entities (Fewer than 20 Employees) Affected by OSHA's Final Revision
to Subparts D and I
(per Entity, by 4-Digit NAICS Code) (continued)

NAICS	Industry	Estimated Receipts, 2007 (\$1,000)[a]	Entities [b]	Average Receipts per Entity	Profit Rate [c]	Estimated Profits per Entity	Estimated Cost of the Final Rule	Average Cost per Entity	Ratio of Average Cost to Revenues	Ratio of Average Cost to Profits
3259	Other Chemical Product and Preparation Manufacturing	\$2,270,151	1,476	\$1,538,043	4.88%	\$75,079	\$44,024	\$29.83	0.002%	0.040%
3261	Plastics Product Manufacturing	\$6,380,425	5,175	\$1,232,932	3.88%	\$47,797	\$117,239	\$22.65	0.002%	0.047%
3262	Rubber Product Manufacturing	\$1,016,240	961	\$1,057,482	2.28%	\$24,129	\$22,166	\$23.07	0.002%	0.096%
3271	Clay Product and Refractory Manufacturing	\$562,304	991	\$567,411	3.18%	\$18,031	\$24,988	\$25.22	0.004%	0.140%
3272	Glass and Glass Product Manufacturing	\$1,014,564	1,403	\$723,139	3.67%	\$26,553	\$40,229	\$28.67	0.004%	0.108%
3273	Cement and Concrete Product Manufacturing	\$4,685,193	3,200	\$1,464,123	5.39%	\$78,859	\$103,727	\$32.41	0.002%	0.041%
3274	Lime and Gypsum Product Manufacturing	\$249,479	150	\$1,663,193	5.39% *	\$89,582	\$9,884	\$65.90	0.004%	0.074%
3279	Other Nonmetallic Mineral Product Manufacturing	\$2,086,188	2,199	\$948,698	4.57% *	\$43,379	\$62,365	\$28.36	0.003%	0.065%
3311	Iron and Steel Mills and Ferroalloy Manufacturing	\$2,056,197	532	\$3,865,032	4.85%	\$187,594	\$21,759	\$40.90	0.001%	0.022%
3312	Steel Product Manufacturing from Purchased Steel	\$657,376	278	\$2,364,662	4.85% *	\$114,772	\$22,233	\$79.98	0.003%	0.070%
3313	Alumina and Aluminum Production and Processing	\$681,201	220	\$3,096,368	4.74%	\$146,819	\$8,652	\$39.33	0.001%	0.027%
3314	Nonferrous Metal (except Aluminum) Production and Processing	\$1,409,782	420	\$3,356,624	4.50% *	\$150,928	\$15,143	\$36.06	0.001%	0.024%
3315	Foundries	\$1,026,010	945	\$1,085,725	4.70%	\$51,021	\$29,036	\$30.73	0.003%	0.060%
3321	Forging and Stamping	\$1,579,508	1,237	\$1,276,886	4.60%	\$58,680	\$29,948	\$24.21	0.002%	0.041%
3322	Cutlery and Handtool Manufacturing	\$835,570	982	\$850,886	5.17%	\$44,029	\$24,435	\$24.88	0.003%	0.057%

Table V-33
Cost Impacts on Very Small Business Entities (Fewer than 20 Employees) Affected by OSHA's Final Revision
to Subparts D and I
(per Entity, by 4-Digit NAICS Code) (continued)

NAICS	Industry	Estimated Receipts, 2007 (\$1,000)[a]	Entities [b]	Average Receipts per Entity	Profit Rate [c]	Estimated Profits per Entity	Estimated Cost of the Final Rule	Average Cost per Entity	Ratio of Average Cost to Revenues	Ratio of Average Cost to Profits
3323	Architectural and Structural Metals Manufacturing	\$9,287,056	8,801	\$1,055,227	4.63%	\$48,813	\$192,805	\$21.91	0.002%	0.045%
3324	Boiler, Tank, and Shipping Container Manufacturing	\$930,447	650	\$1,431,457	3.69%	\$52,764	\$17,305	\$26.62	0.002%	0.050%
3325	Hardware Manufacturing	\$523,764	425	\$1,232,386	5.17% *	\$63,770	\$11,271	\$26.52	0.002%	0.042%
3326	Spring and Wire Product Manufacturing	\$891,955	918	\$971,629	5.17% *	\$50,277	\$29,673	\$32.32	0.003%	0.064%
3327	Machine Shops; Turned Product; and Screw, Nut, and Bolt Manufacturing	\$13,479,668	19,866	\$678,530	5.71% *	\$38,736	\$443,836	\$22.34	0.003%	0.058%
3328	Coating, Engraving, Heat Treating, and Allied Activities	\$3,589,774	3,891	\$922,584	4.59%	\$42,309	\$83,321	\$21.41	0.002%	0.051%
3329	Other Fabricated Metal Product Manufacturing	\$3,828,778	3,914	\$978,226	6.76%	\$66,171	\$90,917	\$23.23	0.002%	0.035%
3331	Agriculture, Construction, and Mining Machinery Manufacturing	\$2,415,764	1,698	\$1,422,711	6.07%	\$86,318	\$50,866	\$29.96	0.002%	0.035%
3332	Industrial Machinery Manufacturing	\$2,596,623	2,406	\$1,079,228	6.27%	\$67,625	\$57,265	\$23.80	0.002%	0.035%
3333	Commercial and Service Industry Machinery Manufacturing	\$1,703,014	1,427	\$1,193,423	4.56%	\$54,431	\$36,488	\$25.57	0.002%	0.047%
3334	Ventilation, Heating, Air-Conditioning, and Commercial Refrigeration Equipment Manufacturing	\$1,488,447	852	\$1,747,004	4.26%	\$74,387	\$20,194	\$23.70	0.001%	0.032%
3335	Metalworking Machinery Manufacturing	\$4,516,187	5,710	\$790,926	5.10%	\$40,343	\$140,209	\$24.56	0.003%	0.061%

Table V-33
Cost Impacts on Very Small Business Entities (Fewer than 20 Employees) Affected by OSHA's Final Revision
to Subparts D and I
(per Entity, by 4-Digit NAICS Code) (continued)

NAICS	Industry	Estimated Receipts, 2007 (\$1,000)[a]	Entities [b]	Average Receipts per Entity	Profit Rate [c]	Estimated Profits per Entity	Estimated Cost of the Final Rule	Average Cost per Entity	Ratio of Average Cost to Revenues	Ratio of Average Cost to Profits
3336	Engine, Turbine, and Power Transmission Equipment Manufacturing	\$674,860	412	\$1,638,010	2.67%	\$43,705	\$11,282	\$27.38	0.002%	0.063%
3339	Other General Purpose Machinery Manufacturing	\$4,485,758	3,478	\$1,289,752	4.94%	\$63,726	\$84,836	\$24.39	0.002%	0.038%
3341	Computer and Peripheral Equipment Manufacturing	\$1,184,942	861	\$1,376,239	8.55%	\$117,712	\$20,516	\$23.83	0.002%	0.020%
3342	Communications Equipment Manufacturing	\$1,214,742	970	\$1,252,311	4.50%	\$56,317	\$25,967	\$26.77	0.002%	0.048%
3343	Audio and Video Equipment Manufacturing	\$1,134,996	386	\$2,940,404	3.71%	\$108,977	\$9,458	\$24.50	0.001%	0.022%
3344	Semiconductor and Other Electronic Component Manufacturing	\$2,663,466	2,340	\$1,138,233	6.48%	\$73,790	\$62,019	\$26.50	0.002%	0.036%
3345	Navigational, Measuring, Electromedical, and Control Instruments Manufacturing	\$3,459,177	3,011	\$1,148,847	5.92%	\$68,043	\$73,363	\$24.36	0.002%	0.036%
3346	Manufacturing and Reproducing Magnetic and Optical Media	\$472,619	604	\$782,482	3.71% *	\$29,000	\$13,201	\$21.86	0.003%	0.075%
3351	Electric Lighting Equipment Manufacturing	\$757,044	739	\$1,024,417	4.08%	\$41,748	\$16,649	\$22.53	0.002%	0.054%
3352	Household Appliance Manufacturing	\$215,667	182	\$1,184,984	4.08%	\$48,292	\$16,513	\$90.73	0.008%	0.188%
3353	Electrical Equipment Manufacturing	\$1,609,761	1,349	\$1,193,299	6.93%	\$82,723	\$34,450	\$25.54	0.002%	0.031%
3359	Other Electrical Equipment and Component Manufacturing	\$1,396,826	1,053	\$1,326,520	5.01%	\$66,510	\$27,925	\$26.52	0.002%	0.040%

Table V-33
Cost Impacts on Very Small Business Entities (Fewer than 20 Employees) Affected by OSHA's Final Revision
to Subparts D and I
(per Entity, by 4-Digit NAICS Code) (continued)

NAICS	Industry	Estimated Receipts, 2007 (\$1,000)[a]	Entities [b]	Average Receipts per Entity	Profit Rate [c]	Estimated Profits per Entity	Estimated Cost of the Final Rule	Average Cost per Entity	Ratio of Average Cost to Revenues	Ratio of Average Cost to Profits
3361	Motor Vehicle Manufacturing	\$673,906	199	\$3,386,462	1.09%	\$36,805	\$8,377	\$42.10	0.001%	0.114%
3362	Motor Vehicle Body and Trailer Manufacturing	\$1,316,723	1,099	\$1,198,110	1.09%	\$13,022	\$26,013	\$23.67	0.002%	0.182%
3363	Motor Vehicle Parts Manufacturing	\$3,143,710	2,604	\$1,207,262	1.09%	\$13,121	\$61,697	\$23.69	0.002%	0.181%
3364	Aerospace Product and Parts Manufacturing	\$952,110	778	\$1,223,792	4.52%	\$55,362	\$23,745	\$30.52	0.002%	0.055%
3365	Railroad Rolling Stock Manufacturing	\$178,826	78	\$2,292,641	2.30%	\$52,760	\$5,005	\$64.16	0.003%	0.122%
3366	Ship and Boat Building	\$912,085	1,132	\$805,729	6.14%	\$49,451	\$49,509	\$43.74	0.005%	0.088%
3369	Other Transportation Equipment Manufacturing	\$870,578	787	\$1,106,198	6.07%	\$67,178	\$23,746	\$30.17	0.003%	0.045%
3371	Household and Institutional Furniture and Kitchen Cabinet Manufacturing	\$7,068,716	13,942	\$507,009	4.02%	\$20,371	\$256,512	\$18.40	0.004%	0.090%
3372	Office Furniture (including Fixtures) Manufacturing	\$2,187,158	2,542	\$860,408	4.02%	\$34,570	\$55,008	\$21.64	0.003%	0.063%
3379	Other Furniture Related Product Manufacturing	\$497,967	599	\$831,331	4.02%	\$33,402	\$12,149	\$20.28	0.002%	0.061%
3391	Medical Equipment and Supplies Manufacturing	\$4,979,198	9,679	\$514,433	9.84%	\$50,608	\$208,813	\$21.57	0.004%	0.043%
3399	Other Miscellaneous Manufacturing	\$10,214,575	15,011	\$680,473	5.38%	\$36,642	\$295,958	\$19.72	0.003%	0.054%
4231	Motor Vehicle and Motor Vehicle Parts and Supplies Merchant Wholesalers	\$33,451,668	14,357	\$2,329,990	2.25%	\$52,458	\$501,763	\$34.95	0.001%	0.067%
4232	Furniture and Home Furnishing Merchant Wholesalers	\$18,262,085	9,080	\$2,011,243	2.74%	\$55,103	\$179,423	\$19.76	0.001%	0.036%

Table V-33
Cost Impacts on Very Small Business Entities (Fewer than 20 Employees) Affected by OSHA's Final Revision
to Subparts D and I
(per Entity, by 4-Digit NAICS Code) (continued)

NAICS	Industry	Estimated Receipts, 2007 (\$1,000)[a]	Entities [b]	Average Receipts per Entity	Profit Rate [c]	Estimated Profits per Entity	Estimated Cost of the Final Rule	Average Cost per Entity	Ratio of Average Cost to Revenues	Ratio of Average Cost to Profits
4233	Lumber and Other Construction Materials Merchant Wholesalers	\$25,935,646	10,114	\$2,564,331	2.70%	\$69,186	\$293,753	\$29.04	0.001%	0.042%
4234	Professional and Commercial Equipment and Supplies Merchant Wholesalers	\$38,820,283	22,167	\$1,751,265	2.66%	\$46,583	\$771,584	\$34.81	0.002%	0.075%
4235	Metal and Mineral (except Petroleum) Merchant Wholesalers	\$32,860,040	5,660	\$5,805,661	2.79%	\$162,095	\$141,848	\$25.06	0.000%	0.015%
4236	Electrical and Electronic Goods Merchant Wholesalers	\$46,511,965	16,343	\$2,845,987	2.13%	\$60,589	\$501,217	\$30.67	0.001%	0.051%
4237	Hardware, and Plumbing and Heating Equipment and Supplies Merchant Wholesalers	\$19,118,111	8,995	\$2,125,415	3.18%	\$67,513	\$330,580	\$36.75	0.002%	0.054%
4238	Machinery, Equipment, and Supplies Merchant Wholesalers	\$80,469,787	35,458	\$2,269,440	3.49%	\$79,173	\$1,434,641	\$40.46	0.002%	0.051%
4239	Miscellaneous Durable Goods Merchant Wholesalers	\$63,584,707	27,588	\$2,304,796	2.74%	\$63,145	\$624,737	\$22.65	0.001%	0.036%
4241	Paper and Paper Product Merchant Wholesalers	\$13,922,220	7,623	\$1,826,344	2.02%	\$36,952	\$147,058	\$19.29	0.001%	0.052%
4242	Drugs and Druggists' Sundries Merchant Wholesalers	\$11,642,767	5,110	\$2,278,428	3.42%	\$78,004	\$95,993	\$18.79	0.001%	0.024%
4243	Apparel, Piece Goods, and Notions Merchant Wholesalers	\$27,245,980	13,010	\$2,094,234	4.68%	\$98,073	\$221,939	\$17.06	0.001%	0.017%

Table V-33
Cost Impacts on Very Small Business Entities (Fewer than 20 Employees) Affected by OSHA's Final Revision to Subparts D and I
(per Entity, by 4-Digit NAICS Code) (continued)

NAICS	Industry	Estimated Receipts, 2007 (\$1,000)[a]	Entities [b]	Average Receipts per Entity	Profit Rate [c]	Estimated Profits per Entity	Estimated Cost of the Final Rule	Average Cost per Entity	Ratio of Average Cost to Revenues	Ratio of Average Cost to Profits
4244	Grocery and Related Product Wholesalers	\$80,915,470	22,501	\$3,596,083	2.81%	\$101,027	\$472,400	\$20.99	0.001%	0.021%
4245	Farm Product Raw Material Merchant Wholesalers	\$25,139,956	3,154	\$7,970,817	2.03%	\$161,522	\$68,999	\$21.88	0.000%	0.014%
4246	Chemical and Allied Products Merchant Wholesalers	\$22,290,891	6,866	\$3,246,561	3.26%	\$105,785	\$195,123	\$28.42	0.001%	0.027%
4247	Petroleum and Petroleum Products Merchant Wholesalers	\$45,454,555	3,322	\$13,682,888	1.90%	\$259,797	\$149,032	\$44.86	0.000%	0.017%
4248	Beer, Wine, and Distilled Alcoholic Beverage Merchant Wholesalers	\$5,130,058	2,034	\$2,522,152	3.77%	\$95,079	\$46,415	\$22.82	0.001%	0.024%
4249	Miscellaneous Nondurable Goods Merchant Wholesalers	\$42,740,152	22,114	\$1,932,719	2.93%	\$56,687	\$415,471	\$18.79	0.001%	0.033%
4251	Wholesale Electronic Markets and Agents and Brokers	\$238,856,931	51,680	\$4,621,845	7.55%	\$349,068	\$1,352,827	\$26.18	0.001%	0.007%
4411	Automobile Dealers	\$76,951,315	31,917	\$2,410,982	0.98%	\$23,559	\$976,862	\$30.61	0.001%	0.130%
4412	Other Motor Vehicle Dealers	\$24,554,359	13,141	\$1,868,530	2.52%	\$47,116	\$361,426	\$27.50	0.001%	0.058%
4413	Automotive Parts, Accessories, and Tire Stores	\$23,913,475	30,240	\$790,790	1.24%	\$9,821	\$751,181	\$24.84	0.003%	0.253%
4421	Furniture Stores	\$16,108,088	18,005	\$894,645	3.06%	\$27,337	\$325,614	\$18.08	0.002%	0.066%
4422	Home Furnishings Stores	\$19,194,753	24,937	\$769,730	3.06%	\$23,520	\$533,143	\$21.38	0.003%	0.091%
4431	Electronics and Appliance Stores	\$21,198,389	28,687	\$738,955	3.29%	\$24,298	\$658,984	\$22.97	0.003%	0.095%
4441	Building Material and Supplies Dealers	\$44,680,922	38,531	\$1,159,610	7.66%	\$88,863	\$985,880	\$25.59	0.002%	0.029%

Table V-33
Cost Impacts on Very Small Business Entities (Fewer than 20 Employees) Affected by OSHA's Final Revision
to Subparts D and I
(per Entity, by 4-Digit NAICS Code) (continued)

NAICS	Industry	Estimated Receipts, 2007 (\$1,000)[a]	Entities [b]	Average Receipts per Entity	Profit Rate [c]		Estimated Profits per Entity	Estimated Cost of the Final Rule	Average Cost per Entity	Ratio of Average Cost to Revenues	Ratio of Average Cost to Profits
4442	Lawn and Garden Equipment and Supplies Stores	\$15,823,886	14,726	\$1,074,554	1.81%	**	\$19,406	\$333,394	\$22.64	0.002%	0.117%
4451	Grocery Stores	\$42,786,245	57,220	\$747,750	2.00%	*	\$14,973	\$672,311	\$11.75	0.002%	0.078%
4452	Specialty Food Stores	\$11,369,036	21,967	\$517,551	2.00%	*	\$10,363	\$298,109	\$13.57	0.003%	0.131%
4453	Beer, Wine, and Liquor Stores	\$23,311,870	26,079	\$893,894	2.07%	*	\$18,494	\$309,639	\$11.87	0.001%	0.064%
4461	Health and Personal Care Stores	\$51,251,763	39,978	\$1,281,999	3.06%	*	\$39,178	\$546,497	\$13.67	0.001%	0.035%
4471	Gasoline Stations	\$136,136,010	60,944	\$2,233,789	0.86%	*	\$19,168	\$1,422,279	\$23.34	0.001%	0.122%
4481	Clothing Stores	\$19,159,562	38,954	\$491,851	5.15%	*	\$25,335	\$581,858	\$14.94	0.003%	0.059%
4482	Shoe Stores	\$3,686,713	6,177	\$596,845	5.15%	*	\$30,743	\$63,979	\$10.36	0.002%	0.034%
4483	Jewelry, Luggage, and Leather Goods Stores	\$13,320,887	18,537	\$718,611	5.15%	*	\$37,015	\$333,541	\$17.99	0.003%	0.049%
4511	Sporting Goods, Hobby, and Musical Instrument Stores	\$16,513,942	30,028	\$549,951	2.62%	*	\$14,401	\$576,122	\$19.19	0.003%	0.133%
4512	Book, Periodical, and Music Stores	\$3,370,695	8,449	\$398,946	2.62%	*	\$10,447	\$115,897	\$13.72	0.003%	0.131%
4521	Department Stores	\$153,401	340	\$451,179	4.15%	*	\$18,719	\$5,661	\$16.65	0.004%	0.089%
4529	Other General Merchandise Stores	\$4,396,395	9,408	\$467,304	4.15%	*	\$19,388	\$162,282	\$17.25	0.004%	0.089%
4531	Florists	\$5,114,023	18,405	\$277,861	3.23%	*	\$8,972	\$201,905	\$10.97	0.004%	0.122%
4532	Office Supplies, Stationery, and Gift Stores	\$10,315,311	27,053	\$381,300	3.23%	*	\$12,312	\$428,235	\$15.83	0.004%	0.129%
4533	Used Merchandise Stores	\$4,674,662	12,084	\$386,847	3.23%	*	\$12,491	\$176,952	\$14.64	0.004%	0.117%
4539	Other Miscellaneous Store Retailers	\$27,496,826	35,066	\$784,145	3.23%	*	\$25,319	\$763,589	\$21.78	0.003%	0.086%
4541	Electronic Shopping and Mail-Order Houses	\$15,013,728	13,757	\$1,091,352	3.75%	*	\$40,953	\$197,881	\$14.38	0.001%	0.035%

Table V-33
Cost Impacts on Very Small Business Entities (Fewer than 20 Employees) Affected by OSHA's Final Revision
to Subparts D and I
(per Entity, by 4-Digit NAICS Code) (continued)

NAICS	Industry	Estimated Receipts, 2007 (\$1,000)[a]	Entities [b]	Average Receipts per Entity	Profit Rate [c]		Estimated Profits per Entity	Estimated Cost of the Final Rule	Average Cost per Entity	Ratio of Average Cost to Revenues	Ratio of Average Cost to Profits
4542	Vending Machine Operators	\$2,148,565	4,200	\$511,563	3.75%	*	\$19,196	\$139,090	\$33.12	0.006%	0.173%
4543	Direct Selling Establishments	\$20,664,119	18,151	\$1,138,456	3.75%	*	\$42,720	\$450,544	\$24.82	0.002%	0.058%
4811	Scheduled Air Transportation	\$537,306	375	\$1,432,816	2.57%	*	\$36,799	\$15,926	\$42.47	0.003%	0.115%
4812	Nonscheduled Air Transportation	\$2,249,805	1,966	\$1,144,357	2.57%	*	\$29,391	\$167,459	\$85.18	0.007%	0.290%
4831	Deep Sea, Coastal, and Great Lakes Water Transportation	\$1,172,391	629	\$1,863,897	6.37%	*	\$118,657	\$126,034	\$200.37	0.011%	0.169%
4832	Inland Water Transportation	\$486,388	465	\$1,045,996	6.21%	*	\$64,946	\$143,621	\$308.86	0.030%	0.476%
4841	General Freight Trucking	\$28,653,374	53,000	\$540,630	6.21%	*	\$33,568	\$1,031,369	\$19.46	0.004%	0.058%
4842	Specialized Freight Trucking	\$24,476,198	43,755	\$559,392	2.51%	*	\$14,065	\$887,392	\$20.28	0.004%	0.144%
4851	Urban Transit Systems	\$170,505	408	\$417,904	2.51%	*	\$10,508	\$34,651	\$84.93	0.020%	0.808%
4852	Interurban and Rural Bus Transportation	\$71,672	156	\$459,436	2.13%	*	\$9,784	\$12,140	\$77.82	0.017%	0.795%
4853	Taxi and Limousine Service	\$2,123,731	6,692	\$317,354	2.13%	*	\$6,758	\$137,453	\$20.54	0.006%	0.304%
4854	School and Employee Bus Transportation	\$516,198	2,107	\$244,992	2.13%	*	\$5,217	\$83,737	\$39.74	0.016%	0.762%
4855	Charter Bus Industry	\$415,346	776	\$535,240	2.13%	*	\$11,398	\$28,219	\$36.37	0.007%	0.319%
4859	Other Transit and Ground Passenger Transportation	\$813,347	2,464	\$330,092	2.13%	*	\$7,029	\$85,492	\$34.70	0.011%	0.494%
4861	Pipeline Transportation of Crude Oil	\$43,441	28	\$1,551,464	13.23%	*	\$205,250	\$2,660	\$95.00	0.006%	0.046%
4862	Pipeline Transportation of Natural Gas	\$226,559	63	\$3,596,167	13.23%	*	\$475,752	\$5,338	\$84.73	0.002%	0.018%
4869	Other Pipeline Transportation	\$77,499	35	\$2,214,257	13.23%	*	\$292,933	\$1,900	\$54.30	0.002%	0.019%
4871	Scenic and Sightseeing Transportation, Land	\$240,790	536	\$449,235	13.23%	*	\$59,431	\$13,258	\$24.73	0.006%	0.042%

Table V-33
Cost Impacts on Very Small Business Entities (Fewer than 20 Employees) Affected by OSHA's Final Revision
to Subparts D and I
(per Entity, by 4-Digit NAICS Code) (continued)

NAICS	Industry	Estimated Receipts, 2007 (\$1,000)[a]	Entities [b]	Average Receipts per Entity	Profit Rate [c]		Estimated Profits per Entity	Estimated Cost of the Final Rule	Average Cost per Entity	Ratio of Average Cost to Revenues	Ratio of Average Cost to Profits
4872	Scenic and Sightseeing Transportation, Water	\$635,038	1,717	\$369,853	4.42%	*	\$16,360	\$57,923	\$33.74	0.009%	0.206%
4879	Scenic and Sightseeing Transportation, Other	\$96,661	171	\$565,269	4.42%	*	\$25,004	\$8,701	\$50.88	0.009%	0.203%
4881	Support Activities for Air Transportation	\$2,270,226	3,385	\$670,672	4.42%	**	\$29,667	\$215,904	\$63.78	0.010%	0.215%
4882	Support Activities for Rail Transportation	\$353,878	335	\$1,056,352	3.19%	**	\$33,709	\$40,621	\$121.26	0.011%	0.360%
4883	Support Activities for Water Transportation	\$1,183,478	1,404	\$842,933	3.19%	**	\$26,899	\$57,447	\$40.92	0.005%	0.152%
4884	Support Activities for Road Transportation	\$3,568,487	8,660	\$412,065	3.19%	**	\$13,149	\$264,757	\$30.57	0.007%	0.233%
4885	Freight Transportation Arrangement	\$13,522,609	11,567	\$1,169,068	3.19%	**	\$37,306	\$243,147	\$21.02	0.002%	0.056%
4889	Other Support Activities for Transportation	\$667,588	1,381	\$483,409	3.19%	**	\$15,426	\$21,040	\$15.24	0.003%	0.099%
4921	Couriers	\$1,561,375	3,321	\$470,152	3.19%	**	\$15,003	\$75,774	\$22.82	0.005%	0.152%
4922	Local Messengers and Local Delivery	\$1,649,091	3,918	\$420,901	3.19%	**	\$13,431	\$68,183	\$17.40	0.004%	0.130%
4931	Warehousing and Storage	\$3,746,452	3,827	\$978,953	4.59%	*	\$44,915	\$81,179	\$21.21	0.002%	0.047%
5111	Newspaper, Periodical, Book, and Directory Publishers	\$8,965,402	14,080	\$636,747	11.69%	*	\$74,406	\$313,825	\$22.29	0.004%	0.030%
5112	Software Publishers	\$4,271,962	4,524	\$944,289	16.22%	*	\$153,175	\$163,281	\$36.09	0.004%	0.024%
5121	Motion Picture and Video Industries	\$11,216,140	16,359	\$685,625	6.24%	**	\$42,752	\$368,305	\$22.51	0.003%	0.053%
5122	Sound Recording Industries	\$1,654,218	3,425	\$482,983	7.26%	**	\$35,081	\$206,089	\$60.17	0.012%	0.172%
5151	Radio and Television Broadcasting	\$1,956,657	3,621	\$540,364	6.79%	*	\$36,665	\$137,264	\$37.91	0.007%	0.103%

Table V-33
Cost Impacts on Very Small Business Entities (Fewer than 20 Employees) Affected by OSHA's Final Revision
to Subparts D and I
(per Entity, by 4-Digit NAICS Code) (continued)

NAICS	Industry	Estimated Receipts, 2007 (\$1,000)[a]	Entities [b]	Average Receipts per Entity	Profit Rate [c]	Estimated Profits per Entity	Estimated Cost of the Final Rule	Average Cost per Entity	Ratio of Average Cost to Revenues	Ratio of Average Cost to Profits
5152	Cable and Other Subscription Programming	\$445,376	293	\$1,520,055	6.79% *	\$103,139	\$92,702	\$316.39	0.021%	0.307%
5161	Internet Publishing and Broadcasting	\$1,339,867	2,074	\$646,030	7.06% *	\$45,609	\$157,333	\$75.86	0.012%	0.166%
5171	Wired Telecommunications Carriers	\$1,935,085	1,393	\$1,389,149	6.40% *	\$88,955	\$115,886	\$83.19	0.006%	0.094%
5172	Wireless Telecommunications Carriers (except Satellite)	\$1,222,843	1,452	\$842,178	6.40% *	\$53,929	\$56,728	\$39.07	0.005%	0.072%
5173	Telecommunications Resellers	\$3,308,774	2,789	\$1,186,366	6.40% *	\$75,970	\$320,493	\$114.91	0.010%	0.151%
5174	Satellite Telecommunications	\$545,539	478	\$1,141,295	6.40% *	\$73,084	\$145,413	\$304.21	0.027%	0.416%
5175	Cable and Other Program Distribution	\$764,231	802	\$952,906	6.40% *	\$61,020	\$42,280	\$52.72	0.006%	0.086%
5179	Other Telecommunications	\$916,967	1,176	\$779,734	6.40% *	\$49,931	\$174,645	\$148.51	0.019%	0.297%
5181	Internet Service Providers and Web Search Portals	\$2,172,820	3,350	\$648,603	7.21% *	\$46,756	\$177,233	\$52.91	0.008%	0.113%
5182	Data Processing, Hosting, and Related Services	\$4,575,616	6,048	\$756,550	7.21% *	\$54,537	\$151,854	\$25.11	0.003%	0.046%
5191	Other Information Services	\$1,136,006	2,988	\$380,189	8.78% *	\$33,379	\$168,039	\$56.24	0.015%	0.168%
5211	Monetary Authorities - Central Bank	\$63,481	39	\$1,627,718	5.83% *	\$94,958	\$3,874	\$99.32	0.006%	0.105%
5221	Depository Credit Intermediation	\$10,303,960	7,589	\$1,357,749	9.42% *	\$127,843	\$93,962	\$12.38	0.001%	0.010%
5222	Nondepository Credit Intermediation	\$15,089,018	20,967	\$719,656	7.53% *	\$54,224	\$213,631	\$10.19	0.001%	0.019%
5223	Activities Related to Credit Intermediation	\$11,348,802	26,119	\$434,504	10.33% **	\$44,887	\$285,342	\$10.92	0.003%	0.024%

Table V-33
Cost Impacts on Very Small Business Entities (Fewer than 20 Employees) Affected by OSHA's Final Revision
to Subparts D and I
(per Entity, by 4-Digit NAICS Code) (continued)

NAICS	Industry	Estimated Receipts, 2007 (\$1,000)[a]	Entities [b]	Average Receipts per Entity	Profit Rate [c]	Estimated Profits per Entity	Estimated Cost of the Final Rule	Average Cost per Entity	Ratio of Average Cost to Revenues	Ratio of Average Cost to Profits
5231	Securities and Commodity Contracts Intermediation and Brokerage	\$12,849,193	12,049	\$1,066,412	5.99% *	\$63,835	\$138,785	\$11.52	0.001%	0.018%
5232	Securities and Commodity Exchanges	\$102,641	107	\$959,265	5.99% *	\$57,422	\$2,830	\$26.45	0.003%	0.046%
5239	Other Financial Investment Activities	\$38,925,295	42,067	\$925,317	31.09% *	\$287,637	\$440,498	\$10.47	0.001%	0.004%
5241	Insurance Carriers	\$7,474,769	6,199	\$1,205,802	4.56% *	\$55,018	\$75,082	\$12.11	0.001%	0.022%
5242	Agencies, Brokerages, and Other Insurance Related Activities	\$51,149,567	126,015	\$405,901	4.56% *	\$18,520	\$1,115,783	\$8.85	0.002%	0.048%
5259	Other Investment Pools and Funds	\$4,149,107	1,965	\$2,111,505	65.69% *	\$1,386,955	\$28,360	\$14.43	0.001%	0.001%
5311	Lessors of Real Estate	\$62,856,475	91,585	\$686,318	13.62% *	\$93,467	\$1,452,695	\$15.86	0.002%	0.017%
5312	Offices of Real Estate Agents and Brokers	\$49,266,887	100,495	\$490,242	8.22% *	\$40,291	\$1,071,829	\$10.67	0.002%	0.026%
5313	Activities Related to Real Estate	\$26,694,360	68,879	\$387,554	13.62% *	\$52,779	\$949,172	\$13.78	0.004%	0.026%
5321	Automotive Equipment Rental and Leasing	\$3,112,600	4,140	\$751,836	2.43% **	\$18,296	\$47,935	\$11.58	0.002%	0.063%
5322	Consumer Goods Rental	\$3,801,386	10,893	\$348,975	3.69% *	\$12,874	\$113,211	\$10.39	0.003%	0.081%
5323	General Rental Centers	\$1,842,468	2,867	\$642,647	3.69% *	\$23,707	\$42,492	\$14.82	0.002%	0.063%
5324	Commercial and Industrial Machinery and Equipment Rental and Leasing	\$7,140,211	7,207	\$990,733	5.35% **	\$53,022	\$103,379	\$14.34	0.001%	0.027%
5331	Lessors of Nonfinancial Intangible Assets (except Copyrighted Works)	\$3,197,850	2,051	\$1,559,166	29.11% *	\$453,819	\$16,335	\$7.96	0.001%	0.002%

Table V-33
Cost Impacts on Very Small Business Entities (Fewer than 20 Employees) Affected by OSHA's Final Revision
to Subparts D and I
(per Entity, by 4-Digit NAICS Code) (continued)

NAICS	Industry	Estimated Receipts, 2007 (\$1,000)[a]	Entities [b]	Average Receipts per Entity	Profit Rate [c]	Estimated Profits per Entity	Estimated Cost of the Final Rule	Average Cost per Entity	Ratio of Average Cost to Revenues	Ratio of Average Cost to Profits
5411	Legal Services	\$86,321,366	173,334	\$498,006	8.86% **	\$44,144	\$2,043,531	\$11.79	0.002%	0.027%
5412	Accounting, Tax Preparation, Bookkeeping, and Payroll Services	\$31,004,051	101,937	\$304,149	7.81% **	\$23,756	\$1,289,515	\$12.65	0.004%	0.053%
5413	Architectural, Engineering, and Related Services	\$49,779,421	90,424	\$550,511	4.79% **	\$26,342	\$1,571,948	\$17.38	0.003%	0.066%
5414	Specialized Design Services	\$16,869,744	33,480	\$503,875	5.48% **	\$27,600	\$470,029	\$14.04	0.003%	0.051%
5415	Computer Systems Design and Related Services	\$47,470,852	96,593	\$491,452	5.02% **	\$24,655	\$1,391,906	\$14.41	0.003%	0.058%
5416	Management, Scientific, and Technical Consulting Services	\$62,747,767	136,280	\$460,433	7.49% **	\$34,483	\$1,926,990	\$14.14	0.003%	0.041%
5417	Scientific Research and Development Services	\$8,652,898	10,974	\$788,491	2.14% **	\$16,903	\$233,457	\$21.27	0.003%	0.126%
5418	Advertising and Related Services	\$25,585,465	33,795	\$757,078	5.13% **	\$38,867	\$6,589,286	\$194.98	0.026%	0.502%
5419	Other Professional, Scientific, and Technical Services	\$28,685,212	59,528	\$481,878	6.72% **	\$32,389	\$709,639	\$11.92	0.002%	0.037%
5511	Management of Companies and Enterprises	\$9,968,751	5,719	\$1,743,093	6.72% **	\$117,161	\$92,777	\$16.22	0.001%	0.014%
5611	Office Administrative Services	\$14,369,977	22,481	\$639,205	12.73% *	\$81,381	\$339,828	\$15.12	0.002%	0.019%
5612	Facilities Support Services	\$1,024,783	978	\$1,047,835	4.21% *	\$44,071	\$22,864	\$23.38	0.002%	0.053%
5613	Employment Services	\$6,422,772	14,288	\$449,522	4.21% **	\$18,906	\$185,941	\$13.01	0.003%	0.069%
5614	Business Support Services	\$11,223,697	25,890	\$433,515	2.66% *	\$11,549	\$298,570	\$11.53	0.003%	0.100%
5615	Travel Arrangement and Reservation Services	\$6,855,300	15,806	\$433,715	4.21% **	\$18,242	\$154,950	\$9.80	0.002%	0.054%

Table V-33
Cost Impacts on Very Small Business Entities (Fewer than 20 Employees) Affected by OSHA's Final Revision
to Subparts D and I
(per Entity, by 4-Digit NAICS Code) (continued)

NAICS	Industry	Estimated Receipts, 2007 (\$1,000)[a]	Entities [b]	Average Receipts per Entity	Profit Rate [c]		Estimated Profits per Entity	Estimated Cost of the Final Rule	Average Cost per Entity	Ratio of Average Cost to Revenues	Ratio of Average Cost to Profits
5616	Investigation and Security Services	\$6,349,455	16,410	\$386,926	3.30%	*	\$12,779	\$234,090	\$14.27	0.004%	0.112%
5617	Services to Buildings and Dwellings	\$46,551,737	160,667	\$289,741	4.21%	*	\$12,186	\$82,401,545	\$512.87	0.177%	4.209%
5619	Other Support Services	\$11,505,781	16,611	\$692,660	4.21%	*	\$29,132	\$236,800	\$14.26	0.002%	0.049%
5621	Waste Collection	\$5,000,141	6,550	\$763,380	5.44%	*	\$41,531	\$116,202	\$17.74	0.002%	0.043%
5622	Waste Treatment and Disposal	\$1,332,275	1,277	\$1,043,285	4.79%	*	\$49,948	\$51,484	\$40.32	0.004%	0.081%
5629	Remediation and Other Waste Management Services	\$4,410,114	6,739	\$654,417	4.79%	*	\$31,330	\$137,596	\$20.42	0.003%	0.065%
6111	Elementary and Secondary Schools	\$3,918,185	8,116	\$482,773	7.60%	**	\$36,710	\$115,800	\$14.27	0.003%	0.039%
6112	Junior Colleges	\$124,349	176	\$706,528	7.60%	**	\$53,724	\$10,162	\$57.74	0.008%	0.107%
6113	Colleges, Universities, and Professional Schools	\$604,290	868	\$696,187	7.60%	**	\$52,937	\$12,509	\$14.41	0.002%	0.027%
6114	Business Schools and Computer and Management Training	\$3,173,380	6,367	\$498,411	7.60%	**	\$37,899	\$79,074	\$12.42	0.002%	0.033%
6115	Technical and Trade Schools	\$2,641,692	5,671	\$465,825	7.60%	**	\$35,421	\$91,412	\$16.12	0.003%	0.046%
6116	Other Schools and Instruction	\$7,652,439	32,864	\$232,852	7.60%	**	\$17,706	\$361,383	\$11.00	0.005%	0.062%
6117	Educational Support Services	\$2,292,614	5,525	\$414,953	7.60%	**	\$31,553	\$71,774	\$12.99	0.003%	0.041%
6211	Offices of Physicians	\$129,926,765	173,483	\$748,931	4.56%	*	\$34,122	\$1,649,307	\$9.51	0.001%	0.028%
6212	Offices of Dentists	\$77,594,755	116,943	\$663,526	7.66%	*	\$50,813	\$1,121,750	\$9.59	0.001%	0.019%
6213	Offices of Other Health Practitioners	\$34,382,489	108,837	\$315,908	7.78%	*	\$24,593	\$935,956	\$8.60	0.003%	0.035%
6214	Outpatient Care Centers	\$6,227,506	9,406	\$662,078	5.34%	*	\$35,366	\$119,111	\$12.66	0.002%	0.036%

Table V-33
Cost Impacts on Very Small Business Entities (Fewer than 20 Employees) Affected by OSHA's Final Revision
to Subparts D and I
(per Entity, by 4-Digit NAICS Code) (continued)

NAICS	Industry	Estimated Receipts, 2007 (\$1,000)[a]	Entities [b]	Average Receipts per Entity	Profit Rate [c]		Estimated Profits per Entity	Estimated Cost of the Final Rule	Average Cost per Entity	Ratio of Average Cost to Revenues	Ratio of Average Cost to Profits
6215	Medical and Diagnostic Laboratories	\$5,832,723	6,099	\$956,341	5.51%	*	\$52,732	\$69,165	\$11.34	0.001%	0.022%
6216	Home Health Care Services	\$3,547,660	9,898	\$358,422	5.51%	*	\$19,763	\$107,935	\$10.90	0.003%	0.055%
6219	Other Ambulatory Health Care Services	\$2,165,857	4,056	\$533,988	5.51%	*	\$29,444	\$47,304	\$11.66	0.002%	0.040%
6221	General Medical and Surgical Hospitals	\$346,216	170	\$2,036,565	5.24%	**	\$106,700	\$2,166	\$12.74	0.001%	0.012%
6222	Psychiatric and Substance Abuse Hospitals	\$75,942	95	\$799,389	5.24%	**	\$41,882	\$1,267	\$13.33	0.002%	0.032%
6223	Specialty (except Psychiatric and Substance Abuse) Hospitals	\$165,024	236	\$699,254	5.24%	**	\$36,635	\$3,975	\$16.84	0.002%	0.046%
6231	Nursing Care Facilities	\$1,277,862	1,768	\$722,773	5.24%	**	\$37,868	\$14,693	\$8.31	0.001%	0.022%
6232	Residential Mental Retardation, Mental Health and Substance Abuse Facilities	\$1,334,305	4,311	\$309,512	5.24%	**	\$16,216	\$34,460	\$7.99	0.003%	0.049%
6233	Community Care Facilities for the Elderly	\$2,816,143	10,036	\$280,604	5.24%	**	\$14,701	\$81,308	\$8.10	0.003%	0.055%
6239	Other Residential Care Facilities	\$640,339	2,018	\$317,314	5.24%	**	\$16,625	\$17,430	\$8.64	0.003%	0.052%
6241	Individual and Family Services	\$11,026,791	30,530	\$361,179	5.24%	**	\$18,923	\$281,337	\$9.22	0.003%	0.049%
6242	Community Food and Housing, and Emergency and Other Relief Services	\$4,921,088	6,950	\$708,070	5.24%	**	\$37,097	\$61,117	\$8.79	0.001%	0.024%
6243	Vocational Rehabilitation Services	\$941,893	2,096	\$449,376	5.24%	**	\$23,544	\$15,529	\$7.41	0.002%	0.031%
6244	Child Day Care Services	\$8,780,725	49,092	\$178,863	5.24%	**	\$9,371	\$361,559	\$7.36	0.004%	0.079%

Table V-33
Cost Impacts on Very Small Business Entities (Fewer than 20 Employees) Affected by OSHA's Final Revision
to Subparts D and I
(per Entity, by 4-Digit NAICS Code) (continued)

NAICS	Industry	Estimated Receipts, 2007 (\$1,000)[a]	Entities [b]	Average Receipts per Entity	Profit Rate [c]	Estimated Profits per Entity	Estimated Cost of the Final Rule	Average Cost per Entity	Ratio of Average Cost to Revenues	Ratio of Average Cost to Profits
7111	Performing Arts Companies	\$4,788,609	8,161	\$586,767	8.99% *	\$52,732	\$785,913	\$96.30	0.016%	0.183%
7112	Spectator Sports	\$2,209,037	3,798	\$581,632	8.99% *	\$52,270	\$78,768	\$20.74	0.004%	0.040%
7113	Promoters of Performing Arts, Sports, and Similar Events	\$4,115,319	5,395	\$762,802	8.99% *	\$68,552	\$166,947	\$30.94	0.004%	0.045%
7114	Agents and Managers for Artists, Athletes, Entertainers, and Other Public Figures	\$2,588,703	3,511	\$737,312	8.99% *	\$66,261	\$44,123	\$12.57	0.002%	0.019%
7115	Independent Artists, Writers, and Performers	\$11,280,670	19,734	\$571,636	8.99% *	\$51,372	\$209,715	\$10.63	0.002%	0.021%
7121	Museums, Historical Sites, and Similar Institutions	\$2,170,237	5,711	\$380,010	6.69% **	\$25,408	\$61,819	\$10.82	0.003%	0.043%
7131	Amusement Parks and Arcades	\$882,679	2,108	\$418,728	4.94% *	\$20,701	\$30,691	\$14.56	0.003%	0.070%
7132	Gambling Industries	\$1,189,840	1,466	\$811,623	4.94% *	\$40,124	\$15,208	\$10.37	0.001%	0.026%
7139	Other Amusement and Recreation Industries	\$16,815,436	50,769	\$331,215	4.94% *	\$16,374	\$571,007	\$11.25	0.003%	0.069%
7211	Traveler Accommodation	\$16,791,521	33,973	\$494,261	5.14% *	\$25,408	\$402,878	\$11.86	0.002%	0.047%
7212	RV (Recreational Vehicle) Parks and Recreational Camps	\$2,708,188	6,233	\$434,492	5.14% *	\$22,335	\$72,991	\$11.71	0.003%	0.052%
7213	Rooming and Boarding Houses	\$602,779	2,034	\$296,352	5.14% *	\$15,234	\$23,605	\$11.61	0.004%	0.076%
7221	Full-Service Restaurants	\$46,000,251	141,430	\$325,251	4.61% *	\$14,981	\$1,237,649	\$8.75	0.003%	0.058%
7222	Limited-Service Eating Places	\$41,062,798	141,803	\$289,576	4.61% *	\$13,338	\$1,183,552	\$8.35	0.003%	0.063%
7223	Special Food Services	\$4,347,542	12,836	\$338,699	4.61% *	\$15,600	\$153,837	\$11.98	0.004%	0.077%

Table V-33
Cost Impacts on Very Small Business Entities (Fewer than 20 Employees) Affected by OSHA's Final Revision
to Subparts D and I
(per Entity, by 4-Digit NAICS Code) (continued)

NAICS	Industry	Estimated Receipts, 2007 (\$1,000)[a]	Entities [b]	Average Receipts per Entity	Profit Rate [c]		Estimated Profits per Entity	Estimated Cost of the Final Rule	Average Cost per Entity	Ratio of Average Cost to Revenues	Ratio of Average Cost to Profits
7224	Drinking Places (Alcoholic Beverages)	\$11,021,710	42,226	\$261,017	4.61%	*	\$12,022	\$384,773	\$9.11	0.003%	0.076%
8111	Automotive Repair and Maintenance	\$61,365,164	146,321	\$419,387	3.25%	*	\$13,636	\$3,235,699	\$22.11	0.005%	0.162%
8112	Electronic and Precision Equipment Repair and Maintenance	\$4,809,092	10,607	\$453,389	4.90%	*	\$22,226	\$195,806	\$18.46	0.004%	0.083%
8113	Commercial and Industrial Machinery and Equipment (except Automotive and Electronic) Repair and Maintenance	\$11,472,207	20,429	\$561,565	4.90%	*	\$27,529	\$425,170	\$20.81	0.004%	0.076%
8114	Personal and Household Goods Repair and Maintenance	\$5,893,106	21,460	\$274,609	4.90%	*	\$13,462	\$304,497	\$14.19	0.005%	0.105%
8121	Personal Care Services	\$15,098,462	92,503	\$163,221	5.12%	*	\$8,351	\$685,594	\$7.41	0.005%	0.089%
8122	Death Care Services	\$8,487,669	14,826	\$572,485	5.12%	*	\$29,289	\$146,612	\$9.89	0.002%	0.034%
8123	Dry-cleaning and Laundry Services	\$7,395,375	31,666	\$233,543	5.12%	*	\$11,948	\$315,321	\$9.96	0.004%	0.083%
8129	Other Personal Services	\$6,445,815	24,514	\$262,944	5.12%	*	\$13,452	\$284,152	\$11.59	0.004%	0.086%
8131	Religious Organizations	\$49,432,764	162,152	\$304,854	2.05%	*	\$6,246	\$1,467,465	\$9.05	0.003%	0.145%
8132	Grantmaking and Giving Services	\$37,560,115	14,131	\$2,657,994	2.05%	*	\$54,459	\$145,943	\$10.33	0.000%	0.019%
8133	Social Advocacy Organizations	\$6,178,824	11,696	\$528,285	2.05%	*	\$10,824	\$116,396	\$9.95	0.002%	0.092%
8134	Civic and Social Organizations	\$8,291,139	24,642	\$336,464	2.05%	*	\$6,894	\$271,138	\$11.00	0.003%	0.160%

Table V-33
Cost Impacts on Very Small Business Entities (Fewer than 20 Employees) Affected by OSHA's Final Revision to Subparts D and I
(per Entity, by 4-Digit NAICS Code) (continued)

NAICS	Industry	Estimated Receipts, 2007 (\$1,000)[a]	Entities [b]	Average Receipts per Entity	Profit Rate [c]	Estimated Profits per Entity	Estimated Cost of the Final Rule	Average Cost per Entity	Ratio of Average Cost to Revenues	Ratio of Average Cost to Profits
8139	Business, Professional, Labor, Political, and Similar Organizations	\$29,068,582	56,541	\$514,115	2.05% *	\$10,534	\$773,516	\$13.68	0.003%	0.130%

[a] Estimated based on 2007 receipts and payroll data from U.S. Census Bureau, Statistics of U.S. Businesses, 2007, and payroll data from U.S. Census Bureau, Statistics of U.S. Businesses, 2007.

[b] U.S. Census Bureau, Statistics of U.S. Businesses, 2007.

[c] Estimated from average of the yearly ratios of net income to total receipts as reported by the U.S. Internal Revenue Service, Corporation Source Book, 2000–2008. Data were not available at disaggregated levels for all industries; profit rates at more highly aggregated levels are used for such industries.

N/A: Data not available.

*Profit rate imputed from corresponding 3-digit NAICS industry.

** Profit rate imputed from corresponding 2-digit NAICS industry.

Source: U.S. Department of Labor, OSHA, Directorate of Standards and Guidance, Office of Regulatory Analysis-Safety.

BILLING CODE 4510-29-C

OSHA's impact analysis for small entities indicates that one other

industry, NAICS 2213—Water, sewage and other systems, will experience

significant profit impacts under a worst-case scenario: Costs are 5.3 percent of profits for entities defined as small by the SBA, and costs are 11.7 percent of profits for entities with fewer than twenty employees. While profit impacts at these levels suggest that utilities in NAICS 2213 may have to reduce operations substantially if they are unable to pass forward to customers the approximately \$3,441 in annualized compliance costs, OSHA expects that most water and sewage employers will not experience profit impacts of that severity. First, whereas the estimate of revenue per small entity (fewer than 100 employees) in 2007 is approximately \$823,000 (Tables V-2 and V-32), according to 2012 Census data, revenue per small entity in NAICS 2213 rose to \$956,000. Assuming those higher per-entity revenues continued up until the scheduled compliance with this final standard, the impacts of costs on revenue and profit would be less severe than suggested using the 2007 receipts data.

Moreover, there is reason to think that OSHA's data understates actual profits for small utilities. Many small utilities are organized as cooperatives and a modest percentage of utilities file income tax returns as S Corporations, and the tax law allows both types of entities to pass profits back to members without being taxed as income at the business level. According to IRS data,¹⁶¹ of the 3,216 tax returns filed by utilities (NAICS 22) as S corporations in 2012, only 2,693 S-corporation utilities reported net income, suggesting that of the 5,973 firms in NAICS 22 in 2012, just under 9 percent ((3,216 S returns filed—2,693 S returns with net income)/5,973 total returns in NAICS 22) may have had profit that was not reported as income on the corporate return. However, they would have been included in the balance sheet data that formed the basis for the calculation of the average profit rate, 5.4 percent, for NAICS 2213. As evidence supporting this conclusion, IRS data indicate that for S utility corporations that reported net income, 2012 profit rates averaged 9.7 percent.¹⁶² Therefore, if the overall nine-year (2000–2008) average profit rate for NAICS 2213 underestimates the actual profit rate for the industry,

¹⁶¹ See <https://www.irs.gov/uac/soi-tax-stats-s-corporation-statistics>, Table 1: Returns of Active Corporations, Form 1120S and Table 2: Returns with Net Income, Form 1120S.

¹⁶² See <https://www.irs.gov/uac/soi-tax-stats-s-corporation-statistics>, Table 2: Returns with Net Income, Form 1120S. For Utilities in 2012, Total net income (less deficit) = \$689,965 thousand, or \$690.0 million, and Total Receipts = \$7,112,150 thousand, or \$7.1 billion. Profit rate = \$690 million/\$7.1 billion = 9.7 percent.

impacts resulting from compliance with this final standard may be overstated in Tables V-32 and V-33.

3. A Statement of the Need for, and Objectives of, the Rule

Employees in general industry performing construction, installation, maintenance, and repair tasks are exposed to a range of significant slip, trip, and fall hazards that cause serious injury and death. OSHA estimates that approximately 202,100 serious injuries and 345 fatalities occur annually among these employees. Although employers could prevent some of these incidents with increased compliance with existing safety standards, research and analyses conducted by OSHA found that many preventable injuries and fatalities would continue to occur even if employers achieved full compliance with the existing standards. Without counting incidents that employers could potentially prevent by complying fully with existing standards, OSHA estimates that full compliance with these final standards would prevent 5,842 additional injuries and 29 fatalities annually, even with full compliance with the existing standard.

As explained above, additional benefits associated with this rulemaking involve providing updated, clear, and consistent safety standards regarding fall protection in general industry to the relevant employers, employees, and interested members of the public. The existing OSHA standards for walking-working surfaces in general industry are over 30 years old and inconsistent with the more recently promulgated standards addressing fall protection in construction. OSHA believes that the final updated standards are easier to understand and to apply than the existing standard, thereby benefiting employers and employees by facilitating compliance and improving safety.

4. Response to Comments Filed by the Small Business Administration

The Small Business Administration's Chief Counsel for Advocacy (SBA Advocacy) submitted comments into the rulemaking record following publication of the NPRM. SBA Advocacy's comments (Ex. 124) covered four broad areas; OSHA addresses each area below.

Area 1: "OSHA should not include vague, overly-broad, 'general duty clause' type requirements."

OSHA's response: SBA Advocacy expressed concern that some provisions, such as proposed § 1910.22(a)(3) which required employers to "ensure that all surfaces are designed, constructed and maintained free of recognized hazards," lacked detail and precise definition, and

would, therefore, place an unreasonable compliance burden on employers. In the final standards, OSHA revised the proposed language of paragraph (a)(3) to provide specific examples of the types of hazards addressed by this provision—e.g., protruding or sharp objects, spills. The final regulatory text no longer requires that employers identify and correct all "recognized" hazards.

Area 2: "OSHA should further synchronize the proposed general industry rule with the existing construction standard."

OSHA's response: OSHA believes that, to the extent possible given the technological and work-organization differences between general industry and construction, the final standards mesh closely with the construction fall protection standards. Whenever possible, to avoid duplication, inconsistency, or overlap, the final standards reference the OSHA construction standards (for example, § 1910.27(a), Scaffolds; § 1910.28(b)(12), Scaffolds and rope descent systems; and § 1910.29(b), Guardrail systems reference part 1926).

Area 3: "OSHA should not expand its reading of Section 1910.22 to regulate combustible dust."

OSHA's response: As noted in this preamble and in the preamble to the NPRM, OSHA interprets the housekeeping provisions in subpart D as applying to combustible-dust accumulations associated with fire and explosion hazards. Regarding this interpretation, one court stated that "the housekeeping standard is not limited to tripping and falling hazards, but may be applied to [a] significant accumulation of combustible dust" (*Con Agra, Inc. v. Occupational Safety and Health Review Commission*, 672 F.2d 699, 702 (8th Cir. 1982), citing *Bunge Corp. v. Secretary of Labor*, 638 F.2d 831, 834 (5th Cir. 1981), which reached the same conclusion). Following publication of the NPRM, OSHA received no evidence that the regulated community had technological or economic concerns about including combustible dust in the scope of the housekeeping section of final subpart D. Therefore, OSHA will continue to regulate combustible-dust hazards on walking-working surfaces in this final standard.

Area 4: "OSHA should not regulate commercial motor vehicles (trucks) under the proposed rule."

OSHA's response: Based on comments and testimony received on both the 2003 Reopening Notice and the 2010 Proposed Rule, OSHA finds it is sometimes feasible to provide fall protection for rolling stock where it is not contiguous or next to a structure.

However, OSHA still believes that additional information and data analysis is needed in order to determine an appropriate course of action. Therefore, this Final Rule does not include any specific requirements for fall protection on rolling stock and motor vehicles and OSHA's current existing enforcement policies on rolling stock and motor vehicles will remain in effect. This issue is discussed further in the Summary and Explanation for final rule § 1910.21(a).

5. Issues Raised Regarding the Small Business Regulatory Enforcement Fairness Act

The U.S. Chamber of Commerce ("the Chamber") addressed the absence of a review process under the Small Business Regulatory Enforcement Fairness Act (5 U.S.C. 601 *et seq.*) (SBREFA) during this rulemaking, stating:

OSHA's decision to forgo SBREFA panel review for this rulemaking is even more troubling when one considers that the agency has undertaken SBREFA reviews with a number of rulemakings that have impacted a smaller number of workplaces and employees than this proposed walking-working surfaces revision will impact. . . . [T]his rulemaking will have a direct effect on a wide array of employers, both large and small, across all types of operations. This rulemaking is broader in application than many of the rulemakings noted above, with new requirements for training, and associated levels of personal protection. There are a large number of variables that will determine how these requirements will actually impact employers, especially small employers, and the agency would have benefited from the opportunity to obtain data and information from small employers. This is particularly true with respect to OSHA's effort to synchronize the general industry and construction industry provisions where small businesses are most likely to be confused and would have been able to provide useful input on achieving this goal. The scope of this regulation is so broad, and it will impose fall protection on so many workplaces for the first time, that OSHA should have conducted a panel to gather from affected entities direct information on how to better tailor this regulation. The Chamber urges OSHA to conduct a SBREFA panel review before proceeding to a final regulation. (Ex. 202, p. 2.)

In response to the concerns of the Chamber and the other stakeholders that expressed similar views (*i.e.*, the Sheet Metal and Air Conditioning Contractors National Association (Ex. 165) and the National Federation of Independent Business (Ex. 173)), OSHA notes that throughout the rulemaking process, during the public hearings and on other

occasions (including during the 2003 reopening of the record for a request for information), OSHA solicited and received comment from small firms on a variety of issues. Topics that involved input from small firms included, for example, safety on fixed ladders in outdoor advertising (Exs. 136; 229), the design of guardrails and gates at ladderway openings (Exs. 68; 366), use of rope descent systems for window cleaning (Exs. 69; 76), and protection of utility workers when ascending and descending stepbolts (Ex. 155). In developing and finalizing its final standards for subparts D and I, OSHA thoroughly considered the concerns expressed by small firms and other stakeholders representing the views of small firms, and revised requirements as appropriate.

6. Information Regarding the Small Entities Covered by the Final Rule

OSHA's analysis of the impacts of this final rule includes an analysis of the type and number of small entities impacted by the final rule. The final rule primarily impacts workers performing installation, maintenance, and repair tasks throughout general industry. To determine the number of small entities potentially affected by this rulemaking, OSHA used the definitions of small entities developed by the Small Business Administration for each industry. In section C of this FEA, OSHA discussed its methodology for determining the number of affected small entities, and presented its estimates of the number in Table V-2. As shown in that table, OSHA estimates that the final standards would cover 5.1 million small entities, employing 43.8 million workers, including 2.3 million workers directly exposed to slip, trip, and fall hazards. Industries (four-digit NAICSs) expected to have the highest number of affected at-risk employees include automotive repair and maintenance (390,000 employees), wired telecommunications carriers (170,000 employees), and lessors of real estate (84,000).

7. Administrative Costs for Employers

OSHA issued the existing standards in subpart D in 1971 under Section 6(a) of the Occupational Safety and Health Act of 1970 (the Act) (29 U.S.C. 655). During the period since OSHA issued existing subpart D, interested parties recommended revisions to its standards. In addition, the majority of the existing OSHA standards for walking-working

surfaces are inconsistent with numerous national consensus standards and the more recently issued OSHA standards addressing fall protection elsewhere in general industry (*e.g.*, § 1910.66, Powered platforms for building maintenance) and construction (*e.g.*, § 1926 Subpart M—Fall Protection).

Section F, Costs of Compliance, above described, for categories of employee training, the administrative costs for employers. Accordingly, OSHA does not consider the costs to document the training and retraining of employees to be recordkeeping, but rather typical expenses involved in administering a safety program.

8. Minimizing the Economic Impact on Small Entities

OSHA evaluated several alternatives to the final standards to ensure that the requirements would accomplish the stated objectives of applicable statutes and minimize the economic impact on small entities. For example, OSHA considered an alternative that would exempt small entities from the rule; however, the Agency rejected this alternative because it would unduly jeopardize the safety and health of affected employees. Throughout Section IV of this document, Summary and Explanation of the Final Rule, OSHA discusses other alternatives considered, generally in response to public comment.

In developing the final rule, especially establishing compliance or reporting requirements or timetables that affect small entities, OSHA took the resources available to small entities into account. OSHA clarified, consolidated, and simplified the compliance and reporting requirements applicable to small entities to the extent practicable. Wherever possible, OSHA allowed the employer multiple options to control fall hazards. Therefore, OSHA made every effort to provide maximum flexibility in the choice of controls required by the final rule.

To demonstrate the relative economic efficiency (*i.e.*, cost effectiveness) of the final subpart D standards, OSHA selected eight provisions from these standards for which it considered alternative controls, but rejected these controls as inefficient from a cost-effectiveness perspective. The table below presents OSHA's evaluation of the potential impacts associated with these alternative controls for the eight provisions.

BILLING CODE 4510-29-P

Table V-34
Impacts Associated with Regulatory Alternatives for Selected Provisions in Final Subpart D

Provision	Control(s) Specified by Provision	Alternative Control(s)	Potential Impacts of Alternative Control(s)
Section 1910.23, paragraph (a) Ladders	Covers all ladders except for machine-integrated or firefighting, rescue, and tactical law-enforcement ladders.	All ladders in scope.	Probably not significant in costs, but not justified with respect to benefits.
Section 1910.24, paragraphs (a)(1), (a)(7), and (b)(2) Step bolts and manhole steps	Design changes to step bolts and manhole steps on new installations performed on or after 60 days after the standard's effective date must meet specified strength and design criteria.	Eliminate grandfathering of older structures.	Requirement to ensure that <u>all</u> step bolts and manhole steps meet the strength and design criteria in revised subpart D would require technical resources that could exceed the capacity of affected industries in the near term given the need to inspect all existing manholes and make changes to many of them; benefits would not justify the large costs.
Section 1910.25, paragraph (b)(8) Stairways	When employees use ship stairs and spiral stairs as the primary means of egress, the stairs must meet the requirements specified by the standard.	Prohibit ship stairs and spiral stairs in all new installations.	Potentially large costs with few benefits.
Section 1910.26(b) Dockboards	This provision requires that dockboards put into service at least 60 days after the effective date of the final rule be designed, constructed, and maintained to prevent transfer vehicles (such as hand trucks) from running off the edge. An exception allows the employer to use dockboards that do not have run-off protection when the employer can demonstrate that there is no hazard of the equipment running off the edge.	Specify the means of achieving the desired performance (specific dockboard design requirements).	Probably modest costs but with few benefits.

**Table V-34
Impacts Associated with Regulatory Alternatives for Selected Provisions in Final Subpart D (continued)**

Provision	Control(s) Specified by Provision	Alternative Control(s)	Potential Impacts of Alternative Control(s)
<p align="center">Section 1910.27(b)(2)(i) Use of rope descent systems</p>	<p align="center">Paragraph (b)(2)(i) prohibits the use of a rope descent system (RDS) at heights greater than 300 feet (91.4 m) above grade unless the employer demonstrates that it is not feasible to access such heights by any other means or that those means pose a greater hazard than using a rope descent system.</p>	<p align="center">Allow use of RDS at all heights.</p>	<p>As OSHA demonstrated earlier in this FEA, impacts of the primary choice will be manageable due to the current availability of (1) powered platforms, swing-stage equipment, or other systems for washing windows on tall buildings, and (2) the managerial and technical expertise for combining RDS and other types of equipment. The impact of the alternative control would be heightened risk of exposure to unexpected wind gusts and other factors that could jeopardize safe control of the RDS for descents greater than 300 feet.</p>
<p align="center">Section 1910.28 Duty to have fall protection and falling-object protection</p>	<p>The final rule allows employers to choose from several options in providing fall protection across generic walking-working surfaces. These include conventional fall protection systems such as guardrail systems, safety-net systems, and personal fall protection systems (restraint systems, personal fall arrest systems, and positioning systems) and, in some instances, non-conventional means. An example of non-conventional means would be establishing a designated area in which an employee is to work.</p>	<p>Provided detailed specifications, on a surface by surface basis, the means of achieving compliance.</p>	<p>Depending on specifications, costs could be substantial with modest benefits.</p>

**Table V-34
Impacts Associated with Regulatory Alternatives for Selected Provisions in Final Subpart D (continued)**

Provision	Control(s) Specified by Provision	Alternative Control(s)	Potential Impacts of Alternative Control(s)
<p>Section 1910.28(b)(8) Repair pits, service pits, and assembly pits less than 10 feet in depth</p>	<p>This provision requires employers to limit access to the edge (within 6 feet (1.8 m)) of the pit to trained, authorized employees ((b)(8)(i)); mark the floor or place warning lines and stanchions to designate the unprotected area ((b)(8)(ii)); and post caution signs to warn employees of the unprotected area ((b)(8)(iii)).</p>	<p>Require conventional fall protection systems such as guardrails, or personal fall arrest or travel restraint systems.</p>	<p>Potentially significant costs with feasibility/practicability concerns.</p>
<p>Section 1910.28(b)(9) Fixed ladders (that extend more than 24 feet (7.3 m) above a lower level)</p>	<p>This provision requires no fall protection for employees exposed to falls from fixed ladders of 24 feet (7.3 m) in length or less above a lower level. If the employer uses an existing cage or well, each section must be offset from adjacent sections with landing platforms at maximum intervals of 50 feet (15.2 m). If an employer uses a ladder safety system or personal fall arrest system, there must be rest platforms at maximum intervals of 150 feet (45.7 m).</p>	<p>For fixed ladders, require employers to provide cages, wells, landing platforms, and ladder safety systems comprehensively.</p>	<p>Major costs and modest benefits; tens of thousands of fixed ladders would need cages, wells, and landing platforms.</p>

Source: U.S. Department of Labor, OSHA, Directorate of Standards and Guidance, Office of Regulatory Analysis-Safety.

OSHA also considered non-regulatory alternatives in determining the appropriate approach to reducing occupational hazards associated with work on elevated or slippery surfaces in general industry. The Agency discusses these alternatives in Section B of this FEA.

I. Sensitivity Analyses

1. Introduction

In this subsection, OSHA presents the results of two different types of sensitivity analysis to demonstrate how robust the estimates of net benefits are to changes in selected cost and benefit parameters. In the first sensitivity analysis (the “standard sensitivity analysis”), OSHA makes a series of isolated changes to individual cost and benefit parameters to determine their effects on the Agency’s estimates of annualized costs, benefits, and net benefits. In the second sensitivity analysis—the “break-even sensitivity analysis”—OSHA investigates isolated changes to individual cost and benefit parameters, but with the objective of determining the magnitude of the changes needed for annualized costs to equal annualized benefits. The Agency is conducting these analyses for informational purposes only.

2. Sensitivity Analysis for Specific Parameters

OSHA provides below a sensitivity analysis of some assumptions underlying the Agency’s estimates of the annualized costs and benefits of the final rule. The calculations underlying the Agency’s estimate that the compliance costs, benefits, and economic impacts associated with this rulemaking are generally linear and additive. Accordingly, the changes in the costs or benefits should generally be proportional to variations in the relevant input parameters. For example, if the estimated time for supervisors to inspect the conditions of walking-working surfaces (to ensure that they are free of hazards) increased by 100 percent, the corresponding labor costs for that task also should increase by 100 percent.

OSHA evaluated a series of such changes in input parameters to test the validity of the general conclusions derived from the economic analysis. Overall, OSHA found these conclusions to be robust as even sizeable changes in the values of several input parameters did not substantially alter the estimates of the costs, benefits, or net benefits. Furthermore, the rule produces significant positive net benefits regardless of the revisions made to

costs, benefits, or the discount rate. Table V–35 below provides the summary results of these sensitivity tests. In each sensitivity test, parameters other than the ones tested remained unchanged.

In the first sensitivity test, OSHA adjusted the estimated noncompliance rates applied to the costs for the requirements for inspections and hazard corrections in final § 1910.22(d). When OSHA doubles the noncompliance rates (deriving noncompliance rates that range from 6 percent to 27 percent), annualized costs rise by \$33.2 million (10.9 percent), with total compliance costs summing to \$338.2 million, and net benefits are reduced by an equal amount (\$33.32 million), to a level of \$276.4 million. In the benefits sensitivity analysis, OSHA also considered the effect of changing these provisions on benefits.

In the second sensitivity test on costs, when OSHA increased by 100 percent the estimated time for supervisors to inspect walking-working surfaces for the presence of hazards (from one hour to two hours), the estimated total costs of compliance increased by \$33 million annually, or about 11 percent of overall costs. In the third sensitivity test on costs, OSHA increased a set of values for variables critical to the estimated compliance costs for fall protection on fixed ladders as follows:

- Increased the estimate of the number of fixed ladders per establishment by 100 percent (0.45 to 0.9); and
- Increased the installation time for ladder safety systems by 100 percent (two hours to four hours).

This sensitivity test increased the estimated annualized compliance costs by \$0.4 million annually, about 0.1 percent of overall costs.

In the fourth sensitivity test on costs, OSHA extended from 20 years to 25 years after publication of the rule the date when OSHA would no longer accept cages and wells for fall protection, thereby requiring employers to install other forms of fall protection such as ladder safety systems on fixed ladders that extend more than 24 feet above a lower level. This sensitivity test decreased the estimated annualized compliance costs by \$1.0 million annually, or about 0.3 percent of overall costs.

In the fifth sensitivity test on costs, OSHA retrofitted all fixed ladders over 20 feet in length with ladder safety systems (not just those ladders that extend more than 24 feet above a lower level) according to a 20-year deadline specified by final § 1910.28(b)(9)(i)(D), with the result that costs increased by

\$10.1 million annually, or 3.3 percent of overall costs.

OSHA believes this stringent test represents a highly unlikely scenario because the current consensus standard for fixed ladders—ANSI A14.3–2008, American National Standard for Ladders—Fixed—Safety Requirements—requires use of a ladder safety system only for single climbs in excess of 24 feet, whereas the 2002 version of that standard prescribed the use of ladder safety systems for climbs in excess of 50 feet. Furthermore, current § 1910.27(d)(5) permits the use of ladder safety devices instead of cages on tower, water-tank, and chimney ladders over 20 feet in unbroken length. In addition, evidence in the record suggests that firms with a choice of a cage/platform or ladder safety systems generally install ladder safety systems for ladders reaching heights above 30 feet, and that safety engineers are now designing solutions using ladder safety systems for fall protection during all long ladder climbs (Exs. 127; 369). Therefore, OSHA believes that only a small percentage of fixed ladders, *i.e.*, ladders between 24 and 30 feet in height, would require retrofitting with ladder safety systems 20 years after publication of the final rule.

In a sixth sensitivity test on costs, OSHA increased by 100 percent the estimated time for employee training, which increased the estimated costs of compliance by \$54.1 million annually, or about 18 percent of overall costs.

Finally, in a seventh sensitivity test on costs, OSHA increased by 100 percent the estimated time for a supervisor to conduct a hazard assessment needed before issuing personal fall protection equipment. This sensitivity test increased the estimated costs of compliance by \$11.6 million annually, or roughly 4 percent of overall costs.

In addition, OSHA examined the effect on annualized costs and benefits of changing the discount rate. Changing the discount rate from seven percent, used in the base case, to three percent would reduce the estimated costs of the final rule from \$305.0 million to \$297.0 million per year (while leaving estimated annual benefits unaffected), thereby increasing the estimated net benefits by \$7.9 million. For both this scenario and for the primary (seven-percent rate) scenario, with the exception of the 20-year deadline for installation of specific types of fall protection on certain fixed ladders, OSHA assumed that employers would incur all costs (first-year and recurring) upon implementation of the final standards (*i.e.*, no phase-in provisions).

OSHA also assumed that the benefits outlined in this section will begin accruing once the rule takes effect.

OSHA recognizes that there is not one uniform approach to estimating the marginal cost of labor. For the economic analysis in support of the final rule, OSHA has estimated the marginal costs of labor as wages plus a fringe benefit rate of 41.5% (which includes some fixed costs such as health insurance). However, this approach does not account for overhead costs. For illustrative purposes in the context of this sensitivity analysis, OSHA has modified the cost estimates by including an overhead rate when estimating the marginal cost of labor. It is important to note that there is not one broadly accepted overhead rate in academic literature and estimating the most appropriate overhead rate for this FEA would require significant modeling, including as regards the interaction between overhead costs and the equipment and other costs that have been separately estimated. Further, the Department has not further analyzed an appropriate quantitative adjustment.

Therefore, DOL adopted for the purposes of this specific exercise an overhead rate of 17%. This rate has been used by the EPA in its final rules (see for example, EPA Electronic Reporting under the Toxic Substances Control Act Final Rule, June 17, 2013), and is based upon a Chemical Manufacturers Association study.¹⁶³

Using an overhead rate of 17% would increase costs by \$24.4 million per year, or 8.0 percent above the best estimate of costs. (See Table V-35)

OSHA also performed sensitivity tests on a set of input parameters used to estimate the benefits of the final rule. In the first test, OSHA estimated that the

¹⁶³ The uncertainty surrounding the appropriate amount of overhead cost to include in loaded wages may be observed in the range of estimates that other Agencies have included for overhead rates specific to their requirement. For example, recent regulatory impact analyses conducted by agencies of the Department of Health and Human Services (HHS) have featured doubling of base wages to account for both fringe benefits and overhead. DOL's Employee Benefits Security Administration (EBSA) includes overhead costs that are substantially higher than EPA's and more variable across employee types than HHS's, as presented in detail at www.dol.gov/ebsa/pdf/labor-cost-inputs-used-in-ebsa-opr-ria-and-pra-burden-calculations-march-2016.pdf.

final preventability rates for falls from ladders (20 percent), falls from roofs (20 percent), and falls to lower levels not elsewhere classified (5 percent) did not increase from the estimates applied in the PEA, but instead remained the same for this FEA (*i.e.*, 15 percent, 15 percent, and 2.5 percent, respectively). As a result of using the (lower) preliminary preventability rates, the estimated monetized benefits fell by \$89.6 million annually relative to final monetized benefits, or about 15 percent of overall benefits.

In a second benefits sensitivity test, OSHA reduced the preventability rate for falls on the same level from 1 percent to 0 percent. As a result, monetized benefits fell 13.8 percent (\$85.0 million) to \$530.0 million, and net benefits fell to \$225.0 million.

In a third benefits sensitivity test, OSHA doubled the preventability rate for falls on the same level from 1 percent to 2 percent. As a result, monetized benefits rose 13.8 percent (\$85.0 million) to \$699.6 million, and net benefits rose to \$394.6 million.

BILLING CODE 4510-29-P

Table V-35
Sensitivity Tests for the Economic Analysis of the Final Standards on Walking-Working Surfaces

Cost Parameters						
Variable	OSHA's Current Estimate	New Parameter Value	Change in Annualized Costs (million)	Percentage Change in Annualized Costs	Annualized Costs (million)	Net Benefit (million)
OSHA's Best Estimate of Total Annualized Costs:					\$305.0	\$310.0
Floor Guarding Non-Compliance Rate (applied in inspection costs)	Non-compliance rate doubles	6% to 27%	\$33.2	10.9%	\$338.2	\$276.4
Supervisor time to inspect walking-working surfaces for hazards	Average of 30 minutes per establishment per quarter (2 hours per year)	4 hours	\$32.8	10.8%	\$337.8	\$287.2
Number of fixed Ladders per establishment; time to install ladder safety system; percent of fixed ladders added or replaced each year	Number of fixed ladders per establishment: 0.45	0.9 ladders	\$0.4	0.1%	\$305.3	\$319.6
	Time to install ladder safety system: 2 hours	4 hours				
	Grace period for retrofitting fixed ladders with safety devices: 20 years	25 years	-\$1.0	-0.3%	\$304.0	\$320.9
	Retrofitting all ladders longer than 20 feet instead of ladders between 24 and 30 feet	3,059,106 ladders	\$10.1	3.3%	\$315.1	\$309.9

Table V-35 (continued)
Sensitivity Tests for the Economic Analysis of the Final Standards on Walking-Working Surfaces

Cost Parameters						
Variable	OSHA's Current Estimate	New Parameter Value	Change in Annualized Costs (million)	Percentage Change in Annualized Costs	Annualized Costs (million)	Net Benefit (million)
OSHA's Best Estimate of Total Annualized Costs:					\$305.0	\$310.0
Employee training	Employee time for initial and annual training: 6 hours and 1 hour (4 hours for some NAICS industries) for, respectively, training on fall hazards and equipment hazards	12 hours	\$54.1	17.7%	\$359.1	\$265.9
		2 hours				
		8 hours				
	Supervisor administrative time per employee: 0.25 hours	0.5 hours				
Supervisor time to conduct hazard assessment needed to issue personal fall protection equipment	Establishments with:		\$11.6	3.8%	\$316.6	\$308.4
	1-19 employees – 1 hour	2 hours				
	20-99 employees – 2 hours	4 hours				
	100-499 employees – 3 hours	6 hours				
	500+ employees – 4 hours	8 hours				
Discount rate	7 percent	3%	-\$8.0	-2.6%	\$297.0	\$327.9
17% Overhead Rate Included	Base wage rate calculated with 17% overhead included	17%	\$24.4	8.0%	\$329.4	\$295.6

Table V-35 (continued)
 Sensitivity Tests for the Economic Analysis of the Final Standards on Walking-Working Surfaces

Benefit Parameters						
Variable	OSHA's Best Estimate	New Parameter Value	Change in Annualized Benefits (million)	Percentage Change in Annualized Benefits	Annualized Benefits (million)	Net Benefit (million)
OSHA's Best Estimate of Total Annualized Benefits:					\$615.0	\$310.0
Preventability rates for falls from ladders, roofs, or lower levels not elsewhere classified	Ladders – 20%	15%	-\$89.6	-14.6%	\$525.0	\$220.0
	Roofs – 20%	15%				
	Lower Levels, N.E.C. – 5%	2.5%				
Preventability Rate for Falls on Same Level	Percentage falls prevented reduced to 0%	0%	-\$85.0	-13.8%	\$529.6	\$224.6
	Percentage falls prevented doubles to 2%	2%	\$85.0	13.8%	\$699.6	\$394.6

Source: U.S. Department of Labor, OSHA, Directorate of Standards and Guidance, Office of Regulatory Analysis-Safety.

OSHA's benefits estimates are most sensitive when it comes to estimating the percentage of current injuries and fatalities avoided by full compliance with the final standards. OSHA closely examined available reports of fatalities related to the provisions in the existing and final standards and found that full compliance with the final standards would prevent 29 fatalities, or approximately 9 percent of all slip-, trip-, and fall-related fatalities in general industry (including, among the global group, accidents not directly addressed by the final standards). The true benefits of the final rule depend on how well these fatalities represent actual fall-related fatalities in general industry that compliance with the final rule would prevent. OSHA believes that the benefits in this FEA (see Table V-11) are representative of actual prevented fatalities; however, an average estimate such as presented here can mask year-to-year variations.

The Agency believes that its estimate of annual fatalities involving slips, trips, and falls (about 345) in general industry is a much less sensitive estimate of actual fatalities than the estimate of the percentage of fatalities avoided. The estimate of the annual number of baseline fatalities is derived from 7 years of recent accident data with percent-distributed averages corroborated by 11 prior years of data, whereas the estimate of percentage of fatalities avoided is based on professional judgment (the determinations from which were placed into the record and reviewed by rulemaking stakeholders). Furthermore, as noted earlier, OSHA believes that its benefits estimates are low. Specifically, the Agency believes the training and work-practices requirements specified by the final standards would likely improve the use and application of safety equipment (including personal fall protection equipment), thereby further reducing fatalities and injuries.

In conclusion, these sensitivity tests demonstrate that even with relatively large variations in the input parameters, there are no large changes in the estimates of compliance costs or benefits.

3. Sensitivity Analysis With Respect to Noncompliance and Possible Overestimation of Benefits

In the benefits section, OSHA noted that an article by Seong and Mendeloff suggested that OSHA had, in a period of 17 to 27 years ago, estimated reductions in fatalities that were not in fact reflected in the observed data over the next ten years. All of the analyses in question assumed full compliance with

the rule, as does this analysis. The resulting failures to meet observed declines could have been the result of either failure to comply with OSHA's rule, or overestimates of the effectiveness of OSHA's rule. OSHA believes that it was a combination of the two—there were both overestimates of effectiveness and failures to comply with the rule. Unfortunately, there are no studies that enable us to distinguish between the two phenomena. Further, OSHA believes that its estimates for this rule reflect lessons learned from the Seong and Mendeloff article. Still OSHA believes it is important to analyze the possibilities that the article might reflect OSHA's current practice and that it might reflect the possibility that OSHA's overestimates are solely due to noncompliance with the rule.

In Appendix A, OSHA derives a set of factors for reducing OSHA's benefits estimates based on the assumption that Seong and Mendeloff's observations correctly state the standard's effectiveness rates. These factors represent a possible correction to OSHA's base estimates. The exact possible correction factors and their limitations are given in Appendix A to this FEA.

Using these correction factors, OSHA found that the standard would prevent from 9 fatalities and 1,753 non-fatal injuries ($=0.3 \times 29$ and $0.3 \times 5,842$), with a value of \$184 million, to 14 fatalities and 2,746 non-fatal injuries ($=0.47 \times 29$ and $0.47 \times 5,842$), with a value of \$289 million. If application of these correction factors to OSHA's estimation methodology better represent the true benefits of the rule, then this lower range of benefits would be more compliant with OMB Circular A-4, than the 29 fatalities and 5,842 non-fatal injuries presented at the summary results elsewhere in this FEA.

If lack of employer compliance is the only driver of the disparities between OSHA's estimates and actual declines in fatalities and if non-compliance is close to homogeneous across employers covered by this rule (in other words, if baseline slip, trip and fall injuries are not largely concentrated amongst bad actors who do not attempt to comply with OSHA standards), then the appropriate cost estimates to compare to the above benefits estimate would be \$91 million ($=0.3 \times \305 million) to \$143 million ($=0.47 \times \305 million), and net benefits remain positive.

To the extent that OSHA has not corrected any overestimation of effectiveness that is not the result of noncompliance, then costs could exceed benefits. As noted, OSHA is aware of the possible overestimation for reasons

other than less than full compliance and has tried to correct this overestimation.

4. Break-Even Sensitivity Analysis

This break-even sensitivity analysis determines how much cost and benefits would have to vary for the costs to equal benefits. According to the Agency's models for estimating costs and monetized benefits, the final standards generate considerable positive net benefits; that is, expected benefits are much greater than expected costs. Only significant errors in OSHA's analysis would bring true net benefits to, or below, zero. Therefore, in the first break-even sensitivity test in this analysis, which addresses cost, for net monetized benefits to fall to zero, for example, the Agency would have to underestimate the number of buildings with anchorages subject to inspection and certification by two-fold (from about 750,000 buildings to 1.5 million buildings), and would also have to underestimate the number of employees requiring training by four-fold (from 504,000 to 2.0 million). In this case, estimated compliance costs would rise to roughly \$593 million annually, thereby approaching the value of estimated monetized benefits and reducing the net monetized benefits approximately to zero.

In a second break-even sensitivity test in this analysis, which addresses benefits, OSHA examined how much its estimate of the final rule's aggregate benefits in terms of avoided fatalities and injuries would have to decline for the costs to equal the benefits, thereby eliminating the net monetized benefits. Net monetized benefits would decline to zero if, for example, the Agency overestimated fatalities prevented by the final standards by roughly 93 percent (if prevented fatalities were 15 rather than 29) and overestimated injuries prevented by the standards by roughly 108 percent (if prevented injuries were 2,814 rather than 5,842).

OSHA believes that a ten percent overestimate of fatalities is unlikely given the conservative (low) accident preventability rates projected for many provisions of the final standards. Further, OSHA notes, as discussed earlier, that some of the other benefits of the rule are non-quantifiable, such as the benefits resulting from making several provisions in this final standard compatible with provisions in the Agency's construction fall protection standards. OSHA believes that these benefits would increase the overall net benefits of the final rule.

J. References

- American National Standard Institute-International Window Cleaning Association (ANSI-IWCA, 2001). Window Cleaning Safety. IWCA I-14.1-2001, October 2001.
- Amodeo, Linda (Amodeo, 2003). Comments submitted to OSHA Docket S029. Linda Amodeo, Vice President, City Wide Building Services, Inc., July 24, 2003. Ex. OSHA-S029-2006-0662-0074.
- Ashford, N.A., 2006. "Workers' Compensation," in *Environmental and Occupational Medicine, Fourth Edition*, W.N. Rom & S. Markowitz (Eds.), Lippincott-Raven Publishers, Philadelphia, pp. 1712-1719.
- Ashford, N.A., C. Ayers, and R.F. Stone, 1985. Using Regulation to Change the Market for Innovation. *Harvard Environmental Law Review* 9(2): 871-906.
- Bureau of Labor Statistics (BLS, 2012). *Survey of Occupational Injuries and Illnesses in Cooperation with Participating State Agencies*. U.S. Department of Labor, March 2012.
- Bureau of Labor Statistics (BLS, 2011). *Employer Costs for Employee Compensation—June 2011*. <http://www.bls.gov/news.release/ecec.htm>. Accessed September 8, 2011.
- Bureau of Labor Statistics (BLS, 2009). *Occupational Employment Statistics, 2009*. <http://www.bls.gov/oes/home.htm>.
- Bureau of Labor Statistics (BLS, 2007) Job Openings and Labor Turnover Survey (JOLTS). <http://data.bls.gov/pdq/querytool.jsp?survey=jt>. Accessed June 7, 2016.
- Bureau of Labor Statistics (BLS, 2007). *Consumer Price Index, All Urban Consumers, U.S. City Average*, June 15, 2007. <ftp://ftp.bls.gov/pub/special.requests/cpi/cpiat.txt>.
- California Department of Industrial Relations (CA-DIR, 2012). California Code of Regulations, Title 8, Section 3286, "Manual Boatswain's Chairs and Controlled Descent Apparatus." California Labor Code Section 142.3. Accessed March 20, 2012.
- Cohen, Alexander and Michael Colligan (Cohen and Colligan, 1998). *Assessing Occupational Safety and Health Training: A Literature Review*. DDHS (NIOSH) Publication 98-145, June 1998. Docket OSHA-2007-0072 (Ex. OSHA-2007-0072-0047).
- Council on Tall Buildings and Urban Habitat (CTBUH, 2012). <http://www.ctbuh.org/>. *The Skyscraper Center; The Global Tall Building Database of the CTBUH*. <http://www.skyscrapercenter.com/index.php>.
- Council on Tall Buildings and Urban Habitat (CTBUH, 2006). Web Site: <http://www.ctbuh.org/>. Database hosted by Emporis. <http://buildings.emporis.com/?nav=theplatformconcept&lng=3>.
- Department of Energy (DOE, 2013). *2009 Residential Energy Consumption Surveys. Housing Characteristics Tables. Table HC2.1: "Structural and Geographic Characteristics of U.S. Homes, By Housing Unit Type, 2009."* Energy Information Administration, 2013. <http://www.eia.gov/consumption/residential/data/2009/index.cfm?view=characteristics>.
- Department of Energy (DOE, 2006). *2003 Commercial Buildings Energy Consumption Survey. Table B10: "Number of Floors, Number of Buildings and Floorspace for Non-Mall Commercial Buildings."* Energy Information Administration, 2006. http://www.eia.doe.gov/emeu/cbecs/cbecs2003/detailed_tables_2003/detailed_tables_2003.html.
- Department of Energy (DOE, 2004). *2001 Residential Energy Consumption Surveys. 2001 Housing Characteristics Tables. Table HC1-1a: "Housing Unit Characteristics by Climate Zone, Million U.S. Households, (2001)."* Energy Information Administration, 2004. http://www.eia.doe.gov/emeu/recs/recs2001/detail_tables.html.
- DiChacho, Rosita (DiChacho, 2006). Personal communication between Rosita DiChacho, New York Department of Labor, Division of Safety & Health, Engineering Services Unit and Maureen F. Kaplan, Eastern Research Group, August 23, 2006.
- Eastern Research Group, Inc. (ERG, 2007). *Technical and Analytical Support and Docket Review for OSHA's Preliminary Analysis of Costs, Benefits, and Economic Impacts for OSHA's Proposed Standard for Walking and Working Surfaces*. Final Report. Prepared under Contract No. GS10F0125P for the U.S. Department of Labor, Occupational Safety and Health Administration, Directorate of Evaluation and Analysis, Office of Regulatory Analysis, July 27, 2007. Docket OSHA-2007-0072 (Ex. OSHA-2007-0072-0046).
- Eastern Research Group, Inc. (ERG, 1999). *PPE Cost Survey: Final Report*. Prepared under Contract No. J-9-F-9-0010 for the U.S. Department of Labor, Occupational Safety and Health Administration, Office of Regulatory Analysis, June 23, 1999. Docket OSHA-S042-2006-0667 (Ex. OSHA-S042-2006-0667-0318).
- Federal Motor Carrier Safety Administration (FMCSA, 2010). "Safety Requirements for Operators of Small Passenger-Carrying Commercial Motor Vehicles Used in Interstate Commerce; Final Rule." **Federal Register** 75: 4996. <http://www.fmcsa.dot.gov/rules-regulations/administration/rulemakings/final/Safety-Requirements-Small%20Passenger-Carrying-CMV-in-Interstate.pdf>. Accessed May 29, 2013.
- Institute of Electrical and Electronics Engineers (IEEE, 2006). *IEEE Standard for Fall Protection for Utility Work*. IEEE Standard 1307-2004. <http://standards.ieee.org/reading/ieee/std/numerical.html>. Accessed by ERG on July 24, 2006.
- International Window Cleaning Association (IWCA, 2014). "The High Cost of Non Compliance with the ANSI/IWCA I-14 Window Cleaning Safety Standard" and "IWCA Resources for Building Owners & Property Managers." <http://www.iwca.org/>.
- Kreidenweis, Andy (Kreidenweis, 2003). Comments submitted to OSHA Docket S-029. Andy Kreidenweis, Braco Window Cleaning Service Inc., July 30, 2003. Docket OSHA-S029-2006-0662 (Ex. OSHA-S029-2006-0662-0186).
- Lebel, Marc (Lebel, 2003). Comments submitted to OSHA Docket S-029. Marc Lebel, President, Pro-Bel Enterprises Limited, July 18, 2003. Docket OSHA-S029-2006-0662 (Ex. OSHA-S029-2006-0662-0069).
- Leigh, J.P., and J.P. Marcin, 2012. "Workers' Compensation Benefits and Shifting Costs for Occupational Injury and Illness," *Journal of Occupational and Environmental Medicine*, April, 54(4): 445-50.
- Lebel, Marc (Lebel, 2003). Comments submitted to OSHA Docket S-029. Marc Lebel, President, Pro-Bel Enterprises Limited, July 18, 2003. Docket OSHA-S029-2006-0662 (Ex. OSHA-S029-2006-0662-0069).
- Minnesota Office of the Revisor of Statutes (Minnesota, 2012). Minnesota Rule 5205.0730, "Window Cleaning; Building Maintenance." 2011 Minnesota Statutes, 182.655, "Occupational Safety and Health Standards." <https://www.revisor.mn.gov/rules/?id=5205.0730>. Accessed on March 30, 2012.
- National Academy of Social Insurance (NASI, 2012). "Workers' Compensation: Benefits, Coverage, and Costs, 2010," August. Available at <http://www.nasi.org/research/2012/report-workers-compensation-benefits-coverage-costs-2010>.
- National Association of Tower Erectors (NATE, 2006). Web site: <http://www.natehome.com/MemberBenefitsServices/NATECLIMBERTRAININGSTANDARD/Index.cfm>.
- National Coalition Against the Misuses of Pesticides (NCAMP, 1997). "Poison Poles—A Report About Their Toxic Trail and Safer Alternatives." *Estimate of Pole Miles and Distribution Poles by State, 1997*. <http://www.beyondpesticides.org/wood/pubs/poisonpoles/>.
- National Cooperative Highway Research Program (NCHRP, 2004). *NCHRP Report 500: Guidance for Implementation of the AASHTO Strategic Highway Safety Plan*. Volume 8: "A Guide for Reducing Collisions Involving Utility Poles." Transportation Research Board, 2004. http://safety.transportation.org/htmlguides/utl_pole/exec_sum.htm.
- National Council on Compensation Insurance (NCCI, 2013). "ABCs of Experience Rating." Available at <https://www.ncci.com/NCCIMain/Education/ExperienceRating/Pages/default.aspx>.
- National Fire Protection Association (NFPA, 2006). *Standard 101. Life Safety Code, 2006 Edition*. Section 7.2.2.2.3, "Spiral stairs." http://www.nfpa.org/freecodes/free_access_document.asp.
- National Institute for Occupational Safety and Health (NIOSH, 2004). *Worker Health Chartbook, 2004*. U.S. Department of Health and Human

- Services, Centers for Disease Control and Prevention, NIOSH, September 2004. <http://www.cdc.gov/niosh/docs/2004-146/pdfs/2004-146.pdf>. Accessed May 29, 2013.
- Neuhauser, F.W., S.S. Seabury, and J. Mendeloff, 2013. "The Impact of Experience Rating on Small Employers: Would Lowering the Threshold for Experience Rating Improve Safety?" *Rand Working Papers WR-955*. http://www.rand.org/pubs/working_papers/WR955.html.
- National Institute for Occupational Safety and Health (NIOSH, 1988). U.S. Department of Health and Human Services, Centers for Disease Control, National Institute for Occupational Safety and Health. *National Occupational Exposure Survey*. Volume III: "Analysis of Management Interview Responses," March 1988.
- Occupational Safety and Health Administration (OSHA, 2012a). Accident Investigation Search, 2012. <http://www.osha.gov/pls/imis/accidentsearch.html>.
- Occupational Safety and Health Administration (OSHA, 2012b). OSHA, Directorate of Training and Education. Resource Center Loan Program. Training Materials by Subject. http://www.osha.gov/dte/resource_center/catalog.html.
- Occupational Safety and Health Administration (OSHA, 2010). "Walking-Working Surfaces and Personal Protective Equipment (Fall Protection Systems)"; Proposed Rule. **Federal Register** 75: 28862-29153. May 24, 2010. Docket OSHA-2007-0072 (Ex. OSHA-2007-0072-0001).
- Occupational Safety and Health Administration (OSHA, 2009). Analysis of OSHA Integrated Management Information System Inspection Data, 1995-2001. January 2009. Docket OSHA-2007-0072 (Ex. OSHA-2007-0072-0049).
- Occupational Safety and Health Administration (OSHA, 2006a). Accident Investigation Search, 2006. <http://www.osha.gov/pls/imis/accidentsearch.html>.
- Occupational Safety and Health Administration (OSHA, 2006b). Standard Interpretations: 2/10/2006—"The use of ship's stairs instead of fixed stairs in general industry." http://www.osha.gov/pls/oshaweb/owadisp.show_document?p_table=INTERPRETATIONS&p_id=25301.
- Occupational Safety and Health Administration (OSHA, 2006c). Standard Interpretations: 2/10/2006—"Circumstances under which installation of fixed industrial stairs with a slope between 50 degrees and 70 degrees from the horizontal would be considered a de minimis violation." http://www.osha.gov/pls/oshaweb/owadisp.show_document?p_table=INTERPRETATIONS&p_id=25299.
- Occupational Safety and Health Administration (OSHA, 2003a). Standard Interpretations: 05/05/2003—"Standards applicable to step bolts and manhole steps; load requirements for step bolts." http://www.osha.gov/pls/oshaweb/owadisp.show_document?p_table=INTERPRETATIONS&p_id=24564 corrected 4/4/2005.
- Occupational Safety and Health Administration (OSHA, 2003b). "Walking and Working Surfaces; Personal Protective Equipment (Fall Protection Systems)"; Proposed Rule. **Federal Register** 68: 23528-23568, May 2, 2003.
- Occupational Safety and Health Administration (OSHA, 1996). "Safety Standards for Scaffolds Used in the Construction Industry"; Final Rule. **Federal Register** 61: 46026-46126, August 30, 1996.
- Occupational Safety and Health Administration (OSHA, 1994). "Background Document to the Regulatory Impact and Regulatory Flexibility Assessment for the PPE Standard." Office of Regulatory Analysis, March 15, 1994. Docket OSHA-S060-2006-0681 (Ex. OSHA-S060-2006-0681-0333).
- Occupational Safety and Health Administration (OSHA, 1993). "Fixed Ladders Used on Outdoor Advertising Structures/Billboards in the Outdoor Advertising Industry." OSHA Instruction STD 1-1.14, January 26, 1993. http://www.osha.gov/pls/oshaweb/owadisp.show_document?p_table=DIRECTIVES&p_id=1756.
- Occupational Safety and Health Administration (OSHA, 1991a). December 5, 1989, letter from Mr. Thomas J. Shepich to Mr. Carl Pedersen regarding Descent Control Devices. Memorandum to Regional Administrators from Patricia K. Clark, Director, Directorate of Compliance Programs, March 12, 1991. Docket OSHA-S029-2006-0662 (Ex. OSHA-S029-2006-0662-0019).
- Occupational Safety and Health Administration (OSHA, 1991b). "Grant of Variance." **Federal Register** 56: 8801, March 1, 1991. http://www.osha.gov/pls/oshaweb/owadisp.show_document?p_table=FEDERAL_REGISTER&p_id=13148. Accessed by ERG on August 26, 2006.
- Occupational Safety and Health Administration (OSHA, 1990a). "Preliminary Regulatory Impact and Regulatory Flexibility Analysis of Proposed Subparts D and I of 29 CFR Part 1910 Walking and Working Surfaces." Occupational Safety and Health Administration, Office of Regulatory Analysis, March 6, 1990. Docket OSHA-S041-2006-0666 (Ex. OSHA-S041-2006-0666-0689).
- Occupational Safety and Health Administration (OSHA, 1990b). "Application of Gannett Outdoor Companies for a Variance Concerning Fixed Ladders." **Federal Register** 55: 26796-26797, June 29, 1990. http://www.osha.gov/pls/oshaweb/owadisp.show_document?p_table=FEDERAL_REGISTER&p_id=13085.
- Occupational Safety and Health Administration (OSHA, 1981). Standard Interpretations: 12/02/1981—"Alternating tread type stair is approved as safe for use." http://www.osha.gov/pls/oshaweb/owadisp.show_document?p_table=INTERPRETATIONS&p_id=18983.
- Office of Management and Budget (OMB, 2007). *North American Industry Classification System—2007*. Executive Office of the President, 2007.
- Office of Management and Budget (OMB, 2005). *Regulatory Reform of the U.S. Manufacturing Sector*. March 2005. http://www.whitehouse.gov/sites/default/files/omb/assets/omb/inforeg/reports/manufacturing_initiative.pdf.
- Office of Management and Budget (OMB, 2003). *Regulatory Analysis*. Circular A-4, September 17, 2003. <http://www.whitehouse.gov/omb/circulars/a004/a-4.pdf>.
- Platts.com (Platts, 2007). *2007 UDI Directory of Electric Power Producers and Distributors*, 115th Edition, Electrical World Directory. The McGraw-Hill Companies, 2007.
- Seong, Si Kyung and John Mendeloff (Seong and Mendeloff, 2008). "Assessing the Accuracy of OSHA's Projections of the Benefits of New Safety Standards." *American Journal of Industrial Medicine* 45(4): 313-328, 2004.
- Small Business Administration (SBA, 2010). *Table of Small Business Size Standards Matched to North American Industry Classification System Codes, 2010*. <http://www.sba.gov/content/table-small-business-size-standards>.
- Small Business Administration (SBA, 1996). *Regulatory Flexibility Act of 1980* (Pub. L. 96-354), amended by the *Small Business Regulatory Enforcement Fairness Act of 1996* (Pub. L. 104-121).
- U.S. Census Bureau (Census Bureau, 2002/2006). *Statistics of U.S. Businesses, 2002/2006*. <http://www.census.gov/csd/susb/index.html>.
- U.S. Environmental Protection Agency (U.S. EPA, 2010). *Guidelines for Preparing Economic Analyses*. EPA 240-R-10-001, December 2010. <http://yosemite.epa.gov/ee/epa/eed.nsf/webpages/Guidelines.html>.
- U.S. Internal Revenue Service (IRS, 2013). 2010 Corporation Source Book, Publication 1053. <http://www.irs.gov/uac/SOI-Tax-Stats-Corporation-Source-Book-U.S.-Total-and-Sectors-Listing> Accessed by OSHA on 4/19/2013.
- U.S. Internal Revenue Service (IRS, 2009). *Corporation Source Book*. <http://www.irs.gov/uac/SOI-Tax-Stats-Corporation-Source-Book-U.S.-Total-and-Sectors-Listing>. Accessed, 2009.
- U.S. Internal Revenue Service (IRS, 2003). *Corporation Source Book, 2003*. <http://www.irs.gov/taxstats/bustaxstats/article/0,,id=149687,00.html>.
- Urban Institute/Brookings, 2012. "Historical Average Federal Tax Rates for All Households," Tax Policy Center, October. Available at <http://www.taxpolicycenter.org/taxfacts/displayafact.cfm?Docid=456>.

Viscusi, Kip and Joseph Aldy (Viscusi and Aldy, 2003). "The Value of a Statistical Life: A Critical Review of Market Estimates Throughout the World." *The Journal of Risk and Uncertainty*, 27-1 (2003): 5-76.

Workers' Compensation Research Institute (WCRI, 1993). "Income Replacement in California." *WCRI Research Brief*, Special Edition. Volume 9, number 4S, Cambridge, MA, December 1993. Also available in Docket OSHA-S777-2006-0938 (Ex. 0266).

Wright, Michael C. (Wright, 2003). Comments submitted to OSHA Docket S-029. Michael C. Wright, LJB, Inc. (Ex. OSHA-S029-2006-0662-0350).

Zeolla, Robert J. (Zeolla, 2003). Comments submitted to OSHA Docket S-029. Robert J. Zeolla, Jr., President, Sunset Window Cleaning Company. June 5, 2003 (Ex. OSHA-S029-2006-0662-0348).

Appendix A. Derivation of Prevention Factor Adjustments

To derive possible quantitative adjustment factors from the Seong and Mendeloff study OSHA examined each of their case studies. In most cases, Seong and Mendeloff did not derive a quantitative difference between what happened and what OSHA estimated. Instead their goal was to qualitatively establish that overestimation was routine and in some cases extremely large. To derive quantitative estimates from this data requires making some assumptions. First, OSHA has assumed that all declines that actually occurred are attributable to a new standard. This will tend to overestimate the effectiveness of standards. Second, in some cases declines take place over time, and are significant over the long run but show little effect in the first

year. If there is no decline in early years but a major one thereafter, OSHA has developed two estimates, one based on the first year and one based on what happened over time.

- Scaffolding for General Industry (61 FR 46026, August 30, 1996): OSHA originally predicted that the scaffolding rule would reduce fatalities by 59 percent, whereas Seong and Mendeloff find an actual reduction of 21 percent, yielding a realized-to-projected effectiveness ratio of 0.36 (=0.21/0.59).

- Electrical Work Practices for General Industry (55 FR 31984, August 6, 1990)—OSHA's predicted reduction was 41.4 percent. The actual decrease was negligible immediately upon finalization of the rule and up to 48 percent in the latter portion of the post-implementation decade, thus yielding a range of ratios from 0 (=0/0.414) if the immediate post-implementation result is interpreted as the amount attributable to the rule, or up to 0.61 (=0.25/0.414 where 0.25 is the annualization over a ten-year period with a 7 percent discount rate of a reduction pattern that rises linearly from 0 immediately upon finalization to 48 percent after a decade) if the longer-term reduction is interpreted as attributable to the rule.

- Process Safety Management (PSM) in General Industry (57 FR 6356, February 24, 1992)—OSHA's predicted reduction was 40 percent in the first five years and at least 80 percent in subsequent years, and the actual decrease was a reduction of around 50 percent in the first year (though a substantial portion of this was probably attributable to the rule taking effect in a recession) and then no further decreases in subsequent years, yielding a ratio of 0.88 (=0.54/0.61 where 0.54 and 0.61 are annualizations over a ten-year period with a 7 percent discount rate of the reduction patterns just listed).

- Permit-Required Confined Spaces for General Industry (58 FR 4462, January 14, 1993)—OSHA's predicted reduction was 85 percent, and the actual decrease is described by Seong and Mendeloff as probably at least 50 percent (though the discussion of relative results in greater- and lesser-affected states undermines the claim of the rule's effectiveness), yielding a ratio of 0.59 (=0.5/0.85).

- Electrical Power Generation (59 FR 4320, January 31, 1994)—OSHA's predicted reduction was 68 percent, but actual deaths "dipped in 1993, the year the standard became effective, then went back to their pre-standard levels through 1997," and subsequently dropped by one-third or one-half, depending on the measure used. The resulting ratios range from approximately 0 (=0/0.68) if the immediate post-implementation result is interpreted as the amount attributable to the rule, up to 0.41 (=0.28/0.68 where 0.28 is the annualization over a ten-year period with a 7 percent discount rate of a reduction pattern of zero in the first four years and 50 percent subsequently) if the longer-term reduction is interpreted as attributable to the rule.

- Logging Operations (59 FR 51672, October 12, 1994)—OSHA's predicted reduction was 70 percent, but there is no indication that injuries decreased at all, yielding a ratio of 0 (=0/0.7).

The average of the six ratios ranges from 0.3, if the lower end of a range is used, to 0.47, if the higher end is used.

Appendix B. Fatal Accidents on Walking-Working Surfaces Preventable by the Final Standards (2006-2010 OSHA IMIS)

BILLING CODE 4510-29-P

**Fatal Accidents on Walking-Working Surfaces Preventable by the Final Standards
(2006-2010 OSHA IMIS)**

Accident Summary Number / Accident Inspection Number	Year	Brief Description of Accident	Abstract	SIC: Description	Number of Fatalities	Source of Injury	Event Type	Environmental Factor
Fall From Ladder (Type Unspecified)								
200677102 / 311087571	2007	Employee Is Killed in Fall From Ladder Cleaning Windows	At approximately 11:00 a.m. on December 4, 2007, Employee #1, a window cleaner, was cleaning windows on the fourth floor of a building. The employer provided a boatswain chair, rope, and other window washing equipment and briefly showed Employee #1 how to assemble correctly the metallic ladder. The employer did not provide any job specific training and did not develop a site-specific fall protection plan. Employee #1 was not using any fall protection devices and was not using the boatswain chair that was provided. He was descending a ladder when he lost his balance and fell 30 ft straight down parallel to the ladder and hit the middle section of the ladder before striking his head on the ground. He sustained a blunt trauma to the head and was bleeding through the eyes, mouth and	7349: Building Maintenance Services, NEC	1	Ladder	Fall (From Elevation)	Other
Fall From Fixed Ladders								
202087847 / 309444396	2006	Employee Is Killed in Fall From Fixed Ladder	At approximately 7:15 a.m. on November 27, 2006, Employee #1 was working in the filling/packaging department at a cat litter manufacturing plant. He was ascending a fixed ladder to retrieve a defective package from a conveyor. The ladder was damaged and lightly coated with cat litter dust. Employee #1 was killed when he fell from the 12-ft tall ladder and struck his head on the concrete floor.	2812: Alkalies and Chlorine Manufacturing	1	Ladder	Fall (From Elevation)	Other

**Fatal Accidents on Walking-Working Surfaces Preventable by the Final Standards, continued
(2006-2010 OSHA IMIS)**

Accident Summary Number / Accident Inspection Number	Year	Brief Description of Accident	Abstract	SIC: Description	Number of Fatalities	Source of Injury	Event Type	Environmental Factor
200823839 / 311250302	2008	Employee Dies After Sustaining Leg Injury From Fall	At approximately 8:00 p.m. on May 21, 2008, Employee #1 was feeding a plastic sheet into . . . [a] trim press He used fixed industrial stairs to access the canopy and feed the sheet into the trim press. The stairs to this trim press had a missing top rail on one of the open sides and the rungs had worn slip resistant material. As he worked, he may have slipped or lost his balance, falling from the ladder. He struck the ground and sustained blunt force trauma to his left thigh. The accident was not reported that day, and Employee #1 visited a medical center and emergency room on May 22 and May 23. On the evening of May 23, he was admitted to the intensive care, where he continued to receive treatment, but died at 2:40 a.m. on May 24.	3089: Plastics Products, NEC	1	Bodily Motion	Other	Other
Fall From Step Ladder								
201681913 / 310853262	2009	Employee Is Killed in Fall From Ladder	On January 29, 2009, Employee #1, a truck driver, and Coworker #1, a mechanic, were working on a reefer semi-trailer in the maintenance shop. The refrigeration unit had been removed from the front of the semi-trailer and plywood had been bolted over the hole. Employee #1 and Coworker #1 positioned two portable step ladders in front of the semi-trailer in order to apply sealant on the plywood and semi-trailer seam. Employee #1 climbed a damaged 8-ft step ladder to apply sealant to the top seam. He fell off the ladder onto the concrete floor and suffered severe injuries and died. Although there were no witnesses, it appeared that Employee #1 was standing on the top step of the damaged ladder when he fell. The employer had not provided ladder safety training.	4214: Local Trucking With Storage	1	Ladder	Fall (From Elevation)	Work-Surface/Facil.-Layout Cond.

**Fatal Accidents on Walking-Working Surfaces Preventable by the Final Standards, continued
(2006-2010 OSHA IMIS)**

Accident Summary Number / Accident Inspection Number	Year	Brief Description of Accident	Abstract	SIC: Description	Number of Fatalities	Source of Injury	Event Type	Environmental Factor
200515070 / 314596982	2010	Employee Falls From Ladder and Dies	<p>On June 10, 2010, Employee #1, along with coworker #1, 2, 3, 4 and 5 were on site to do construction work to the interior of a building. They were working on a construction of a new, handicapped building entrance, construction of a new foyer, and construction of a common bathroom area. Employee #1 along with Coworkers #1 and 3 were working on the common bathroom area. Each employee was working independently on different sections of the bathroom. The bathroom was framed in at this point, with some sheet rock already installed. They were continuing installation of sheetrock. Coworker #1 was working near the outside windows (west), Employee #1 was working in the opposite side of the bathroom (east), on the upper, more intricate pieces of the wall, and Coworker #3 was working on the top of a utility closet in the bathroom (central section of bathroom). Each one could see the other one working. Employee #1 was utilizing a step ladder to reach the higher portions of the bathroom. The heights were greater than 10 ft. The step ladder being used was a . . . 12- ft. fiberglass stepladder. The step ladder was propped up against the wall near the corner so Employee #1 could reach the upper corner to finish the pieces surrounding the existing structural steel of the building. Employee #1 was not utilizing the step ladder in accordance with the manufacturer's recommendations . . . Employee #1 remained in the common bathroom area, working, while Coworker #1, 2, 3 and 4 took their lunch breaks . . . Coworker #3 went to the last known working location of Employee #1, the bathroom, and found him lying lifeless at the base of the step ladder he was using. Coworker #3 immediately ran out to the other employees, and called 911. The Minneapolis Police and EMS arrived at the scene. Employee #1 was treated by the EMS, and later pronounced DOA.</p>	6512: Nonresidential Building Operators	1	Working Surface	Fall (From Elevation)	Other

**Fatal Accidents on Walking-Working Surfaces Preventable by the Final Standards, continued
(2006-2010 OSHA IMIS)**

Accident Summary Number / Accident Inspection Number	Year	Brief Description of Accident	Abstract	SIC: Description	Number of Fatalities	Source of Injury	Event Type	Environmental Factor
Fall From Rolling Ladder								
200082865 / 310182233	2007	Employee Is Killed When He Falls	On January 26, 2007, Employee #1 was inventorying material that was stored on metal shelving racks. He was using a rolling ladder to reach the upper shelves of the rack. He could not reach the material stored on an upper shelf located 10 ft off the floor and climbed onto the rack. He fell from the rack and landed on the floor. He received back and head injuries and was hospitalized and died later.	5943: Stationery Stores	1	Ladder	Fall (From Elevation)	Work-Surface/Facil.-Layout Cond.
200263945 / 314914094	2010	Employee Is Killed in Fall From Rolling Ladder Tower	On September 13, 2010, Employee #1, working in the tool department, attempted to assist a customer by climbed a rolling ladder tower to access product located on product racking approximately nine feet from floor level. Employee #1 left the top level of the ladder stand and climbed onto the product rack. Employee #1 then attempted to reboard the ladder stand from the storage rack when he fell approximately 9 feet to the concrete floor. Employee #1 suffered fatal head injuries.	5211: Lumber and Other Building Materials	1	Ladder	Fall (From Elevation)	Other
Fall From Ladder (Others)								
200830990 / 307606905	2006	Employee Is Brain Dead in Fall From Ladder	On February 7, 2006, an employee fell approximately 7 ft, when the portable metal ladder stand that he was using tipped over. The employee suffered severe head trauma and was later pronounced brain dead. A wheel was missing from the ladder at the time of the inspection.	7699: Repair Services, NEC	1	Ladder	Fall (From Elevation)	Other

**Fatal Accidents on Walking-Working Surfaces Preventable by the Final Standards, continued
(2006-2010 OSHA IMIS)**

Accident Summary Number / Accident Inspection Number	Year	Brief Description of Accident	Abstract	SIC: Description	Number of Fatalities	Source of Injury	Event Type	Environmental Factor
202450326 / 309674034	2006	Employee Is Killed in Fall From Platform	<p>On January 12, 2006, Employee #1 was working alone at night, greasing fittings on a loading platform that was 11 feet above the ground. The loading platform consisted of an adjustable ladder leading to a guardrail system, which lowers to the top of a tanker truck when loading. The guardrails become fall protection for employees, when they are opening the valves on the top of the truck. When there are no trucks at the loading platform, the adjustable ladder assembly is kept in the raised, stored position. An automatic foot locks the clips into place over a "pin" or "bolt" to keep the assembly from descending inadvertently. It is believed that Employee #1 leaned against the adjustable ladder assembly while greasing fittings on the platform and the assembly descended unexpectedly, causing him to lose his balance and fall to the ground, striking his head on the concrete pad area, resulting in his death. The accident was not witnessed. Inspection of the ladder assembly revealed that the "pin" or "bolt" part of the foot lock was missing.</p>	2874: Phosphatic Fertilizers	1	Ladder	Fall (From Elevation)	Work-Surface/Facil.- Layout Cond.
202087946 / 309444941	2007	Employee Dies in Fall From Crane	<p>At approximately 12:15 a.m. on January 12, 2007, Employee #1 was working as part of a crew that was cleaning and serving a 370-[t]on . . . [c]rane. The maintenance crew had parked and locked out the crane, and removed the worm gear box casing, so that the service crew could access the worm gear. The trolley was parked approximately 90-in. away from the trolley stop. This left one side of the platform open to an approximate 110 ft to 115 ft fall hazard. Employee #1 was descending a 6-ft metal rung ladder from the bridge of the crane and was killed when he slipped and fell while attempting to place his foot on the trolley rail. He struck the crane during his fall and landed on the new worm gear which was lying on the ground.</p>	8999: Services, NEC	1	Working Surface	Fall (From Elevation)	Work-Surface/Facil.- Layout Cond.

**Fatal Accidents on Walking-Working Surfaces Preventable by the Final Standards, continued
(2006-2010 OSHA IMIS)**

Accident Summary Number / Accident Inspection Number	Year	Brief Description of Accident	Abstract	SIC: Description	Number of Fatalities	Source of Injury	Event Type	Environmental Factor
200555217 / 311523609	2008	Employee Falls From Ladder, Later Dies	At approximately 8:30 a.m. on April 15, 2008, Employee #1 was descending a ladder on oil drilling rig #6. Employee #1 was wearing a body harness that was hooked into the rig's counter weighted ladder climbing device. For some reason, the self-retracting lifeline was not in place. Employee #1 fell approximately 60 ft to the rig floor. Employee #1 sustained head and back injuries. Employee #1 was flown to a local hospital, where he died on April 17, 2008.	1381: Drilling Oil and Gas Wells	1	Working Surface	Fall (From Elevation)	Other
201282910 / 311037931	2008	Employee Dies After Fall From Ladder	At approximately 8:15 a.m. on February 18, 2008, Employee #1 responded to a call to repair a leaking tractor-trailer. Upon arrival at the site, Employee #1 used a 12-foot folding ladder to reach the top of the trailer, which measured 13.25 feet high. While sealing the leak, Employee #1 fell from the ladder. He landed on his back and struck his head on the ground. Employee #1 was taken to a nearby hospital, where he died.	7549: Automotive Services, NEC	1	Bodily Motion	Struck Against	Work-Surface/Facil.- Layout Cond.
200997674 / 313126807	2009	Employee Falls From Crane	On June 6, 2009, Employee #1, a maintenance supervisor . . . was on a charging crane, he was going up an 88-foot vertical ladder on the crane trolley, while his crew was about to-do a cable change on the 75-ton auxiliary hook. Employee #1 slipped off the ladder and fell backwards approximately 80 feet to the ground, he was also observed hitting a spreader beam on the floor level during the fall and severing his right leg. Employee #1 was pronounced dead at the scene by paramedics and the Coroner Investigator. No fall protection equipment was used by Employee #1 or any the other employees on the crew. Fall protection was available by company and Employee #1 had knowledge of its availability.	3312: Blast Furnaces and Steel Mills	1	Ladder	Fall (From Elevation)	Work-Surface/Facil.- Layout Cond.

**Fatal Accidents on Walking-Working Surfaces Preventable by the Final Standards, continued
(2006-2010 OSHA IMIS)**

Accident Summary Number / Accident Inspection Number	Year	Brief Description of Accident	Abstract	SIC: Description	Number of Fatalities	Source of Injury	Event Type	Environmental Factor
201682085 / 314284340	2010	Employee Is Killed in Fall From Ladder	On September 8, 2010, Employee #1 was retrieving items from a warehouse shelving unit. She used a 14-ft . . . roll[ing] ladder, and she fell to the ground. She was found cold, unconscious and lying on her back at the base of the ladder. The safety brake mechanism on the ladder was disengaged, and it was reported that Employee #1 had been experiencing dizzy spells for the past week. Employee #1 was killed.	4226: Special Warehousing and Storage, NEC	1	Ladder	Fall (From Elevation)	Other
Fall From Roof								
201773066 / 310364385	2006	HVAC Maintenance Worker Falls Off Roof and Killed	On October 27, 2006, a maintenance contractor was on the roof of a building to service an HVAC unit. He fell approximately 25 feet from the roof, and was killed.	7349: Building Maintenance Services, NEC	1	Buildings / Structures	Fall (From Elevation)	Other
201751575 / 309197861	2006	Employee Is Killed in Fall From Roof	At approximately 3:27 p.m. on October 17, 2006, an employee was up on the roof 25 feet from the ground winterizing a swamp-cooler. At the time of the accident, the employee was putting on the side panels of the swamp-cooler, when he lost his footing and fell down 10-ft to the second level and then to the ground striking his head on the pavement as he landed. He was semi-conscious, when he was transported to the hospital where he remained until his death on October 22, 2006. At the time of the accident, the employe[r] did not have a fall protection system in place.	5812: Eating Places	1	Ladder	Fall (From Elevation)	Work-Surface/Facil.- Layout Cond.

**Fatal Accidents on Walking-Working Surfaces Preventable by the Final Standards, continued
(2006-2010 OSHA IMIS)**

Accident Summary Number / Accident Inspection Number	Year	Brief Description of Accident	Abstract	SIC: Description	Number of Fatalities	Source of Injury	Event Type	Environmental Factor
200355691 / 310498415	2006	Employee Is Killed After Being Engulfed in Silo	On September 24, 2006, Employee #1, a mill supervisor, was working alone at a country animal feed grain mill. He climbed 55 ft up a 70 ft caged ladder mounted between two wet corn silos. Employee #1 then cross over a guardrail and proceeded across the silo's conical-shaped, 30-degree-sloped roof. He opened a roof access hatch that measured 30-in. wide by 36-in. long, which led to an area classified as a permit-required confined space. After Employee #1 could not be located, rescue operations were initiated at 2:10 p.m. Emergency responders removed approximately 30,000 bushels of corn by hand before finding Employee #1 at 2:01 a.m. the following morning. He was killed. Employee #1 was not wearing fall protection equipment even though the equipment was available.	2048: Prepared Feeds, NEC	1	Dust / Particles/ Chips	Other	Work-Surface/Facil.- Layout Cond.
200901890 / 307412270	2006	Employee Sustains Concussion, Is Killed in Fall Through Roof	On August 4, 2006, Employee #1 was working for a firm that provided building cleaning and maintenance services. He fell through a roof and sustained a concussion. He was killed.	7349: Building Maintenance Services, NEC	1	Buildings / Structures	Fall (From Elevation)	Other
202260758 / 308100460	2006	Employee Is Killed in Fall From Roof	On July 5, 2006, Employee #1 was changing a photoelectric cell of an outdoor lamp, located on the roof of the second-story building. Employee #1 fell to the ground from the building roof approximately 20 ft. He sustained bruises, contusions, and abrasions. Employee #1 was transported to the hospital, where he died a few hours later.	8999: Services, NEC	1	Other	Fall (From Elevation)	Other
201282258 / 309617694	2006	Employee Is Killed in Fall From Trailer	On May 25, 2006, Employee #1 was covering a trailer full of bark with a tarp, when he lost his balance. He fell approximately 10 ft and landed upon the ground, sustaining severe head trauma that killed him.	2431: Millwork	1	Motor Vehicle (Indus)	Fall(From Elevation)	Work-Surface/Facil.- Layout Cond

**Fatal Accidents on Walking-Working Surfaces Preventable by the Final Standards, continued
(2006-2010 OSHA IMIS)**

Accident Summary Number / Accident Inspection Number	Year	Brief Description of Accident	Abstract	SIC: Description	Number of Fatalities	Source of Injury	Event Type	Environmental Factor
201353026 / 308436013	2006	Employee Is Killed in Fall From Roof	On February 1, 2006, Employee #1 was working as a heating, ventilation, and air conditioning (HVAC) mechanic, performing scheduled maintenance on the HVAC units at a . . . restaurant. There were three HVAC units on the restaurant roof, which was about 15-foot high. Along the edge of the roof, there was a 15-inch wide, 19-inch high parapet. Employee #1 climbed a portable metal ladder and took a garden-type water hose, connected to a spigot at ground level, onto the roof. Carrying the hose to the opposite side of the roof from where the ladder was located, he apparently walked either backward or sideways, not watching where he was walking. He walked into the parapet wall and fell from the roof, sustaining injuries to his head, knees, left hand, and left wrist. He was taken to a local hospital, where he was pronounced dead. The cause of death was a closed head injury due to blunt impact to his head and neck. His injuries included head fractures, hemorrhage, and contusions.	7623: Refrigeration Service and Repair	1	Working Surface	Fall (From Elevation)	Work-Surface/Facil.- Layout Cond.
202461596 / 310112602	2006	Employee Falls From Elevation and Is Killed	On May 9, 2006, an employee was engaged in a roof cleaning operation consisting of cleaning lint collection traps from dryer stacks. A forklift basket attachment, not secured to the forklift blades, containing cleaning equipment, was lifted to the roof approximately 20 ft above the ground. Upon completion of the cleaning operation, the employee stepped onto the basket attachment to load a hand truck, when the attachment flipped off the forks. The employee fell from the attachment onto a metal tote located at ground level. The employee was then struck by the falling attachment, which weighed approximately 400 lbs. The employee was transported to . . . [the h]ospital where he died from chest trauma at approximately 6:00 p.m.	7218: Industrial Launderers	1	Other	Struck By	Other

**Fatal Accidents on Walking-Working Surfaces Preventable by the Final Standards, continued
(2006-2010 OSHA IMIS)**

Accident Summary Number / Accident Inspection Number	Year	Brief Description of Accident	Abstract	SIC: Description	Number of Fatalities	Source of Injury	Event Type	Environmental Factor
200023240 / 309779502	2006	Employee Is Killed in Fall From Roof	Employee #1 was passing from one section of a roof to another when he fell approximately 17.5 feet from the roof edge to the concrete sidewalk and was killed.	7349: Building Maintenance Services, NEC	1	Working Surface	Fall (From Elevation)	Work-Surface/Facil.-Layout Cond.
200676393 / 310210455	2006	Employee Is Killed in Fall From Roof	Employee #1 was working on the roof installing safety lines and fell approximately 45 ft to the ground. Employee #1 was killed.	5039: Construction Materials, NEC	1	Materials Handlg Eq.	Struck By	Materials Handlg. Equip./Method
201169430 / 126199819	2007	Employee Is Killed in Fall From Roof	At 2:54 p.m. on December 26, 2007, Employee#1, an apartment building maintenance worker, was patching a roof leak approximately 25 feet from the edge of a building's roof. Employee #1 was killed when he fell approximately 26 feet from the edge of the roof over the building's boiler room to an interior courtyard below. An investigation was pending.	6531: Real Estate Agents and Managers	1	Other	Fall (From Elevation)	Weather, Earthquake, Etc.
200677029 / 311086672	2007	Employee Is Killed in Fall From Sloped Roof	At 9:00 p.m. on October 19, 2007, Employee #1 was painting a sloped roof of a gas station, with use of the artificial portable lamps. He was working from the top of the tile roof where the eave was 12-ft., 4-in. high. Employee #1 slipped and fell to the ground. He was transported to a local hospital and remained in a coma until October 25, 2007, when he died. There were no actual eye witnesses to the accident. Employee #1 was not wearing a fall protection at the time of accident.	9999: Non-classifiable Establishments	1	Other	Fall (From Elevation)	Overhead Moving/Falling Obj. Accid.
201762945 / 311063762	2007	Employee Is Killed in Fall From Roof	On July 23, 2007, Employee #1 was on a roof cleaning cooking vents. His supervisor heard a loud noise and found Employee #1 on the ground. Employee #1 was pronounced dead at the hospital.	5812: Eating Places	1	Buildings/ Structures	Fall (From Elevation)	Work-Surface/Facil.-Layout Cond.

**Fatal Accidents on Walking-Working Surfaces Preventable by the Final Standards, continued
(2006-2010 OSHA IMIS)**

Accident Summary Number / Accident Inspection Number	Year	Brief Description of Accident	Abstract	SIC: Description	Number of Fatalities	Source of Injury	Event Type	Environmental Factor
200603660 / 311308225	2007	Employee Killed in Fall From Roof	On July 19, 2007, Employee #1 was attempting to step onto a ladder from a roof when he fell to the ground, and suffered fatal injuries.	7342: Disinfecting & Pest Control Services	1	Ladder	Fall (From Elevation)	Other
201773090 / 310952981	2007	Employee Is Killed in Fall During Refrigeration Installation	On May 31, 2007, an employee was installing a refrigeration unit on the roof. There was a sudden release of air which startled the employee. The employee stepped back and fell 42 feet. The employee was killed.	4222: Refrigerated Warehousing and Storage	1	Working Surface	Fall (From Elevation)	Work-Surface/Facil.-Layout Cond.
200090603 / 310156914	2007	Employee Is Killed in Fall	Employee #1 was a property manager for a hospital. Employee #1 was performing a roof examination in an area that had been repaired several times. Employee #1 had been assigned to the roof top chiller replacement project which was near[ing] . . . completion. Employees of the roofing company that did the chiller replacement were on the roof completing punch list items for final payment. Employee #1 fell 150 ft and was killed.	8062: General Medical & Surgical Hospitals	1	Other	Fall (From Elevation)	Other
200823466 / 309770055	2007	Employee Is Asphyxiated When Engulfed in Sand	At approximately 2:30 p.m. on January 17th, 2007, Employee #1 was on the roof of a building next to the hopper of sand attempting to break the frozen sand loose in the hopper. Employee #1 fell into the hopper and became engulfed. There was no fall protection provided for Employee #1 working around the hopper or on the roof. Employee #1 was asphyxiated.	3272: Concrete Products, NEC	1	Dirt / Sand / Stone	Caught in or Between	Work-Surface/Facil.-Layout Cond.

**Fatal Accidents on Walking-Working Surfaces Preventable by the Final Standards, continued
(2006-2010 OSHA IMIS)**

Accident Summary Number / Accident Inspection Number	Year	Brief Description of Accident	Abstract	SIC: Description	Number of Fatalities	Source of Injury	Event Type	Environmental Factor
200841732 / 309292282	2008	Fatal Fall From A Roof	<p>On November 05, 2009, at approximately 9:40 AM, Employees #1 and #2 were performing roofing work on the roof of building #3 at [a steel plant]. The employees were replacing 27.5-in. wide and 10-ft., 6-in. long, 2.5-in. corrugation, light green translucent roof sheets with 35.5-in. by 12-ft. corrugated sheet metal. Both employees were exposed to 40 ft., 7 in. fall hazards from the eave of the roof and an approximate 70-ft. fall hazard through a fiberglass panel that gave way under the weight of the . . . accident victim. Both employees were wearing harnesses; however, neither employee was tied off at the time of the accident. The lifeline was connected by placing a locking type snap hook at the peak of the roof, in such a manner, as to negate the locking mechanism of the snap hook. At the time of the . . . accident, both employees were installing the last piece of corrugated sheet metal. As Employee #1 was screwing in the corrugated sheet metal, Employee #2 was standing beside and a little behind Employee #1, in order to help hold him in place due to the slippery condition of the corrugated sheet metal. Employee #2 slipped and fell backward through a fiberglass panel, which gave way under Employee #2's weight. Employee #2 fell approximately 70 ft. to his death into the interior of the building. Employee #2 landed on a dirt floor, inside the building. Employee #2 died from severe brain trauma.</p>	3312: Blast Furnaces and Steel Mills	1	Buildings / Structures	Fall (From Elevation)	Work-Surface/Facil.-Layout Cond.

**Fatal Accidents on Walking-Working Surfaces Preventable by the Final Standards, continued
(2006-2010 OSHA IMIS)**

Accident Summary Number / Accident Inspection Number	Year	Brief Description of Accident	Abstract	SIC: Description	Number of Fatalities	Source of Injury	Event Type	Environmental Factor
202549242 / 309303717	2008	Employee Is Killed in Fall From Roof	On October 30, 2008, Employee #1 was in the process of installing a fumigation tent over a two-story residence. After erecting a 24 ft extension ladder, he carried a tarp bundle, weighing approximately 120 lb to the roof. As he sat the bundle on the roof, he lost his balance, causing him to slide off the roof. The roof had an approximate slope of 30 degrees. During the fall, the bundle hit a roof extension on the first story before hitting the ground level. Employee #1 cleared the first story roof, but struck the concrete walkway on the ground level, killing him. He fell about 18 feet.	7342: Disinfecting & Pest Control Services	1	Other	Fall (From Elevation)	Other
200631927 / 311683684	2008	Employee Is Killed in Fall From Roof to Warehouse Floor	At 1:30 p.m. on Sunday, July 20, 2008, a storm with strong winds and heavy rain came through the Weirton, West Virginia area, setting off a fire alarm sensor and damaging the roof of the 12th Street Warehouse at the Eagle Manufacturing Company. Company officials made a decision that afternoon to have the maintenance crew clean up the damage area the following morning. Once the debris was removed, the maintenance crew covered the area with a tarp, and a contractor would be called in to do the repairs. The employees had just finish removing the damaged layer of roofing and insulation, and were leaving the roof area, when Employee #1, instead of traveling back over the good area of the roof, walked across the damage area. Employee #1 fell through a soft spot, falling approximately 35 feet to the floor of the warehouse. Employee #1 suffered head injuries, and died while on the way to the hospital.	3999: Manufacturing Industries, NEC	1	Working Surface	Fall (From Elevation)	Other

**Fatal Accidents on Walking-Working Surfaces Preventable by the Final Standards, continued
(2006-2010 OSHA IMIS)**

Accident Summary Number / Accident Inspection Number	Year	Brief Description of Accident	Abstract	SIC: Description	Number of Fatalities	Source of Injury	Event Type	Environmental Factor
200002749 / 312215882	2008	Employee Is Killed in Fall From Roof	At approximately 8:00 a.m. on June 18, 2008, an employee was working on the roof of a modular home section that had been constructed inside the company's facility in Boonville, MO. The employee was preparing a unit for transport. Specifically, he was covering the roof with a protective plastic wrap. He fell 13.8 feet to a concrete floor. The employee was transported by medical helicopter to the University of Missouri Hospital in Columbia, MO, where he died shortly after his arrival.	2452: Prefabricated Wood Buildings	1	Working Surface	Fall(From Elevation)	Work-Surface/Facil-Layout Cond
201391745 / 308815588	2008	Employee Is Killed in Fall From Roof	On April 1, 2008, Employee #1, a maintenance foreman, was working alone and was notified that the belt that opened the flue damper vent to the furnace had broken. He climbed a fixed ladder to access the roof to investigate the problem with the flue. He fell through the roof, landing on the furnace room floor approximately 30 feet below. He died from the impact of landing on the furnace room floor.	3341: Secondary Nonferrous Metals	1	Working Surface	Fall (From Elevation)	Other
201169711 / 126201045	2008	Employee Is Killed When He Falls From Roof	On March 4, 2008, Employee #1 and a building manager were making measurements on the flat roof of a 3-story apartment building, using a 50-ft tape measure. The building was 30 feet high and had a 2-ft parapet wall. They started at the North side of the roof, and progressed to the South side. At the 200 feet mark, the manager bent down to hold one end of the tape while Employee #1 walked backwards with the tape toward the parapet wall. When the manager turned around to face the parapet wall, Employee #1 had fallen off the roof. There had been no fall arrest systems, personal fall restraint or positioning system provided. Employee #1 was killed in the fall.	6531: Real Estate Agents and Managers	1	Other	Fall (From Elevation)	Work-Surface/Facil-Layout Cond
201573391 / 310472055	2008	Employee Falls From Roof and Is Killed	On February 28, 2008, Employee #1 was cleaning ice and snow off the roof of a hotel, and he slid off the roof. He fell approximately six stories. Employee #1 was killed.	3444: Sheet Metal Work	1	Working Surface	Fall(From Elevation)	Weather, Earthquake, Etc.

**Fatal Accidents on Walking-Working Surfaces Preventable by the Final Standards, continued
(2006-2010 OSHA IMIS)**

Accident Summary Number / Accident Inspection Number	Year	Brief Description of Accident	Abstract	SIC: Description	Number of Fatalities	Source of Injury	Event Type	Environmental Factor
200555951 / 313028276	2009	Employee Is Killed in Fall From Unguarded Roof	On December 21, 2009, Employee #1 was replacing damaged polyethylene sheeting on an existing exterior of a building with an unguarded roof edge. He did not have fall protection. During his work, he lost his balance and fell approximately 11 ft to the ground. He struck the ground and was killed.	7539: Automotive Repair Shops, NEC	1	Working Surface	Fall(From Elevation)	Work-Surface/Facil-Layout Cond
201074291 / 312679921	2009	Worker Erecting Fumigation Tent Is Killed in Fall From Roof	At approximately 9:00 a.m. on October 5, 2009, Employee #1 was working fulltime for a pest control company. He and a coworker had arrived at a two-story, detached, single-family home at about 8:00 a.m. and were erecting a tent around it to fumigate it. Employee #1 was on the roof, when he fell approximately 19 feet. He landed on a wooden fence on the south side of the house and sustained a fractured neck. The coworker called emergency services, and the Oceanside, CA, Fire Department responded. Employee #1 was pronounced dead at the scene	7342: Disinfecting & Pest Control Services	1	Other	Fall(From Elevation)	Other
201638780 / 313477267	2009	Employee Is Killed in Fall From Roof	On September 15, 2009, Employee #1, a service technician, was moving a satellite dish on a roof when he lost his balance. He slid down the roof and fell approximately 10 ft to the ground below. Employee #1 died.	4841: Cable and Other Pay TV Services	1	Working Surface	Fall (From Elevation)	Work-Surface/Facil-Layout Cond
200514891 / 313731770	2009	Employee Is Killed Falling From A Roof	On September 3, 2009, Employee #1 and a coworker, fell from a roof edge while window washing. The coworker, on a boatswains chair, fell from edge due to counter weights not installed on outrigger. Employee #1 fell from the roof after grabbing the outrigger in an attempt to stop it from falling off roof edge. Employee #1 was killed.	7349: Building Maintenance Services, NEC	1	Working Surface	Fall (From Elevation)	Other
200925287 / 313390163	2009	Worker Is Killed in Fall From Roof	Between 3:35 p.m. and 4:25 p.m. on June 10, 2009, Employee #1, of . . . Corporation, was installing an antenna on a roof. He fell 30-40 feet to the pavement and died.	3829: Measuring & Controlling Devices, NEC	1	Other	Fall (From Elevation)	Other

**Fatal Accidents on Walking-Working Surfaces Preventable by the Final Standards, continued
(2006-2010 OSHA IMIS)**

Accident Summary Number / Accident Inspection Number	Year	Brief Description of Accident	Abstract	SIC: Description	Number of Fatalities	Source of Injury	Event Type	Environmental Factor
201781168 / 109332866	2009	Employee Falls From Roof, Later Dies	At approximately 5:00 p.m. on March 13, 2009, Employee #1 was working alone removing old paint using a water blast machine on a flat roof of a building, when he fell approximately 35 ft from the edge of the roof. Employee #1 was taken to the hospital, where he later died from his injuries.	5999: Misc. Retail Stores, NEC	1	Other	Fall (From Elevation)	Other
200925600 / 312945629	2009	Employee Dies After Fall From Roof	On February 10, 2009, Employee #1 was an inspector for a company that performed special inspections. He was on the roof of a four story residential building being constructed. The roof had a 5:12 pitch. He was expecting the nail pattern for the roof sheathing and was walking along the ridge. He lost his footing, slid down the roof, and fell approximately 40 to 45 ft to the ground. Employee #1 died at the hospital. He had not been wearing a harness with a secured lanyard nor was he otherwise protected from fall hazards while performing this job.	8711: Engineering Services	1	Buildings / Structures	Fall (From Elevation)	Work-Surface/Facil.- Layout Cond.
314190943 / 314190943	2010	Employee Is Killed in Fall From Roof	On September 23, 2010, Employee #1 was located on the roof of a three-story building to remove a tree limb that was too close to the roof, causing damage. As Employee #1 cut the limb with a hand saw, it broke prematurely due to the weight on the cut. Employee #1 was knocked from the roof, landing on the lower level of the building, and was killed. The accident investigation revealed that Employee #1 was not wearing any type of fall arrest equipment at the time of the incident.	6513: Apartment Building Operators	1	Hand Tool (Manual)	Fall (From Elevation)	Work-Surface/Facil.- Layout Cond.
202560942 / 314424573	2010	Worker Is Killed After Falling From Roof	On April 18, 2010, Employee #1, of [a restaurant], was conducting maintenance work on an air conditioning unit. While working on air conditioning unit, Employee #1 fell from roof and died. No other information was provided.	5812: Eating Places	1	Ladder	Fall (From Elevation)	Other

**Fatal Accidents on Walking-Working Surfaces Preventable by the Final Standards, continued
(2006-2010 OSHA IMIS)**

Accident Summary Number / Accident Inspection Number	Year	Brief Description of Accident	Abstract	SIC: Description	Number of Fatalities	Source of Injury	Event Type	Environmental Factor
202080438 / 314309139	2010	Employee Dies After Fall From Roof	On February 23, 2010, Employee #1 was inspecting a roof, when he fell approximately 23 feet to the ground. He died from his injuries on March 10, 2010.	6411: Insurance Agents, Brokers, & Service	1	Other	Fall (From Elevation)	Other
201720398 / 313453821	2010	Employee Is Killed in Fall From Metal Roof	On January 27, 2010, Employee #1 was working on approximately 30-ft high metal roof. The aluminum metal sheet was deteriorated and broke under his weight. Employee #1 fell to the ground and was taken to the hospital. Employee #1 died later that day. He was not using a fall arrest system.	5093: Scrap and Waste Materials	1	Working Surface	Fall (From Elevation)	Work-Surface/Facil.- Layout Cond.
Fall Through Skylight								
200623890 / 310305727	2006	Worker Is Killed in Fall Through Skylight	On August 7, 2006, Employee #1 was working for a firm that made fabricated structural metal products. Along with two coworkers, he was on a roof conducting maintenance work. While walking on the roof back to an aerial lift, he fell through a skylight. He sustained a head injury, and he was killed.	3448: Prefabricated Metal Buildings	1	Working Surface	Fall (From Elevation)	Work-Surface/Facil.- Layout Cond.
201330925 / 310189584	2006	Employee Is Killed in Fall Through Skylight	Employee #1 was working on the roof of a structure, when he fell through a skylight. He was killed.	6513: Apartment Building Operators	1	Buildings / Structures	Fall (From Elevation)	Work-Surface/Facil.- Layout Cond.

**Fatal Accidents on Walking-Working Surfaces Preventable by the Final Standards, continued
(2006-2010 OSHA IMIS)**

Accident Summary Number / Accident Inspection Number	Year	Brief Description of Accident	Abstract	SIC: Description	Number of Fatalities	Source of Injury	Event Type	Environmental Factor
200901841 / 307411108	2006	Employee Is Killed in Fall From Skylight Opening	On July 11, 2006, Employee #1 was instructed by his supervisor to caulk the edges of a skylight on the facility's metal roof to prevent water from leaking down onto the working surface of the roof set department. Once Employee #1 completed the job, he asked his supervisor come back up to the roof and look at the finished project. As the supervisor Employee #1 approached the repaired skylight, Employee #1 stepped onto the skylight with his left foot. Employee #1 fell through the skylight and the skylight opening onto the concrete floor below. Employee was fatally injured as a result of the accident.	2452: Prefabricated Wood Buildings	1	Working Surface	Fall (From Elevation)	Other
201992492 / 310281589	2006	Employee Is Killed in Fall Through Skylight	At approximately 5:19 p.m. on July 5, 2006, Employee #1 was cleaning a roof. He fell through the skylight and was killed.	4225: General Warehousing and Storage	1	Bodily Motion	Fall (From Elevation)	Work-Surface/Facil.- Layout Cond.
201320843 / 309858801	2006	Employee Is Killed in Fall Through Apartment Roof Skylight	On June 22, 2006, Employee #1 and a coworker were working as maintenance employees. They were changing a condenser unit on the roof of an apartment building. Employee #1 was transporting the replacement unit on a hand truck, when he tripped and fell through a skylight. He fell approximately twenty-five feet, and he was killed.	6513: Apartment Building Operators	1	Buildings / Structures	Fall (From Elevation)	Materials Handlg Equip./Method
200530665 / 308265891	2006	Mechanic Is Killed in Fall Through Skylight	On May 2, 2006, Employee #1 was performing maintenance on a roof-top air conditioning unit. He fell through a skylight and was killed.	7623: Refrigeration Service and Repair	1	Other	Fall (From Elevation)	Other
200373942 / 309796928	2006	Employee Is Killed in Fall Through Skylight	Employee #1 and a coworker were cleaning out gutters from the roof of a warehouse. Employee #1 fell approximately 18 feet through a fiberglass skylight to the concrete floor. Employee #1 was killed.	5211: Lumber and Other Building Materials	1	Other	Fall (From Elevation)	Other

**Fatal Accidents on Walking-Working Surfaces Preventable by the Final Standards, continued
(2006-2010 OSHA IMIS)**

Accident Summary Number / Accident Inspection Number	Year	Brief Description of Accident	Abstract	SIC: Description	Number of Fatalities	Source of Injury	Event Type	Environmental Factor
200514602 / 311662720	2007	Employee Is Killed in Fall Through Skylight	On December 5, 2007, Employee #1 was clearing ice on top of a roof and fell through skylight and died.	7349: Building Maintenance Services, NEC	1	Other	Fall (From Elevation)	Work-Surface/Facil.-Layout Cond.
202472114 / 311332241	2007	Employee Dies in Fall Through Skylight	Employee #1 and a coworker were reroofing a metal roof on an existing warehouse, approximately 40 feet from the ground. The roof had fiberglass skylights, which had begun to leak and were being covered over by the new roof. They had covered approximately one-half of the 10-ft by 12-ft skylight, when Employee #1 fell through the skylight. Employee #1 sustained severe internal injuries from the 40-foot fall and died later in the day at the hospital.	3441: Fabricated Structural Metal	1	Buildings / Structures	Fall (From Elevation)	Work-Surface/Facil.-Layout Cond.
201262219 / 311120968	2007	Employee Killed By Fall Through Roof Skylight	On June 29, 2007, at approximately 12:30 p.m., Employee #1 was killed as a result of a 30-foot fall through a skylight on the roof. Employee #1 was paired with another worker painting HVAC units on the roof as part of the company's yearly maintenance program. The employer did not provide fall protection barrier guards around the skylight, or personal fall protection for the employees working adjacent to the skylight. The weather conditions were hot, and the employees were taking a break near the skylight. An eyewitness stated that Employee #1 sat on the edge of the skylight and fell through it to the ground. Employee #1 was attended on the ground by plant employees until Emergency Medical help arrived. Employee #1 was transported to . . . [the h]ospital . . . where he died.	3411: Metal Cans	1	Buildings / Structures	Fall (From Elevation)	Other

**Fatal Accidents on Walking-Working Surfaces Preventable by the Final Standards, continued
(2006-2010 OSHA IMIS)**

Accident Summary Number / Accident Inspection Number	Year	Brief Description of Accident	Abstract	SIC: Description	Number of Fatalities	Source of Injury	Event Type	Environmental Factor
202473849 / 307185066	2007	Employee Is Injured in Fall Through Skylight, Later Dies	On June 15, 2007, an employee, a general laborer, was on the roof of the building, alone, and engaged in cleaning a skylight with a broom. The broom broke, and he lost his balance, falling through the unguarded skylight. The employee fell over 15 feet to the concrete floor below. The employee was not wearing any personal fall protection gear such as a harness, lanyard, etc. No means of fall protection was used at the jobsite at the time of the incident. The employee's supervisor was not onsite, but was aware of the task that the employee was performing. The employer did not establish safe procedures for employees to follow when cleaning skylights, such as the use of personal fall protection devices and/or guardrails. A coworker was working inside the building, and took the employee to . . . [the h]ospital. The employee sustained internal injuries and was treated and released from the hospital after five days. The employee died eight days after the incident.	6531: Real Estate Agents and Managers	1	Other	Fall (From Elevation)	Other
201371119 / 310226568	2007	Employee Is Killed in Fall Through Skylight	On February 15, 2007, an employee, a second shift foreman fell through a skylight, while traversing across the snow covered roof of the foundry while en route to the sand bin house. As he approached the northwest corner of the roof, he stepped on the corner of the snow covered sky light. He apparently lost his balance and fell onto the dome shaped plastic cover. The cover broke under his weight causing him to fall approximately 30 feet to the concrete floor of the foundry. Several coworkers immediately ran to his aid and called the emergency medical services. He was made comfortable until the paramedics arrived, who attempted cardio pulmonary resuscitation. The employee was non-responsive and was transported to the . . . hospital . . . where he was pronounced dead . . .	3321: Gray and Ductile Iron Foundries	1	Working Surface	Fall (From Elevation)	Work-Surface/Facil.- Layout Cond.

**Fatal Accidents on Walking-Working Surfaces Preventable by the Final Standards, continued
(2006-2010 OSHA IMIS)**

Accident Summary Number / Accident Inspection Number	Year	Brief Description of Accident	Abstract	SIC: Description	Number of Fatalities	Source of Injury	Event Type	Environmental Factor
202367744 / 312566276	2008	Employee Is Killed in Fall	On October 23, 2008, Employee #1 fell through a skylight to a concrete floor and was killed.	5734: Computer and Software Stores	1	Other	Fall (From Elevation)	Other
200033264 / 311376826	2008	Employee Is Killed in Fall From Roof	On September 14, 2008, Employee #1, a trailer mechanic . . . and other trailer mechanics were instructed to seal portions of the roof from the leaks. The trailer mechanics were instructed to do this job twice a year. Employee #1 was working at the Northeast corner of the roof. While sealing the roof, he fell through a skylight 18 ft to the ground. Employee #1 was killed. None of the working trailer mechanics was wearing fall protection.	7539: Automotive Repair Shops, NEC	1	Buildings / Structures	Fall (From Elevation)	Other
202549366 / 309303055	2008	Employee Falls Through Skylight, Later Dies	On September 9, 2008, Employee #1 was installing corrugated sheet metal decking on top of the existing metal decking on the roof of a 32-ft. high industrial building. There were several skylights on the roof covered by translucent green plastic sheets, approximately 16 ft. by 3 ft. The plastic covering for the skylights also needed replacing. Employee #1 was replacing one of the skylight covers. He removed the old cover and had not yet installed the new cover when he fell through the opening to the trash processing area. He struck a metal hopper, approximately 20 ft below, and then fell another 10 ft to the floor. Employee #1 suffered multiple skeletal and visceral injuries and died later at the hospital.	4212: Local Trucking Without Storage	1	Other	Fall (From Elevation)	Other

**Fatal Accidents on Walking-Working Surfaces Preventable by the Final Standards, continued
(2006-2010 OSHA IMIS)**

Accident Summary Number / Accident Inspection Number	Year	Brief Description of Accident	Abstract	SIC: Description	Number of Fatalities	Source of Injury	Event Type	Environmental Factor
201763059 / 311661094	2008	Employee Is Killed in Fall Through Skylight	<p>On January 7, 2008, Employee #1, a journeyman lineman, was working as part of a four-man crew to replace a burned-out, pole-mounted transformer. The pole was inaccessible by truck because of its proximity to an industrial strip center on its south side and a drainage ditch, with a slope of approximately 12 degrees, on its north side. The pole was located approximately 253 feet east of a hard-surface parking lot. The crew determined that they would replace the transformer manually, using a jib, blocks, and generator-powered electric cathead. The crew had difficulty lowering the old transformer to the ground because the industrial strip center, located 66 inches south of the pole, prevented a good angle on the tag lines. However, they did successfully remove the old transformer. Because of the difficulty they had experienced in removing the old transformer, the crew decided that they would raise the new transformer to the level of the roof and then throw the tag lines onto the roof. The crew thought this would result in a better tag line angle, which would allow them to pull the transformer away from the pole and facilitate positioning and bolting it into place. The cathead was used to raise the transformer to the level of the roof, and Employee #1 threw his tag line onto the roof. Employee #1 and a helper then walked over to a ladder, which was erected approximately 240 feet west of the pole. They climbed the ladder and walked east across the 1 to 12 pitch metal roof of the industrial strip center building. The helper walked east along the edge of the building, while Employee #1 walked southeast, approximately 50 feet. Employee #1 stepped onto a fiberglass skylight and fell approximately 17 feet to the concrete floor of the shop. Employee #1 was killed and declared dead at the scene.</p>	4911: Electric Services	1	Working Surface	Fall (From Elevation)	Work-Surface/Facil.-Layout Cond.

**Fatal Accidents on Walking-Working Surfaces Preventable by the Final Standards, continued
(2006-2010 OSHA IMIS)**

Accident Summary Number / Accident Inspection Number	Year	Brief Description of Accident	Abstract	SIC: Description	Number of Fatalities	Source of Injury	Event Type	Environmental Factor
202529566 / 309915676	2009	Employee Is Killed in Fall Through Unguarded Skylight	At approximately 3:30 p.m. on July 22, 2009, Employee #1 and his supervisor were on a roof to remove bees from an air conditioning unit. The bees chased Employee #1, and he fell through an unguarded skylight located partway between the hatch and the air conditioner. He fell 25 ft striking a concrete floor and died.	5531: Auto and Home Supply Stores	1	Buildings / Structures	Fall (From Elevation)	Work-Surface/Facil.-Layout Cond.
201262862 / 315148437	2010	Employee Is Killed in Fall Through Skylight	At approximately 12:20 p.m. on December 22, 2010, Employee #1 was working at a facility of a firm that manufactured rubber and plastic hoses and belts. Employee #1 had been employed at the facility since August 10, 2010, and he had been with the corporation since July 1, 1984. Employee #1 was on the roof to investigate the origin of a water leak from a chiller. The employer had three other employees who went up onto the roof on a regular basis to check equipment and conduct other inspection checks. Employee #1 was a plant manager and would not normally have gone up to the roof to view the leaking chiller. The supervisor of maintenance, however, wanted to show Employee #1 where the leak was coming from and how they were going to fix it. The supervisor of maintenance stated that he did not see if Employee #1 slipped. He did see Employee #1 lose his balance while near the skylight and fall through. The supervisor of maintenance was the only one accompanying Employee #1 while he was on the roof. Employee #1 fell through a skylight made of an acrylic plastic dome. It was not equipped with a skylight guard or standard railing on all four sides. He fell 23 feet. Employee #1 was rushed to the hospital, but he was pronounced dead at approximately 3:00 p.m. According to the medical examiner's report, Employee #1 sustained multiple . . . traumatic injuries resulting from the fall	3052: Rubber and Plastics Hose and Belting	1	Buildings / Structures	Fall (From Elevation)	Work-Surface/Facil.-Layout Cond.

**Fatal Accidents on Walking-Working Surfaces Preventable by the Final Standards, continued
(2006-2010 OSHA IMIS)**

Accident Summary Number / Accident Inspection Number	Year	Brief Description of Accident	Abstract	SIC: Description	Number of Fatalities	Source of Injury	Event Type	Environmental Factor
202625380 / 314956145	2010	Employee Falls Through Skylight and Later Dies From Injuries	On September 11, 2010, Employee #1, a machinery maintenance worker, fell through the skylight, falling 17 feet to a concrete floor. Employee #1 was treated and transported by . . . [the fire department] to the . . . hospital. Employee #1 expired on September 27, 2010 at 3:10 p.m. as a result of the injuries received from the fall.	2068: Salted and Roasted Nuts and Seeds	1	Buildings / Structures	Fall (From Elevation)	Other
200785004 / 314178146	2010	Employee Falls Through Skylight and Is Killed	On July 31, 2010, Employee #1 was repairing roof structure leaks. He was removing metal roofing screws, applying silicone, and reinstalling metal roofing screws to the roof structure. The employee walked onto an unguarded existing skylight and fell approximately 22 ft. Employee #1 was killed as a result of the blunt force injury from the fall.	5712: Furniture Stores	1	Working Surface	Fall (From Elevation)	Work-Surface/Facil.-Layout Cond.
200644698 / 313691917	2010	Employee Is Killed in Fall Through Skylight	On May 15, 2010, Employee #1 was repairing a roof and fell through a skylight. He fell 22 feet to the concrete and was killed.	3999: Manufacturing Industries, NEC	1	Working Surface	Fall (From Elevation)	Work-Surface/Facil.-Layout Cond
Fall From Surface Due to Slip or Trip								
201488541 / 125761775	2006	Employee Dies From Accidental Overdose	On March 8, 2006, Employee #1 was found unconscious, lying on the floor in the toilet room of the store. There were no witnesses to the accident, but there was evidence that Employee #1 had slipped on a liquid, fell and struck his head. He was treated at . . . [the medical center] for a head injury, cervical strain, and thoracic strain. No permanent disability was anticipated. Employee #1 was prescribed medication for pain. He died in his sleep at approximately 4:45 p.m. the next day, from an accidental overdose of the prescribed medication.	5813: Drinking Places	1	Drugs / Alcohol	Ingestion	Other

**Fatal Accidents on Walking-Working Surfaces Preventable by the Final Standards, continued
(2006-2010 OSHA IMIS)**

Accident Summary Number / Accident Inspection Number	Year	Brief Description of Accident	Abstract	SIC: Description	Number of Fatalities	Source of Injury	Event Type	Environmental Factor
201859147 / 310576269	2007	Worker Suffers Concussion in Fall on Ice and Later Dies	At approximately 4:00 p.m. on January 30, 2007, a worker was placing a chain in front of the bay entrance to prevent customer usage. Because of cold inclement weather, he slipped and fell on the ice, hitting his head. The employee first went to a chiropractor, who recommended that the worker go to a hospital emergency room. The worker went to [the h]ospital, where he later died from a concussion.	7542: Carwashes	1	Working Surface	Fall (Same Level)	Weather, Earthquake, Etc.
202454880 / 310493713	2008	Employee Slipped and Fell on Concrete, Later Dies	At approximately 1:30 p.m. on September 22, 2008, Employee #1, a teacher at a public middle school, told her classroom aide that she was going to the restroom. Employee #1 was walking to the restroom when she apparently fell on a broken concrete walkway. Shortly thereafter, a campus security guard found Employee #1 laying on her left side on the broken concrete walkway. Employee #1 was transported to the hospital where she died on September 25, 2008, of unspecified causes.	8211: Elementary and Secondary Schools	1	Working Surface	Fall (Same Level)	Work-Surface/Facil.-Layout Cond.
201149689 / 309300846	2008	Employee Falls and Strikes Head, Later Dies	On February 27, 2008, Employee #1 was walking from one corner of the maintenance shop office towards the entrance door of the shop, approximately 10 ft away. As he walked, he stepped over a battery charging unit, automatic battery charger, Part Number 395101, Model Number 12050. An electrical cord connecting the battery charger to an electrical outlet and a cord connecting the battery charger to the floor scrubber were in place. His foot caught the cords, and he fell onto the tile floor. Employee #1 did not break his fall with his hands and struck his head and face on the floor. He was hospitalized and later died.	8211: Elementary and Secondary Schools	1	Other	Fall (Same Level)	Other
201955804 / 313588337	2009	Employee Slips and Strikes Head, Later Dies	At approximately 4:15 p.m. on July [25], [2009], Employee #1 was walking through the kitchen in a restaurant, slipped and fell on a slick floor. She struck the back of her head, was hospitalized, and died the next day.	5812: Eating Places	1	Working Surface	Fall (Same Level)	Work-Surface/Facil.-Layout Cond

**Fatal Accidents on Walking-Working Surfaces Preventable by the Final Standards, continued
(2006-2010 OSHA IMIS)**

Accident Summary Number / Accident Inspection Number	Year	Brief Description of Accident	Abstract	SIC: Description	Number of Fatalities	Source of Injury	Event Type	Environmental Factor
200033769 / 315154005	2010	Employee Is Killed in Fall on Platform	On December 16, 2010, Employee #1 was working on an exterior loading platform for tankers. He was assigned to separate cooking grease and water that was stored in a silo. While using the grease loading arm and related piping to fill an empty tanker truck with grease, Employee #1 apparently slipped, struck his head on the platform, and was killed. There were no witnesses to the accident.	2013: Sausages and Other Prepared Meats	1	Buildings / Structures	Fall (Same Level)	Work-Surface/Facil-Layout Cond
202519856 / 312577059	2010	Employee Slips and Falls on Wet Surface, Is Killed	Employee #1, an employee of a transportation company, slipped and fell on a wet slippery floor in the receiving bay of a milk-producing facility. Employee #1 hit his head on the concrete floor and sustained an acute subdural hematoma brain injury. Employee #1 was killed.	4221: Farm Product Warehousing and Storage	1	Other	Fall (Same Level)	Work-Surface/Facil-Layout Cond
200651693 / 312555451	2010	Employee Fractures Ankle in Fall, Later Dies of Blood Clot	Employee #1 slipped on a wet floor and fell at a restaurant. Prior to the incident another employee had been asked to clean up the water station at the restaurant. The station cart was moved so the corner of the carpet could be flipped up to sweep under it. A little bit of water was swept into the main aisle after which the carpet was put back in place along with the cart. The employee then continued sweeping until she heard Employee #1 fall. Employee #1 fractured her left ankle. Employee #1 died two days later from a blood clot.	5812: Eating Places	1	Water	Fall (Same Level)	Work-Surface/Facil-Layout Cond

Fall From Scaffold

**Fatal Accidents on Walking-Working Surfaces Preventable by the Final Standards, continued
(2006-2010 OSHA IMIS)**

Accident Summary Number / Accident Inspection Number	Year	Brief Description of Accident	Abstract	SIC: Description	Number of Fatalities	Source of Injury	Event Type	Environmental Factor
202464509 / 310195946	2006	Employee Dies After Fall From Scaffold	On November 16, 2006, Employee #1 was an inmate, applying drywall compound to walls of the . . . [c]onference [r]oom. He was using a rolling scaffold, with one plank at the 4-ft level. The scaffold rolled when he stepped down, causing him to lose his balance. As he fell, his foot became caught in the top bar of the scaffold, which caused him to flip over backwards and strike the back of his head on the floor. Employee #1 was treated in the . . . [e]mergency [r]oom for a blunt force head trauma injury to the back of the head, and lacerations to his hand, left elbow, and nose. He was hospitalized. . . [later] had craniotomy surgery and evacuation of a hematoma. After surgery, he remained comatose and breathing with a ventilator, until his death on November 27, 2006.	9223: Correctional Institutions	1	Bodily Motion	Fall (From Elevation)	Other
201954864 / 310384003	2006	Employee Falls From Outrigger Scaffold and Dies	At approximately 9:30 a.m. on October 9, 2006, Employee #1, a window washer, was working on an existing building and was using a rolling counter-weighted portable outrigger beam scaffold with Sky Genie descent device attached to the seat board. The outrigger beam scaffold was not adequately counter-weighted, and was not tied back. In addition, a coworker moved the scaffold horizontally while Employee #1 occupied it. The coworker moving the scaffold was adjacent to the unprotected roof edge and was not wearing fall protection. As the scaffold was moved to the elevated roof position and Employee #1 descended down to the next row of windows, the two sections of the outrigger beam separated due to the lack of a safety retaining pin. Employee #1, on the seat board, was also not attached to a life line, the locking devices in use were not self-closing and self-locking, and the available lanyard was not positive-locking. The outrigger beam separated from the roof and both the scaffold and Employee #1 fell approximately 20 ft to the ground. Employee #1 sustained unspecified fractures and died on November 11, 2006, from complications following his injuries.	7349: Building Maintenance Services, NEC	1	Machine	Fall (From Elevation)	Work-Surface/Facil.- Layout Cond.

**Fatal Accidents on Walking-Working Surfaces Preventable by the Final Standards, continued
(2006-2010 OSHA IMIS)**

Accident Summary Number / Accident Inspection Number	Year	Brief Description of Accident	Abstract	SIC: Description	Number of Fatalities	Source of Injury	Event Type	Environmental Factor
200980670 / 307815050	2006	Employee Is Killed in Fall From Scaffold	On February 14, 2006, Employee #1 was working from scaffolding that was approximately 30-feet tall. The scaffolding was directly above a drilling rig cellar that was about 10-feet deep. While Employee #1, thought to be collecting tools, was on the scaffold, he fell into the cellar, killing him. Employee #1's hard hat was found on the scaffolding directly above the cellar, with Employee #1 below. The accident investigation revealed that Employee #1 was not wearing fall protection, and the injuries found on his body were consistent with a fall from a scaffold. There were no witnesses.	1381: Drilling Oil and Gas Wells	1	Other	Fall (From Elevation)	Work-Surface/Facil.- Layout Cond.
202341905 / 311442859	2007	One Employee Is Killed, One Is Injured in Fall From Scaffold	On December 7, 2007, Employees #1 and #2 were preparing to do window washing from the roof of a 46-story building. A two-point suspended scaffold platform detached from the building's permanent window washing rig that was anchored to the roof. It slid out into position to go down, when the cables slipped from their attachment points. Employees #1 and #2 fell with the scaffold to the ground. Employees #1 was pronounced dead on the scene and Employee #2 was transported in critical condition to Cornell hospital. Employees #1 and #2 did not put on their safety harnesses or install their life lines. The life lines and harnesses, and a bucket of hot water and soap were found on the roof next to the scaffold rig. Two new cables were installed just 30 days earlier, and this was the first time the scaffold was being used after the cable installation.	7349: Building Maintenance Services, NEC	1	Buildings / Structures	Fall (From Elevation)	Work-Surface/Facil.- Layout Cond.

**Fatal Accidents on Walking-Working Surfaces Preventable by the Final Standards, continued
(2006-2010 OSHA IMIS)**

Accident Summary Number / Accident Inspection Number	Year	Brief Description of Accident	Abstract	SIC: Description	Number of Fatalities	Source of Injury	Event Type	Environmental Factor
202472106 / 311106298	2007	Employee Is Killed in Fall From Boatswain Chair	On June 15, 2007, an employee was making sure that a coworker, a new trainee, was geared up properly and that all of his equipment was properly secured. Both men were in the process of cleaning the windows of a seven story resort building. They were using a boatswain chair as the chosen form of scaffolding. As the coworker was getting ready to access his chair, the employee told him to wait and watch him to see the safest and most effective way to gain access to the chair and begin the descent down the building. The employee apparently did not check his own gear before accessing the chair. When he climbed over the parapet wall, he fell to the ground. The coworker called the emergency medical services as he went down stairs to see how the employee was doing. Once there, the coworker began cardio-pulmonary resuscitation until the help arrived. The employee was killed.	7349: Building Maintenance Services, NEC	1	Bodily Motion	Fall (From Elevation)	Other
200643831 / 310999206	2007	Employee Falls Off Scaffold, Later Dies	On June 12, 2007, Employee #1 was working on a scaffold, taking measurements, at a height of 15 feet. He fell to the concrete slab below and later died from his injuries.	5051: Metals Service Centers and Offices	1	Working Surface	Fall (From Elevation)	Work-Surface/Facil.-Layout Cond.
200624237 / 310711106	2007	Employee Dies After Fall in Church Sanctuary	On January 6, 2007, Employee #1 was using a scaffold or a ladder to reach the 25-ft high ceiling in a church sanctuary. He was either replacing ceiling tiles or repairing a light fixture. He received unspecified injuries when he fell. He was hospitalized and died on January 14, 2007.	7349: Building Maintenance Services, NEC	1	Working Surface	Fall (From Elevation)	Other

**Fatal Accidents on Walking-Working Surfaces Preventable by the Final Standards, continued
(2006-2010 OSHA IMIS)**

Accident Summary Number / Accident Inspection Number	Year	Brief Description of Accident	Abstract	SIC: Description	Number of Fatalities	Source of Injury	Event Type	Environmental Factor
200643708 / 309790806	2007	Employee Slips and Falls From Work Platform and Is Killed	Employee #1 was working on an airplane from a work platform approximately 7 ft above the ground when he apparently slipped and fell to the ground fatally striking his head. The platform had a guardrail on only three sides and the ladder side was open with no means of fall prevention. Employee #1 was killed.	9711: National Security	1	Bodily Motion	Fall (From Elevation)	Work-Surface/Facil.- Layout Cond.
201311925 / 311916837	2008	Worker Falls Off A Scaffold and Is Killed	On October 14, 2008, an employee was applying stucco to the front of a single family house while working on a 20-ft scaffold. He fell backwards off the scaffold striking his head on a concrete driveway. He suffered a concussion and was killed.	3471: Plating and Polishing	1	Other	Card-Vasc./Resp. Fail.	Other
200074391 / 314619925	2010	Employee Dies Falling From High Scaffold	Employee #1 and two coworkers were on a 25-ft scaffold, setting it up in order to perform maintenance on an aircraft. The center of the work platform was equipped with sliding floor panels, which allowed the sections of floor to open up around the tail of the aircraft. On top of the floor panels was a rolling platform the maintenance workers would stand on, while servicing the aircraft. Employee #1 and a coworker, pushed the rolling platform toward the tail of the aircraft, to put it into position, and discovered that six of the sliding floor panels directly below were open instead of closed. Subsequently, Employee #1 fell through the opening in the floor of the platform as he pushed the rolling platform forward, landing on the concrete ground below. Employee #1 passed away as a result of injuries suffered.	4581: Airports, Flying Fields, & Services	1	Working Surface	Fall (From Elevation)	Work-Surface/Facil.- Layout Cond.
201859162 / 310565171	2006	Employee Is Killed in Fall From Work Platform	On December 13, 2006, Employee #1 was working from the work platform of a stair ladder (platform ladder) that was approximately 14.9 feet from a concrete floor. While he was working, Employee #1 fell down the steps of the platform ladder and was killed.	5211: Lumber and Other Building Materials	1	Ladder	Fall (From Elevation)	Other

**Fatal Accidents on Walking-Working Surfaces Preventable by the Final Standards, continued
(2006-2010 OSHA IMIS)**

Accident Summary Number / Accident Inspection Number	Year	Brief Description of Accident	Abstract	SIC: Description	Number of Fatalities	Source of Injury	Event Type	Environmental Factor
201762903 / 311046049	2007	Employee Is Killed in Fall From Scaffolding	On May 26, 2007, Employee #1 and several other employees were scheduled to sandblast and paint the inside of a petrochemical tank that was approximately 45 feet in diameter and approximately 60 feet in height. The tank had a floating roof, which was lowered to allow installation of the scaffolding from which the men would work. Employee #1 attempted to lower himself from the scaffold using the ladder installed on the ends of the scaffolding. One witness said that the ladder broke as Employee #1 was descending and he fell approximately 20 feet to the floating roof. Attempts were made by the other employees present to render CPR, but they failed to revive Employee #1. He was pronounced dead at the scene a short time later. (Note: Employee fell from ladder, not scaffold.)	2911: Petroleum Refining	1	Ladder	Fall (From Elevation)	Other
200556223 / 314767468	2010	Employee Dies After Fall From Scaffold	At approximately 7:00 a.m. on October 8, 2010, Employee #1 was a foreman and was climbing a scaffold ladder on the south side of the exterior of the building. He was climbing to the work area on a scaffold platform at a higher level. Employee #1 was approximately 27 ft above the lower landing when a coworker heard a loud noise that was not described. The coworker called out to Employee #1 but he did not respond. Coworkers then observed Employee #1 release his grip on the ladder. Employee #1 was injured when he fell approximately 41 ft to the ground. Employee #1 died from an illness or injury that was not specified.	9999: Nonclassifiable Establishments	1	Bodily Motion	Fall(From Elevation)	Other
Fall From Stairs/Stairway/Steps								
202004685 / 308991082	2006	Employee Falls Down Stairway and Is Killed	Employee #1, a high school teacher, . . . slipped, tripped, or otherwise fell down a thirteen-step stairway and was killed. The stairway width was no greater than 44 in., but the enclosed wall side of the stairway did not have a handrail.	8211: Elementary and Secondary Schools	1	Working Surface	Fall (From Elevation)	Work-Surface/Facil.-Layout Cond.

**Fatal Accidents on Walking-Working Surfaces Preventable by the Final Standards, continued
(2006-2010 OSHA IMIS)**

Accident Summary Number / Accident Inspection Number	Year	Brief Description of Accident	Abstract	SIC: Description	Number of Fatalities	Source of Injury	Event Type	Environmental Factor
201992948 / 311240899	2007	Employee Falls, Strikes Head and Dies	On June 27, 2007, Employee #1 was walking down a stairway and tripped. He struck his head on a fixed ladder at the bottom of the stairs, and died several days later. (ORA Note: Did not fall from a ladder, slipped/tripped on stairway.)	7011: Hotels and Motels	1	Working Surface	Fall (From Elevation)	Work-Surface/Facil.- Layout Cond.

Window Cleaning

202342184 / 312497647	2008	Employee Is Killed in Fall While Window Washing	At approximately 4:30 p.m. on August 26, 2008, an employee, a self-employed window washer was performing his quarterly cleaning of the double hung windows of a co-op unit owner. He was using a positioning belt and fell from the 12 story because the seven inch anchor bolts failed. He was pronounced dead on the scene. It appears that the anchor bolts may have been inadvertently cut during a recent unit window replacement.	7349: Building Maintenance Services, NEC	1	Working Surface	Fall (From Elevation)	Other
202023644 / 311897995	2008	Employee Is Killed in Fall While Window Washing	On April 17, 2008, Employee #1, a window washer, fell 40 feet when the anchor point came apart while he was pressure washing the window landings. Employee #1 suffered fatal injuries from the fall.	7349: Building Maintenance Services, NEC	1	Buildings / Structures	Fall (From Elevation)	Other

Chimney

**Fatal Accidents on Walking-Working Surfaces Preventable by the Final Standards, continued
(2006-2010 OSHA IMIS)**

Accident Summary Number / Accident Inspection Number	Year	Brief Description of Accident	Abstract	SIC: Description	Number of Fatalities	Source of Injury	Event Type	Environmental Factor
202498119 / 311734842	2008	Employee Is Killed By Fall While Cleaning Chimney	On February 20, 2008, Employee #1 was attempting to clean a house chimney. According to the Coroner's report, Employee #1 sustained impact injuries to the head and neck. Based on the chimney sweep process and the home owner interview, Employee #1 walked across two sections of the house roof to gain access to the chimney top. Employee #1 was equipped with only one ladder to gain access to the porch roof and primary roof levels, with the final destination being the roof peak. A section of aluminum ladder was observed secured to the main roof of the house with hooks that overlapped the peak of the roof. Employee #1 had used a 12-foot section of ladder to access the porch roof from the ground. He then had to pull that section up onto the porch roof and set it up to access the ladder on the main roof. The section of ladder Employee #1 used to access the porch roof was also lying on the ground along with the cleaning equipment he had used to clean the flu. There were no witnesses to Employee #1 falling. It is not known if Employee #1 was climbing the section of ladder while accessing the main roof from the porch or if he fell while setting the ladder up to access the main roof. The minimum height Employee #1 could have fallen would be approximately 15 feet. (The ground slopped away from the end of the porch where the employee was found) The metal sloped porch roof was snow covered. Neither a personal fall arrest system nor guard rails were used. Employee #1 was working alone which was against company policy, which states that two people are required on these worksites. The home owner even told Employee #1 to come back if it was not safe. The cause of death was head and neck injuries.	7349: Building Maintenance Services, NEC	1	Ladder	Fall (From Elevation)	Work-Surface/Facil.- Layout Cond.
Other Falls								
202358974 / 310006804	22006	Employee Is Killed in Fall From Metal Deck	On July 21, 2006, Employee #1, a wireless communications technician, was walking on a metal deck that provided access to a cellular phone antenna inside of an existing church steeple. The metal deck did not have guardrails or mesh protecting the edge. He walked off of the open-sided metal deck, fell 44 feet, and landed on his head. He was pronounced dead at the scene. Employee #1 was not using a personal fall arrest system.	8748: Business Consulting, NEC	1	Buildings / Structures	Fall (From Elevation)	Work-Surface/Facil.- Layout Cond.

**Fatal Accidents on Walking-Working Surfaces Preventable by the Final Standards, continued
(2006-2010 OSHA IMIS)**

Accident Summary Number / Accident Inspection Number	Year	Brief Description of Accident	Abstract	SIC: Description	Number of Fatalities	Source of Injury	Event Type	Environmental Factor
201923836 / 308320605	2006	Employee Is Killed in Fall From Reactor	Employee #1 was working atop a plant reactor when he fell approximately 21 feet and was killed. The grates of a walking surface were removed for maintenance.	2819: Industrial Inorganic Chemicals, NEC	1	Bodily Motion	Fall (From Elevation)	Work-Surface/Facil.- Layout Cond.
200922425 / 311565048	2007	Employee Falls Through Ceiling Tile, Later Dies	On December 10, 2007, Employee #1 was removing speakers from the ten movie theaters at that location. Employee #1 was walking on the speaker platform which is located 12-ft 9-in. above the floor level in order to remove the speakers. Employee #1 apparently stepped through an opening on the platform and fell to the floor. Employee #1 was airlifted to the hospital in critical condition and died of his injuries on December 13, 2007.	7832: Motion Picture Theaters, Ex Drive-in	1	Working Surface	Fall (From Elevation)	Work-Surface/Facil.- Layout Cond.
200643781 / 310998232	2007	Employee Is Killed in Fall From Top of Tanker	Employee #1 was walking on the top of a paving maintenance supply tanker without fall protection, when he fell approximately 12 feet 6 inches to the concrete floor. He was killed.	2891: Adhesives and Sealants	1	Motor Vehicle (Indus.)	Fall (From Elevation)	Other
201613668 / 311702112	2007	Employee Is Killed in Fall in Silo	At approximately 6:15 am on December 21, 2007, Employee #1 was riding a vertical conveyor man-lift to the top of the grain silo tower. When Employee #1 reached a height of approximately 95 ft, he slipped and fell through the man-lift floor opening below. Employee #1 struck his head then landed on a cross member of the structure. Employee #1 sustained unspecified fractures and was unable to free himself. Employee #1 died at the scene.	7363: Help Supply Services	1	Buildings / Structures	Fall (From Elevation)	Work-Surface/Facil.- Layout Cond.

**Fatal Accidents on Walking-Working Surfaces Preventable by the Final Standards, continued
(2006-2010 OSHA IMIS)**

Accident Summary Number / Accident Inspection Number	Year	Brief Description of Accident	Abstract	SIC: Description	Number of Fatalities	Source of Injury	Event Type	Environmental Factor
201353331 / 310031315	2007	Employee Is Killed in Fall From Resort Balcony	On April 1, 2007, an employee was working as a maintenance worker at a hotel resort. A guest could not get into his room on the fifth floor, so the employee attempted to get into the room. The employee was not able to open the door with the room key, and he could not open the door using the black box which is a device which acts like a master key. The employee entered the adjacent room and went to the balcony. The employee intended to get into the locked room by crossing from one balcony to the balcony of the locked room. The space between the two balconies was approximately six feet. A wall air conditioning unit was between the two balconies, and it slightly protruded from the wall. The employee climbed atop the balcony wall and stepped onto the air conditioning unit. The employee slipped and fell approximately 36 feet to the concrete floor of the second level of the resort. He died at the scene from his injuries, which included skull fractures.	6531: Real Estate Agents and Managers	1	Working Surface	Fall (From Elevation)	Other
200357457 / 312453376	2008	Employee Is Killed in Fall From Catwalk	On November 17, 2008, Employee #1 and a coworker were tightening a bolt on a inclined conveyor belt approximately 50 feet high. Employee #1 was walking down the conveyor catwalk when a section of the catwalk plank gave way. He was not wearing a safety harness, and he fell approximately 38 feet to the ground. Emergency medical services were contacted, and Employee #1 was rushed to the hospital, where he was pronounced dead.	3271: Concrete Block and Brick	1	Other	Fall (From Elevation)	Work-Surface/Facil.- Layout Cond.
200902245 / 310990205	2008	Employee Falls Into Paper Machine and Is Killed	On August 15, 2008, an employee was cleaning off the After Dryer Hood on the Number 16 paper machine using compressed air. The employee had been walking on a catwalk located on top of the hood on the east side. The employee left the catwalk and walked onto the top of the hood and fell in to the machine on to the dryer belt when the panel he was standing on gave way beneath him. The employee died of the injuries he received in the fall.	2621: Paper Mills	1	Working Surface	Fall (From Elevation)	Work-Surface/Facil.- Layout Cond.

**Fatal Accidents on Walking-Working Surfaces Preventable by the Final Standards, continued
(2006-2010 OSHA IMIS)**

Accident Summary Number / Accident Inspection Number	Year	Brief Description of Accident	Abstract	SIC: Description	Number of Fatalities	Source of Injury	Event Type	Environmental Factor
200555324 / 311525745	2008	Employee Falls From Derrick and Is Killed	At approximately 1:30 p.m. on August 13, 2008, Employee #1, a derrickman, climbed a derrick of a rig to access the monkey board. This was the first time the monkey board had been accessed at this location. He was to prepare the monkey board to receive pipe that will be tripped into the hole. While securing the rear guardrail on the monkey board, the employee either tripped or slipped, which allowed the section to rotate past the point of where it was to be pinned. As it rotated, he was still holding onto the section. Employee #1 fell approximately 25 ft and was killed. The employee was not using fall protection.	1389: Oil and Gas Field Services, NEC	1	Working Surface	Fall (From Elevation)	Work-Surface/Facil.- Layout Cond.

Source: U.S. Department of Labor, OSHA, Directorate of Standards and Guidance, Office of Regulatory Analysis-Safety.

BILLING CODE 4510-29-C

VI. Federalism

OSHA has reviewed the final rule in accordance with Executive Order (E.O.) 13132 on Federalism (64 FR 43255 (8/10/1999)). This E.O. requires that Federal agencies, to the extent possible, refrain from limiting state policymaking discretion; consult with states prior to taking action that restricts state policy options; and take action that has federalism implications only where (1) there is “constitutional and statutory authority” for such action, and (2) the problem is of “national significance” (E.O. 13132, Section 3(b)).

Section 4 of E.O. 13132 allows Federal agencies to preempt state law, but only (1) where the Federal statute contains an express preemption provision or there is some other clear evidence that Congress intended preemption of state law, or (2) where the exercise of state authority conflicts with the exercise of Federal authority under the Federal statute. The E.O. further provides that Federal agencies must limit any such preemption of state law to the extent possible.

The final rule complies with E.O. 13132. The FEA (Section V) and other information in the rulemaking record shows that worker exposure to walking-working surface hazards, particularly fall hazards, is very widespread. Workers throughout general industry are exposed to walking-working surface hazards that can result in slips, trips and falls and other injuries and fatalities. According to the Bureau of Labor Statistics (BLS) data, slips, trips, and falls are a leading cause of workplace fatalities and injuries in general industry. As discussed in the Analysis of Risk section (Section II), workplace deaths due to slips, trips, and falls are second only to motor-vehicle accidents as the leading cause of worker fatalities.

Congress enacted the Occupational Safety and Health Act of 1970 (OSH Act) (29 U.S.C. 651 *et seq.*) “to assure so far as possible every working man and woman in the nation safe and healthful working conditions” (29 U.S.C. 651(b)). To achieve that objective, Congress expressly authorizes the Secretary of Labor to promulgate occupational safety and health standards applicable to businesses affecting interstate commerce (29 U.S.C. 655(a)).¹⁶⁴

¹⁶⁴ The OSH Act defines an “occupational safety and health standard” as “a standard which requires conditions, or the adoption or use of one or more practices, means, methods, operations or processes, reasonably necessary or appropriate to provide

Section 18 of the OSH Act addresses the role of states in regulating workplace safety and health issues (29 U.S.C. 667). Section 18(a) provides that the OSH Act does not prevent states from asserting jurisdiction under state law over a workplace safety and health issue with respect to which no Federal OSHA standard is in effect (29 U.S.C. 667(a)). Where Federal OSHA has regulated an occupational safety and health issue, Section 18(b) gives states the option of developing and enforcing their own occupational safety and health standards through establishment of a State Plan. Section 18(b) specifies: “Any State which, at any time, desires to assume responsibility for development and enforcement therein of occupational safety and health standards relating to any occupational safety or health issue with respect to which a Federal standard has been promulgated . . . shall submit a State plan for the development of such standards and their enforcement.”

Section 18(c) provides that the Secretary of Labor will issue approval of a State Plan if the plan provides for the development and enforcement of standards for occupational safety and health that are at least as effective in providing safe and healthful workplaces as federal OSHA standards. (29 U.S.C. 667(c)). State Plan standards may have different or additional requirements from OSHA’s standards.

Currently, 27 U.S. states and territories, including New York, have OSHA-approved State Plans. However, the New York State Plan is limited in coverage; it is one of five state and local government only State Plans (29 CFR part 1956, subpart F). As such, the New York State Plan only covers state and local government workers and does not cover private sector employers or employees.

Approximately 40 years before Congress passed the OSH Act, New York’s legislature had enacted a statute addressing the “[p]rotection of the public and of persons engaged at window cleaning and cleaning of exterior surfaces of buildings”¹⁶⁵ (N.Y.

safety and healthful employment and places of employment” (29 U.S.C. 652(8)).

¹⁶⁵ New York Lab. Law sec. 2(13) defines “public building” to include “a factory building, an office building, a mercantile building, a hotel building, a theatre building, a warehouse building, an apartment building, a state or municipal building, a school, a college or university building, a building containing a place of public assembly maintained or leased for pecuniary gain, or any other building more than one story high except a dwelling house less than three stories high or occupied by less than three families” (See also, N.Y. Comp. Codes R. & Regs. sec. 21.2(k)). Section 202 excepts the following public buildings from coverage: Multiple

Lab. Law sec. 202). Section 202 requires that workers be provided with safe means for cleaning windows and exterior surfaces, and not be required or allowed to clean any window or exterior surface unless such means are in place for the “prevention of accidents and for the protection of the public and of such persons engaged in such work” (N.Y. Lab. Law sec. 202). The statute applies to all employers whose employees clean windows and exterior surfaces of covered buildings as well as to owners, lessees, agents, and managers of such buildings.

Section 202 also authorized the Industrial Board of Appeals (Industrial Board) to “make rules to effectuate the purposes of the section.” It specifies that those rules shall be applicable exclusively throughout the state, notwithstanding any other general or local law or regulation, and that the Commissioner of Labor shall have “exclusive authority” to enforce sec. 202 and the rules issued thereunder (N.Y. Lab. Law sec. 202). Pursuant to sec. 202, the Industrial Board has issued regulations for the “protection of persons engaged at window cleaning;” however, they do not include specific provisions directed at protecting the public (N.Y. Comp. Codes R. & Regs. part 21). The regulations specify, among other things, that employees shall not be permitted to clean windows other than “in accordance with an *authorized means and methods*” (N.Y. Comp. Codes R. & Regs. sec. 21.3(b)(2) (emphasis added)). The following means and methods are the only ones the regulations authorize employers to use for cleaning windows:

- Working from safe surfaces;
- Working from window sills or ledges;
- Working from ladders;
- Working from boatswain’s chairs;
- Working from scaffolds (12 N.Y. Comp. Codes & Regs. sec. 21.4).

The authorized means and methods do not include rope descent systems (RDS)¹⁶⁶ or identify whether

dwelling six or fewer stories in height; any building three or fewer stories in height in cities, towns or villages with a population of less than 40,000; and windows or exterior surfaces of any building the Industrial Board of Appeals may exempt from the requirement.

¹⁶⁶ The final rule defines a rope descent system as a suspension system that allows an employee to descend in a controlled manner and, as needed, stop at any point during the descent. A rope descent system usually consists of a roof anchorage, support rope, a descent device, carabiner(s) or shackle(s), and a chair (seatboard). A rope descent system also is called controlled descent equipment or apparatus. Rope descent systems do not include industrial rope access systems (final § 1910.21(b)). The final rule requires that RDSs be used in

Continued

“boatswain’s chairs”¹⁶⁷ include RDSs. However, New York State Department of Labor (NYS DOL) advisory standards on practices and procedures for the use of boatswain’s chairs expressly prohibit employers from using controlled descent devices (CDDs)¹⁶⁸ for window cleaning (Advisory Standards for Construction, Operation and Maintenance of Suspended Scaffolds used for Window Cleaning and Light Maintenance, 101–1, 101–3 Design Components, sec. 9(b)(ii)).

The final rule (§ 1910.27(b)), on the other hand, allows employers to use RDSs for activities performed at elevated heights, including window cleaning. Final § 1910.27(b)(2)(i) limits the use of RDSs to elevations not exceeding 300 feet above grade; however, employers may use RDSs at greater heights if they can demonstrate that it is not feasible to access such heights by any method other than an RDS or other means pose a greater hazard than using an RDS.

OSHA received many comments on the proposed rule. Many stakeholders, including window cleaning companies and window cleaners, supported allowing employers to use RDSs, including at heights above 300 feet (*e.g.*, Exs. 138; 147; 163; 184; 221; 242; 243; 329 (1/19/2011, pgs. 326–29). Also, many stakeholders, including many New York window cleaners, opposed the proposed rule (*e.g.*, Exs. 131; 224; 311; 313; 314; 316; 319; 329 (1/19/2011; pgs. 5–8, 17–19; 354). They urged that OSHA, like New York, prohibit the use of RDSs for window cleaning and indicated concerns about the potential preemptive effect of the final rule on New York’s window cleaning laws and regulations.

conjunction with a separate personal fall arrest system to protect workers if a fall occurs (§ 1910.27(b)(2)(vi)).

¹⁶⁷ Existing § 1910.21(f)(2) defines a boatswain’s chair as a “seat supported slings attached to a suspended rope, designed to accommodate one workman in a sitting position.” OSHA’s construction cranes and derricks standard, revised in 2010, defines boatswain’s chair as “a single-point adjustable suspension scaffold consisting of a seat or sling (which may be incorporated into a full body harness) designed to support one employee in a sitting position” (29 CFR 1926.1401). In the proposed rule OSHA characterized rope descent systems as “a variation of a single-point adjustable suspension scaffold” (proposed § 1910.21(b)). Several stakeholders said OSHA’s characterization was not accurate because RDS and controlled descent devices only travel downward whereas single-point adjustable suspension scaffolds, such as boatswain’s chairs, can go up and down. (Exs. 62; 168; 205). The final rule clarifies that RDS are not a boatswain’s chair or a type of single-point adjustable suspension scaffold (final § 1910.21(b)).

¹⁶⁸ The definition of “rope descent system” (RDS) in final § 1910.21(b) states that RDS also are called CDDs.

The question of whether a state law is preempted by Federal law is one of congressional intent (*Gade v. National Solid Wastes Management*, 505 U.S. 88, 96 (1992)). In *Gade*,¹⁶⁹ a five-justice majority said the language of Section 18 of the OSH Act indicates Congress’ intent to preempt state occupational safety and health regulations relating to an issue that Federal OSHA already has regulated, unless the state has an OSHA-approved State Plan (*Id.*, at 98).

A four-justice plurality determined the state law, absent an approved State Plan, is impliedly pre-empted” (*Id.*, at 98 (Congress’ intent is “implicitly contained in the [OSH Act’s] structure and purpose”). The plurality said language in Section 18(b) requiring that a state “shall submit a State plan” for approval if it desires to assume responsibility for developing and enforcing standards on an occupational safety and health issue that Federal OSHA has regulated, evidences Congress’ intent to preempt where there is no approved plan:

The unavoidable implication of [Section 18(b)] is that a State may not enforce its own occupational safety and health standards without obtaining the Secretary’s approval (*Id.*, at 99).

The plurality noted that other parts of Section 18 also support preemption absent an approved plan (*Id.*, at 100–102). Looking at Section 18 as a whole, the plurality was persuaded that Congress sought “to promote occupational safety and health while at the same time avoiding duplicative, and possibly counterproductive, regulation” (*Id.*, at 102). Therefore, they concluded that, absent an approved plan, any state regulation of an OSHA-regulated occupational safety or health issue is preempted as being in conflict with “the full purposes and objectives” of the OSH Act. The plurality also concluded that allowing a state without a -State Plan to supplement Federal OSHA standards, even non-conflicting laws,¹⁷⁰ would be inconsistent with the “federal scheme of establishing uniform federal standards, on one hand, and

¹⁶⁹ *Gade* addressed the preemptive effect of OSHA’s Hazardous Waste Operations and Emergency Response standard (29 CFR 1910.120) on Illinois laws establishing training and license requirements for hazardous waste equipment operators and workers. Illinois did not have an approved State Plan at the time.

¹⁷⁰ OSHA notes that New York’s laws and regulations and final § 1910.27 are not non-conflicting regulations. Rather, it is “a physical impossibility” for employers and employees to comply with both the final rule, which allows the use of RDSs, and New York’s regulations, which prohibit their use (*Gade*, 505 U.S. at 98). If employers use RDSs in accordance with final § 1910.27(b) to clean windows up to 300 feet above grade, they violate New York’s regulations.

encouraging States to assume full responsibility of their own OSH programs, on the other” (*Id.*, at 103).

The Court also reached the same conclusion regarding the preemptive effect of a law that regulates public as well as workplace safety and health (*i.e.*, a “dual impact” law). The five-justice majority said that any state law “designed to promote safety and health in the workplace falls neatly within the Act’s definition of an ‘occupational safety and health standard’ ” (*Id.*, at 105). According to the Court, the fact such a state law also may have a non-occupational purpose or impact “does not render it any less of an occupational safety and health standard for purposes of preemption analysis”:

[I]t would defeat the purpose of section 18 if a state could enact measures stricter than OSHA’s and largely accomplished through regulation of worker safety and health simply by asserting a non-occupational purpose for the legislation’ (*Id.*, at 106, citing *National Solid Wastes Management Assn. v. Killian*, 918 F.2d 671, 679 (7th Cir. 1990)).

Therefore, the Court said it must look at the “effects of the law” as well legislature’s professed purpose (*Id.*, at 105). Applying this test, the Court determined that, in the absence of an approved state plan, the OSH Act preempts all state law that “constitutes, in a direct, clear and substantial way, regulation of worker health and safety” (*Id.*, at 107).¹⁷¹

Based on the following, OSHA finds that sec. 202 “directly, substantially, and specifically regulates occupational safety and health.” Although the title of sec. 202 specifies that its purpose is “[p]rotection of the public and of persons engaged at window cleaning and cleaning of exterior surfaces of buildings,” the language in sec. 202 clearly indicates it is promulgated primarily for the protection of workers rather than the public. For example, Section 202 directs employers and contractors to “provide safe means” for workers to clean windows and building surfaces and “require his employees . . . to use the equipment and safety devices” while cleaning windows and building surfaces, but does not contain any requirements directed at members of the public. As such, protection of the

¹⁷¹ OSHA notes that the Court in *Gade* recognized an exception to the OSH Act’s preemption of state regulations for “laws of general applicability” (*Gade*, 505 U.S. 107). Laws of general applicability regulate the conduct of workers “simply as members of the general public” (*Id.*). Like the Court, OSHA has consistently taken the position the OSH Act does not preempt state laws promulgated primarily for the purpose of protecting public safety, such as building, electrical and fire codes (CSP 01–03–004, The Effect of Preemption on the State Agencies without 18(b) Plans (3/13/1981)).

public appears to be a residual benefit of sec. 202's requirements to protect workers. The legislative history of sec. 202 also reinforces that it is primarily "directed at workplace safety" (*Gade*, at 107). Section 202, as originally enacted in 1930, only applied to "persons engaged at window cleaning." It wasn't until 1970 that the legislature expanded the scope of sec. 202 to cover "protection of the public."

The title of the Industrial Board regulations that implement sec. 202, "Protection of persons employed at window cleaning—structural requirements, equipment and procedure," also support that sec. 202 is primarily directed to protecting workers (N.Y. Comp. Codes R. & Regs. Part 21). The regulations' findings of fact reinforce this:

The board finds that the trade, occupation or process of cleaning the windows of public buildings involves such elements of danger to the lives, health or safety of persons employed therein as to require special regulations for the protection of such persons, in that such trade, occupation or process necessarily involves the constant hazard of falling from dangerous heights and creates a substantial risk of serious injury to such persons and others (12 N.Y. Comp. Codes & Regs. 21.0).

In addition to the "authorized means and methods" employers must use to clean windows, the regulations as well as the advisory standards also establish work practice and equipment requirements employers and workers must follow. Like OSHA standards, New York's laws and regulations establish the means and methods "reasonably necessary or appropriate to provide safety and health employment and places of employment" for workers who clean windows and exterior surfaces of public buildings.

Looking at sec. 202 and its implementing regulations and advisory standards as a whole, the substantial effect they have on workplace safety and health shows they are occupational safety and health standards within the meaning of the OSH Act. Since New York's laws regulate the same occupational safety and health issue as the final rule, pursuant to *Gade*, they can be saved from preemption only if New York has an OSHA-approved State Plan. As mentioned, New York has an approved State Plan, but it only covers state and local government employees. New York has not submitted a State Plan covering private employees for approval by the Secretary of Labor. Absent such a plan, New York's laws and regulations, to the extent that they cover private employees, are preempted as being in conflict with "the full

purposes and objectives" of the OSH Act (*Gade*, at 98). That said, New York's laws remain in effect for state and local government employees, and, to the extent that New York's laws are at least as effective as OSHA's standard, state and local government employees are prohibited from using RDS when they clean windows.

Finally, OSHA notes Congress saved two areas from federal preemption. In addition to section 18(a), discussed above, Section 4(b)(4) of the OSH Act evidences Congress' clear intent to preserve state laws that that create liability for personal injury (*Gade*, 505 U.S. at 96). Section 4(b)(4) states: "Nothing in this Act shall be construed to supersede or in any manner affect any workmen's compensation law or to enlarge or diminish of affect in any other manner, the common law or statutory rights, duties or liabilities of employers and employees under any law with respect to injuries, diseases, or death of employees arising out of, or in the course of, employment" (29 U.S.C. 653(b)(4)).

Section 202 creates a private right of action for violations of the window cleaning regulations (N.Y. Comp. Codes R. & Regs. Part 21), which the New York courts have consistently upheld (See *e.g.*, *Pollard v. Trivia Bldg. Corp.*, 291 N.Y. 19 (1943); *Bauer v. Female Academy of the Sacred Heart* (767 N.E.2d 1136 (N.Y. 2002))).

Since *Gade*, courts routinely have upheld state tort laws against preemption challenges so long as the state laws do not create conflict with an OSHA standard (See *Lindsey v. Caterpillar*, 480 F.3d. 202,212 (3d. Cir. 2007) ("We join with those courts whose holdings have formed a 'solid consensus that [Section 4(b)(4)] operates to save state tort rules from preemption'"). Explaining the rationale behind Section 4(b)(4)'s savings clause, the courts noted that the OSH Act is primarily preventive in nature and does not provide private remedies for injuries (*Irwin v. St. Joseph's Intercommunity Hospital*, 665 N.Y.S.2d 773, 778–79 (App. Div. 1997) (citing cases)).

Although Section 4(b)(4) does not protect NYSDOL's ability to enforce § 202 and the regulations implementing it, OSHA believes § 202 survives preemption to the extent that it provides workers with a private right of action for damages for injuries.

VII. State-Plan Requirements

When Federal OSHA promulgates a new standard or more stringent amendment to an existing standard, the 27 States and U.S. Territories with their

own OSHA-approved occupational safety and health plans must:

- Amend their standards to reflect the new standard or amendment; or
- Show OSHA why such action is unnecessary; for example, because an existing State standard covering this area is "at least as effective" as the new Federal standard or amendment (29 CFR 1953.5(a)).

The State standard must be at least as effective as the final Federal rule, must be applicable to both the private and public (State and local government employees) sectors, and must be completed within 6 months of the promulgation date of the final Federal rule. When OSHA promulgates a new standard or amendment that does not impose additional or more stringent requirements than an existing standard, State-Plan States are not required to amend their standards, although the Agency may encourage them to do so.

The 21 States and one U.S. Territory with OSHA-approved occupational safety and health plans covering private employers and State and local government employees are: Alaska, Arizona, California, Hawaii, Indiana, Iowa, Kentucky, Maryland, Michigan, Minnesota, Nevada, New Mexico, North Carolina, Oregon, Puerto Rico, South Carolina, Tennessee, Utah, Vermont, Virginia, Washington, and Wyoming. In addition, four States and one U.S. Territory have OSHA-approved State Plans that apply to State and local government employees only: Connecticut, Illinois, New Jersey, New York, and the Virgin Islands.

This final rule results in more stringent requirements for the work it covers. Therefore, States and Territories with OSHA-approved State Plans must adopt comparable amendments to their standards within 6 months of the date of publication of this final rule in the **Federal Register** unless they demonstrate that such amendments are not necessary because their existing standards are at least as effective in protecting workers as this final rule. Each State Plan's existing requirements will continue to be in effect until it adopts the required revisions.

VIII. Unfunded Mandates Reform Act

OSHA reviewed this final rule according to the Unfunded Mandates Reform Act of 1995 ("UMRA"; 2 U.S.C. 1501 *et seq.*) and Executive Order 13132 (64 FR 43255 (Aug. 10, 1999)). As discussed in the Final Economic Analysis and Final Regulatory Flexibility Screening Analysis, OSHA estimates that compliance with this final rule would require general industry private-sector employers to

expend about \$246.5 million each year. However, while this final rule establishes a federal mandate in the private sector, it is not a significant regulatory action within the meaning of Section 202 of the UMRA (2 U.S.C. 1532).

OSHA standards do not apply to State or local governments except in States that have elected, under a voluntary agreement, to adopt a State Plan that OSHA has approved. State Plan States enforce compliance with their State standards on public sector entities, and these agreements specify that these State standards must be equivalent to OSHA standards. Thus, although OSHA has included compliance costs for the affected public-sector entities in its analysis of the expected impacts associated with the final rule, the final rule does not involve any unfunded mandates being imposed on any State or local government entity. Consequently, this final rule does not meet the definition of a "Federal intergovernmental mandate" (see Sec. 421(5) of the UMRA (2 U.S.C. 658(5))). Therefore, for the purposes of the UMRA, the Agency certifies that this final rule does not mandate that State, local, and tribal governments adopt new, unfunded regulatory obligations.

IX. Consultation and Coordination With Indian Tribal Governments

OSHA reviewed this final rule in accordance with Executive Order 13175, (65 FR 67249 (Nov. 9, 2000)) and determined that it does not have "tribal implications" as defined in that order. The final rule does not have substantial direct effects on one or more Indian tribes, on the relationship between the Federal government and Indian tribes, or on the distribution of power and responsibilities between the Federal government and Indian tribes.

X. Office of Management and Budget Review Under the Paperwork Reduction Act of 1995

The final general industry Walking-Working Surfaces (29 CFR part 1910, subpart D) and Personal Protective Equipment (Fall Protection PPE) (29 CFR part 1910, subpart I) standards, like the proposed rule, contain collection of information (paperwork) requirements that are subject to review by the Office of Management and Budget (OMB) under the Paperwork Reduction Act of 1995 (PRA-95) (44 U.S.C. 3501 *et seq.*), and OMB regulations (5 CFR part 1320). The PRA-95 defines "collection of information" to mean, "the obtaining, causing to be obtained, soliciting, or requiring the disclosure to third parties or the public, of facts or opinions by or

for an agency, regardless of form or format" (44 U.S.C. 3502(3)(A)).

Under PRA-95, a Federal agency cannot conduct or sponsor a collection of information unless OMB approves it and the collection of information displays a currently valid OMB control number. In addition, notwithstanding any other provision of law, no employer shall be subject to penalty for failing to comply with a collection of information that does not display a currently valid OMB control number.

OSHA has OMB approval for the collection of information requirements contained in both existing subparts D and I. These Information Collection Requests (ICRs) (paperwork burden hour and cost analysis), both of which expire August 31, 2019, are titled:

- Standard on Walking-Working Surfaces (29 CFR part 1910, subpart D), OMB control number 1218-0199; and
- Personal Protective Equipment (PPE) for General Industry (29 CFR part 1910, subpart I), OMB control number 1218-0205.

In accordance with PRA-95 (44 U.S.C. 3506(c)(2)), OSHA included revised ICRs for subparts D and I in the proposed rule and solicited public comment (75 FR 28862, 29129 (5/24/2010)). OSHA also submitted the revised ICRs to OMB for review as PRA-95 requires (44 U.S.C. 3507(d)). On July 26, 2010, OMB issued a Notice of Action (NOA) for the revised subpart D ICR, filing comment on the request that did not approve the request at that time and stating: "Terms of the previous clearance remain in effect."

On October 11, 2010, OMB issued a NOA for the revised subpart I ICR, also filing comment on the proposed revisions to the ICR and stating: "OMB is not approving the collection of information in the proposed rule at this time. Prior to publication of the final rule, the agency should provide a summary of all comments related to the information collection requirements contained in the proposed rule and a description of any changes made in response to these comments." OSHA did not receive any public comments on the burden estimates in the proposed revised ICRs. However, the Agency received a number of comments on the proposed rule, discussed earlier in this preamble, that include information relevant to the paperwork analysis. OSHA addresses these comments in detail in the final ICR for subparts D and I.

Concurrent with publication of this final rule, the Department is submitting ICRs to revise the authority for the information collections under the Paperwork Reduction Act. The

Department will publish an additional **Federal Register** notice to announce the final OMB disposition on those requests.

Title: Standard on Walking—Working Surfaces (29 CFR part 1910, subpart D).

Type of Review: Revision of a currently approved collection.

OMB Control Number: 1218-0199.

Affected Public: Business or other for-profits; Federal Government; State, Local, or Tribal Government.

Total Estimated Number of Respondents: 750,000.

Total Estimated Number of Responses: 1,032,860.

Total Estimated Annual Burden Hours: 498,803.

Total Estimated Annual Cost Burden (Capital and start-up cost component): \$54,697,500.

Description of Collections of Information:

Final subpart D contains several new collection of information requirements and removes three existing collection of information requirements from this ICR.

Final § 1910.22—General requirements. Final § 1910.22(b), like the proposal, requires that employers ensure each walking-working surface can support the maximum intended load for that surface. The existing rule requires that building officials mark on plates the loads they have approved and securely affix them in a conspicuous place in the space to which they relate. The existing rule also requires that the plates not be removed or defaced and be replaced, if they are.

This final rule replaces the specifications in the existing rule (§ 1910.22(d)(1)) with performance-based language and, in so doing, deletes the collection of information requirement. In the preamble of the proposed and final rules, OSHA explained that the specification requirement in the existing rule was not necessary for two reasons: (1) Load-limit information is available in building plans and from other sources, and (2) maximum loads are taken into consideration when surfaces are designed.

Under the final rule, employers can obtain information about current walking-working surfaces from plates posted in accordance with the existing rule. For new buildings, structures and walking-working surfaces, employers can obtain information on load limits in various ways, such as from building plans, local codes, third-party certification, or self-evaluations.

Final § 1910.23—Ladders. Final § 1910.23 (b)(10) requires that any ladder with structural or other defects immediately be tagged "Dangerous: Do

Not Use,” or with “similar language in accordance with § 1910.145, and removed from service until it is repaired or replaced.” Section 1910.145 specifies that, depending on the nature of the hazard, tags must contain a “signal” word and “major message” (§ 1910.145(f)(4)). The “signal” word must be “Danger,” “Caution,” “Biological Hazard,” or “BIOHAZARD” or the tag may use the biological hazard symbol (§ 1910.145(f)(4)(i)(A)). The major message, which can be in written text, pictographs or both, must indicate “the specific hazardous condition or instruction to be communicated to the employee” (§ 1910.145(f)(4)(i)(B) and (f)(4)(iii)).

The existing rule also requires tagging defective ladders, but the requirement only applies to portable wood and metal ladders (§§ 1910.25(d)(1)(x) and 1910.26(c)(2)(vii), respectively). In addition, the subpart D ICR only takes paperwork burden hours and costs for portable metal ladders, not wood ones. This is because the existing standard for wood ladders provides the specific language that employers must use for the tags on defective ladders (“Dangerous: Do Not Use”). When OSHA supplies the exact language that employers must provide to employees, the Agency is not required to take paperwork burdens because the requirement does not come within the definition of “collection of information” under PRA-95 (5 CFR 1320.3(c)(2)).

In the proposed rule, the Agency proposed removing the word “Dangerous” from the existing tag language and requiring that tags state “Do Not Use” or similar language that complies with § 1910.145. After further analysis, however, OSHA concluded that retaining the signal word is necessary to get workers’ attention in order to provide them with basic information that a hazard exists and they must not use the ladder. OSHA did not receive any comments on proposed paragraph (b)(10).

OSHA notes that the final rule applies the tagging requirement to all ladders final § 1910.23 covers, which includes fixed ladders, mobile ladder stands and mobile ladder stand platforms in addition to portable wood and metal ladders. As a result, the final rule expands the collection of information requirement.

Section 1910.27—Scaffolds and rope descent systems. Final § 1910.27, like the proposed rule, establishes requirements for scaffolds and rope descent systems (RDS) used in general industry. The requirements are designed to protect workers whose duties require

them to work at elevations, whether on scaffolds or RDS.

Final paragraph § 1910.27(a), like the proposed rule, replaces the existing general industry scaffold standards (§§ 1910.28 and 1910.29) with the requirement that employers ensure scaffolds used meet the requirements in the construction scaffolds standards (29 CFR part 1926, subpart L). As the record indicated, many general industry employers use scaffolds to perform both general industry and construction activities. OSHA believes that allowing employers to comply with the same scaffold requirements regardless of whether they are performing general industry or construction activities will increase understanding of and compliance with the final rule, and thus, provide greater protection for workers.

By replacing the existing general industry requirements, the final rule deletes the collection of information requirement in existing § 1910.28(e)(3). That provision requires that employers ensure outrigger scaffolds are constructed and erected in accordance with table D-16, if they are not designed by a licensed professional engineer, and keep a copy of the detailed drawings and specifications at the job.

Final paragraph § 1910.27(b), like the proposal, adds new requirements that addresses the use of RDS. Final paragraphs (b)(1)(i) and (ii) contain a new collection of information requirement. Final paragraph (b)(1) requires that, before any RDS is used, the building owner must inform the employer in writing (final paragraph (b)(1)(i)), and the employer must obtain written information from the building owner (final paragraph (b)(1)(ii)), that the building owner has identified, tested, certified, and maintained each anchorage to ensure it is capable of supporting at least 5,000 pounds in any direction for each worker attached. The final rule specifies that the written information the building owner provides must be based on:

- An annual inspection; and
- A certification of each anchorage, as necessary, and at least every 10 years.

The requirement that anchorages be certified “as necessary” means the building owner must have a qualified person recertify any anchorage when the owner knows or has reason to believe recertification is needed (final paragraph (b)(1)(i)). The final rule gives building owners flexibility in determining when anchorage recertification is necessary. As discussed in Section IV, factors or conditions indicating that recertification may be needed include, but are not

limited to, an accident involving the use of an RDS; a report of damage to an anchorage, major alteration to the building; exposure of the anchorage to destructive industrial substances; and location of the building in an area that might accelerate corrosion, such as areas having exposure to high rainfall, high humidity, or sea air.

Final paragraph (b)(1)(ii) requires that employers keep the written information obtained from the building owner for the duration of the job.

OSHA believes the requirement that building owners provide written information on anchorages to employers is essential to ensure that employers know the anchorages are safe for their workers who use RDS. In addition, the requirement that employers retain the written information throughout the job is important to keep workers informed about which anchorages are safe to use. This is particularly true if the job involves multiple workshifts or work crews, the employer adds new workers during the job, or there are changes in on-site supervisors.

Final § 1910.28—Duty to have fall protection and falling object protection. Final § 1910.28 requires that employers provide protection for each employee exposed to fall and falling object hazards.

Final paragraph (b)(1)(ii) is a new requirement. The provision requires that when the employer can demonstrate that it is not feasible or creates a greater hazard to use a guardrail, safety net, or personal fall protection systems on residential roofs, the employer must develop and implement a fall protection plan that meets the requirements of 29 CFR 1926.502(k). This requirement was added to the final rule based on public comment to allow employers greater flexibility in using PPE on residential roofs and to be more consistent with OSHA’s construction’s fall protection standard.

Final paragraph (b)(8)(iii), like the proposal, is a new requirement that addresses fall hazards associated with repair, service, and assembly pits less than 10 feet deep. The provision requires that employers post readily-visible warning signs in pit areas that state “Caution—Open Pit” and also comply with the requirements in § 1910.145.

The proposed standard would have required that employers post caution signs stating “Caution—Open Floor” or a “similar legend.” In the revised ICR published in the proposed rule, OSHA said proposed § 1910.28(b)(8)(iii) contains a new collection of information requirement and took a paperwork burden. The final rule, however, does

not permit employers to post signs that contain a “similar legend;” it requires that employers must post signs that state “Caution—Open Floor.” Therefore, OSHA is not taking paperwork burden hours or costs because, as mentioned, information supplied by the Federal government to the recipient for the purpose of disclosure to the public is not a collection of information under PRA–95.

Title: Personal Protective Equipment (PPE) for General Industry (29 CFR part 1910, subpart I).

Type of Review: Revision of a currently approved collection.

OMB Control Number: 1218–0205.

Affected Public: Business or other for-profits; Federal Government; State, Local, or Tribal Government.

Total Estimated Number of Respondents: 3,500,000.

Total Estimated Number of Responses: 2,220,281.

Total Estimated Annual Burden Hours: 3,745,218.

Total Estimated Annual Cost Burden (Capital and start-up cost component): \$0.

Description of Collections of Information:

Final § 1910.140, like the proposed rule, adds a new section to subpart I that addresses personal fall protection systems, such as personal fall arrest systems, travel restraint systems and positioning systems. Although final § 1910.140 does not contain any collection of information requirements, employers whose workers use a personal fall protection system also must comply with § 1910.132. Section 1910.132(d)(2) requires employers certify in writing they have performed the required workplace hazard assessment (§ 1910.132(d)(1)) to

determine whether fall or falling-object hazards are present, or likely to be present, that make the use of personal fall protection systems necessary. The written certification must identify the date and workplace assessed and the person who is certifying that the hazard assessment was performed. In addition, the written document must identify that it is a workplace hazard assessment certification. The written certification requirement is a collection of information under PRA–95.

At the time OSHA published the proposed rule, general industry employers also were required to comply with § 1910.132(f)(4). That provision required employers to certify in writing that each worker has received and understood the PPE training. The standard also required that the written certification specify name of each employee trained plus the date and content of the training. In the revised ICR that OSHA published in the proposed rule, the Agency said § 1910.132(f)(4) imposes a new information collection requirement for personal fall protection systems and took a paperwork burden. Thereafter, as part of the Standards Improvement Project—Phase III final rule, OSHA deleted § 1910.132(f)(4) (76 FR 33590, 6/8/3011). Therefore, OSHA has removed the information collection requirement from the final ICR for Personal Protective Equipment (PPE) for General Industry.

XI. Dates

Effective Date. The final rule generally becomes effective and enforceable 60 days after publication of this document in the **Federal Register**, which is January 17, 2017. Information

collections subject to OMB approval will take effect on the date OMB approves the Department’s request to revise the information collection authority under PRA–95 or the date the rule otherwise becomes effective and the compliance date has arrived, whichever date is later. The Department will publish a document in the **Federal Register** to announce OMB’s disposition of the Department’s requests to revise the Paperwork Reduction Act authority for the information collections.

Compliance Dates. Most of the requirements in the final rule are existing provisions that OSHA is retaining and updating. OSHA believes that employers already are in compliance with those provisions and, therefore, it is not necessary to give additional time to comply with them.

However, for some of the new requirements in the final rule, OSHA is providing employers with additional time to come into compliance. The extended compliance dates give employers time to get familiar with the new requirements, evaluate changes they may need to make, purchase equipment necessary to comply with the final rule, and develop and present required training. In addition, the extended compliance dates allows employers to upgrade their fall protection systems as part of the normal “business cycle” or “useful life” of equipment (*i.e.*, cage, well, fixed ladder), which reduces compliance costs.

The following table specifies the amount of additional time OSHA is giving employers to certify anchorages, equip fixed ladders with fall protection, and train workers:

Final Subpart D Section and Requirement	Compliance Date
§1910.27(b)(1) – Certification of anchorages	November 20, 2017
§1910.28(b)(9)(i)(A) – Deadline by which employers must equip existing fixed ladders with a cage, well, ladder safety system, or personal fall arrest system	November 19, 2018
§1910.28(b)(9)(i)(B) – Deadline by which employers must begin equipping new fixed ladders with a ladder safety system or personal fall arrest system	November 19, 2018
§1910.28(b)(9)(i)(D) – Deadline by which all fixed ladders must be equipped with a ladder safety system or personal fall arrest system	November 18, 2036
§1910.30(a) and (b) – Deadline by which employers must train employees on fall and equipment hazards	May 17, 2017

For additional information about these compliance deadlines, see discussion of §§ 1910.27(b)(1), 1910.28(b)(9), and 1910.30 in Section IV.

List of Subjects in 29 CFR Part 1910

Falls, Fall arrest, Fall protection, Fall restraint, Guardrails, Incorporation by reference, Ladders, Occupational safety and health, Scaffolds, Stairs, Walking-working surfaces.

Authority and Signature

This document was prepared under the direction of David Michaels, Assistant Secretary of Labor for Occupational Safety and Health. This action is taken pursuant to sections 29 U.S.C. 653, 655, 657; Secretary of Labor's Order No. 1–2012 (77 FR 3912 (1/25/2012)); and 29 CFR part 1911.

Signed at Washington, DC, on October 4, 2016.

David Michaels,

Assistant Secretary of Labor for Occupational Safety and Health.

Final Regulatory Text

For the reasons set forth in the preamble, OSHA amends part 1910 of title 29 of the Code of Federal Regulations as follows:

PART 1910—OCCUPATIONAL SAFETY AND HEALTH STANDARDS

■ 1. The authority citation for part 1910 continues to read as follows:

Authority: 29 U.S.C. 653, 655, 657; Secretary of Labor's Order Numbers 12–71 (36 FR 8754), 8–76 (41 FR 25059), 9–83 (48 FR 35736), 1–90 (55 FR 9033), 6–96 (62 FR 111), 3–2000 (65 FR 50017), 5–2002 (67 FR 65008), 5–2007 (72 FR 31159), 4–2010 (75 FR 55355), or 1–2012 (77 FR 3912), as applicable.

Sections 1910.6, 1910.7, 1910.8 and 1910.9 also issued under 29 CFR 1911. Section 1910.7(f) also issued under 31 U.S.C. 9701, 29 U.S.C. 9a, 5 U.S.C. 553; Public Law 106–113 (113 Stat. 1501A–222); Pub. L. 11–8 and 111–317; and OMB Circular A–25 (dated July 8, 1993) (58 FR 38142, July 15, 1993).

§ 1910.6 [Amended]

■ 2. Amend § 1910.6 by:

■ a. In paragraph (e)(9), removing “1910.68(b)(12)” and “1910.179(c)(2);”; and

■ b. Removing and reserving paragraphs (h)(8) and (j)(1).

■ 3. Revise subpart D to read as follows:

Subpart D—Walking-Working Surfaces

Sec.

1910.21 Scope and definitions.

1910.22 General requirements.

1910.23 Ladders.

1910.24 Step bolts and manhole steps.

1910.25 Stairways.

1910.26 Dockboards.

1910.27 Scaffolds and rope descent systems.

1910.28 Duty to have fall protection and falling object protection.

1910.29 Fall protection systems and falling object protection—criteria and practices.

1910.30 Training requirements.

Authority: 29 U.S.C. 653, 655, and 657; Secretary of Labor's Order No. 12–71 (36 FR 8754), 8–76 (41 FR 25059), 9–83 (48 FR 35736), 1–90 (55 FR 9033), and 1–2012 (77 FR 3912), as applicable; and 29 CFR part 1911.

§ 1910.21 Scope and definitions.

(a) *Scope.* This subpart applies to all general industry workplaces. It covers all walking-working surfaces unless specifically excluded by an individual section of this subpart.

(b) *Definitions.* The following definitions apply in this subpart:

Alternating tread-type stair means a type of stairway consisting of a series of treads that usually are attached to a center support in an alternating manner such that an employee typically does not have both feet on the same level while using the stairway.

Anchorage means a secure point of attachment for equipment such as lifelines, lanyards, deceleration devices, and rope descent systems.

Authorized means an employee who the employer assigns to perform a specific type of duty, or allows in a specific location or area.

Cage means an enclosure mounted on the side rails of a fixed ladder or fastened to a structure behind the fixed ladder that is designed to surround the climbing space of the ladder. A cage also is called a “cage guard” or “basket guard.”

Carrier means the track of a ladder safety system that consists of a flexible cable or rigid rail attached to the fixed ladder or immediately adjacent to it.

Combination ladder means a portable ladder that can be used as a stepladder, extension ladder, trestle ladder, or stairway ladder. The components of a combination ladder also may be used separately as a single ladder.

Dangerous equipment means equipment, such as vats, tanks, electrical equipment, machinery, equipment or machinery with protruding parts, or other similar units, that, because of their function or form, may harm an employee who falls into or onto the equipment.

Designated area means a distinct portion of a walking-working surface delineated by a warning line in which employees may perform work without additional fall protection.

Dockboard means a portable or fixed device that spans a gap or compensates

for a difference in elevation between a loading platform and a transport vehicle. Dockboards include, but are not limited to, bridge plates, dock plates, and dock levelers.

Equivalent means alternative designs, equipment, materials, or methods, that the employer can demonstrate will provide an equal or greater degree of safety for employees compared to the designs, equipment, materials, or methods specified in this subpart.

Extension ladder means a non-self-supporting portable ladder that is adjustable in length.

Failure means a load refusal, breakage, or separation of component parts. A load refusal is the point at which the ultimate strength of a component or object is exceeded.

Fall hazard means any condition on a walking-working surface that exposes an employee to a risk of harm from a fall on the same level or to a lower level.

Fall protection means any equipment, device, or system that prevents an employee from falling from an elevation or mitigates the effect of such a fall.

Fixed ladder means a ladder with rails or individual rungs that is permanently attached to a structure, building, or equipment. Fixed ladders include individual-rung ladders, but not ship stairs, step bolts, or manhole steps.

Grab bar means an individual horizontal or vertical handhold installed to provide access above the height of the ladder.

Guardrail system means a barrier erected along an unprotected or exposed side, edge, or other area of a walking-working surface to prevent employees from falling to a lower level.

Handrail means a rail used to provide employees with a handhold for support.

Hoist area means any elevated access opening to a walking-working surface through which equipment or materials are loaded or received.

Hole means a gap or open space in a floor, roof, horizontal walking-working surface, or similar surface that is at least 2 inches (5 cm) in its least dimension.

Individual-rung ladder means a ladder that has rungs individually attached to a building or structure. An individual-rung ladder does not include manhole steps.

Ladder means a device with rungs, steps, or cleats used to gain access to a different elevation.

Ladder safety system means a system designed to eliminate or reduce the possibility of falling from a ladder. A ladder safety system usually consists of a carrier, safety sleeve, lanyard, connectors, and body harness. Cages and wells are not ladder safety systems.

Low-slope roof means a roof that has a slope less than or equal to a ratio of 4 in 12 (vertical to horizontal).

Lower level means a surface or area to which an employee could fall. Such surfaces or areas include, but are not limited to, ground levels, floors, roofs, ramps, runways, excavations, pits, tanks, materials, water, equipment, and similar surfaces and structures, or portions thereof.

Manhole steps means steps that are individually attached to, or set into, the wall of a manhole structure.

Maximum intended load means the total load (weight and force) of all employees, equipment, vehicles, tools, materials, and other loads the employer reasonably anticipates to be applied to a walking-working surface at any one time.

Mobile means manually propelled or moveable.

Mobile ladder stand (ladder stand) means a mobile, fixed-height, self-supporting ladder that usually consists of wheels or casters on a rigid base and steps leading to a top step. A mobile ladder stand also may have handrails and is designed for use by one employee at a time.

Mobile ladder stand platform means a mobile, fixed-height, self-supporting unit having one or more standing platforms that are provided with means of access or egress.

Open riser means the gap or space between treads of stairways that do not have upright or inclined members (risers).

Opening means a gap or open space in a wall, partition, vertical walking-working surface, or similar surface that is at least 30 inches (76 cm) high and at least 18 inches (46 cm) wide, through which an employee can fall to a lower level.

Personal fall arrest system means a system used to arrest an employee in a fall from a walking-working surface. It consists of a body harness, anchorage, and connector. The means of connection may include a lanyard, deceleration device, lifeline, or a suitable combination of these.

Personal fall protection system means a system (including all components) an employer uses to provide protection from falling or to safely arrest an employee's fall if one occurs. Examples of personal fall protection systems include personal fall arrest systems, positioning systems, and travel restraint systems.

Platform means a walking-working surface that is elevated above the surrounding area.

Portable ladder means a ladder that can readily be moved or carried, and

usually consists of side rails joined at intervals by steps, rungs, or cleats.

Positioning system (work-positioning system) means a system of equipment and connectors that, when used with a body harness or body belt, allows an employee to be supported on an elevated vertical surface, such as a wall or window sill, and work with both hands free. Positioning systems also are called "positioning system devices" and "work-positioning equipment."

Qualified describes a person who, by possession of a recognized degree, certificate, or professional standing, or who by extensive knowledge, training, and experience has successfully demonstrated the ability to solve or resolve problems relating to the subject matter, the work, or the project.

Ramp means an inclined walking-working surface used to access another level.

Riser means the upright (vertical) or inclined member of a stair that is located at the back of a stair tread or platform and connects close to the front edge of the next higher tread, platform, or landing.

Rope descent system means a suspension system that allows an employee to descend in a controlled manner and, as needed, stop at any point during the descent. A rope descent system usually consists of a roof anchorage, support rope, a descent device, carabiner(s) or shackle(s), and a chair (seatboard). A rope descent system also is called controlled descent equipment or apparatus. Rope descent systems do not include industrial rope access systems.

Rung, step, or cleat means the cross-piece of a ladder on which an employee steps to climb up and down.

Runway means an elevated walking-working surface, such as a catwalk, a foot walk along shafting, or an elevated walkway between buildings.

Scaffold means any temporary elevated or suspended platform and its supporting structure, including anchorage points, used to support employees, equipment, materials, and other items. For purposes of this subpart, a scaffold does not include a crane-suspended or derrick-suspended personnel platform or a rope descent system.

Ship stair (ship ladder) means a stairway that is equipped with treads, stair rails, and open risers, and has a slope that is between 50 and 70 degrees from the horizontal.

Side-step ladder means a type of fixed ladder that requires an employee to step sideways from it in order to reach a walking-working surface, such as a landing.

Spiral stairs means a series of treads attached to a vertical pole in a winding fashion, usually within a cylindrical space.

Stair rail or stair rail system means a barrier erected along the exposed or open side of stairways to prevent employees from falling to a lower level.

Stairway (stairs) means risers and treads that connect one level with another, and includes any landings and platforms in between those levels. Stairways include standard, spiral, alternating tread-type, and ship stairs.

Standard stairs means a fixed or permanently installed stairway. Ship, spiral, and alternating tread-type stairs are not considered standard stairs.

Step bolt (pole step) means a bolt or rung attached at intervals along a structural member used for foot placement and as a handhold when climbing or standing.

Stepladder means a self-supporting, portable ladder that has a fixed height, flat steps, and a hinged back.

Stepstool means a self-supporting, portable ladder that has flat steps and side rails. For purposes of the final rule, stepstool includes only those ladders that have a fixed height, do not have a pail shelf, and do not exceed 32 inches (81 cm) in overall height to the top cap, although side rails may extend above the top cap. A stepstool is designed so an employee can climb and stand on all of the steps and the top cap.

Through ladder means a type of fixed ladder that allows the employee to step through the side rails at the top of the ladder to reach a walking-working surface, such as a landing.

Tieback means an attachment between an anchorage (e.g., structural member) and a supporting device (e.g., parapet clamp or cornice hook).

Toeboard means a low protective barrier that is designed to prevent materials, tools, and equipment from falling to a lower level, and protect employees from falling.

Travel restraint system means a combination of an anchorage, anchorage connector, lanyard (or other means of connection), and body support that an employer uses to eliminate the possibility of an employee going over the edge of a walking-working surface.

Tread means a horizontal member of a stair or stairway, but does not include landings or platforms.

Unprotected sides and edges mean any side or edge of a walking-working surface (except at entrances and other points of access) where there is no wall, guardrail system, or stair rail system to protect an employee from falling to a lower level.

Walking-working surface means any horizontal or vertical surface on or through which an employee walks, works, or gains access to a work area or workplace location.

Warning line means a barrier erected to warn employees that they are approaching an unprotected side or edge, and which designates an area in which work may take place without the use of other means of fall protection.

Well means a permanent, complete enclosure around a fixed ladder.

§ 1910.22 General requirements.

(a) *Surface conditions.* The employer must ensure:

(1) All places of employment, passageways, storerooms, service rooms, and walking-working surfaces are kept in a clean, orderly, and sanitary condition.

(2) The floor of each workroom is maintained in a clean and, to the extent feasible, in a dry condition. When wet processes are used, drainage must be maintained and, to the extent feasible, dry standing places, such as false floors, platforms, and mats must be provided.

(3) Walking-working surfaces are maintained free of hazards such as sharp or protruding objects, loose boards, corrosion, leaks, spills, snow, and ice.

(b) *Loads.* The employer must ensure that each walking-working surface can support the maximum intended load for that surface.

(c) *Access and egress.* The employer must provide, and ensure each employee uses, a safe means of access and egress to and from walking-working surfaces.

(d) *Inspection, maintenance, and repair.* The employer must ensure:

(1) Walking-working surfaces are inspected, regularly and as necessary, and maintained in a safe condition;

(2) Hazardous conditions on walking-working surfaces are corrected or repaired before an employee uses the walking-working surface again. If the correction or repair cannot be made immediately, the hazard must be guarded to prevent employees from using the walking-working surface until the hazard is corrected or repaired; and

(3) When any correction or repair involves the structural integrity of the walking-working surface, a qualified person performs or supervises the correction or repair.

§ 1910.23 Ladders.

(a) *Application.* The employer must ensure that each ladder used meets the requirements of this section. This section covers all ladders, except when the ladder is:

(1) Used in emergency operations such as firefighting, rescue, and tactical law enforcement operations, or training for these operations; or

(2) Designed into or is an integral part of machines or equipment.

(b) *General requirements for all ladders.* The employer must ensure:

(1) Ladder rungs, steps, and cleats are parallel, level, and uniformly spaced when the ladder is in position for use;

(2) Ladder rungs, steps, and cleats are spaced not less than 10 inches (25 cm) and not more than 14 inches (36 cm) apart, as measured between the centerlines of the rungs, cleats, and steps, except that:

(i) Ladder rungs and steps in elevator shafts must be spaced not less than 6 inches (15 cm) apart and not more than 16.5 inches (42 cm) apart, as measured along the ladder side rails; and

(ii) Fixed ladder rungs and steps on telecommunication towers must be spaced not more than 18 inches (46 cm) apart, measured between the centerlines of the rungs or steps;

(3) Steps on stepstools are spaced not less than 8 inches (20 cm) apart and not more than 12 inches (30 cm) apart, as measured between the centerlines of the steps;

(4) Ladder rungs, steps, and cleats have a minimum clear width of 11.5 inches (29 cm) on portable ladders and 16 inches (41 cm) (measured before installation of ladder safety systems) for fixed ladders, except that:

(i) The minimum clear width does not apply to ladders with narrow rungs that are not designed to be stepped on, such as those located on the tapered end of orchard ladders and similar ladders;

(ii) Rungs and steps of manhole entry ladders that are supported by the manhole opening must have a minimum clear width of 9 inches (23 cm);

(iii) Rungs and steps on rolling ladders used in telecommunication centers must have a minimum clear width of 8 inches (20 cm); and

(iv) Stepstools have a minimum clear width of 10.5 inches (26.7 cm);

(5) Wooden ladders are not coated with any material that may obscure structural defects;

(6) Metal ladders are made with corrosion-resistant material or protected against corrosion;

(7) Ladder surfaces are free of puncture and laceration hazards;

(8) Ladders are used only for the purposes for which they were designed;

(9) Ladders are inspected before initial use in each work shift, and more frequently as necessary, to identify any visible defects that could cause employee injury;

(10) Any ladder with structural or other defects is immediately tagged

“Dangerous: Do Not Use” or with similar language in accordance with § 1910.145 and removed from service until repaired in accordance with § 1910.22(d), or replaced;

(11) Each employee faces the ladder when climbing up or down it;

(12) Each employee uses at least one hand to grasp the ladder when climbing up and down it; and

(13) No employee carries any object or load that could cause the employee to lose balance and fall while climbing up or down the ladder.

(c) *Portable ladders.* The employer must ensure:

(1) Rungs and steps of portable metal ladders are corrugated, knurled, dimpled, coated with skid-resistant material, or otherwise treated to minimize the possibility of slipping;

(2) Each stepladder or combination ladder used in a stepladder mode is equipped with a metal spreader or locking device that securely holds the front and back sections in an open position while the ladder is in use;

(3) Ladders are not loaded beyond the maximum intended load;

Note to paragraph (c)(3): The maximum intended load, as defined in § 1910.21(b), includes the total load (weight and force) of the employee and all tools, equipment, and materials being carried.

(4) Ladders are used only on stable and level surfaces unless they are secured or stabilized to prevent accidental displacement;

(5) No portable single rail ladders are used;

(6) No ladder is moved, shifted, or extended while an employee is on it;

(7) Ladders placed in locations such as passageways, doorways, or driveways where they can be displaced by other activities or traffic:

(i) Are secured to prevent accidental displacement; or

(ii) Are guarded by a temporary barricade, such as a row of traffic cones or caution tape, to keep the activities or traffic away from the ladder;

(8) The cap (if equipped) and top step of a stepladder are not used as steps;

(9) Portable ladders used on slippery surfaces are secured and stabilized;

(10) The top of a non-self-supporting ladder is placed so that both side rails are supported, unless the ladder is equipped with a single support attachment;

(11) Portable ladders used to gain access to an upper landing surface have side rails that extend at least 3 feet (0.9 m) above the upper landing surface (see Figure D–1 of this section);

(12) Ladders and ladder sections are not tied or fastened together to provide

added length unless they are specifically designed for such use;

(13) Ladders are not placed on boxes, barrels, or other unstable bases to obtain additional height.

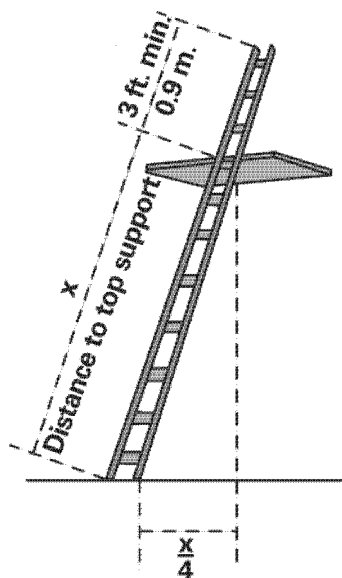

Figure D-1 -- Portable Ladder Set-up

(d) *Fixed ladders.* The employer must ensure:

(1) Fixed ladders are capable of supporting their maximum intended load;

(2) The minimum perpendicular distance from the centerline of the steps or rungs, or grab bars, or both, to the nearest permanent object in back of the ladder is 7 inches (18 cm), except for elevator pit ladders, which have a minimum perpendicular distance of 4.5 inches (11 cm);

(3) Grab bars do not protrude on the climbing side beyond the rungs of the ladder that they serve;

(4) The side rails of through or side-step ladders extend 42 inches (1.1 m) above the top of the access level or landing platform served by the ladder. For parapet ladders, the access level is:

(i) The roof, if the parapet is cut to permit passage through the parapet; or
(ii) The top of the parapet, if the parapet is continuous;

(5) For through ladders, the steps or rungs are omitted from the extensions, and the side rails are flared to provide not less than 24 inches (61 cm) and not more than 30 inches (76 cm) of clearance. When a ladder safety system

is provided, the maximum clearance must not exceed 36 inches (91 cm);

(6) For side-step ladders, the side rails, rungs, and steps must be continuous in the extension (see Figure D-2 of this section);

(7) Grab bars extend 42 inches (1.1 m) above the access level or landing platforms served by the ladder;

(8) The minimum size (cross-section) of grab bars is the same size as the rungs of the ladder.

(9) When a fixed ladder terminates at a hatch (see Figure D-3 of this section), the hatch cover:

(i) Opens with sufficient clearance to provide easy access to or from the ladder; and

(ii) Opens at least 70 degrees from horizontal if the hatch is counterbalanced;

(10) Individual-rung ladders are constructed to prevent the employee's feet from sliding off the ends of the rungs (see Figure D-4 of this section);

(11) Fixed ladders having a pitch greater than 90 degrees from the horizontal are not used;

(12) The step-across distance from the centerline of the rungs or steps is:

(i) For through ladders, not less than 7 inches (18 cm) and not more than 12 inches (30 cm) to the nearest edge of the structure, building, or equipment accessed from the ladders;

(ii) For side-step ladders, not less than 15 inches (38 cm) and not more than 20 inches (51 cm) to the access points of the platform edge;

(13) Fixed ladders that do not have cages or wells have:

(i) A clear width of at least 15 inches (38 cm) on each side of the ladder centerline to the nearest permanent object; and

(ii) A minimum perpendicular distance of 30 inches (76 cm) from the centerline of the steps or rungs to the nearest object on the climbing side. When unavoidable obstructions are encountered, the minimum clearance at the obstruction may be reduced to 24 inches (61 cm), provided deflector plates are installed (see Figure D-5 of this section).

Note to paragraph (d): Section 1910.28 establishes the employer's duty to provide fall protection for employees on fixed ladders, and § 1910.29 specifies the criteria for fall protection systems for fixed ladders.

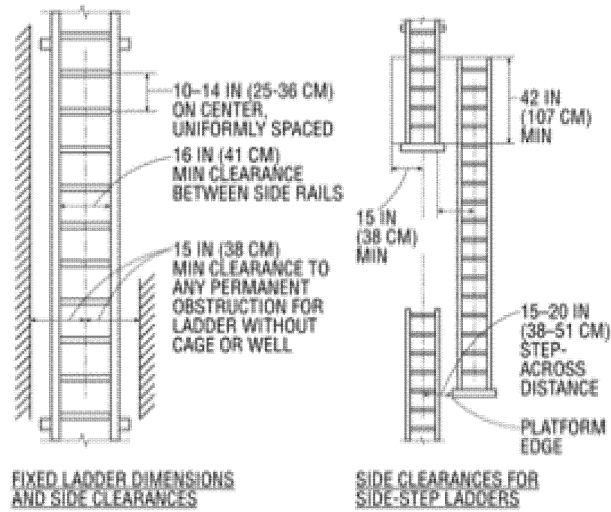

Figure D-2 -- Side-Step Fixed Ladder Sections

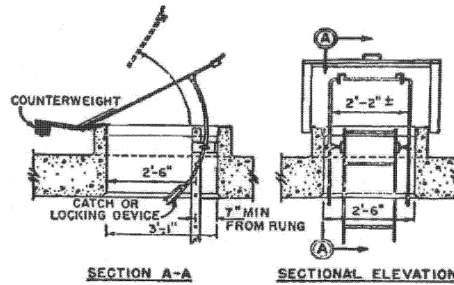

Figure D-3 – Example of Counterbalanced Hatch Cover at Roof

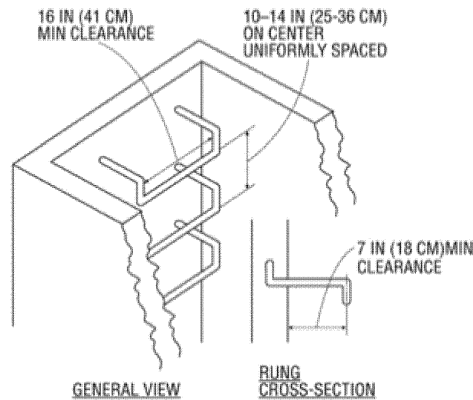

Figure D-4 -- Individual Rung Ladder

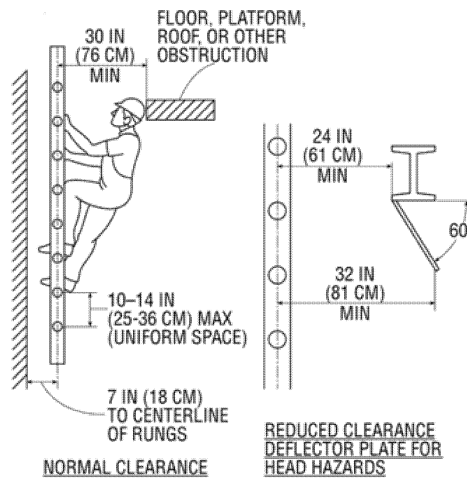

Figure D-5 -- Fixed Ladder Clearances

(e) *Mobile ladder stands and mobile ladder stand platforms*—(1) *General requirements*. The employer must ensure:

(i) Mobile ladder stands and platforms have a step width of at least 16 inches (41 cm);

(ii) The steps and platforms of mobile ladder stands and platforms are slip resistant. Slip-resistant surfaces must be either an integral part of the design and construction of the mobile ladder stand and platform, or provided as a secondary process or operation, such as dimpling, knurling, shotblasting, coating, spraying, or applying durable slip-resistant tapes;

(iii) Mobile ladder stands and platforms are capable of supporting at least four times their maximum intended load;

(iv) Wheels or casters under load are capable of supporting their proportional share of four times the maximum intended load, plus their proportional share of the unit's weight;

(v) Unless otherwise specified in this section, mobile ladder stands and platforms with a top step height of 4 feet (1.2 m) or above have handrails with a vertical height of 29.5 inches (75 cm) to 37 inches (94 cm), measured from the front edge of a step. Removable gates or non-rigid members, such as chains, may be used instead of handrails in special-use applications;

(vi) The maximum work-surface height of mobile ladder stands and platforms does not exceed four times the shortest base dimension, without additional support. For greater heights, outriggers, counterweights, or comparable means that stabilize the mobile ladder stands and platforms and prevent overturning must be used;

(vii) Mobile ladder stands and platforms that have wheels or casters are equipped with a system to impede horizontal movement when an employee is on the stand or platform; and

(viii) No mobile ladder stand or platform moves when an employee is on it.

(2) *Design requirements for mobile ladder stands*. The employer must ensure:

(i) Steps are uniformly spaced and arranged, with a rise of not more than 10 inches (25 cm) and a depth of not less than 7 inches (18 cm). The slope of the step stringer to which the steps are attached must not be more than 60 degrees, measured from the horizontal;

(ii) Mobile ladder stands with a top step height above 10 feet (3 m) have the top step protected on three sides by a handrail with a vertical height of at least 36 inches (91 cm); and top steps that are 20 inches (51 cm) or more, front to back, have a midrail and toeboard. Removable gates or non-rigid members, such as chains, may be used instead of handrails in special-use applications; and

(iii) The standing area of mobile ladder stands is within the base frame.

(3) *Design requirements for mobile ladder stand platforms*. The employer must ensure:

(i) Steps of mobile ladder stand platforms meet the requirements of paragraph (e)(2)(i) of this section. When the employer demonstrates that the requirement is not feasible, steeper slopes or vertical rung ladders may be used, provided the units are stabilized to prevent overturning;

(ii) Mobile ladder stand platforms with a platform height of 4 to 10 feet (1.2 m to 3 m) have, in the platform area, handrails with a vertical height of

at least 36 inches (91 cm) and midrails; and

(iii) All ladder stand platforms with a platform height above 10 feet (3 m) have guardrails and toeboards on the exposed sides and ends of the platform.

(iv) Removable gates or non-rigid members, such as chains, may be used on mobile ladder stand platforms instead of handrails and guardrails in special-use applications.

§ 1910.24 Step bolts and manhole steps.

(a) *Step bolts*. The employer must ensure:

(1) Each step bolt installed on or after January 17, 2017 in an environment where corrosion may occur is constructed of, or coated with, material that protects against corrosion;

(2) Each step bolt is designed, constructed, and maintained to prevent the employee's foot from slipping off the end of the step bolt;

(3) Step bolts are uniformly spaced at a vertical distance of not less than 12 inches (30 cm) and not more than 18 inches (46 cm) apart, measured center to center (see Figure D-6 of this section). The spacing from the entry and exit surface to the first step bolt may differ from the spacing between the other step bolts;

(4) Each step bolt has a minimum clear width of 4.5 inches (11 cm);

(5) The minimum perpendicular distance between the centerline of each step bolt to the nearest permanent object in back of the step bolt is 7 inches (18 cm). When the employer demonstrates that an obstruction cannot be avoided, the distance must be at least 4.5 inches (11 cm);

(6) Each step bolt installed before January 17, 2017 is capable of supporting its maximum intended load;

(7) Each step bolt installed on or after January 17, 2017 is capable of supporting at least four times its maximum intended load;

(8) Each step bolt is inspected at the start of the work shift and maintained in accordance with § 1910.22; and

(9) Any step bolt that is bent more than 15 degrees from the perpendicular

in any direction is removed and replaced with a step bolt that meets the requirements of this section before an employee uses it.

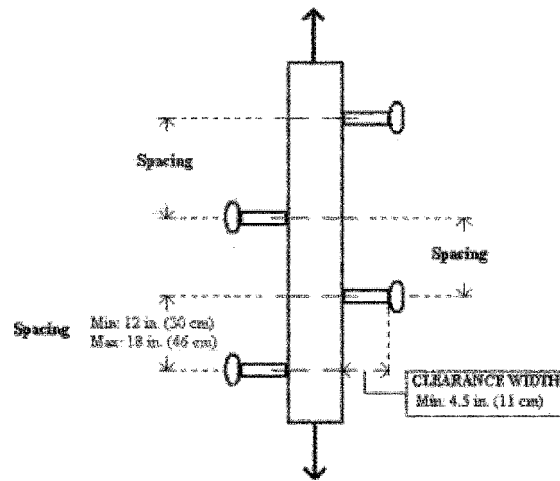

Figure D-6 -- Step Bolt Spacing

(b) *Manhole steps.* (1) The employer must ensure that each manhole step is capable of supporting its maximum intended load.

(2) The employer must ensure that each manhole step installed on or after January 17, 2017:

(i) Has a corrugated, knurled, dimpled, or other surface that minimizes the possibility of an employee slipping;

(ii) Is constructed of, or coated with, material that protects against corrosion if the manhole step is located in an environment where corrosion may occur;

(iii) Has a minimum clear step width of 10 inches (25 cm);

(iv) Is uniformly spaced at a vertical distance not more than 16 inches (41 cm) apart, measured center to center between steps. The spacing from the entry and exit surface to the first manhole step may differ from the spacing between the other steps.

(v) Has a minimum perpendicular distance between the centerline of the manhole step to the nearest permanent object in back of the step of at least 4.5 inches (11 cm); and

(vi) Is designed, constructed, and maintained to prevent the employee's foot from slipping or sliding off the end.

(3) The employer must ensure that each manhole step is inspected at the start of the work shift and maintained in accordance with § 1910.22.

§ 1910.25 Stairways.

(a) *Application.* This section covers all stairways (including standard, spiral, ship, and alternating tread-type stairs), except for stairs serving floating roof tanks, stairs on scaffolds, stairs designed into machines or equipment, and stairs on self-propelled motorized equipment.

(b) *General requirements.* The employer must ensure:

(1) Handrails, stair rail systems, and guardrail systems are provided in accordance with § 1910.28;

(2) Vertical clearance above any stair tread to any overhead obstruction is at least 6 feet, 8 inches (203 cm), as measured from the leading edge of the tread. Spiral stairs must meet the vertical clearance requirements in paragraph (d)(3) of this section.

(3) Stairs have uniform riser heights and tread depths between landings;

(4) Stairway landings and platforms are at least the width of the stair and at least 30 inches (76 cm) in depth, as measured in the direction of travel;

(5) When a door or a gate opens directly on a stairway, a platform is provided, and the swing of the door or

gate does not reduce the platform's effective usable depth to:

(i) Less than 20 inches (51 cm) for platforms installed before January 17, 2017; and

(ii) Less than 22 inches (56 cm) for platforms installed on or after January 17, 2017 (see Figure D-7 of this section);

(6) Each stair can support at least five times the normal anticipated live load, but never less than a concentrated load of 1,000 pounds (454 kg) applied at any point;

(7) Standard stairs are used to provide access from one walking-working surface to another when operations necessitate regular and routine travel between levels, including access to operating platforms for equipment. Winding stairways may be used on tanks and similar round structures when the diameter of the tank or structure is at least 5 feet (1.5 m).

(8) Spiral, ship, or alternating tread-type stairs are used only when the employer can demonstrate that it is not feasible to provide standard stairs.

(9) When paragraph (b)(8) of this section allows the use of spiral, ship, or alternating tread-type stairs, they are installed, used, and maintained in accordance with manufacturer's instructions.

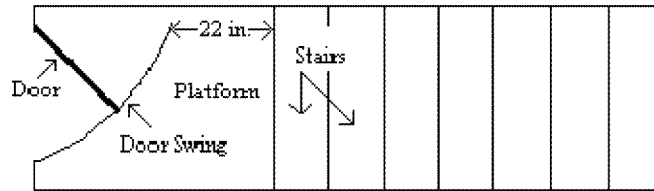

Figure D-7 -- Door or Gate Opening on Stairway

(c) *Standard stairs.* In addition to paragraph (b) of this section, the employer must ensure standard stairs:

- (1) Are installed at angles between 30 to 50 degrees from the horizontal;
- (2) Have a maximum riser height of 9.5 inches (24 cm);

(3) Have a minimum tread depth of 9.5 inches (24 cm); and

(4) Have a minimum width of 22 inches (56 cm) between vertical barriers (see Figure D-8 of this section).

(5) *Exception to paragraphs (c)(2) and (3) of this section.* The requirements of paragraphs (c)(2) and (3) do not apply to

standard stairs installed prior to January 17, 2017. OSHA will deem those stairs in compliance if they meet the dimension requirements specified in Table D-1 of this section or they use a combination that achieves the angle requirements of paragraph (c)(1) of this section.

Table D-1-- Stairway Rise and Tread Dimensions

Angle to horizontal	Rise (in inches)	Tread run (in inches)
30 deg. 35'	6 1/2	11
32 deg. 08'	6 3/4	10 3/4
33 deg. 41'	7	10 1/2
35 deg. 16'	7 1/4	10 1/4
36 deg. 52'	7 1/2	10
38 deg. 29'	7 3/4	9 3/4
40 deg. 08'	8	9 1/2
41 deg. 44'	8 1/4	9 1/4
43 deg. 22'	8 1/2	9
45 deg. 00'	8 3/4	8 3/4
46 deg. 38'	9	8 1/2
48 deg. 16'	9 1/4	8 1/4
49 deg. 54'	9 1/2	8

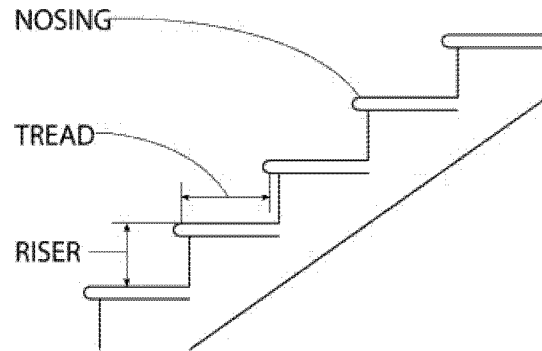

MINIMUM TREAD WIDTH 22 IN (56 CM)

MINIMUM TREAD DEPTH 9.5 IN (24 CM)

MAXIMUM RISER HEIGHT 9.5 IN (24 CM)

(d) *Spiral stairs.* In addition to paragraph (b) of this section, the employer must ensure spiral stairs:

- (1) Have a minimum clear width of 26 inches (66 cm);
- (2) Have a maximum riser height of 9.5 inches (24 cm);
- (3) Have a minimum headroom above spiral stair treads of at least 6 feet, 6 inches (2 m), measured from the leading edge of the tread;

(4) Have a minimum tread depth of 7.5 inches (19 cm), measured at a point 12 inches (30 cm) from the narrower edge;

(5) Have a uniform tread size;

(e) *Ship stairs.* In addition to paragraph (b) of this section, the employer must ensure ship stairs (see Figure D-9 of this section):

(1) Are installed at a slope of 50 to 70 degrees from the horizontal;

(2) Have open risers with a vertical rise between tread surfaces of 6.5 to 12 inches (17 to 30 cm);

(3) Have minimum tread depth of 4 inches (10 cm); and

(4) Have a minimum tread width of 18 inches (46 cm).

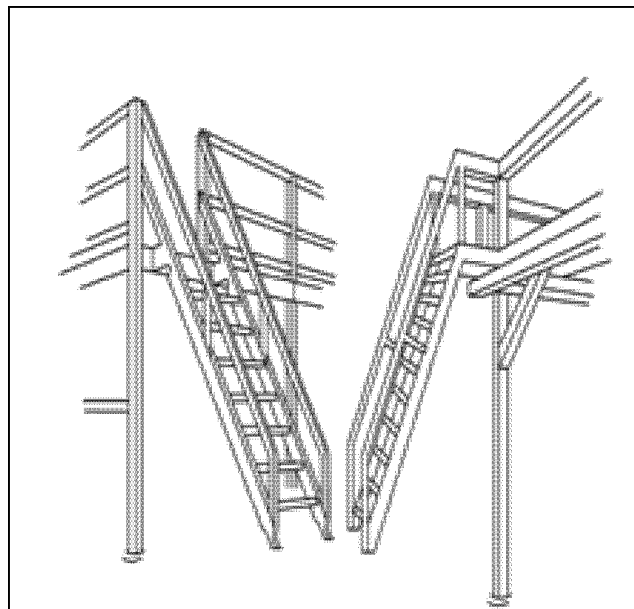

Figure D-9 – Ship Stairs

(f) *Alternating tread-type stairs.* In addition to paragraph (b) of this section, the employer must ensure alternating tread-type stairs:

(1) Have a series of treads installed at a slope of 50 to 70 degrees from the horizontal;

(2) Have a distance between handrails of 17 to 24 inches (51 to 61 cm);

(3) Have a minimum tread depth of 8.5 inches (22 cm); and

(4) Have open risers if the tread depth is less than 9.5 inches (24 cm);

(5) Have a minimum tread width of 7 inches (18 cm), measured at the leading edge of the tread (*i.e.*, nosing).

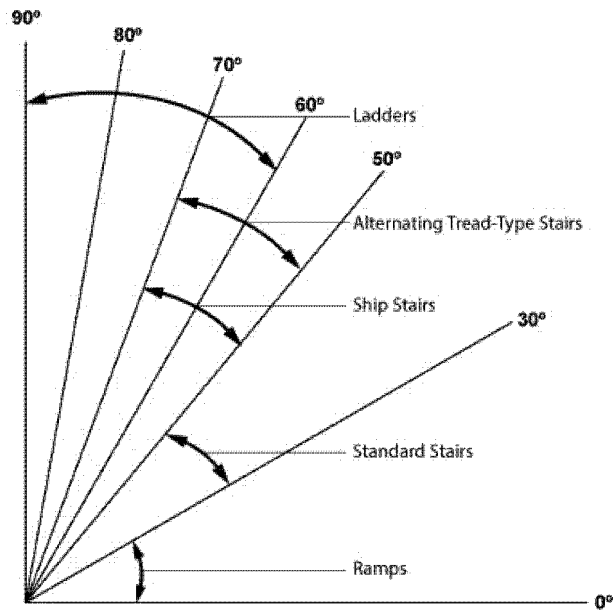

Angle	Type
$\leq 30^\circ$	Ramps
$30^\circ - 50^\circ$	Standard Stairs
$50^\circ - 70^\circ$	Ship Stairs
$50^\circ - 70^\circ$	Alternating Tread-Type Stairs
$60^\circ - 90^\circ$	Ladders

Figure D-10 – Angles for Stairs, Ramps, and Ladders

§ 1910.26 Dockboards.

The employer must ensure that each dockboard used meets the requirements of this section. The employer must ensure:

(a) Dockboards are capable of supporting the maximum intended load in accordance with § 1910.22(b);

(b)(1) Dockboards put into initial service on or after January 17, 2017 are designed, constructed, and maintained to prevent transfer vehicles from running off the dockboard edge;

(2) *Exception to paragraph (b)(1) of this section.* When the employer demonstrates there is no hazard of transfer vehicles running off the dockboard edge, the employer may use dockboards that do not have run-off protection.

(c) Portable dockboards are secured by anchoring them in place or using equipment or devices that prevent the dockboard from moving out of a safe position. When the employer

demonstrates that securing the dockboard is not feasible, the employer must ensure there is sufficient contact between the dockboard and the surface to prevent the dockboard from moving out of a safe position;

(d) Measures, such as wheel chocks or sand shoes, are used to prevent the transport vehicle (e.g. a truck, semi-trailer, trailer, or rail car) on which a dockboard is placed, from moving while employees are on the dockboard; and

(e) Portable dockboards are equipped with handholds or other means to permit safe handling of dockboards.

§ 1910.27 Scaffolds and rope descent systems.

(a) *Scaffolds.* Scaffolds used in general industry must meet the requirements in 29 CFR part 1926, subpart L (Scaffolds).

(b) *Rope descent systems*—(1) *Anchorage.* (i) Before any rope descent system is used, the building owner must

inform the employer, in writing that the building owner has identified, tested, certified, and maintained each anchorage so it is capable of supporting at least 5,000 pounds (268 kg), in any direction, for each employee attached. The information must be based on an annual inspection by a qualified person and certification of each anchorage by a qualified person, as necessary, and at least every 10 years.

(ii) The employer must ensure that no employee uses any anchorage before the employer has obtained written information from the building owner that each anchorage meets the requirements of paragraph (b)(1)(i) of this section. The employer must keep the information for the duration of the job.

(iii) The requirements in paragraphs (b)(1)(i) and (ii) of this section must be implemented no later than November 20, 2017.

(2) *Use of rope descent systems.* The employer must ensure:

(i) No rope descent system is used for heights greater than 300 feet (91 m) above grade unless the employer demonstrates that it is not feasible to access such heights by any other means or that those means pose a greater hazard than using a rope descent system;

(ii) The rope descent system is used in accordance with instructions, warnings, and design limitations set by the manufacturer or under the direction of a qualified person;

(iii) Each employee who uses the rope descent system is trained in accordance with § 1910.30;

(iv) The rope descent system is inspected at the start of each workshift that it is to be used. The employer must ensure damaged or defective equipment is removed from service immediately and replaced;

(v) The rope descent system has proper rigging, including anchorages and tiebacks, with particular emphasis on providing tiebacks when counterweights, cornice hooks, or similar non-permanent anchorages are used;

(vi) Each employee uses a separate, independent personal fall arrest system that meets the requirements of subpart I of this part;

(vii) All components of each rope descent system, except seat boards, are capable of sustaining a minimum rated load of 5,000 pounds (22.2 kN). Seat boards must be capable of supporting a live load of 300 pounds (136 kg);

(viii) Prompt rescue of each employee is provided in the event of a fall;

(ix) The ropes of each rope descent system are effectively padded or otherwise protected, where they can contact edges of the building, anchorage, obstructions, or other surfaces, to prevent them from being cut or weakened;

(x) Stabilization is provided at the specific work location when descents are greater than 130 feet (39.6 m);

(xi) No employee uses a rope descent system when hazardous weather conditions, such as storms or gusty or excessive wind, are present;

(xii) Equipment, such as tools, squeegees, or buckets, is secured by a tool lanyard or similar method to prevent it from falling; and

(xiii) The ropes of each rope descent system are protected from exposure to open flames, hot work, corrosive chemicals, and other destructive conditions.

§ 1910.28 Duty to have fall protection and falling object protection.

(a) *General.* (1) This section requires employers to provide protection for each employee exposed to fall and falling object hazards. Unless stated otherwise, the employer must ensure that all fall protection and falling object protection required by this section meet the criteria in § 1910.29, except that personal fall protection systems required by this section meet the criteria of § 1910.140.

(2) This section does not apply:

(i) To portable ladders;

(ii) When employers are inspecting, investigating, or assessing workplace conditions or work to be performed prior to the start of work or after all work has been completed. This exemption does not apply when fall protection systems or equipment meeting the requirements of § 1910.29 have been installed and are available for workers to use for pre-work and post-work inspections, investigations, or assessments;

(iii) To fall hazards presented by the exposed perimeters of entertainment stages and the exposed perimeters of rail-station platforms;

(iv) To powered platforms covered by § 1910.66(j);

(v) To aerial lifts covered by § 1910.67(c)(2)(v);

(vi) To telecommunications work covered by § 1910.268(n)(7) and (8); and

(vii) To electric power generation, transmission, and distribution work covered by § 1910.269(g)(2)(i).

(b) *Protection from fall hazards—(1) Unprotected sides and edges.* (i) Except as provided elsewhere in this section, the employer must ensure that each employee on a walking-working surface with an unprotected side or edge that is 4 feet (1.2 m) or more above a lower level is protected from falling by one or more of the following:

(A) Guardrail systems;

(B) Safety net systems; or

(C) Personal fall protection systems, such as personal fall arrest, travel restraint, or positioning systems.

(ii) When the employer can demonstrate that it is not feasible or creates a greater hazard to use guardrail, safety net, or personal fall protection systems on residential roofs, the employer must develop and implement a fall protection plan that meets the requirements of 29 CFR 1926.502(k) and training that meets the requirements of 29 CFR 1926.503(a) and (c).

Note to paragraph (b)(1)(ii) of this section: There is a presumption that it is feasible and will not create a greater hazard to use at least one of the above-listed fall protection systems specified in paragraph (b)(1)(i) of

this section. Accordingly, the employer has the burden of establishing that it is not feasible or creates a greater hazard to provide the fall protection systems specified in paragraph (b)(1)(i) and that it is necessary to implement a fall protection plan that complies with § 1926.502(k) in the particular work operation, in lieu of implementing any of those systems.

(iii) When the employer can demonstrate that the use of fall protection systems is not feasible on the working side of a platform used at a loading rack, loading dock, or teeming platform, the work may be done without a fall protection system, provided:

(A) The work operation for which fall protection is infeasible is in process;

(B) Access to the platform is limited to authorized employees; and,

(C) The authorized employees are trained in accordance with § 1910.30.

(2) *Hoist areas.* The employer must ensure:

(i) Each employee in a hoist area is protected from falling 4 feet (1.2 m) or more to a lower level by:

(A) A guardrail system;

(B) A personal fall arrest system; or

(C) A travel restraint system.

(ii) When any portion of a guardrail system, gate, or chains is removed, and an employee must lean through or over the edge of the access opening to facilitate hoisting, the employee is protected from falling by a personal fall arrest system.

(iii) If grab handles are installed at hoist areas, they meet the requirements of § 1910.29(l).

(3) *Holes.* The employer must ensure:

(i) Each employee is protected from falling through any hole (including skylights) that is 4 feet (1.2 m) or more above a lower level by one or more of the following:

(A) Covers;

(B) Guardrail systems;

(C) Travel restraint systems; or

(D) Personal fall arrest systems.

(ii) Each employee is protected from tripping into or stepping into or through any hole that is less than 4 feet (1.2 m) above a lower level by covers or guardrail systems.

(iii) Each employee is protected from falling into a stairway floor hole by a fixed guardrail system on all exposed sides, except at the stairway entrance. However, for any stairway used less than once per day where traffic across the stairway floor hole prevents the use of a fixed guardrail system (e.g., holes located in aisle spaces), the employer may protect employees from falling into the hole by using a hinged floor hole cover that meets the criteria in § 1910.29 and a removable guardrail system on all exposed sides, except at the entrance to the stairway.

(iv) Each employee is protected from falling into a ladderway floor hole or ladderway platform hole by a guardrail system and toeboards erected on all exposed sides, except at the entrance to the hole, where a self-closing gate or an offset must be used.

(v) Each employee is protected from falling through a hatchway and chute-floor hole by:

(A) A hinged floor-hole cover that meets the criteria in § 1910.29 and a fixed guardrail system that leaves only one exposed side. When the hole is not in use, the employer must ensure the cover is closed or a removable guardrail system is provided on the exposed sides;

(B) A removable guardrail system and toeboards on not more than two sides of the hole and a fixed guardrail system on all other exposed sides. The employer must ensure the removable guardrail system is kept in place when the hole is not in use; or

(C) A guardrail system or a travel restraint system when a work operation necessitates passing material through a hatchway or chute floor hole.

(4) *Dockboards.* (i) The employer must ensure that each employee on a dockboard is protected from falling 4 feet (1.2 m) or more to a lower level by a guardrail system or handrails.

(ii) A guardrail system or handrails are not required when:

(A) Dockboards are being used solely for materials-handling operations using motorized equipment;

(B) Employees engaged in these operations are not exposed to fall hazards greater than 10 feet (3 m); and

(C) Those employees have been trained in accordance with § 1910.30.

(5) *Runways and similar walkways.* (i) The employer must ensure each employee on a runway or similar walkway is protected from falling 4 feet (1.2 m) or more to a lower level by a guardrail system.

(ii) When the employer can demonstrate that it is not feasible to have guardrails on both sides of a runway used exclusively for a special purpose, the employer may omit the guardrail on one side of the runway, provided the employer ensures:

(A) The runway is at least 18 inches (46 cm) wide; and

(B) Each employee is provided with and uses a personal fall arrest system or travel restraint system.

(6) *Dangerous equipment.* The employer must ensure:

(i) Each employee less than 4 feet (1.2 m) above dangerous equipment is protected from falling into or onto the dangerous equipment by a guardrail system or a travel restraint system,

unless the equipment is covered or guarded to eliminate the hazard.

(ii) Each employee 4 feet (1.2 m) or more above dangerous equipment must be protected from falling by:

(A) Guardrail systems;

(B) Safety net systems;

(C) Travel restraint systems; or

(D) Personal fall arrest systems.

(7) *Openings.* The employer must ensure that each employee on a walking-working surface near an opening, including one with a chute attached, where the inside bottom edge of the opening is less than 39 inches (99 cm) above that walking-working surface and the outside bottom edge of the opening is 4 feet (1.2 m) or more above a lower level is protected from falling by the use of:

(i) Guardrail systems;

(ii) Safety net systems;

(iii) Travel restraint systems; or,

(iv) Personal fall arrest systems.

(8) *Repair pits, service pits, and assembly pits less than 10 feet in depth.* The use of a fall protection system is not required for a repair pit, service pit, or assembly pit that is less than 10 feet (3 m) deep, provided the employer:

(i) Limits access within 6 feet (1.8 m) of the edge of the pit to authorized employees trained in accordance with § 1910.30;

(ii) Applies floor markings at least 6 feet (1.8 m) from the edge of the pit in colors that contrast with the surrounding area; or places a warning line at least 6 feet (1.8 m) from the edge of the pit as well as stanchions that are capable of resisting, without tipping over, a force of at least 16 pounds (71 N) applied horizontally against the stanchion at a height of 30 inches (76 cm); or places a combination of floor markings and warning lines at least 6 feet (1.8 m) from the edge of the pit. When two or more pits in a common area are not more than 15 feet (4.5m) apart, the employer may comply by placing contrasting floor markings at least 6 feet (1.8 m) from the pit edge around the entire area of the pits; and

(iii) Posts readily visible caution signs that meet the requirements of § 1910.145 and state "Caution—Open Pit."

(9) *Fixed ladders (that extend more than 24 feet (7.3 m) above a lower level).*

(i) For fixed ladders that extend more than 24 feet (7.3 m) above a lower level, the employer must ensure:

(A) *Existing fixed ladders.* Each fixed ladder installed before November 19, 2018 is equipped with a personal fall arrest system, ladder safety system, cage, or well;

(B) *New fixed ladders.* Each fixed ladder installed on and after November 19, 2018, is equipped with a personal

fall arrest system or a ladder safety system;

(C) *Replacement.* When a fixed ladder, cage, or well, or any portion of a section thereof, is replaced, a personal fall arrest system or ladder safety system is installed in at least that section of the fixed ladder, cage, or well where the replacement is located; and

(D) *Final deadline.* On and after November 18, 2036, all fixed ladders are equipped with a personal fall arrest system or a ladder safety system.

(ii) When a one-section fixed ladder is equipped with a personal fall protection or a ladder safety system or a fixed ladder is equipped with a personal fall arrest or ladder safety system on more than one section, the employer must ensure:

(A) The personal fall arrest system or ladder safety system provides protection throughout the entire vertical distance of the ladder, including all ladder sections; and

(B) The ladder has rest platforms provided at maximum intervals of 150 feet (45.7 m).

(iii) The employer must ensure ladder sections having a cage or well:

(A) Are offset from adjacent sections; and

(B) Have landing platforms provided at maximum intervals of 50 feet (15.2 m).

(iv) The employer may use a cage or well in combination with a personal fall arrest system or ladder safety system provided that the cage or well does not interfere with the operation of the system.

(10) *Outdoor advertising (billboards).*

(i) The requirements in paragraph (b)(9) of this section, and other requirements in subparts D and I of this part, apply to fixed ladders used in outdoor advertising activities.

(ii) When an employee engaged in outdoor advertising climbs a fixed ladder before November 19, 2018 that is not equipped with a cage, well, personal fall arrest system, or a ladder safety system the employer must ensure the employee:

(A) Receives training and demonstrates the physical capability to perform the necessary climbs in accordance with § 1910.29(h);

(B) Wears a body harness equipped with an 18-inch (46 cm) rest lanyard;

(C) Keeps both hands free of tools or material when climbing on the ladder; and

(D) Is protected by a fall protection system upon reaching the work position.

(11) *Stairways.* The employer must ensure:

(i) Each employee exposed to an unprotected side or edge of a stairway

landing that is 4 feet (1.2 m) or more above a lower level is protected by a guardrail or stair rail system;

(ii) Each flight of stairs having at least 3 treads and at least 4 risers is equipped

with stair rail systems and handrails as follows:

Table D-2 -- Stairway Handrail Requirements

Stair width	Enclosed	One open side	Two open sides	With earth built up on both sides
Less than 44 inches (1.1 m).	At least one handrail	One stair rail system with handrail on open side.	One stair rail system each open side.	
44 inches (1.1 m) to 88 inches (2.2 m).	One handrail on each enclosed side	One stair rail system with handrail on open side and one handrail on enclosed side.	One stair rail system with handrail on each open side.	
Greater than 88 inches (2.2 m).	One handrail on each enclosed side and one intermediate handrail located in the middle of the stair	One stair rail system with handrail on open side, one handrail on enclosed side, and one intermediate handrail located in the middle of the stair.	One stair rail system with handrail on each open side and one intermediate handrail located in the middle of the stair.	
Exterior stairs less than 44 inches (1.1 m).				One handrail on at least one side.

Note to table: The width of the stair must be clear of all obstructions except handrails.

(iii) Each ship stairs and alternating tread type stairs is equipped with handrails on both sides.

(12) *Scaffolds and rope descent systems.* The employer must ensure:

(i) Each employee on a scaffold is protected from falling in accordance 29 CFR part 1926, subpart L; and

(ii) Each employee using a rope descent system 4 feet (1.2 m) or more above a lower level is protected from falling by a personal fall arrest system.

(13) *Work on low-slope roofs.* (i) When work is performed less than 6 feet (1.6 m) from the roof edge, the employer must ensure each employee is protected from falling by a guardrail system, safety net system, travel restraint system, or personal fall arrest system.

(ii) When work is performed at least 6 feet (1.6 m) but less than 15 feet (4.6 m) from the roof edge, the employer must ensure each employee is protected

from falling by using a guardrail system, safety net system, travel restraint system, or personal fall arrest system.

The employer may use a designated area when performing work that is both infrequent and temporary.

(iii) When work is performed 15 feet (4.6 m) or more from the roof edge, the employer must:

(A) Protect each employee from falling by a guardrail system, safety net system, travel restraint system, or personal fall arrest system or a designated area. The employer is not required to provide any fall protection, provided the work is both infrequent and temporary; and

(B) Implement and enforce a work rule prohibiting employees from going within 15 feet (4.6 m) of the roof edge without using fall protection in accordance with paragraphs (b)(13)(i) and (ii) of this section.

(14) *Slaughtering facility platforms.* (i) The employer must protect each employee on the unprotected working side of a slaughtering facility platform that is 4 feet (1.2 m) or more above a lower level from falling by using:

(A) Guardrail systems; or

(B) Travel restraint systems.

(ii) When the employer can demonstrate the use of a guardrail or travel restraint system is not feasible, the work may be done without those systems provided:

(A) The work operation for which fall protection is infeasible is in process;

(B) Access to the platform is limited to authorized employees; and

(C) The authorized employees are trained in accordance with § 1910.30.

(15) *Walking-working surfaces not otherwise addressed.* Except as provided elsewhere in this section or by other subparts of this part, the employer must

ensure each employee on a walking-working surface 4 feet (1.2 m) or more above a lower level is protected from falling by:

- (i) Guardrail systems;
- (ii) Safety net systems; or
- (iii) Personal fall protection systems, such as personal fall arrest, travel restraint, or positioning systems.

(c) *Protection from falling objects.* When an employee is exposed to falling objects, the employer must ensure that each employee wears head protection that meets the requirements of subpart I of this part. In addition, the employer must protect employees from falling objects by implementing one or more of the following:

- (1) Erecting toeboards, screens, or guardrail systems to prevent objects from falling to a lower level;
- (2) Erecting canopy structures and keeping potential falling objects far enough from an edge, hole, or opening to prevent them from falling to a lower level; or
- (3) Barricading the area into which objects could fall, prohibiting employees from entering the barricaded area, and keeping objects far enough from an edge or opening to prevent them from falling to a lower level.

§ 1910.29 Fall protection systems and falling object protection—criteria and practices.

(a) *General requirements.* The employer must:

- (1) Ensure each fall protection system and falling object protection, other than personal fall protection systems, that this part requires meets the requirements in this section. The employer must ensure each personal fall protection system meets the requirements in subpart I of this part; and
- (2) Provide and install all fall protection systems and falling object protection this subpart requires, and comply with the other requirements in this subpart before any employee begins work that necessitates fall or falling object protection.

(b) *Guardrail systems.* The employer must ensure guardrail systems meet the following requirements:

- (1) The top edge height of top rails, or equivalent guardrail system members, are 42 inches (107 cm), plus or minus

3 inches (8 cm), above the walking-working surface. The top edge height may exceed 45 inches (114 cm), provided the guardrail system meets all other criteria of paragraph (b) of this section (see Figure D–11 of this section).

(2) Midrails, screens, mesh, intermediate vertical members, solid panels, or equivalent intermediate members are installed between the walking-working surface and the top edge of the guardrail system as follows when there is not a wall or parapet that is at least 21 inches (53 cm) high:

- (i) Midrails are installed at a height midway between the top edge of the guardrail system and the walking-working surface;
- (ii) Screens and mesh extend from the walking-working surface to the top rail and along the entire opening between top rail supports;
- (iii) Intermediate vertical members (such as balusters) are installed no more than 19 inches (48 cm) apart; and
- (iv) Other equivalent intermediate members (such as additional midrails and architectural panels) are installed so that the openings are not more than 19 inches (48 cm) wide.

(3) Guardrail systems are capable of withstanding, without failure, a force of at least 200 pounds (890 N) applied in a downward or outward direction within 2 inches (5 cm) of the top edge, at any point along the top rail.

(4) When the 200-pound (890-N) test load is applied in a downward direction, the top rail of the guardrail system must not deflect to a height of less than 39 inches (99 cm) above the walking-working surface.

(5) Midrails, screens, mesh, intermediate vertical members, solid panels, and other equivalent intermediate members are capable of withstanding, without failure, a force of at least 150 pounds (667 N) applied in any downward or outward direction at any point along the intermediate member.

(6) Guardrail systems are smooth-surfaced to protect employees from injury, such as punctures or lacerations, and to prevent catching or snagging of clothing.

(7) The ends of top rails and midrails do not overhang the terminal posts, except where the overhang does not pose a projection hazard for employees.

(8) Steel banding and plastic banding are not used for top rails or midrails.

(9) Top rails and midrails are at least 0.25-inches (0.6 cm) in diameter or in thickness.

(10) When guardrail systems are used at hoist areas, a removable guardrail section, consisting of a top rail and midrail, are placed across the access opening between guardrail sections when employees are not performing hoisting operations. The employer may use chains or gates instead of a removable guardrail section at hoist areas if the employer demonstrates the chains or gates provide a level of safety equivalent to guardrails.

(11) When guardrail systems are used around holes, they are installed on all unprotected sides or edges of the hole.

(12) For guardrail systems used around holes through which materials may be passed:

(i) When materials are being passed through the hole, not more than two sides of the guardrail system are removed; and

(ii) When materials are not being passed through the hole, the hole must be guarded by a guardrail system along all unprotected sides or edges or closed over with a cover.

(13) When guardrail systems are used around holes that serve as points of access (such as ladderways), the guardrail system opening:

(i) Has a self-closing gate that slides or swings away from the hole, and is equipped with a top rail and midrail or equivalent intermediate member that meets the requirements in paragraph (b) of this section; or

(ii) Is offset to prevent an employee from walking or falling into the hole;

(14) Guardrail systems on ramps and runways are installed along each unprotected side or edge.

(15) Manila or synthetic rope used for top rails or midrails are inspected as necessary to ensure that the rope continues to meet the strength requirements in paragraphs (b)(3) and (5) of this section.

Note to paragraph (b) of this section: The criteria and practices requirements for guardrail systems on scaffolds are contained in 29 CFR part 1926, subpart L.

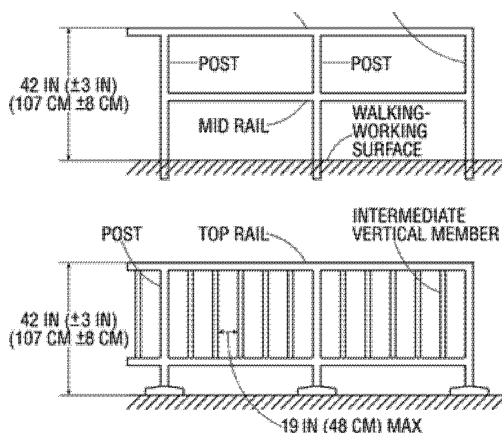

Figure D-11 – Guard Rail Systems

(c) *Safety net systems.* The employer must ensure each safety net system meets the requirements in 29 CFR part 1926, subpart M.

(d) *Designated areas.* (1) When the employer uses a designated area, the employer must ensure:

(i) Employees remain within the designated area while work operations are underway; and

(ii) The perimeter of the designated area is delineated with a warning line consisting of a rope, wire, tape, or chain that meets the requirements of paragraphs (d)(2) and (3) of this section.

(2) The employer must ensure each warning line:

(i) Has a minimum breaking strength of 200 pounds (0.89 kN);

(ii) Is installed so its lowest point, including sag, is not less than 34 inches (86 cm) and not more than 39 inches (99 cm) above the walking-working surface;

(iii) Is supported in such a manner that pulling on one section of the line will not result in slack being taken up in adjacent sections causing the line to fall below the limits specified in paragraph (d)(2)(ii) of this section;

(iv) Is clearly visible from a distance of 25 feet (7.6 m) away, and anywhere within the designated area;

(v) Is erected as close to the work area as the task permits; and

(vi) Is erected not less than 6 feet (1.8 m) from the roof edge for work that is both temporary and infrequent, or not less than 15 feet (4.6 m) for other work.

(3) When mobile mechanical equipment is used to perform work that is both temporary and infrequent in a

designated area, the employer must ensure the warning line is erected not less than 6 feet (1.8 m) from the unprotected side or edge that is parallel to the direction in which the mechanical equipment is operated, and not less than 10 feet (3 m) from the unprotected side or edge that is perpendicular to the direction in which the mechanical equipment is operated.

(e) *Covers.* The employer must ensure each cover for a hole in a walking-working surface:

(1) Is capable of supporting without failure, at least twice the maximum intended load that may be imposed on the cover at any one time; and

(2) Is secured to prevent accidental displacement.

(f) *Handrails and stair rail systems.*

The employer must ensure:

(1) *Height criteria.* (i) Handrails are not less than 30 inches (76 cm) and not more than 38 inches (97 cm), as measured from the leading edge of the stair tread to the top surface of the handrail (see Figure D-12 of this section).

(ii) The height of stair rail systems meets the following:

(A) The height of stair rail systems installed before January 17, 2017 is not less than 30 inches (76 cm) from the leading edge of the stair tread to the top surface of the top rail; and

(B) The height of stair rail systems installed on or after January 17, 2017 is not less than 42 inches (107 cm) from the leading edge of the stair tread to the top surface of the top rail.

(iii) The top rail of a stair rail system may serve as a handrail only when:

(A) The height of the stair rail system is not less than 36 inches (91 cm) and not more than 38 inches (97 cm) as measured at the leading edge of the stair tread to the top surface of the top rail (see Figure D-13 of this section); and

(B) The top rail of the stair rail system meets the other handrail requirements in paragraph (f) of this section.

(2) *Finger clearance.* The minimum clearance between handrails and any other object is 2.25 inches (5.7 cm).

(3) *Surfaces.* Handrails and stair rail systems are smooth-surfaced to protect employees from injury, such as punctures or lacerations, and to prevent catching or snagging of clothing.

(4) *Openings in stair rails.* No opening in a stair rail system exceeds 19 inches (48 cm) at its least dimension.

(5) *Handhold.* Handrails have the shape and dimension necessary so that employees can grasp the handrail firmly.

(6) *Projection hazards.* The ends of handrails and stair rail systems do not present any projection hazards.

(7) *Strength criteria.* Handrails and the top rails of stair rail systems are capable of withstanding, without failure, a force of at least 200 pounds (890 N) applied in any downward or outward direction within 2 inches (5 cm) of any point along the top edge of the rail.

BILLING CODE 4510-29-P

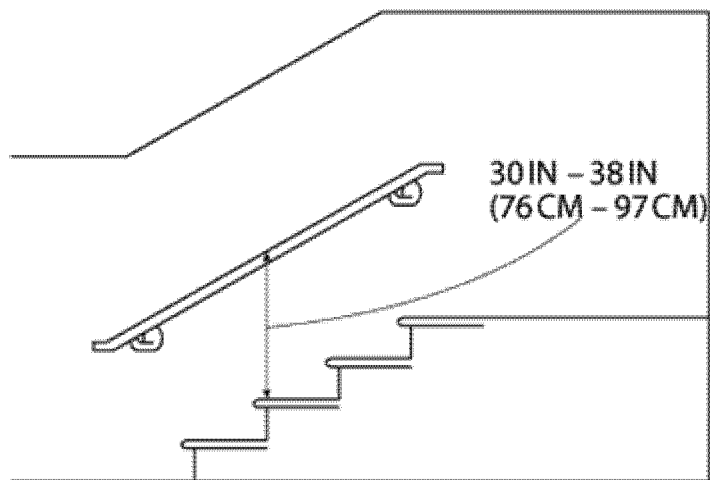

Figure D-12 – Handrail Measurement

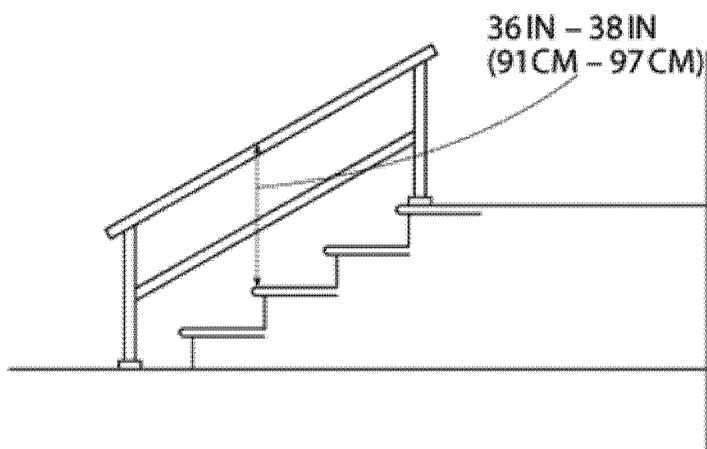

Figure D-13 – Combination Handrail and Stair Rail

BILLING CODE 4510-29-C

(g) *Cages, wells, and platforms used with fixed ladders.* The employer must ensure:

(1) Cages and wells installed on fixed ladders are designed, constructed, and maintained to permit easy access to, and egress from, the ladder that they enclose (see Figures D-14 and D-15 of this section);

(2) Cages and wells are continuous throughout the length of the fixed ladder, except for access, egress, and other transfer points;

(3) Cages and wells are designed, constructed, and maintained to contain employees in the event of a fall, and to direct them to a lower landing; and

(4) Platforms used with fixed ladders provide a horizontal surface of at least

24 inches by 30 inches (61 cm by 76 cm).

Note to paragraph (g): Section 1910.28 establishes the requirements that employers must follow on the use of cages and wells as a means of fall protection.

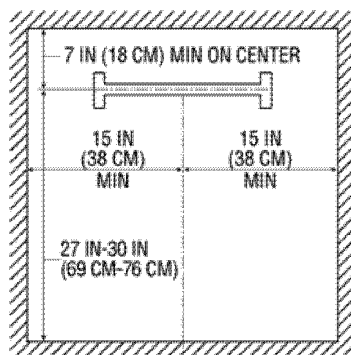

Figure D-14 -- Clearances for Fixed Ladders in Wells

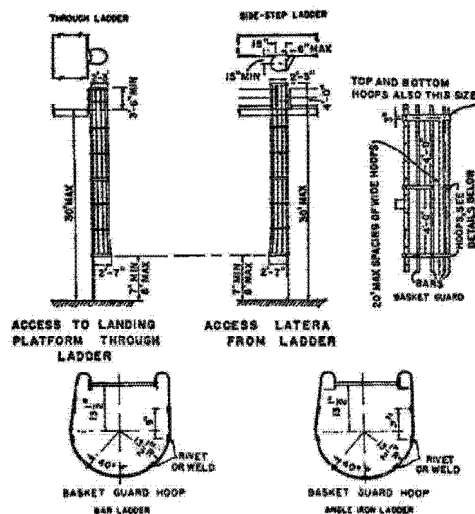

Figure D-15 -- Example of General Construction of Cages

(h) *Outdoor advertising.* This paragraph (h) applies only to employers engaged in outdoor advertising operations (see § 1910.28(b)(10)). Employers must ensure that each employee who climbs a fixed ladder without fall protection:

(1) Is physically capable, as demonstrated through observations of actual climbing activities or by a physical examination, to perform the duties that may be assigned, including climbing fixed ladders without fall protection;

(2) Has successfully completed a training or apprenticeship program that includes hands-on training on the safe climbing of ladders and is retrained as necessary to maintain the necessary skills;

(3) Has the skill to climb ladders safely, as demonstrated through formal classroom training or on-the-job training, and performance observation; and

(4) Performs climbing duties as a part of routine work activity.

(i) *Ladder safety systems.* The employer must ensure:

(1) Each ladder safety system allows the employee to climb up and down using both hands and does not require that the employee continuously hold, push, or pull any part of the system while climbing;

(2) The connection between the carrier or lifeline and the point of attachment to the body harness or belt does not exceed 9 inches (23 cm);

(3) Mountings for rigid carriers are attached at each end of the carrier, with intermediate mountings spaced, as necessary, along the entire length of the carrier so the system has the strength to stop employee falls;

(4) Mountings for flexible carriers are attached at each end of the carrier and cable guides for flexible carriers are installed at least 25 feet (7.6 m) apart but not more than 40 feet (12.2 m) apart along the entire length of the carrier;

(5) The design and installation of mountings and cable guides does not

reduce the design strength of the ladder; and

(6) Ladder safety systems and their support systems are capable of withstanding, without failure, a drop test consisting of an 18-inch (41-cm) drop of a 500-pound (227-kg) weight.

(j) *Personal fall protection systems.*

Body belts, harnesses, and other components used in personal fall arrest systems, work positioning systems, and travel restraint systems must meet the requirements of § 1910.140.

(k) *Protection from falling objects.* (1)

The employers must ensure toeboards used for falling object protection:

(i) Are erected along the exposed edge of the overhead walking-working surface for a length that is sufficient to protect employees below.

(ii) Have a minimum vertical height of 3.5 inches (9 cm) as measured from the top edge of the toeboard to the level of the walking-working surface.

(iii) Do not have more than a 0.25-inch (0.5-cm) clearance or opening above the walking-working surface.

(iv) Are solid or do not have any opening that exceeds 1 inch (3 cm) at its greatest dimension.

(v) Have a minimum height of 2.5 inches (6 cm) when used around vehicle repair, service, or assembly pits. Toeboards may be omitted around vehicle repair, service, or assembly pits when the employer can demonstrate that a toeboard would prevent access to a vehicle that is over the pit.

(vi) Are capable of withstanding, without failure, a force of at least 50 pounds (222 N) applied in any downward or outward direction at any point along the toeboard.

(2) The employer must ensure:

(i) Where tools, equipment, or materials are piled higher than the top of the toeboard, paneling or screening is installed from the toeboard to the midrail of the guardrail system and for a length that is sufficient to protect employees below. If the items are piled higher than the midrail, the employer also must install paneling or screening to the top rail and for a length that is sufficient to protect employees below; and

(ii) All openings in guardrail systems are small enough to prevent objects from falling through the opening.

(3) The employer must ensure canopies used for falling object protection are strong enough to prevent collapse and to prevent penetration by falling objects.

(l) *Grab handles.* The employer must ensure each grab handle:

(1) Is not less than 12 inches (30 cm) long;

(2) Is mounted to provide at least 3 inches (8 cm) of clearance from the framing or opening; and

(3) Is capable of withstanding a maximum horizontal pull-out force equal to two times the maximum intended load or 200 pounds (890 N), whichever is greater.

§ 1910.30 Training requirements.

(a) *Fall hazards.* (1) Before any employee is exposed to a fall hazard, the employer must provide training for each employee who uses personal fall protection systems or who is required to be trained as specified elsewhere in this subpart. Employers must ensure employees are trained in the requirements of this paragraph on or before May 17, 2017.

(2) The employer must ensure that each employee is trained by a qualified person.

(3) The employer must train each employee in at least the following topics:

(i) The nature of the fall hazards in the work area and how to recognize them;

(ii) The procedures to be followed to minimize those hazards;

(iii) The correct procedures for installing, inspecting, operating, maintaining, and disassembling the personal fall protection systems that the employee uses; and

(iv) The correct use of personal fall protection systems and equipment specified in paragraph (a)(1) of this section, including, but not limited to, proper hook-up, anchoring, and tie-off techniques, and methods of equipment inspection and storage, as specified by the manufacturer.

(b) *Equipment hazards.* (1) The employer must train each employee on or before May 17, 2017 in the proper care, inspection, storage, and use of equipment covered by this subpart before an employee uses the equipment.

(2) The employer must train each employee who uses a dockboard to properly place and secure it to prevent unintentional movement.

(3) The employer must train each employee who uses a rope descent system in proper rigging and use of the equipment in accordance with § 1910.27.

(4) The employer must train each employee who uses a designated area in the proper set-up and use of the area.

(c) *Retraining.* The employer must retrain an employee when the employer has reason to believe the employee does not have the understanding and skill required by paragraphs (a) and (b) of this section. Situations requiring retraining include, but are not limited to, the following:

(1) When changes in the workplace render previous training obsolete or inadequate;

(2) When changes in the types of fall protection systems or equipment to be used render previous training obsolete or inadequate; or

(3) When inadequacies in an affected employee's knowledge or use of fall protection systems or equipment indicate that the employee no longer has the requisite understanding or skill necessary to use equipment or perform the job safely.

(d) *Training must be understandable.* The employer must provide information and training to each employee in a manner that the employee understands.

Subpart F—[Amended]

■ 4. Revise the authority citation for subpart F to read as follows:

Authority: 29 U.S.C. 653, 655, and 657; Secretary of Labor's Order No. 12-71 (36 FR 8754), 8-76 (41 FR 25059), 9-83 (48 FR 35736), 1-90 (55 FR 9033), 5-2007 (72 FR 31159), or 1-2012 (77 FR 3912), as applicable; and 29 CFR part 1911.

■ 5. In § 1910.66:

■ a. Revise paragraphs (b)(2)(i), (c)(3), (f)(5)(ii)(L) and (M), (f)(5)(iii)(B), and (j);

■ b. Remove and reserve appendix C; and

■ c. Revise appendix D, paragraph (c)(4).

The revisions read as follows:

§ 1910.66 Powered platforms for building maintenance.

* * * * *

(b) * * *

(2) * * *

(i) Permanent installations in existence and/or completed before July 23, 1990 shall comply with paragraphs (g), (h), (i), (j) and appendix C to subpart I of this part.

* * * * *

(c) * * *

(3) Building owners of all installations, new and existing, shall inform the employer in writing that the installation has been inspected, tested, and maintained in compliance with the requirements of paragraphs (g) and (h) of this section and that all anchorages meet the requirements of § 1910.140(c)(13).

* * * * *

(f) * * *

(5) * * *

(ii) * * *

(L) The platform shall be provided with a secondary wire rope suspension system if the platform contains overhead structures which restrict the emergency egress of employees. A horizontal lifeline or a direct connection anchorage shall be provided as part of a personal fall arrest system that meets the requirements of subpart I of this part for each employee on such a platform.

(M) A vertical lifeline shall be provided as part of a personal fall arrest system that meets the requirements of subpart I of this part for each employee on a working platform suspended by two or more wire ropes, if the failure of one wire rope or suspension attachment will cause the platform to upset. If a secondary wire rope suspension is used, vertical lifelines are not required for the personal fall arrest system, provided that each employee is attached to a horizontal lifeline anchored to the platform.

* * * * *

(iii) * * *

(B) Each single point suspended working platform shall be provided with a secondary wire rope suspension system which will prevent the working platform from falling should there be a failure of the primary means of support, or if the platform contains overhead structures which restrict the egress of

the employees. A horizontal life line or a direct connection anchorage shall be provided as part of a personal fall arrest system that meets the requirements of subpart I of this part for each employee on the platform.

* * * * *

(j) *Personal fall protection.* Employees on working platforms shall be protected by a personal fall arrest system meeting the requirements of subpart I of this part and as otherwise provided by this standard.

* * * * *

Appendix C to § 1910.66 [Reserved]

Appendix D to § 1910.66—Existing Installations (Mandatory)

* * * * *

(c) * * *

(4) *Access to the roof car.* Safe access to the roof car and from the roof car to the working platform shall be provided. If the access to the roof car at any point of its travel is not over the roof area or where otherwise necessary for safety, then self-closing, self-locking gates shall be provided. Access to and from roof cars must comply with the requirements of subpart D of this part.

* * * * *

■ 6. In § 1910.67, revise paragraph (c)(2)(v) to read as follows:

§ 1910.67 Vehicle-mounted elevating and rotating work platforms.

* * * * *

(c) * * *

(2) * * *

(v) A personal fall arrest or travel restraint system that meets the requirements in subpart I of this part shall be worn and attached to the boom or basket when working from an aerial lift.

* * * * *

■ 7. In § 1910.68, revise paragraphs (b)(8)(ii) and (b)(12) to read as follows:

§ 1910.68 Manlifts.

* * * * *

(b) * * *

(8) * * *

(ii) *Construction.* The rails shall be standard guardrails with toeboards that meet the requirements in subpart D of this part.

* * * * *

(12) *Emergency exit ladder.* A fixed metal ladder accessible from both the “up” and “down” run of the manlift shall be provided for the entire travel of the manlift. Such ladders shall meet the requirements in subpart D of this part.

* * * * *

Subpart I—[Amended]

■ 8. Revise the authority citation for subpart I to read as follows:

Authority: 29 U.S.C. 653, 655, 657; Secretary of Labor’s Order No. 12–71 (36 FR 8754), 8–76 (41 FR 25059), 9–83 (48 FR 35736), 1–90 (55 FR 9033), 6–96 (62 FR 111), 3–2000 (65 FR 50017), 5–2002 (67 FR 65008), 5–2007 (72 FR 31159), 4–2010 (75 FR 55355), or 1–2012 (77 FR 3912), as applicable; and 29 CFR part 1911.

■ 9. In § 1910.132, revise paragraph (g) to read as follows:

§ 1910.132 General requirements.

* * * * *

(g) Paragraphs (d) and (f) of this section apply only to §§ 1910.133, 1910.135, 1910.136, 1910.138, and 1910.140. Paragraphs (d) and (f) of this section do not apply to §§ 1910.134 and 1910.137.

* * * * *

§ 1910.139 [Added and Reserved]

■ 10. Add reserved § 1910.139.

■ 11. Add § 1910.140 to read as follows:

§ 1910.140 Personal fall protection systems.

(a) *Scope and application.* This section establishes performance, care, and use criteria for all personal fall protection systems. The employer must ensure that each personal fall protection system used to comply with this part must meet the requirements of this section.

(b) *Definitions.* The following definitions apply to this section:

Anchorage means a secure point of attachment for equipment such as lifelines, lanyards, or deceleration devices.

Belt terminal means an end attachment of a window cleaner’s positioning system used for securing the belt or harness to a window cleaner’s belt anchor.

Body belt means a strap with means both for securing about the waist and for attaching to other components such as a lanyard used with positioning systems, travel restraint systems, or ladder safety systems.

Body harness means straps that secure about the employee in a manner to distribute the fall arrest forces over at least the thighs, pelvis, waist, chest, and shoulders, with a means for attaching the harness to other components of a personal fall protection system.

Carabiner means a connector generally comprised of a trapezoidal or oval shaped body with a closed gate or similar arrangement that may be opened to attach another object and, when released, automatically closes to retain the object.

Competent person means a person who is capable of identifying existing and predictable hazards in any personal

fall protection system or any component of it, as well as in their application and uses with related equipment, and who has authorization to take prompt, corrective action to eliminate the identified hazards.

Connector means a device used to couple (connect) parts of the fall protection system together.

D-ring means a connector used:

(i) In a harness as an integral attachment element or fall arrest attachment;

(ii) In a lanyard, energy absorber, lifeline, or anchorage connector as an integral connector; or

(iii) In a positioning or travel restraint system as an attachment element.

Deceleration device means any mechanism that serves to dissipate energy during a fall.

Deceleration distance means the vertical distance a falling employee travels from the point at which the deceleration device begins to operate, excluding lifeline elongation and free fall distance, until stopping. It is measured as the distance between the location of an employee’s body harness attachment point at the moment of activation (at the onset of fall arrest forces) of the deceleration device during a fall, and the location of that attachment point after the employee comes to a full stop.

Equivalent means alternative designs, equipment, materials, or methods that the employer can demonstrate will provide an equal or greater degree of safety for employees compared to the designs, equipment, materials, or methods specified in the standard.

Free fall means the act of falling before the personal fall arrest system begins to apply force to arrest the fall.

Free fall distance means the vertical displacement of the fall arrest attachment point on the employee’s body belt or body harness between onset of the fall and just before the system begins to apply force to arrest the fall. This distance excludes deceleration distance, lifeline and lanyard elongation, but includes any deceleration device slide distance or self-retracting lifeline/lanyard extension before the devices operate and fall arrest forces occur.

Lanyard means a flexible line of rope, wire rope, or strap that generally has a connector at each end for connecting the body belt or body harness to a deceleration device, lifeline, or anchorage.

Lifeline means a component of a personal fall protection system consisting of a flexible line for connection to an anchorage at one end so as to hang vertically (vertical

lifeline), or for connection to anchorages at both ends so as to stretch horizontally (horizontal lifeline), and serves as a means for connecting other components of the system to the anchorage.

Personal fall arrest system means a system used to arrest an employee in a fall from a walking-working surface. It consists of a body harness, anchorage, and connector. The means of connection may include a lanyard, deceleration device, lifeline, or a suitable combination of these.

Personal fall protection system means a system (including all components) an employer uses to provide protection from falling or to safely arrest an employee's fall if one occurs.

Examples of personal fall protection systems include personal fall arrest systems, positioning systems, and travel restraint systems.

Positioning system (work-positioning system) means a system of equipment and connectors that, when used with a body harness or body belt, allows an employee to be supported on an elevated vertical surface, such as a wall or window sill, and work with both hands free. Positioning systems also are called "positioning system devices" and "work-positioning equipment."

Qualified describes a person who, by possession of a recognized degree, certificate, or professional standing, or who by extensive knowledge, training, and experience has successfully demonstrated the ability to solve or resolve problems relating to the subject matter, the work, or the project.

Rope grab means a deceleration device that travels on a lifeline and automatically, by friction, engages the lifeline and locks so as to arrest the fall of an employee. A rope grab usually employs the principle of inertial locking, cam/lever locking, or both.

Safety factor means the ratio of the design load and the ultimate strength of the material.

Self-retracting lifeline/lanyard means a deceleration device containing a drum-wound line that can be slowly extracted from, or retracted onto, the drum under slight tension during normal movement by the employee. At the onset of a fall, the device automatically locks the drum and arrests the fall.

Snaphook means a connector comprised of a hook-shaped body with a normally closed gate, or similar arrangement that may be manually opened to permit the hook to receive an object. When released, the snaphook automatically closes to retain the object. Opening a snaphook requires two separate actions. Snaphooks are generally one of two types:

(i) Automatic-locking type (permitted) with a self-closing and self-locking gate that remains closed and locked until intentionally unlocked and opened for connection or disconnection; and

(ii) Non-locking type (prohibited) with a self-closing gate that remains closed, but not locked, until intentionally opened for connection or disconnection.

Travel restraint (tether) line means a rope or wire rope used to transfer forces from a body support to an anchorage or anchorage connector in a travel restraint system.

Travel restraint system means a combination of an anchorage, anchorage connector, lanyard (or other means of connection), and body support that an employer uses to eliminate the possibility of an employee going over the edge of a walking-working surface.

Window cleaner's belt means a positioning belt that consists of a waist belt, an integral terminal runner or strap, and belt terminals.

Window cleaner's belt anchor (window anchor) means specifically designed fall-preventing attachment points permanently affixed to a window frame or to a building part immediately adjacent to the window frame, for direct attachment of the terminal portion of a window cleaner's belt.

Window cleaner's positioning system means a system which consists of a window cleaner's belt secured to window anchors.

Work-positioning system (see *Positioning system* in this paragraph (b)).

(c) *General requirements.* The employer must ensure that personal fall protection systems meet the following requirements. Additional requirements for personal fall arrest systems and positioning systems are contained in paragraphs (d) and (e) of this section, respectively.

(1) Connectors must be drop forged, pressed or formed steel, or made of equivalent materials.

(2) Connectors must have a corrosion-resistant finish, and all surfaces and edges must be smooth to prevent damage to interfacing parts of the system.

(3) When vertical lifelines are used, each employee must be attached to a separate lifeline.

(4) Lanyards and vertical lifelines must have a minimum breaking strength of 5,000 pounds (22.2 kN).

(5) Self-retracting lifelines and lanyards that automatically limit free fall distance to 2 feet (0.61 m) or less must have components capable of sustaining a minimum tensile load of 3,000 pounds (13.3 kN) applied to the

device with the lifeline or lanyard in the fully extended position.

(6) A competent person or qualified person must inspect each knot in a lanyard or vertical lifeline to ensure that it meets the requirements of paragraphs (c)(4) and (5) of this section before any employee uses the lanyard or lifeline.

(7) D-rings, snaphooks, and carabiners must be capable of sustaining a minimum tensile load of 5,000 pounds (22.2 kN).

(8) D-rings, snaphooks, and carabiners must be proof tested to a minimum tensile load of 3,600 pounds (16 kN) without cracking, breaking, or incurring permanent deformation. The gate strength of snaphooks and carabiners, must be proof tested to 3,600 lbs. (16 kN) in all directions.

(9) Snaphooks and carabiners must be the automatic locking type that require at least two separate, consecutive movements to open.

(10) Snaphooks and carabiners must not be connected to any of the following unless they are designed for such connections:

(i) Directly to webbing, rope, or wire rope;

(ii) To each other;

(iii) To a D-ring to which another snaphook, carabiner, or connector is attached;

(iv) To a horizontal life line; or

(v) To any object that is incompatibly shaped or dimensioned in relation to the snaphook or carabiner such that unintentional disengagement could occur when the connected object depresses the snaphook or carabiner gate, allowing the components to separate.

(11) The employer must ensure that each horizontal lifeline:

(i) Is designed, installed, and used under the supervision of a qualified person; and

(ii) Is part of a complete personal fall arrest system that maintains a safety factor of at least two.

(12) Anchorages used to attach to personal fall protection equipment must be independent of any anchorage used to suspend employees or platforms on which employees work. Anchorages used to attach to personal fall protection equipment on mobile work platforms on powered industrial trucks must be attached to an overhead member of the platform, at a point located above and near the center of the platform.

(13) Anchorages, except window cleaners' belt anchors covered by paragraph (e) of this section, must be:

(i) Capable of supporting at least 5,000 pounds (22.2 kN) for each employee attached; or

(ii) Designed, installed, and used, under the supervision of qualified

person, as part of a complete personal fall protection system that maintains a safety factor of at least two.

(14) Travel restraint lines must be capable of sustaining a tensile load of at least 5,000 pounds (22.2 kN).

(15) Lifelines must not be made of natural fiber rope. Polypropylene rope must contain an ultraviolet (UV) light inhibitor.

(16) Personal fall protection systems and their components must be used exclusively for employee fall protection and not for any other purpose, such as hoisting equipment or materials.

(17) A personal fall protection system or its components subjected to impact loading must be removed from service immediately and not used again until a competent person inspects the system or components and determines that it is not damaged and safe for use for employee personal fall protection.

(18) Personal fall protection systems must be inspected before initial use during each workshift for mildew, wear, damage, and other deterioration, and defective components must be removed from service.

(19) Ropes, belts, lanyards, and harnesses used for personal fall protection must be compatible with all connectors used.

(20) Ropes, belts, lanyards, lifelines, and harnesses used for personal fall protection must be protected from being cut, abraded, melted, or otherwise damaged.

(21) The employer must provide for prompt rescue of each employee in the event of a fall.

(22) Personal fall protection systems must be worn with the attachment point of the body harness located in the center of the employee's back near shoulder level. The attachment point may be located in the pre-sternal position if the free fall distance is limited to 2 feet (0.6 m) or less.

(d) *Personal fall arrest systems*—(1) *System performance criteria*. In addition

to the general requirements in paragraph (c) of this section, the employer must ensure that personal fall arrest systems:

(i) Limit the maximum arresting force on the employee to 1,800 pounds (8 kN);

(ii) Bring the employee to a complete stop and limit the maximum deceleration distance the employee travels to 3.5 feet (1.1 m);

(iii) Have sufficient strength to withstand twice the potential impact energy of the employee free falling a distance of 6 feet (1.8 m), or the free fall distance permitted by the system; and

(iv) Sustain the employee without making contact with the employee's neck and chin area.

(v) If the personal fall arrest system meets the criteria and protocols in appendix D of this subpart, and is being used by an employee having a combined body and tool weight of less than 310 pounds (140 kg), the system is considered to be in compliance with the provisions of paragraphs (d)(1)(i) through (iii) of this section. If the system is used by an employee having a combined body and tool weight of 310 pounds (140kg) or more and the employer has appropriately modified the criteria and protocols in appendix D, then the system will be deemed to be in compliance with the requirements of paragraphs (d)(1)(i) through (iii).

(2) *System use criteria*. The employer must ensure that:

(i) On any horizontal lifeline that may become a vertical lifeline, the device used to connect to the horizontal lifeline is capable of locking in both directions on the lifeline.

(ii) Personal fall arrest systems are rigged in such a manner that the employee cannot free fall more than 6 feet (1.8 m) or contact a lower level. A free fall may be more than 6 feet (1.8 m) provided the employer can demonstrate the manufacturer designed the system to allow a free fall of more than 6 feet and tested the system to ensure a maximum

arresting force of 1,800 pounds (8 kN) is not exceeded.

(3) *Body belts*. Body belts are prohibited as part of a personal fall arrest system.

(e) *Positioning systems*—(1) *System performance requirements*. The employer must ensure that each positioning system meets the following requirements:

(i) *General*. All positioning systems, except window cleaners' positioning systems, are capable of withstanding, without failure, a drop test consisting of a 4-foot (1.2-m) drop of a 250-pound (113-kg) weight;

(ii) *Window cleaners' positioning systems*. All window cleaners' positioning systems must:

(A) Be capable of withstanding without failure a drop test consisting of a 6-foot (1.8-m) drop of a 250-pound (113-kg) weight; and

(B) Limit the initial arresting force on the falling employee to not more than 2,000 pounds (8.9 kN), with a duration not exceeding 2 milliseconds and any subsequent arresting forces to not more than 1,000 pounds (4.5 kN).

(iii) Positioning systems, including window cleaners' positioning systems, that meet the test methods and procedures in appendix D of this subpart are considered to be in compliance with paragraphs (e)(1)(i) and (ii).

(iv) *Lineman's body belt and pole strap systems*. Lineman's body belt and pole strap systems must meet the following tests:

(A) A dielectric test of 819.7 volts, AC, per centimeter (25,000 volts per foot) for 3 minutes without visible deterioration;

(B) A leakage test of 98.4 volts, AC, per centimeter (3,000 volts per foot) with a leakage current of no more than 1 mA; and

(C) A flammability test in accordance with Table I-7 of this section.

Table I-7 -- Flammability Test

Test Method	Criteria for Passing Test
<ol style="list-style-type: none"> 1. Vertically suspend a 19.7-inch (500-mm) length of strapping supporting a 220.5-lb (100-kg) weight; 2. Use a butane or propane burner with a 3-inch (76-mm) flame; 3. Direct the flame to an edge of the strapping at a distance of 1 inch (25mm); 4. Remove the flame after 5 seconds; and 5. Wait for any flames on the positioning strap to stop burning. 	<p>Any flames on the positioning strap must self-extinguish.</p> <p>The positioning strap must continue to support the 220.5-lb (100-kg) mass.</p>

(2) *System use criteria for window cleaners' positioning systems.* The employer must ensure that window cleaners' positioning systems meet and are used in accordance with the following:

(i) Window cleaners' belts are designed and constructed so that:

(A) Belt terminals will not pass through their fastenings on the belt or harness if a terminal comes loose from the window anchor; and

(B) The length of the runner from terminal tip to terminal tip is 8 feet (2.44 m) or less;

(ii) Window anchors to which belts are fastened are installed in the side frames or mullions of the window at a point not less than 42 inches (106.7 cm) and not more than 51 inches (129.5 cm) above the window sill;

(iii) Each window anchor is capable of supporting a minimum load of 6,000 pounds (26.5 kN);

(iv) Use of installed window anchors for any purpose other than attaching the window cleaner's belt is prohibited;

(v) A window anchor that has damaged or deteriorated fastenings or supports is removed, or the window anchor head is detached so the anchor cannot be used;

(vi) Rope that has wear or deterioration that affects its strength is not used;

(vii) Both terminals of the window cleaner's belt are attached to separate

window anchors during any cleaning operation;

(viii) No employee works on a window sill or ledge on which there is snow, ice, or any other slippery condition, or one that is weakened or rotted;

(ix) No employee works on a window sill or ledge unless:

(A) The window sill or ledge is a minimum of 4 inches (10 cm) wide and slopes no more than 15 degrees below horizontal; or

(B) The 4-inch minimum width of the window sill or ledge is increased 0.4 inches (1 cm) for every degree the sill or ledge slopes beyond 15 degrees, up to a maximum of 30 degrees;

(x) The employee attaches at least one belt terminal to a window anchor before climbing through the window opening, and keeps at least one terminal attached until completely back inside the window opening;

(xi) Except as provided in paragraph (e)(2)(xii) of this section, the employee travels from one window to another by returning inside the window opening and repeating the belt terminal attachment procedure at each window in accordance with paragraph (e)(2)(x) of this section;

(xii) An employee using a window cleaner's positioning system may travel from one window to another while outside of the building, provided:

(A) At least one belt terminal is attached to a window anchor at all times;

(B) The distance between window anchors does not exceed 4 feet (1.2 m) horizontally. The distance between windows may be increased up to 6 feet (1.8 m) horizontally if the window sill or ledge is at least 1 foot (0.31 m) wide and the slope is less than 5 degrees;

(C) The sill or ledge between windows is continuous; and

(D) The width of the window sill or ledge in front of the mullions is at least 6 inches (15.2 cm) wide.

■ 12. Add appendices C and D to subpart I of part 1910 to read as follows:

**Appendix C to Subpart I of Part 1910—
Personal Fall Protection Systems Non-Mandatory Guidelines**

The following information generally applies to all personal fall protection systems and is intended to assist employers and employees comply with the requirements of § 1910.140 for personal fall protection systems.

(a) Planning considerations. It is important for employers to plan prior to using personal fall protection systems. Probably the most overlooked component of planning is locating suitable anchorage points. Such planning should ideally be done before the structure or building is constructed so that anchorage points can be used later for window cleaning or other building maintenance.

(b) Selection and use considerations. (1) The kind of personal fall protection system

selected should be appropriate for the employee's specific work situation. Free fall distances should always be kept to a minimum. Many systems are designed for particular work applications, such as climbing ladders and poles; maintaining and servicing equipment; and window cleaning. Consideration should be given to the environment in which the work will be performed. For example, the presence of acids, dirt, moisture, oil, grease, or other substances, and their potential effects on the system selected, should be evaluated. The employer should fully evaluate the work conditions and environment (including seasonal weather changes) before selecting the appropriate personal fall protection system. Hot or cold environments may also affect fall protection systems. Wire rope should not be used where electrical hazards are anticipated. As required by § 1910.140(c)(21), the employer must provide a means for promptly rescuing an employee should a fall occur.

(2) Where lanyards, connectors, and lifelines are subject to damage by work operations, such as welding, chemical cleaning, and sandblasting, the component should be protected, or other securing systems should be used. A program for cleaning and maintaining the system may be necessary.

(c) Testing considerations. Before purchasing a personal fall protection system, an employer should insist that the supplier provide information about its test performance (using recognized test methods) so the employer will know that the system meets the criteria in § 1910.140. Otherwise, the employer should test the equipment to ensure that it is in compliance. Appendix D to this subpart contains test methods which are recommended for evaluating the performance of any system. There are some circumstances in which an employer can evaluate a system based on data and calculations derived from the testing of similar systems. Enough information must be available for the employer to demonstrate that its system and the tested system(s) are similar in both function and design.

(d) Component compatibility considerations. Ideally, a personal fall protection system is designed, tested, and supplied as a complete system. However, it is common practice for lanyards, connectors, lifelines, deceleration devices, body belts, and body harnesses to be interchanged since some components wear out before others. Employers and employees should realize that not all components are interchangeable. For instance, a lanyard should not be connected between a body harness and a deceleration device of the self-retracting type (unless specifically allowed by the manufacturer) since this can result in additional free fall for which the system was not designed. In addition, positioning components, such as pole straps, ladder hooks and rebar hooks, should not be used in personal fall arrest systems unless they meet the appropriate strength and performance requirements of part 1910 (e.g., §§ 1910.140, 1910.268 and 1910.269). Any substitution or change to a personal fall protection system should be fully evaluated or tested by a competent

person to determine that it meets applicable OSHA standards before the modified system is put in use. Also, OSHA suggests that rope be used according to manufacturers' recommendations, especially if polypropylene rope is used.

(e) Employee training considerations. As required by §§ 1910.30 and 1910.132, before an employee uses a fall protection system, the employer must ensure that he or she is trained in the proper use of the system. This may include the following: The limits of the system; proper anchoring and tie-off techniques; estimating free fall distance, including determining elongation and deceleration distance; methods of use; and inspection and storage. Careless or improper use of fall protection equipment can result in serious injury or death. Employers and employees should become familiar with the material in this standard and appendix, as well as manufacturers' recommendations, before a system is used. It is important for employees to be aware that certain tie-offs (such as using knots and tying around sharp edges) can reduce the overall strength of a system. Employees also need to know the maximum permitted free fall distance. Training should stress the importance of inspections prior to use, the limitations of the equipment to be used, and unique conditions at the worksite that may be important.

(f) Instruction considerations. Employers should obtain comprehensive instructions from the supplier or a qualified person as to the system's proper use and application, including, where applicable:

- (1) The force measured during the sample force test;
- (2) The maximum elongation measured for lanyards during the force test;
- (3) The deceleration distance measured for deceleration devices during the force test;
- (4) Caution statements on critical use limitations;
- (5) Limits of the system;
- (6) Proper hook-up, anchoring and tie-off techniques, including the proper D-ring or other attachment point to use on the body harness;
- (7) Proper climbing techniques;
- (8) Methods of inspection, use, cleaning, and storage; and
- (9) Specific lifelines that may be used.

(g) Inspection considerations. Personal fall protection systems must be inspected before initial use in each workshift. Any component with damage, such as a cut, tear, abrasion, mold, or evidence of undue stretching, an alteration or addition that might affect its effectiveness, damage due to deterioration, fire, acid, or other corrosive damage, distorted hooks or faulty hook springs, tongues that are unfitted to the shoulder of buckles, loose or damaged mountings, non-functioning parts, or wear, or internal deterioration must be removed from service immediately, and should be tagged or marked as unusable, or destroyed. Any personal fall protection system, including components, subjected to impact loading must be removed from service immediately and not used until a competent person inspects the system and determines that it is not damaged and is safe to use for personal fall protection.

(h) Rescue considerations. As required by § 1910.140(c)(21), when personal fall arrest

systems are used, special consideration must be given to rescuing an employee promptly should a fall occur. The availability of rescue personnel, ladders, or other rescue equipment needs to be evaluated since there may be instances in which employees cannot self-rescue (e.g., employee unconscious or seriously injured). In some situations, equipment allowing employees to rescue themselves after the fall has been arrested may be desirable, such as devices that have descent capability.

(i) Tie-off considerations. Employers and employees should at all times be aware that the strength of a personal fall arrest system is based on its being attached to an anchoring system that can support the system.

Therefore, if a means of attachment is used that will reduce the strength of the system (such as an eye-bolt/snaphook anchorage), that component should be replaced by a stronger one that will also maintain the appropriate maximum deceleration characteristics. The following is a listing of some situations in which employers and employees should be especially cautious:

(1) Tie-off using a knot in the lanyard or lifeline (at any location). The strength of the line can be reduced by 50 percent or more if a knot is used. Therefore, a stronger lanyard or lifeline should be used to compensate for the knot, or the lanyard length should be reduced (or the tie-off location raised) to minimize free fall distance, or the lanyard or lifeline should be replaced by one which has an appropriately incorporated connector to eliminate the need for a knot.

(2) Tie-off around rough or sharp (e.g., "H" or "I" beams) surfaces. Sharp or rough surfaces can damage rope lines and this reduces strength of the system drastically. Such tie-offs should be avoided whenever possible. An alternate means should be used such as a snaphook/D-ring connection, a tie-off apparatus (steel cable tie-off), an effective padding of the surfaces, or an abrasion-resistant strap around the supporting member. If these alternative means of tie-off are not available, the employer should try to minimize the potential free fall distance.

(3) Knots. Sliding hitch knots should not be used except in emergency situations. The one-and-one sliding hitch knot should never be used because it is unreliable in stopping a fall. The two-and-two, or three-and-three knots (preferable) may be used in emergency situations; however, care should be taken to limit free fall distances because of reduced lifeline/lanyard strength. OSHA requires that a competent or qualified person inspect each knot in a lanyard or vertical lifeline to ensure it meets the strength requirements in § 1910.140.

(j) Horizontal lifelines. Horizontal lifelines, depending on their geometry and angle of sag, may be subjected to greater loads than the impact load imposed by an attached component. When the angle of horizontal lifeline sag is less than 30 degrees, the impact force imparted to the lifeline by an attached lanyard is greatly amplified. For example, with a sag angle of 15 degrees the force amplification is about 2:1, and at 5 degrees sag it is about 6:1. Depending on the angle of sag, and the line's elasticity, the strength

of the horizontal lifeline, and the anchorages to which it is attached should be increased a number of times over that of the lanyard. Extreme care should be taken in considering a horizontal lifeline for multiple tie-offs. If there are multiple tie-offs to a horizontal lifeline, and one employee falls, the movement of the falling employee and the horizontal lifeline during arrest of the fall may cause other employees to fall. Horizontal lifeline and anchorage strength should be increased for each additional employee to be tied-off. For these and other reasons, the systems using horizontal lifelines must be designed only by qualified persons. OSHA recommends testing installed lifelines and anchors prior to use. OSHA requires that horizontal lifelines are designed, installed and used under the supervision of a qualified person.

(k) Eye-bolts. It must be recognized that the strength of an eye-bolt is rated along the axis of the bolt, and that its strength is greatly reduced if the force is applied at right angles to this axis (in the direction of its shear strength). Care should also be exercised in selecting the proper diameter of the eye to avoid creating a roll-out hazard (accidental disengagement of the snaphook from the eye-bolt).

(l) Vertical lifeline considerations. As required by § 1910.140(c)(3), each employee must have a separate lifeline when the lifeline is vertical. If multiple tie-offs to a single lifeline are used, and one employee falls, the movement of the lifeline during the arrest of the fall may pull other employees' lanyards, causing them to fall as well.

(m) Snaphook and carabiner considerations. As required by § 1910.140(c)(10), the following connections must be avoided unless the locking snaphook or carabiner has been designed for them because they are conditions that can result in rollout:

- (1) Direct connection to webbing, rope, or a horizontal lifeline;
- (2) Two (or more) snaphooks or carabiners connected to one D-ring;
- (3) Two snaphooks or carabiners connected to each other;
- (4) Snaphooks or carabiners connected directly to webbing, rope, or wire rope; and
- (5) Improper dimensions of the D-ring, rebar, or other connection point in relation to the snaphook or carabiner dimensions which would allow the gate to be depressed by a turning motion.

(n) Free fall considerations. Employers and employees should always be aware that a system's maximum arresting force is evaluated under normal use conditions established by the manufacturer. OSHA requires that personal fall arrest systems be rigged so an employee cannot free fall in excess of 6 feet (1.8 m). Even a few additional feet of free fall can significantly increase the arresting force on the employee, possibly to the point of causing injury and possibly exceeding the strength of the system. Because of this, the free fall distance should be kept to a minimum, and, as required by § 1910.140(d)(2), must never be greater than 6 feet (1.8 m). To assure this, the tie-off attachment point to the lifeline or anchor should be located at or above the connection

point of the fall arrest equipment to the harness. (Otherwise, additional free fall distance is added to the length of the connecting means (*i.e.*, lanyard)). Tying off to the walking-working surface will often result in a free fall greater than 6 feet (1.8 m). For instance, if a 6-foot (1.8-m) lanyard is used, the total free fall distance will be the distance from the walking-working level to the harness connection plus the 6 feet (1.8 m) of lanyard.

(o) Elongation and deceleration distance considerations. During fall arrest, a lanyard will stretch or elongate, whereas activation of a deceleration device will result in a certain stopping distance. These distances should be available with the lanyard or device's instructions and must be added to the free fall distance to arrive at the total fall distance before an employee is fully stopped. The additional stopping distance may be significant if the lanyard or deceleration device is attached near or at the end of a long lifeline, which may itself add considerable distance due to its own elongation. As required by § 1910.140(d)(2), sufficient distance to allow for all of these factors must also be maintained between the employee and obstructions below, to prevent an injury due to impact before the system fully arrests the fall. In addition, a minimum of 12 feet (3.7 m) of lifeline should be allowed below the securing point of a rope-grab-type deceleration device, and the end terminated to prevent the device from sliding off the lifeline. Alternatively, the lifeline should extend to the ground or the next working level below. These measures are suggested to prevent the employee from inadvertently moving past the end of the lifeline and having the rope grab become disengaged from the lifeline.

(p) Obstruction considerations. In selecting a location for tie-off, employers and employees should consider obstructions in the potential fall path of the employee. Tie-offs that minimize the possibilities of exaggerated swinging should be considered.

Appendix D to Subpart I of Part 1910—Test Methods and Procedures for Personal Fall Protection Systems Non-Mandatory Guidelines

This appendix contains test methods for personal fall protection systems which may be used to determine if they meet the system performance criteria specified in paragraphs (d) and (e) of § 1910.140.

Test methods for personal fall arrest systems (paragraph (d) of § 1910.140).

(a) General. The following sets forth test procedures for personal fall arrest systems as defined in paragraph (d) of § 1910.140.

(b) General test conditions.

(1) Lifelines, lanyards and deceleration devices should be attached to an anchorage and connected to the body harness in the same manner as they would be when used to protect employees.

(2) The fixed anchorage should be rigid, and should not have a deflection greater than 0.04 inches (1 mm) when a force of 2,250 pounds (10 kN) is applied.

(3) The frequency response of the load measuring instrumentation should be 120 Hz.

(4) The test weight used in the strength and force tests should be a rigid, metal cylindrical or torso-shaped object with a girth of 38 inches plus or minus 4 inches (96 cm plus or minus 10 cm).

(5) The lanyard or lifeline used to create the free fall distance should be supplied with the system, or in its absence, the least elastic lanyard or lifeline available should be used with the system.

(6) The test weight for each test should be hoisted to the required level and should be quickly released without having any appreciable motion imparted to it.

(7) The system's performance should be evaluated, taking into account the range of environmental conditions for which it is designed to be used.

(8) Following the test, the system need not be capable of further operation.

(c) Strength test.

(1) During the testing of all systems, a test weight of 300 pounds plus or minus 3 pounds (136.4 kg plus or minus 1.4 kg) should be used. (See paragraph (b)(4) of this appendix.)

(2) The test consists of dropping the test weight once. A new unused system should be used for each test.

(3) For lanyard systems, the lanyard length should be 6 feet plus or minus 2 inches (1.83 m plus or minus 5 cm) as measured from the fixed anchorage to the attachment on the body harness.

(4) For rope-grab-type deceleration systems, the length of the lifeline above the centerline of the grabbing mechanism to the lifeline's anchorage point should not exceed 2 feet (0.61 m).

(5) For lanyard systems, for systems with deceleration devices which do not automatically limit free fall distance to 2 feet (0.61 m) or less, and for systems with deceleration devices which have a connection distance in excess of 1 foot (0.3 m) (measured between the centerline of the lifeline and the attachment point to the body harness), the test weight should be rigged to free fall a distance of 7.5 feet (2.3 m) from a point that is 1.5 feet (46 cm) above the anchorage point, to its hanging location (6 feet (1.83 m) below the anchorage). The test weight should fall without interference, obstruction, or hitting the floor or ground during the test. In some cases a non-elastic wire lanyard of sufficient length may need to be added to the system (for test purposes) to create the necessary free fall distance.

(6) For deceleration device systems with integral lifelines or lanyards that automatically limit free fall distance to 2 feet (0.61 m) or less, the test weight should be rigged to free fall a distance of 4 feet (1.22 m).

(7) Any weight that detaches from the harness should constitute failure for the strength test.

(d) Force test.

(1) General. The test consists of dropping the respective test weight specified in paragraph (d)(2)(i) or (d)(3)(i) of this appendix once. A new, unused system should be used for each test.

(2) For lanyard systems. (i) A test weight of 220 pounds plus or minus three pounds (100 kg plus or minus 1.6 kg) should be used. (See paragraph (b)(4) of this appendix.)

(ii) Lanyard length should be 6 feet plus or minus 2 inches (1.83 m plus or minus 5 cm) as measured from the fixed anchorage to the attachment on the body harness.

(iii) The test weight should fall free from the anchorage level to its hanging location (a total of 6 feet (1.83 m) free fall distance) without interference, obstruction, or hitting the floor or ground during the test.

(3) For all other systems. (i) A test weight of 220 pounds plus or minus 2 pounds (100 kg plus or minus 1.0 kg) should be used. (See paragraph (b)(4) of this appendix.)

(ii) The free fall distance to be used in the test should be the maximum fall distance physically permitted by the system during normal use conditions, up to a maximum free fall distance for the test weight of 6 feet (1.83 m), except as follows:

(A) For deceleration systems having a connection link or lanyard, the test weight should free fall a distance equal to the connection distance (measured between the centerline of the lifeline and the attachment point to the body harness).

(B) For deceleration device systems with integral lifelines or lanyards that automatically limit free fall distance to 2 feet (0.61 m) or less, the test weight should free fall a distance equal to that permitted by the system in normal use. (For example, to test a system with a self-retracting lifeline or lanyard, the test weight should be supported and the system allowed to retract the lifeline or lanyard as it would in normal use. The test weight would then be released and the force and deceleration distance measured).

(4) Failure. A system fails the force test when the recorded maximum arresting force exceeds 2,520 pounds (11.2 kN) when using a body harness.

(5) Distances. The maximum elongation and deceleration distance should be recorded during the force test.

(e) Deceleration device tests.

(1) General. The device should be evaluated or tested under the environmental conditions (such as rain, ice, grease, dirt, and type of lifeline) for which the device is designed.

(2) Rope-grab-type deceleration devices. (i) Devices should be moved on a lifeline 1,000 times over the same length of line a distance of not less than 1 foot (30.5 cm), and the mechanism should lock each time.

(ii) Unless the device is permanently marked to indicate the type of lifelines that must be used, several types (different diameters and different materials), of lifelines should be used to test the device.

(3) Other self-activating-type deceleration devices. The locking mechanisms of other self-activating-type deceleration devices designed for more than one arrest should lock each of 1,000 times as they would in normal service.

Test methods for positioning systems (paragraph (e) of § 1910.140).

(a) General. The following sets forth test procedures for positioning systems as defined in paragraph (e) of § 1910.140. The requirements in this appendix for personal fall arrest systems set forth procedures that may be used, along with the procedures listed below, to determine compliance with the requirements for positioning systems.

(b) Test conditions.

(1) The fixed anchorage should be rigid and should not have a deflection greater than 0.04 inches (1 mm) when a force of 2,250 pounds (10 kN) is applied.

(2) For window cleaners' belts, the complete belt should withstand a drop test consisting of a 250 pound (113 kg) weight falling free for a distance of 6 feet (1.83 m). The weight should be a rigid object with a girth of 38 inches plus or minus 4 inches (96 cm plus or minus 10 cm). The weight should be placed in the waistband with the belt buckle drawn firmly against the weight, as when the belt is worn by a window cleaner. One belt terminal should be attached to a rigid anchor and the other terminal should hang free. The terminals should be adjusted to their maximum span. The weight fastened in the freely suspended belt should then be lifted exactly 6 feet (1.83 m) above its "at rest" position and released so as to permit a free fall of 6 feet (1.83 m) vertically below the point of attachment of the terminal anchor. The belt system should be equipped with devices and instrumentation capable of measuring the duration and magnitude of the arrest forces. Failure of the test should consist of any breakage or slippage sufficient to permit the weight to fall free of the system. In addition, the initial and subsequent arresting forces should be measured and should not exceed 2,000 pounds (8.5 kN) for more than 2 milliseconds for the initial impact, or exceed 1,000 pounds (4.5 kN) for the remainder of the arrest time.

(3) All other positioning systems (except for restraint line systems) should withstand a drop test consisting of a 250 pound (113 kg) weight free falling a distance of 4 feet (1.2 m). The weight must be a rigid object with a girth of 38 inches plus or minus 4 inches (96 cm plus or minus 10 cm). The body belt or harness should be affixed to the test weight as it would be to an employee. The system should be connected to the rigid anchor in the manner that the system would be connected in normal use. The weight should be lifted exactly 4 feet (1.2 m) above its "at rest" position and released so as to permit a vertical free fall of 4 feet (1.2 m). Failure of the system should be indicated by any breakage or slippage sufficient to permit the weight to fall free to the ground.

Subpart N—[Amended]

■ 13. Revise the authority citation for subpart N to read as follows:

Authority: 29 U.S.C. 653, 655, 657; Secretary of Labor's Order No. 12-71 (36 FR 8754), 8-76 (41 FR 25059), 9-83 (48 FR 35736), 1-90 (55 FR 9033), 6-96 (62 FR 111), 3-2000 (65 FR 50017), 5-2002 (67 FR 65008), 5-2007 (72 FR 31159), 4-2010 (75 FR 55355), or 1-2012 (77 FR 3912), as applicable; and 29 CFR part 1911.

■ 14. In § 1910.178, revise paragraph (j) to read as follows:

§ 1910.178 Powered industrial trucks.

* * * * *

(j) *Dockboards (bridge plates)*. See subpart D of this part.

* * * * *

■ 15. In § 1910.179, revise paragraphs (c)(2), (d)(3), and (d)(4)(iii) to read as follows:

§ 1910.179 Overhead and gantry cranes.

* * * * *

(c) * * *

(2) *Access to crane*. Access to the car and/or bridge walkway shall be by a conveniently placed fixed ladder, stairs, or platform requiring no step over any gap exceeding 12 inches (30 cm). Fixed ladders must comply with subpart D of this part.

* * * * *

(d) * * *

(3) *Toeboards and handrails for footwalks*. Toeboards and handrails must comply with subpart D of this part.

(4) * * *

(iii) Ladders shall be permanently and securely fastened in place and constructed in compliance with subpart D of this part.

* * * * *

Subpart R—[Amended]

■ 16. Revise the authority citation for subpart R to read as follows:

Authority: 29 U.S.C. 653, 655, 657; Secretary of Labor's Order No. 12-71 (36 FR 8754), 8-76 (41 FR 25059), 9-83 (48 FR 35736), 1-90 (55 FR 9033), 6-96 (62 FR 111), 5-2007 (72 FR 31159), 4-2010 (75 FR 55355), or 1-2012 (77 FR 3912), as applicable; and 29 CFR part 1911.

■ 17. In § 1910.261, revise paragraphs (c)(15)(ii), (e)(4), (g)(2)(ii), (g)(13)(i), (h)(1), (j)(4)(iii), (j)(5)(i), (k)(6), (k)(13)(i) and (k)(15) to read as follows:

§ 1910.261 Pulp, paper, and paperboard mills.

* * * * *

(c) * * *

(15) * * *

(ii) Where conveyors cross passageways or roadways, a horizontal platform shall be provided under the conveyor, extended out from the sides of the conveyor a distance equal to 1½ times the length of the wood handled. The platform shall extend the width of the road plus 2 feet (61 cm) on each side, and shall be kept free of wood and rubbish. The edges of the platform shall be provided with toeboards or other protection that meet the requirements of subpart D of this part, to prevent wood from falling.

* * * * *

(e) * * *

(4) *Runway to the jack ladder*. The runway from the pond or unloading dock to the table shall be protected with standard handrails and toeboards. Inclined portions shall have cleats or equivalent nonslip surfacing that

complies with subpart D of this part. Protective equipment shall be provided for persons working over water.

* * * * *

(g) * * *

(2) * * *

(ii) The worker shall be provided with eye protection, a supplied air respirator and a personal fall protection system that meets the requirements of subpart I of this part, during inspection, repairs or maintenance of acid towers. The line shall be extended to an attendant stationed outside the tower opening.

* * * * *

(13) * * *

(i) Blow-pit openings preferably shall be on the side of the pit instead of on the top. Openings shall be as small as possible when located on top, and shall be protected in accordance with subpart D of this part.

* * * * *

(h) * * *

(1) *Bleaching engines.* Bleaching engines, except the Bellmer type, shall be completely covered on the top, with the exception of one small opening large enough to allow filling, but too small to admit an employee. Platforms leading from one engine to another shall have standard guardrails that meet the requirements in subpart D of this part.

* * * * *

(j) * * *

(4) * * *

(iii) When beaters are fed from the floor above, the chute opening, if less than 42 inches (1.06 m) from the floor, shall be provided with a guardrail system that meets the requirements in subpart D of this part, or other equivalent enclosures. Openings for manual feeding shall be sufficient only for entry of stock, and shall be provided with at least two permanently secured crossrails or other fall protection system that meet the requirements in subpart D.

* * * * *

(5) * * *

(i) All pulpers having the top or any other opening of a vessel less than 42 inches (107 cm) from the floor or work platform shall have such openings guarded by guardrail systems that meet the requirements in subpart D of this part, or other equivalent enclosures. For manual changing, openings shall be sufficient only to permit the entry of stock, and shall be provided with at least two permanently secured crossrails, or other fall protection systems that meet the requirements in subpart D.

* * * * *

(k) * * *

(6) *Steps.* Steps of uniform rise and tread with nonslip surfaces that meet the requirements in subpart D of this part shall be provided at each press.

* * * * *

(13) * * *

(i) A guardrail that complies with subpart D of this part shall be provided at broke holes.

* * * * *

(15) *Steps.* Steps or ladders that comply with subpart D of this part and tread with nonslip surfaces shall be provided at each calendar stack. Handrails and hand grips complying with subpart D shall be provided at each calendar stack.

* * * * *

■ 18. In § 1910.262, revise paragraph (r) to read as follows:

§ 1910.262 Textiles.

* * * * *

(r) *Gray and white bins.* On new installations guardrails that comply with subpart D of this part shall be provided where workers are required to plait by hand from the top of the bin so as to protect the worker from falling to a lower level.

* * * * *

■ 19. In § 1910.265, revise paragraphs (c)(4)(v), (c)(5)(i), and (f)(6) to read as follows:

§ 1910.265 Sawmills.

* * * * *

(c) * * *

(4) * * *

(v) *Elevated platforms.* Where elevated platforms are used routinely on a daily basis, they shall be equipped with stairways or fixed ladders that comply with subpart D of this part.

* * * * *

(5) * * *

(i) *Construction.* Stairways shall be constructed in accordance with subpart D of this part.

* * * * *

(f) * * *

(6) *Ladders.* A fixed ladder complying with the requirements of subpart D of this part, or other adequate means, shall be provided to permit access to the roof. Where controls and machinery are mounted on the roof, a permanent stairway with standard handrail shall be installed in accordance with the requirements in subpart D.

* * * * *

■ 20. In § 1910.268:

■ a. Revise paragraphs (g)(1);

■ b. Remove paragraph (g)(2);

■ c. Redesignate (g)(3) as (g)(2); and

■ d. Revise paragraph (h).

The revisions read as follows:

§ 1910.268 Telecommunications.

* * * * *

(g) *Personal climbing equipment*—(1)

General. A positioning system or a personal fall arrest system shall be provided and the employer shall ensure their use when work is performed at positions more than 4 feet (1.2 m) above the ground, on poles, and on towers, except as provided in paragraphs (n)(7) and (8) of this section. These systems shall meet the applicable requirements in subpart I of this part. The employer shall ensure that all climbing equipment is inspected before each day's use to determine that it is in safe working condition.

* * * * *

(h) *Ladders.* Ladders, step bolts, and manhole steps shall meet the applicable requirements in subpart D of this part.

* * * * *

■ 21. In § 1910.269, revise paragraphs (g)(2)(i), (g)(2)(iv)(B), and (g)(2)(iv)(C)(1) to read as follows:

§ 1910.269 Electric power generation, transmission, and distribution.

* * * * *

(g) * * *

(2) * * *

(i) Personal fall arrest systems shall meet the requirements of subpart I of this part.

* * * * *

(iv) * * *

(B) Personal fall arrest systems shall be used in accordance with subpart I of this part.

Note to paragraph (g)(2)(iv)(B): Fall protection equipment rigged to arrest falls is considered a fall arrest system and must meet the applicable requirements for the design and use of those systems. Fall protection equipment rigged for work positioning is considered work-positioning equipment and must meet the applicable requirements for the design and use of that equipment.

(C) * * *

(1) Each employee working from an aerial lift shall use a travel restraint system or a personal fall arrest system.

* * * * *