

## Subchapter 1. Unfired Pressure Vessel Safety Orders

---

### Article 1. Scope of these Orders

---

#### §450. Application of the Unfired Pressure Vessel Safety Orders.

---

(a) These Orders apply to places of employment in California, and establish minimum standards for:

(1) The design, construction, and installation of LP-Gas containers, including the storage and handling of LP-Gas. National Fire Protection Association (NFPA) 58, LP-Gas Code, ~~1998~~ 2020 Edition, is hereby incorporated by reference. Supplementing NFPA 58 are these Safety Orders, beginning with Sections 470 through 494, which are determined necessary for the protection of the safety and health of employees.

(2) The design and construction of all other non-LP-Gas unfired pressure vessels.

(3) The installation, use, repair, and alteration of air tanks, LP-Gas and NH<sub>3</sub> tanks and systems.

(4) The inspection of and issuance of permits to operate for air and LP-Gas tanks.

(5) The design, construction, installation, use, repair, and alteration of pressure vessels for the storage and dispensing of natural gas as a motor fuel, except in vehicles that are licensed to travel on highways. National Fire Protection Association (NFPA) 52, Vehicular Gaseous Fuel Code, 2023 Edition, is hereby incorporated by reference. Supplementing NFPA 52 are these Safety Orders, found in Article 7, which are determined necessary for the protection of the safety and health of employees.

(6) The design, construction, repair and alteration of LNG, ~~LP~~LP-Gas and NH<sub>3</sub> storage tanks for operation at 15 psig or less.

(b) After the date on which these Orders become effective, all installations and equipment shall conform to these Orders, except as noted in Section 451.

EXCEPTION: Existing installations and equipment which were and remain in compliance with the Safety Orders, or variances therefrom, in effect at the time of manufacture or installation.

(c) When any provision of these Safety Orders conflicts with NFPA 58 and is more stringent than the corresponding Section of NFPA 58, the Safety Order shall take precedence.

#### Credits

NOTE: Authority cited: Section 142.3 Labor Code; and Section 13241, Health and Safety Code.  
Reference: Section 142.3, Labor Code.

## HISTORY

1. Repealer of Subchapter 1 and new Subchapter 1 (T8-450 through T8-467, 470 through T8-485, 488 through 494, T8-500 through T8-513, and T8-550) filed 7-17-70; effective thirtieth day thereafter (Register 70, No. 29). Approved by State Building Standards Commission 6-26-70. For prior history, see Registers 58, No. 38; 64, No. 9; and 68, No. 38.
2. Amendment filed 12-8-72 as procedural and organizational; effective upon filing (Register 72, No. 50).
3. Amendment of subsection (a) filed 3-29-74; effective thirtieth day thereafter (Register 74, No. 13).
4. Repealer of subsection (b) and new subsection (b) filed 8-6-76; effective thirtieth day thereafter (Register 76, No. 32).
5. Amendment of subsection (b) filed 7-6-79 as procedural and organizational; effective upon filing (Register 79, No. 27).
6. New subsection (a)(6) filed 1-17-80; effective thirtieth day thereafter (Register 80, No. 3).
7. Amendment filed 1-5-88; operative 2-4-88 (Register 88, No. 4).
8. Amendment of section and NOTE filed 12-4-96; operative 1-3-97 (Register 96, No. 49).
9. Amendment of subsections (a)(1) and (a)(6)-(c) filed 1-30-2002; operative 3-1-2002 (Register 2002, No. 5).

### **§451. Unfired Pressure Vessels Not Subject to These Safety Orders.**

---

(a) Pressure vessels that are under the jurisdiction and inspection of the United States Government or are specifically exempted by the Labor Code.

(b) Pressure vessels subject to an internal or external pressure of not more than 15 psig except for those listed in Section 450(a)(5), with no limitation on size, and vessels having an inside diameter not exceeding 6 inches with no limitation on pressure. However, vessels excluded in this section shall be designed and constructed in accordance with recognized standards when applicable, or in accordance with good engineering practices for pressure vessel design using a ~~factor of safety~~ design margin of the specified minimum tensile strength divided by the design pressure of at least ~~4~~ 3.5, and shall be fitted with necessary controls and safety devices to permit safe operation.

(c) Natural gas vessels and installations and air brake tanks subject to the jurisdiction and inspection of the Public Utilities Commission, the Department of Transportation, or the Department of the California Highway Patrol, except as provided in Article 7 of these Orders.

### **Credits**

NOTE: Authority cited: Section 142.3, Labor Code. Reference: Sections 142.3 and 7624, Labor Code; and Section 13241, Health and Safety Code.

#### HISTORY

1. Amendment filed 12-8-72 as procedural and organizational; effective upon filing (Register 72, No. 50).
2. Amendment of subsection (c) filed 3-29-74; effective thirtieth day thereafter (Register 74, No. 13).
3. Amendment of subsection (b) filed 1-17-80; effective thirtieth day thereafter (Register 80, No. 3).
4. Amendment filed 1-5-88; operative 2-4-88 (Register 88, No. 4).
5. Amendment of NOTE filed 12-4-96; operative 1-3-97 (Register 96, No. 49).
6. Amendment of subsection (c) filed 9-25-2002 as an emergency; operative 9-25-2002 (Register 2002, No. 39). A Certificate of Compliance must be transmitted to OAL by 1-23-2003 or emergency language will be repealed by operation of law on the following day.
7. Certificate of Compliance as to 9-25-2002 order, including further amendment of subsection (c), transmitted to OAL 1-17-2003 and filed 2-24-2003 (Register 2003, No. 9).

#### **§452. Variances. (Repealed)**

---

#### **Credits**

NOTE: Authority cited: Section 142.3, Labor Code. Reference: Section 142.3, Labor Code.

1. Repealer and new section filed 8-6-76; effective thirtieth day thereafter (Register 76, No. 32).
2. Repealer filed 1-5-88; operative 2-4-88 (Register 88, No. 4).

#### **§453. Definitions**

---

The following definitions shall apply in the application and interpretation of these Orders.

For definitions directly relevant to LP-Gas, see ~~1998~~ 2020 Edition of NFPA 58, Section ~~4-6~~ 3.

49 CFR: Title 49, Code of Federal Regulations, Parts 100-199.

Acceptable: Capable of performing the particular function specified in the Order with safety.

Air Brake Tank: An air tank 10 inches or less in diameter, having a capacity of 1 1/2 cubic feet or less, and operating at 150 psig or less, and used exclusively to supply air to the braking systems of automotive vehicles and other air-operated auxiliaries used in the operation of such vehicles. The 150 psig limitation need not apply to tanks less than 6 inches in inside diameter.

Air Tank: A pressure vessel used for the storage or accumulation of air under pressure. This definition is not intended to include utilization equipment, including such devices as grease tanks, fire extinguishers, paint sprayers, etc., where the tank is partly filled with a product and the air pressure is used only for a cushion or to eject the product from the tank, or such devices as strainers, scrubbers, separators, etc., that are a part of the piping system.

Alteration: A change in ~~any~~ the item described on the original Manufacturer's Data Report which affects the pressure containing capability of the pressure ~~vessel~~ retaining item. Nonphysical changes such as an increase in the maximum allowable working pressure (internal or external), increase in design temperature, or a reduction in minimum temperature of a pressure-retaining item shall be considered an alteration.

ANSI Standards: Standards approved by the American National Standards Institute, Inc.

~~(A) Chemical Plant and Petroleum Refinery Piping, ANSI B31.3 (except non-metallic pipe such as plastic is not acceptable unless permitted by specific safety orders).~~

~~(B) Refrigeration Piping, ANSI B31.5.~~

API Standard 620: API Standard 620 12<sup>th</sup> Edition, October 2013, Addendum 1, 2014 -Design and Construction of Large, Welded, Low-Pressure Storage Tanks

Applicator Tank: A service tank used in agriculture for applying anhydrous ammonia to the soil, or for other agricultural uses.

Approved: See Section 3206, General Industry Safety Order.

Appurtenance: A device installed on and used in the normal operation of the vessel. This includes, but is not limited to, safety relief devices, liquid level gauging devices, valves, and pressure gauges.

Artificial Heat: Any heat other than solar or atmospheric heat.

ASME Certificate Holder: A Company with valid Certificate(s) of Authorization to manufacture new boilers or pressure vessels.

ASME Code: The American Society of Mechanical Engineers' Boiler and Pressure Vessel Code, 2023 Edition.

~~(1) Power Boilers, Section I.~~

- ~~(2) Materials Specifications, Section II.~~
- ~~(3) Nuclear Power Plant Components, Section III, Division 1 and 2.~~
- ~~(4) Heating Boilers, Section IV.~~
- ~~(5) Non-destructive Examination, Section V.~~
- ~~(6) Recommended Rules for Care and Operation of Heating Boilers, Section VI.~~
- ~~(7) Recommended Rules for Care of Power Boilers, Section VII.~~
- ~~(8) Pressure Vessels, Section VIII, Division 1 and 2.~~
- ~~(9) Welding and Brazing Qualifications, Section IX.~~
- ~~(10) Fiberglass-Reinforced Plastic Pressure Vessels, Section X.~~
- ~~(11) Rules for Inservice Inspection of Nuclear Power Plant Components, Section XI.~~
- ~~(12) Power Piping, ASME B31.1 (except non-metallic pipe such as plastic is not acceptable unless permitted by specific safety orders).~~
- ~~(13) Pressure Vessel for Human Occupancy (PVHO), Safety Standard for Pressure Vessels for Human Occupancy.~~

ASME B31.1: ASME B31.1-2022 Power Piping code

ASME B31.3: ASME B31.3-2022 Process Piping code

ASME B31.5: ASME B31.5-2022 Refrigeration and Heat Transfer Components code

ASME B31.8: ASME B31.8-2022 Gas Transmission and Distribution Piping Systems code

ASME PVHO Standard: Safety Standard for Pressure Vessels for Human Occupancy, PVHO-1-2019

ASTM: American Society for Testing Materials.

Brittle Failure: A pipe failure mode which exhibits no visible (to the naked eye) material deformation (stretching, elongation, or necking down) in the area of the break.

Bulk Plant: NH<sub>3</sub>, CNG, LP-Gas and LNG: An installation other than a dispensing unit, used to store the product for further transfer.

Bulk Storage: Storage in vessels other than DOT cylinders.

California Standard Tank: A tank built in accordance with the requirements for California standard tanks as set forth in the Air Pressure Tank Safety Orders in force at the time the tank was constructed.

Capacity: The gross capacity of a pressure vessel in U.S. Gallons. See "Water Capacity."

Certificate of Competency: Certification issued by the Division to persons who have satisfactorily passed the written boiler and pressure vessel inspector's examination prescribed by the Division.

Certificate of Resale Inspection: A certificate issued after a resale inspection and designating the maximum allowable working pressure for the tank when it is installed in compliance with these Orders. This certificate is not a permit to operate. This certificate shall expire not more than 5 years from date of inspection or when the tank is returned to service, whichever occurs first.

Certified Inspector: A person ~~holding a valid certificate of competency issued by the Division in accordance with~~ certified in accordance with Section 779 of the Boiler and Fired Pressure Vessel Safety Orders.

CNG: Compressed natural gas. Natural gas that has been compressed for storage in containers.

~~Container Assembly: An assembly consisting essentially of the container and fittings for all container openings, including shutoff valves, excess flow valves, liquid level gauging devices, safety relief devices, and protective housing.~~

Container: Any vessel, including tanks, cylinders, tubes, portable tanks and cargo tanks, used for transporting or storing any liquid or gas.

~~Dike: A concrete, metal, or compacted earth structure used to confine an accidental spill within an impounding area.~~

Dispensing Unit:

(A) LP-Gas: Fixed equipment in which LP-Gas is stored and dispensed into portable containers.

(B) Natural Gas: A stationary natural gas installation other than a bulk plant from which CNG or LNG is dispensed into fuel tanks or portable cylinders from a storage tank, bank of cylinders, compressor, or a distribution gas pipeline.

Division: The Division of Occupational Safety and Health, Department of Industrial Relations, State of California.

DOT Service: Service in which a pressure vessel is used, inspected and maintained in accordance with DOT regulations.

DOT Specifications: Regulations of the Federal Department of Transportation published in 49 CFR Parts 100-199.

Ductile Failure: A pipe material failure mode which exhibits ~~material~~ appreciable plastic deformation (stretching, elongation, or necking down) in the area of the break.

Ductile Plastic Materials: Plastic materials able to withstand external impact from both blunt and sharp objects, while charged with compressed gas under the full rated pressure of the piping system, without brittle failure.

Existing Installations: All pressure vessels installed in California prior to the adoption date of these Orders and in compliance with applicable Safety Orders of the Division in effect at that time and that have not changed ownership and location since the adoption date of these Orders.

External Inspection: An inspection of all visible external surfaces and appurtenances of an installed pressure vessel.

Farm Cart: A vehicle for use on a farm on which is mounted a container of not over 1,200 gallons water capacity.

Field Inspection: An internal and/or external inspection of installed pressure vessels.

Fill, Filling:

(A) Filled by Pressure: A means of filling a ~~pressure vessel~~ tank or cylinder whereby the quantity of compressed gas in the vessel at normal temperature is determined by a pressure gauge or gauges.

(B) Filled by Volume: A means of filling a tank or cylinder whereby the volume of liquid in the vessel is determined by measuring the liquid level.

(C) Filled by Weight: A means of filling a tank or cylinder whereby the amount of the product in the vessel is determined by weight.

Flammable Gas: A flammable gas is one with either of the following properties:

(A) At atmospheric pressure and temperature forms a flammable mixture with air when present at a concentration of 13 percent or less (by volume) or which forms a range of flammable mixtures with air wider than 12 percent regardless of the lower limit, or

(B) projects a flame more than 18 inches beyond the ignition source with valve opened fully, or the flame flashes back and burns at the valve with any degree of valve opening, when tested in the Bureau of Explosives' Flame Projection Apparatus.

Flammable Liquid: A flammable liquid is one that has a flash point above 20 degrees Fahrenheit to and including 80 degrees Fahrenheit as determined by Tagliabue's Open-Cup-Method. When the flash point is 20 degrees Fahrenheit or less it is termed an Extremely Flammable Liquid.

Gas: A form of matter having extreme molecular mobility and capable of diffusing and expanding rapidly in all directions.

Gas-Air Mixer: A device, or system of piping and controls, which mixes LNG vapor with air to produce a mixed gas of a lower heating value than the LNG.

GISO: Title 8, California Code of Regulations, Chapter 4, Subchapter 7, The General Industry Safety Orders.

Hazardous: A substance or circumstance which by reason of being explosive, flammable, poisonous, corrosive, oxidizing, or otherwise harmful is likely to cause injury. See GISO Article 109 for additional detail.

Important Building: A building in which there may be a source of ignition under normal operating conditions. A building is also considered an important building if any of the following criteria applies:

(A) The building is interned for human occupancy.

(B) The building or its contents are of high value.

(C) The building is important to emergency responders in a fire situation.

(D) The building has electrical wiring.

~~Impounding Area: An area used to contain an accidental liquid spill through the use of dikes and/or topography.~~

Installation:

(A) CNG and LNG: Includes natural gas pressure vessels, liquefiers, pumps, compressors and all attached valves, piping and appurtenances affecting the safety of the employment or place of employment. When filling directly from distribution lines by means of a compressor, the installation includes the compressor and all piping and piping components beyond the shutoff valve between the distribution system and the compressor.

(B) NH<sub>3</sub>: Includes the pressure vessel and all attached valves and other appurtenances affecting the safety of the employment or place of employment.

Labeled: See "Approved."

Listed: See "Approved."

LNG: Liquefied Natural Gas. A fluid in the liquid state composed predominantly of methane and which may contain minor quantities of ethane, propane, nitrogen, or other components normally found in natural gas and in a cryogenic state.

LP-Gas: Any material having a vapor pressure not exceeding that allowed for commercial propane that is composed predominantly of the following hydrocarbons, either by themselves (except propylene) or as mixtures; propane, propylene, butane (normal butane or isobutene), and butylenes.



**Maximum Allowable Working Pressure:** The pressure for which a ~~tank~~ pressure vessel was constructed, or if conditions have changed, the maximum pressure permitted at the last inspection by a certified inspector or qualified safety engineer.

~~Maximum Filling Density: The percent ratio of the weight of gas in the tank to the weight of water that the tank will hold. For determining the water capacity of the tank in pounds, the weight of a gallon (231 cubic inches) of water at 60 degrees Fahrenheit in air shall be 8.32828 pounds.~~

**Metallic Hose:** A hose in which the strength of the hose depends primarily upon the strength of metallic parts but it may have non-metallic liners and/or covers.

**Mobile Fuel Tank:** A vessel mounted on a vehicle or other readily portable device and used only to supply fuel to an internal-combustion engine or other equipment secured to the vehicle or device.

~~Mobile Storage Module: Assembly of a multiple number of tubes securely fastened within a framework structure and used in DOT service.~~

**Mobile Storage Tank, MST:** A tank installed on a trailer or semitrailer, and used temporarily to receive and store anhydrous ammonia. "Temporarily" means not more than 120 days.

**Motor Fuel Tank:** See Mobile Fuel Tank.

**Natural Gas:** Naturally occurring mixtures of hydrocarbon gases and vapors consisting principally of methane, either in gaseous or liquid form.

**New Installations:** All pressure vessels, other than existing installations, installed or reinstalled in a new location after the effective date of these Orders

**NBIC: The National Board Inspection Code, 2023 Edition, published by the National Board of Boiler and Pressure Vessel Inspectors.**

**NFPA: National Fire Protection Association**

**(1) NFPA 52 – Vehicular Natural Gas Fuel System Code, 2023 Edition**

**(2) NFPA 58 – Liquefied Petroleum Gas Code, 2020 Edition**

**(3) NFPA 59A – Standard for the Production, Storage, and Handling of Liquefied Natural Gas (LNG), 2023 Edition**

**NH<sub>3</sub>:** The chemical notation of anhydrous ammonia, a chemical compound composed of nitrogen and hydrogen. It is normally stored and transported as a liquid under pressure. However, in some large storage facilities it is refrigerated and stored at atmospheric pressure.

**Nurse Tank:** A tank used in agriculture for off-highway service to deliver NH<sub>3</sub> from a transportation tank or storage tank to an applicator tank in the field.

~~Outage: That~~ The space required to be left in the vessel to provide for expansion of the liquid by an increase of temperature. For LNG outage is that space required to be left in vessels filled by volume to provide for separation of the vapors resulting from boil-off of the liquid and also to provide for the expansion of the liquid with increase of temperature.

Poison: A substance which when taken in small quantities or low concentrations by mouth, inhaled, or absorbed through the skin rapidly jeopardizes life by other than mechanical or physical action.

Portable Air Tank: An air tank mounted with an air compressor on a towed vehicle.

Portable LNG Tank: A service tank not exceeding 2,000-gallon water capacity used to transport LNG.

Portable NH<sub>3</sub> Tank: A service tank not exceeding 1200-gallons capacity used to transport anhydrous ammonia.

Pressure Retaining Item (PRI): Any boiler, pressure vessel, piping, or material used for the containment of pressure, either internal or external.

Pressure Vessel: An unfired container, including cylinders, used for the storage or accumulation of any gas or liquid under pressure. This definition is not intended to include pressure chambers that are integral parts of such devices as pumps, motors, engines, clothes presses, flatwork ironers, tire molds, etc., where the pressure-containing part is subjected to severe mechanical stresses.

Property Line: A line, imaginary or otherwise, separating a property from adjoining property of public or private ownership.

Pull Away Device: A device installed and anchored so that any tension exceeding the manufacturer's rating on the hose will cause the device to separate and prevent the LP-Gas to escape from both the upstream and downstream lines.

Qualified Person, Attendant, or Operator- A person designated by an employer who by reason of training and experience has demonstrated the ability to safely perform his/her duties and, where required, is properly licensed in accordance with federal, state or local laws and regulations. Reference G.I.S.O. 3207.

Qualified Inspector: Either a certified inspector or a qualified safety engineer. ~~Qualified Safety Engineer: A person who is qualified to make inspections or examinations of boilers or tanks according to the rules under which the vessel was constructed, and who holds a valid certificate of competency issued by the Division.~~

Qualified Safety Engineer: A Division Employee who is qualified to make inspections or examinations of boilers or tanks according to the rules under which the vessel was constructed, and who holds a valid certificate of competency issued by the Division.

Quality Control System: A written program maintained and implemented by employers containing procedures to ensure that the manufacture, repair, alteration, or replacement of items covered by these safety orders is done in accordance with the requirements of the NBIC and/or ASME Codes.

Receiving Vessel: A tank or cylinder into which a product is being charged.

Repair Organization: An organization accredited for the scope of activities by The National Board, and in possession of a valid "R" symbol stamp, which performs repairs and or alterations to boilers or pressure vessels.

NOTE: A repair organization can also be an ASME Certificate Holder, if they originally constructed the vessel being repaired and have a Quality Control System that covers repairs.

Resale Inspection: The inspection of any used vessel to determine its allowable working pressure when reinstalled in accordance with these Orders.

Respiratory Protective Device (RPD): A breathing device designed to protect the wearer from a hazardous atmosphere.

SAE: Society of Automotive Engineers.

Second-hand Pressure Vessel: A used pressure vessel that has changed both ownership and location.

Service Valve: A valve connected directly to a vessel outlet not larger than 3/4-inch pipe size and having an inlet diameter not exceeding the internal diameter of 1/2-inch Schedule 80 pipe for applications other than LP-Gas.

Shop Inspection: Inspection of tanks in a fabricator's shop, or at the job site during ~~erection~~ construction, as required by the ASME Code, or as required by the NBIC for repair/alteration activities.

Standard Dimension Ratios (SDR): A specific ratio of the average specified outside diameter to the minimum specified wall thickness (Do/t) for outside diameter-controlled plastic pipe, the value of which is derived by adding one to the pertinent number selected from the ANSI Preferred Number Series 10 contained in American Society for Testing and Materials (ASTM) Designation No. F412-87a (1987), Standard Definitions of Terms Relating to Plastic Piping Systems which is herein incorporated by reference.

Storage Tank: A tank permanently located and used to store a product or to supply a product to utilization equipment.

Suitable: See "Acceptable."

Surge Tank: See "Gas-Air Mixer."

Systems: An assembly of equipment and appurtenances consisting essentially of the container or containers, major devices such as vaporizers, safety relief valves, excess flow valves, regulators, and connecting piping.

Tank: A container, other than a cylinder in DOT service, used for the storage or accumulation of any liquid or gas under pressure. This definition is not intended to include pressure chambers that are

integral parts of such devices as pumps, motors, engines, clothes presses, flatwork ironers, tire molds, etc., where the pressure-containing part is subjected to severe mechanical stresses.

Transportation Tank: A tank permanently installed on a truck, trailer, or semi-trailer used to transport a product over the highway.

Trap Tank (Trap Wagon): A tank mounted on wheels for off-highway use and having a capacity of 1200 gallons or less and used to transport LP-Gas from a storage tank to a mobile fuel tank.

Tube: A hollow product of round or any other cross-section having a continuous periphery.

NOTE: For CNG service, a tube is a seamless, cylindrical-shaped pressure container used in DOT service such as transport trailers.

UM: Unfired Miniature, as Defined in ASME Code ~~Section VIII, Division 1.~~

Vapor Pressure: The pressure of the vapor (psig) in equilibrium with the liquid at a temperature of 100 degrees Fahrenheit.

~~Vaporizers:~~

Vaporizer: A device used to convert LNG or LP-Gas from the liquid to the gaseous state by means of artificial or atmospheric heat.

~~LNG Vaporizer: A device used to convert LNG from the liquid to the gaseous state by means of artificial or atmospheric heat.~~

Ventilation-Adequate: When specified for the prevention of fire during normal operation, ventilation shall be considered adequate when the concentration of the gas in a gas-air mixture does not exceed 25 percent of the lower flammable limit.

Volumetric Filling: The amount of water, in either lb. or gal., at 60oF (15.6oC) required to fill a container full of water.

~~Weight Filling: See "Filled by Weight."~~

WOG: Water, oil, or gas rating (as applied to valves and fittings).

## **Credits**

NOTE: Authority cited: Section 142.3, Labor Code. Reference: Sections 142.3 and 7622, Labor Code; and Section 13241, Health and Safety Code.

## **HISTORY**

1. Amendment filed 12-8-72 as procedural and organizational; effective upon filing (Register 72, No. 50).

2. Amendment filed 3-28-75; effective thirtieth day thereafter (Register 75, No. 13).
3. Amendment filed 11-7-75; effective thirtieth day thereafter (Register 75, No. 45).
4. Amendment filed 12-14-76; effective thirtieth day thereafter (Register 76, No. 51).
5. Amendment filed 6-15-79; effective thirtieth day thereafter (Register 79, No. 24).
6. Amendment filed 10-18-79; effective thirtieth day thereafter (Register 79, No. 42).
7. Amendment of subsection (a) filed 4-13-82; effective thirtieth day thereafter (Register 82, No. 16).
8. Amendment filed 1-5-88; operative 2-4-88 (Register 88, No. 4).
9. Amendment filed 2-15-90; operative 3-17-90 (Register 90, No. 8).
10. New definitions for "Brittle Failure," "Ductile Failure," "Ductile Plastic Materials" and "Standard Dimension Ratios" filed 4-8-92; operative 5-8-92 (Register 92, No. 18).
11. Amendment of section and NOTE filed 12-4-96; operative 1-3-97 (Register 96, No. 49).
12. Amendment of first two paragraphs filed 1-30-2002; operative 3-1-2002 (Register 2002, No. 5).

## **Article 2. Design, and Construction, Repairs, and Alterations**

---

### **§454. Design and Construction of Air Tanks.**

---

(a) Except as permitted in Section 454(b) all air tanks for new installations shall be constructed, inspected and stamped in compliance with the ASME Code (unless the design, material, and construction of the air tank are accepted by the Division as equivalent to the ASME Code) and, ~~except for "UM" vessels,~~ registered with the National Board of Boiler and Pressure Vessel Inspectors. The stamping on all new air tanks or on nameplates attached thereto shall show the head and shell thickness in addition to the stamping required by the ASME Code.

(b) Air tanks used for self-contained breathing apparatus may be constructed in accordance with the ASME Code or DOT specifications provided they are inspected and maintained as required by DOT specifications and do not exceed a volumetric capacity of 1 cubic foot.

(c) The allowable working pressure of any existing air tank shall be determined by the provisions of the ASME Code effective when the tank was manufactured and upon its condition; provided, however, that

tanks constructed to other than ASME Code standards for air pressure service shall be calculated with a factor of safety of not less than 5.

(d) Air brake tanks shall be constructed in accordance with the ASME Code or SAE standard J-10b, 1981 Edition.

### **Credits**

NOTE: Authority cited: Section 142.3, Labor Code. Reference: Section 142.3, Labor Code.

### **HISTORY**

1. Amendment filed 12-8-72 as procedural and organizational; effective upon filing (Register 72, No. 50).
2. Amendment of subsection (a) filed 4-1-77; effective thirtieth day thereafter (Register 77, No. 14).
3. Amendment filed 1-5-88; operative 2-4-88 (Register 88, No. 4).

### **§455. Design and Construction of LPG, CNG and LNG Tanks.**

---

(a) All CNG and LNG tanks for new installations over 15 psig shall be constructed, inspected, and stamped in compliance with the ASME Code (unless the design, material, and construction of the tank are accepted by the Division as equivalent to the ASME Code) and, ~~except for "UM" vessels,~~ registered with the National Board of Boiler and Pressure Vessel Inspectors. The stamping on all new tanks or on nameplates attached thereto shall include, in addition to the stamping required by the ASME Code or the National Board of Boiler and Pressure Vessel Inspectors, the following:

#### (1) LPG Tanks:

(A) Additional container marking as required by NFPA 58.

#### (12) CNG Tanks:

(A) The volumetric capacity in standard cubic feet of natural gas when filled to the limits provided by these regulations.

(B) The words "For CNG."

(C) The head and shell thicknesses.

#### (23) LNG Tanks:

(A) The net volumetric capacity in U.S. Gallons.

(B) The words "for LNG."

(C) The head and shell thicknesses.

(D) The minimum safety relief valve capacity in CFM air. ~~(See 541(c)(1) and (2)).~~

(b) Tanks of brazed construction are prohibited.

(c) The outer shell of a double wall cryogenic vessel shall be designed for the full range of pressure and/or vacuum to which it will be subjected, and provide for adequate structural support of the inner tank and insulation under all imposed loadings.

(d) Welding to the shell, head, or any other part of the container subject to internal pressure, shall be done in compliance with the ASME Code under which the tank was fabricated. Other welding is permitted only on saddle plates, lugs, or brackets attached to the container by the tank manufacturer.

(e) All LNG tanks for new installations for low temperature storage at 15 psig or less, shall, ~~at~~ a minimum, be designed, constructed, inspected, and certified in accordance with API "Standard 620, Recommended Rules for Design and Construction of Large, Welded, Low Pressure Storage Tanks" and the following additional requirements which will supersede where there is any conflict, or to the ASME Code.

~~NOTE: The references following in parentheses refer to specific paragraphs in API 620, 1978 2013 Edition, Addendum 1 November 2014.~~

(1) The edges of the weld shall merge smoothly with the surface of the plate without a sharp angle. In making fillet welds, the weld metal shall be deposited in such a way that adequate penetration into the base metal at the root of the weld is secured. ~~Although the provisions of 4.13 apply for horizontal butt joints, visible undercuts are not permitted for vertical butt joints. (4.13)~~

(2) The inspector shall have a valid certificate of competency issued by the Division. ~~(5.02.1)~~

(3) The manufacturer shall have, and demonstrate, a quality control system to establish that all requirements including material, design, fabrication, examination (by manufacturer) and inspection (by the inspector) will be met. The written description of the quality control system shall, as a minimum, be in accordance with ~~Appendix 10 of the ASME Code, Section VIII, Division 1. (5.02.3)~~

(4) Safety relief device and relieving capacities shall be sized in accordance with NFPA 59A, NFPA Pamphlet NFPA 59A and Appendix A, 1978 Edition.

(5) The manufacturer's report, or attachments, shall show for inner and outer tanks as a minimum:

(A) Manufacturer's name.

(B) Manufacturer's serial number for the tank.

(C) Nominal capacity.

(D) Design pressure for vapor space at the top.

(E) Design temperature.

(F) Maximum permissible specific gravity of liquid contents to be stored.

(G) Maximum level to which the tank may be filled with liquid of that gravity, with full design pressure above the surfaces.

(H) Maximum level to which the tank may be filled with water for test or for purging purposes.

(I) Shell, head and other pressure boundary materials.

(J) Material thicknesses.

(K) Support and attachment materials.

(L) Nozzles, number and diameter.

(M) Year ~~built~~ completed. ~~(5-27-2)~~

(6) The openings and/or connections between the tank and the pressure relief devices shall have an area at least equal to the combined areas of all the pressure relief inlets on that connection. The size of any discharge line shall be such that any pressure that may exist or develop will not reduce the relief capacity of the relieving devices below that required to properly protect the vessel. ~~(N-3)~~

Where stop valves are used between the pressure relief devices and the tank, a written procedure shall be used to govern the use of the valves. Remote indicators shall be provided that will alert operating personnel when the stop valves are not in the fully open position or, alternately, reliable interlocks shall be provided to assure that minimum required relief capacity is always available. ~~(N-8)~~

(7) Design calculations shall be certified to be correct and complete by one or more currently registered professional engineers competent in the applicable field of design of LNG storage. The provisions of NFPA Pamphlet 59A, 1975, ~~Section 4-1.3~~ shall be used for seismic loadings. For public utilities, the provisions of General Order 112(D) of the California Public Utilities Commission shall also be considered for all live loadings including Part III, Subpart B, Sections 193.115, 117 and 119, for seismic loadings, and shall be acceptable to the Commission.

(8) When butt joints are used in outer tanks, they shall be double welded and designed with a joint efficiency of 70% as a minimum in accordance with table UW-12 of ASME Section VIII, Division 1. ~~(Q-6)~~

## Credits

NOTE: Authority cited: Section 142.3, Labor Code. Reference: Section 142.3, Labor Code; and Section 13241, Health and Safety Code.

## HISTORY



1. Amendment filed 12-8-72 as procedural and organizational; effective upon filing (Register 72, No. 50).
2. Amendment filed 11-7-75; effective thirtieth day thereafter (Register 75, No. 45).
3. Amendment of subsection (a) filed 4-1-77; effective thirtieth day thereafter (Register 77, No. 14).
4. Repealer of subsection (e) filed 4-7-81 as an emergency; effective upon filing (Register 81, No. 15). A Certificate of Compliance must be transmitted to OAL within 120 days or emergency language will be repealed on 8-5-81.
5. Certificate of Compliance transmitted to OAL 7-7-81 and filed 8-6-81 (Register 81, No. 32).
6. Amendment of subsections (a) - (g), and renumbering of Section 459 to subsection (h) filed 1-5-88; operative 2-4-88 (Register 88, No. 4).
7. Amendment of section heading, section and NOTE filed 12-4-96; operative 1-3-97 (Register 96, No. 49).

#### **§456. Design and Construction of CNG Cylinders.**

---

All CNG cylinders shall be constructed according to DOT specifications.

#### **Credits**

NOTE: Authority cited: Section 142.3, Labor Code. Reference: Section 142.3, Labor Code; and Section 13241, Health and Safety Code.

#### **HISTORY**

1. Amendment filed 12-8-72 as procedural and organizational; effective upon filing (Register 72, No. 50).
2. Amendment filed 11-7-75; effective thirtieth day thereafter (Register 75, No. 45).
3. Amendment filed 1-5-88; operative 2-4-88 (Register 88, No. 4).
4. Amendment of section heading, section and NOTE filed 12-4-96; operative 1-3-97 (Register 96, No. 49).

#### **§457. Design and Construction of LNG Vaporizers.**

---

(a) LNG Vaporizers:

(1) Vaporizers having a volumetric capacity in excess of 1 U.S. gallon shall be either:

(A) Constructed, inspected and stamped in accordance with the ASME Code unless the design and construction of the vaporizer are accepted by the Division as equivalent to ASME Code, or;

(B) Fabricated and tested in accordance with ~~ANSI~~ ASME B-31.3 when artificial heat is not used for vaporization and when of welded construction consisting of continuous pipe or tubing and fittings not exceeding 6 inches inside diameter, or;

(C) Made of threaded piping and pipe fittings and built to good engineering practice with a factor of safety of not less than 4, taking into account all imposed loadings.

(2) Vaporizers and any part thereof, including carbureting devices, shall be designed for minimum as well as maximum temperatures and the maximum pressure that can be imposed with a safety factor of at least 4.

(3) Vaporizers having a volumetric capacity in excess of 1 U.S. gallon shall be stamped with the information required by the ASME Code and shall also include:

(A) Head and shell thicknesses.

(B) The words "For LNG."

(C) Heat exchange surface in square feet.

(D) The vaporizer capacity per hour in U.S. gallons.

(E) Minimum safety relief valve capacity in CFM air. (See Section 540(c) .)

(b) Vaporizers made of pipe or tubing shall have a nominal diameter of 2 inches or less and shall have the information required in (C) , (D) and (E) above stamped on the nameplate which shall be permanently attached to the vaporizer. This nameplate shall also show the manufacturer's name, year built and maximum allowable working pressure.

NOTE: Authority cited: Section 142.3, Labor Code. Reference: Section 142.3, Labor Code; and Section 13241, Health and Safety Code.

### **Credits**

### **HISTORY**

1. Amendment filed 12-8-72 as procedural and organizational; effective upon filing (Register 72, No. 50).
2. Amendment filed 11-7-75; effective thirtieth day thereafter (Register 75, No. 45).

3. Amendment filed 1-5-88; operative 2-4-88 (Register 88, No. 4).

4. Amendment of section heading, repealer of subsections (a)-(a)(5), subsection relettering, and amendment of NOTE filed 12-4-96; operative 1-3-97 (Register 96, No. 49).

#### **§458. Design and Construction of NH<sub>3</sub> Tanks.**

---

(a) All NH<sub>3</sub> tanks for new installations shall be constructed, inspected, and stamped in compliance with the ASME Code (unless the design, material, and construction of the tank are accepted by the Division as equivalent to the ASME Code and registered with the National Board of Boiler and Pressure Vessel Inspectors. The stamping on all new NH<sub>3</sub> tanks or on nameplates attached thereto shall include the following, in addition to the stamping required by the ASME Code:

(1) The head and shell thicknesses.

(2) The gross volumetric capacity in U.S. gallons.

(3) Total outside surface area of the container in square feet.

(b) The allowable working pressure of any existing NH<sub>3</sub> tank shall be determined by the provisions of the ASME Code effective when the tank was manufactured and upon its condition determined upon inspection. Containers once installed under ground shall not later be reinstalled above ground unless they successfully withstand hydrostatic pressure retests at the pressure specified for the original hydrostatic test as required by the ASME Code under which constructed and show no evidence of serious corrosion.

(c) Any tank used in refrigeration systems or for the refrigerated storage or transportation of NH<sub>3</sub> shall be designed and constructed for an allowable working pressure which takes into consideration the temperature anticipated in the vessel and other appropriate design data.

(d) Except for tanks used in refrigeration systems, any tank used for the unrefrigerated storage, transportation, or utilization of NH<sub>3</sub> shall be designed and constructed in accordance with the ASME Code for an allowable working pressure of at least 265 psig.

(e) All cold formed heads of ferrous material used on NH<sub>3</sub> tanks shall be heat treated, either before or after welding to the tank, in accordance with paragraph UCS-56 of the ASME Code, regardless of the thickness of the metal when the tanks are to be used for transportation of anhydrous ammonia or for the storage of anhydrous ammonia.

(f) Portable tanks or cylinders of 25 water gallons water capacity or less, that are transported inside service trucks for servicing NH<sub>3</sub> refrigeration Systems, shall be built either to the ASME Code or to the DOT specifications but must have a stamped pressure of at least 420 psig.

(g) Spot-radiography, partial radiography or 100% radiography shall be required for all vessels except DOT cylinders.

(h) Nonrefrigerated containers, and system nameplates, when required, shall be permanently attached to the system so as to be readily accessible for inspection and shall be marked as specified in the following:

(1) With the name and address of the supplier of the system or the trade name of the system and with the date of fabrication.

(2) With a notation "Anhydrous Ammonia".

(3) With marking indicating the maximum level to which the container may be filled with liquid anhydrous ammonia at temperatures between 20°F. and 130°F. except on containers provided with fixed level indicators, such as fixed length dip tubes, or containers that are filled by weight. Markings shall be in increments of not more than 20°F.

(i) Marking refrigerated containers except in refrigeration plants where ammonia is used solely as a refrigerant. Each refrigerated container shall be marked with a nameplate on the outer covering in an accessible place as specified in the following:

(1) The maximum allowable water level to which the container may be filled for test purposes.

(2) With the density of the product in pounds per cubic foot for which the container was designed.

(3) With the maximum level to which the container may be filled with liquid anhydrous ammonia.

(4) With a notation "Anhydrous Ammonia".

(j) All NH<sub>3</sub> tanks for new installations with a design pressure of 15 psig or less shall be designed, constructed, inspected and certified in accordance with API Standard 620, ~~1978 Edition~~, with the additional requirements listed in Section 455(h)(1)-(8) of these Orders, which will supersede where there is any conflict, or they may be built to the ASME Code.

(k) The shell or head thickness of any container shall not be less than three-sixteenth inch.

### **Credits**

NOTE: Authority cited: Section 142.3, Labor Code. Reference: Section 142.3, Labor Code.

### **HISTORY**

1. Amendment filed 12-8-72 as procedural and organizational; effective upon filing (Register 72, No. 50).
2. Amendment filed 3-28-75; effective thirtieth day thereafter (Register 75, No. 13).
3. Amendment of subsection (a) filed 4-1-77; effective thirtieth day thereafter (Register 77, No. 14).

4. Amendment filed 1-5-88; operative 2-4-88 (Register 88, No. 4).
5. Amendment of subsection (e) filed 9-23-88; operative 10-23-88 (Register 88, No. 40).

**§459. ~~Liquefied Natural Gas Tanks. (Renumbered)~~ Design and Construction of Pressure Vessels for other than Compressed Air, NH<sub>3</sub> and Natural Gas.**

---

(a) All new pressure vessels for pressures exceeding 15 psig shall be constructed, inspected, and stamped in compliance with the ASME Code, unless the design, material and construction of the vessel are accepted by the Division as equivalent to the ASME Code. All such vessels shall be registered with the National Board of Boiler and Pressure Vessel Inspectors.

(b) All secondhand pressure vessels defined in (a) above shall have been constructed, inspected, and stamped in compliance with the ASME Code (or DOT specifications, if in DOT service) unless the design, material, and construction of the vessel are accepted by the Division as equivalent to the ASME Code.

(c) The allowable working pressure of all existing pressure vessels defined in Section 460(a) shall be calculated in accordance with the ASME Code; or in the case of non-ASME Code pressure vessels, the working pressure shall be determined by the standards of the ASME Code with a design margin of the specified minimum tensile strength divided by the design pressure of at least 3.5.

(d) All pressure vessels for human occupancy shall be designed, fabricated, inspected, tested, marked and stamped in accordance with the applicable ASME Code and ASME PVHO Standard.

(e) All pressure vessels not otherwise covered herein shall be designed and constructed in accordance with the ASME Code or in accordance with good engineering practice for the pressure and service in which they are to be used.

**Credits**

NOTE: Authority cited: Section 142.3, Labor Code. Reference: Section 142.3, Labor Code.

**HISTORY**

1. Repealer and new section filed 1-17-80; effective thirtieth day thereafter (Register 80, No. 3). For prior history, see Registers 77, No. 14, and 72, No. 50.
2. Renumbering of Section 459 to Section 455(h) filed 1-5-88; operative 2-4-88 (Register 88, No. 4).

**§460. ~~Design and Construction of Pressure Vessels for other than Compressed Air, LPG, NH<sub>3</sub> and Natural Gas.~~ Repairs and Alterations to Pressure Vessels.**

---

(a) All new pressure vessels for pressures exceeding 15 psig used for the transportation, storage, or use of any poisonous, corrosive, or flammable substance, or other products at temperatures above their boiling points at atmospheric pressures, or in which the pressure is generated by means of a compressor, shall be constructed, inspected, and stamped in compliance with the ASME Code, unless the design, material and construction of the vessel are accepted by the Division as equivalent to the ASME Code. Except for "UM" vessels, all such vessels shall be registered with the National Board of Boiler and Pressure Vessel Inspectors.

(b) All secondhand pressure vessels defined in (a) above shall have been constructed, inspected, and stamped in compliance with the ASME Code (or DOT specifications, if in DOT service) unless the design, material, and construction of the vessel are accepted by the Division as equivalent to the ASME Code.

(c) The allowable working pressure of all existing pressure vessels defined in Section 460(a) shall be calculated in accordance with the ASME Code; or in the case of non-ASME Code pressure vessels, the working pressure shall be determined by the standards of the ASME Code with a factor of safety of not less than 4.

(d) All pressure vessels not otherwise covered herein shall be designed and constructed in accordance with the ASME Code or in accordance with good engineering practice for the pressure and service in which they are to be used.

(a) Repair and alteration of unfired pressure vessels shall meet all applicable requirements of this Section, and the NBIC, including inspection, workmanship, documentation, and stamping. Whenever the NBIC allows for the acceptance by the jurisdiction having enforcement authority, acceptance shall be requested by the National Board 'R' stamp holder and received from the Division prior to performing those activities. Pressure vessels used for the storage of anhydrous ammonia shall also comply with Section 512 of these safety orders.

(1) Repairs and alterations of unfired pressure vessels performed in a state or country other than California shall be done by a company with a valid National Board 'R' stamp and inspected by an inspector holding a valid National Board Commission. The repair or alteration shall conform to all the requirements of this section and be stamped in accordance with the NBIC.

(2) Repair Organizations shall have a Quality Control System that has been accepted by the Division.

(b) Repairs:

(1) Repairs shall be performed by one of the following repair organizations:

(A) An organization in possession of a valid National Board Certificate of Authorization issued by the National Board of Boiler and Pressure Vessel Inspectors to use the National Board "R" symbol stamp provided that the repair is within the scope of such authorization;

(B) An organization in possession of a valid ASME Certificate of Authorization for unfired pressure vessels they originally manufactured.

(2) The employer making the repair in accordance with the NBIC shall provide for inspection, documentation and certification of the work and shall ensure prior authorization for the repair by a Qualified Inspector.

(3) Inspection and certification of repairs shall be made by a Qualified Inspector.

(4) Fillet weld patches shall not be permitted unless acceptable to the Division. Acceptance by the Division will be based on the materials, design and construction providing safety equivalent to the original code of construction.

(5) NBIC routine repairs are not permitted.

(c) Alterations:

(1) Alterations to unfired pressure vessels shall be performed in compliance with the NBIC, unless the material design and construction are accepted by the Division as equivalent to the ASME Code.

(2) No alteration to an unfired pressure vessel shall be made until authorized by a Qualified Inspector as defined in the Unfired Pressure Vessel Safety Orders.

(3) Alterations shall be performed by one of the following repair organizations:

(A) An organization in possession of a valid Certificate of Authorization issued by the National Board of Boiler and Pressure Vessel Inspectors to use the National Board "R" symbol stamp provided that the alteration is within the scope of such authorization.

(B) An organization in possession of a valid ASME Certificate of Authorization for unfired pressure vessels they originally manufactured.

(4) The employer making the alteration shall provide for inspection, documentation, and certification of the work and shall ensure prior authorization of the alteration by a Qualified Inspector holding a valid Certificate of Competency issued by the Division.

(5) Inspection and certification of alterations shall be made by a Qualified Inspector provided the alteration work was not performed by the Qualified Inspector's employer.

(6) A pressure test shall be applied after an alteration in accordance with the applicable ASME Code section. An alternative test or examination may be used subject to prior acceptance by the Division.

(d) The employer responsible for an unfired pressure vessel that requires a Permit to Operate shall provide the Division with the following documentation:

(1) A completed National Board Form R-1 Report of Welded Repair or Form R-2 Report of Alteration or equivalent.

(2) A facsimile or rubbing of the Repair/Alteration stamping applied to the vessel.

(e) The employer responsible for repairs and alterations done to ASME Code unfired pressure vessels subject to these Orders, including those requiring a Permit to Operate, shall have a National Board R-1 or R-2 form (or equivalent) completed and sent to the National Board for Certification and Registration.

(f) Repair/Alteration stampings shall be in accordance with the NBIC. For companies qualified to perform repairs and alterations using their ASME Certificate Holder and Original Manufacturer, a similar stamping without the National Board symbol stamp shall be applied.

### **Credits**

NOTE: Authority cited: Section 142.3, Labor Code. Reference: Section 142.3, Labor Code.

### **HISTORY**

1. Repealer and new section filed 1-17-80; effective thirtieth day thereafter (Register 80, No. 3). For prior history, see Register 78, No. 13.
2. Editorial correction of History No. 1 (Register 81, No. 8).
3. Amendment filed 1-5-88; operative 2-4-88 (Register 88, No. 4).

### **Article 3. Air tanks**

---

#### **§461. Permits to Operate.**

---

(a) Except during the time that a request for a permit remains unacted upon or as permitted in Section 461(f), no air tank shall be operated unless a permit to operate has been issued.

(b) Except during the time that a request for a permit remains unacted upon, every person owning or having the custody, management, or operation of an air tank which requires a permit to operate who operates it without a permit is guilty of a misdemeanor. Operating an air tank without a permit constitutes a separate offense for each day that it is so operated.

(c) The permit shall be posted under glass in a conspicuous place on or near the air tank or in a weatherproof container secured to the unit, and shall be available at all times to any qualified inspector.

(d) Except as provided in Subsection 461(h), the permit for portable air tanks shall expire not more than three years from the date of inspection and for all other air tanks not more than 5 years from the date



of inspection or upon the alteration of, or damage to, the air tank or installation, or upon change of ownership and location, whichever occurs first.

NOTE: The permit shall not expire upon change of ownership and location for portable tanks.

(e) A temporary permit to operate may be issued for not more than 30 days to allow a reasonable time for required changes to be made.

(f) Air tanks having a volume of 1 1/2 cubic feet or less which have safety valves set to open at not more than 150 psi do not require permits to operate, but shall comply with all other provisions of these Orders, including construction. Air tanks used for self-contained breathing apparatus and having a volumetric capacity of 1 cubic foot or less and constructed, inspected, and maintained in accordance with DOT regulations do not require permits to operate.

(g) No person, firm, or company shall rent or offer for rent for use in a place of employment any air tank requiring a permit to operate unless the required permit has been issued by or in behalf of the Division.

(h) Air tanks subject to a maximum allowable working pressure not exceeding 150 psi., as shown by the required code marking, and having a volume of 25 cubic feet or less shall be inspected when placed into service. An indefinite permit shall be issued provided that the tank has been constructed, inspected and stamped in compliance with the ASME Code, or the design, material, and construction of the tank is accepted by the Division as equivalent to the ASME Code and the tank is in compliance with the applicable provisions of these orders. A new inspection and permit for operation shall be required whenever there is a change of ownership and permanent location of the tank or there is an alteration or change in the tank which affects the tank's safety.

### **Credits**

NOTE: Authority cited: Section 142.3, Labor Code. Reference: Sections 142.3, 7681 and 7683, Labor Code.

### **HISTORY**

1. Amendment filed 12-8-72 as procedural and organizational; effective upon filing (Register 72, No. 50).
2. Amendment of subsection (d) and new subsection (h) filed 12-18-81; effective thirtieth day thereafter (Register 81, No. 51).

### **§462. Field Inspections and Reports.**

---

(a) All air tanks requiring a permit to operate shall be inspected internally and externally at least once every 3 years for portable tanks and once every 5 years for all other tanks by a qualified inspector.

This subsection shall not be applicable for air tanks which fulfill the requirements for an indefinite permit as provided in Section 461(h).

EXCEPTION: The internal inspection of tanks less than 2 years old may be waived at the discretion of the inspector, provided all other requirements of Section 462(c) are met.

(1) Ultrasonic thickness determination shall be permitted in lieu of, or in conjunction with, internal inspection for air tanks of 36" diameter or less. Thickness determinations shall be made in at least eight areas: two on each head and two on both the top (upper) and bottom (lower) portions of the shell.

For air tanks of greater than 36" diameter, an internal inspection shall be performed. In lieu of this internal inspection, an external inspection may be performed to determine the tank thickness and the permit shall be limited to 36 months. For a horizontal tank; readings shall be taken on one foot centers along the bottom of the tank (180°), two readings equally spaced for each shell course shall be taken at 0°, 90°, 135°, 225°, and 270° with 0° being top dead center of the course, and four readings on each head. For a vertical tank: eight readings shall be taken on the bottom head with at least one reading as close as possible to the bottom center, four readings at 0°, 90°, 180°, and 270° on each course within two inches of the lower circumferential weld and four readings at 0°, 90°, 180°, and 270° at the mid-point of each course, and four readings on the top head. The location of each reading shall be permanently marked so any future readings may be taken from the same location.

Thickness determinations indicating significant reduction in the material thickness over a general area (~~use National Board Inspection Code 1992 NBIC Par. U-107 may be used as a guide for guidance~~) shall be shown on the inspection report as well as the calculations for the reduction in the allowable working pressure.

The qualified inspector's employer shall ~~be responsible for~~ verify the inspector's or ultrasonic examiner's competency in the use of the ultrasonic thickness gage, and the examiner's signed report shall be attached to the qualified inspector's inspection report.

(2) Air tanks shall be installed so that all drains, handholes, inspection plugs and manholes therein are easily accessible. Air tanks shall be supported with sufficient clearance to permit a complete external inspection and to avoid corrosion of external surfaces. Under no circumstances shall an air tank be buried underground or located in an inaccessible place.

(b) The owner or user of any air tank shall prepare it for inspection and make provisions to permit the required inspections to be made safely when requested to do so by the Division or a qualified inspector.

(1) Preparation for an internal inspection shall include the removal of such inspection plugs or plates as are deemed necessary by the qualified inspector.

(2) The qualified inspector shall decide whether a hydrostatic pressure test is necessary and if it is ordered, the owner or user shall make the necessary preparations for such tests by blanking off connections and filling the tanks with water and pressurizing the tank.

(3) If the owner or user finds the date set for inspection not convenient, the owner or user shall immediately ask the Division for a postponement and give good cause, in which case the inspection shall

be permitted to be postponed for a period of not more than 30 days from the date first set for inspection.

(c) All air tanks subject to inspection under these Orders and regularly inspected by qualified inspectors not employed by the Division shall be exempt from periodic inspection by the Division if the tanks and systems conform to these Safety Orders and:

(1) Reports of all air tank inspections are submitted to the Division within 21 days of inspection;

(2) Reports indicate whether internal inspection or external inspection under pressure, or both, have been made.

(3) Reports give the reasons for any refusal to issue a permit and for any change in the allowable working pressure;

(4) Reports specify in detail the condition of the air tank and any changes or repairs ordered. If changes or repairs are ordered, a written report shall be furnished to the owner or user of the tank by the inspecting agency.

(d) Permits shall be issued only if tanks and systems comply in all respects with these orders and all inspection fees are paid.

(e) Qualified inspectors employed by insurance companies shall immediately notify the Division of the name of the owner or user, as shown on the permit to operate, the location and state serial number of every air tank on which insurance has been refused, canceled or discontinued, and shall give the reasons why.

(f) Qualified inspectors employed by other than insurance companies shall immediately notify the Division of the name of the owner or user and the location and state serial number of every tank inspected by them which is removed from active service or which is considered unsafe for further service as an air tank, and shall give the reasons why.

NOTE: Nothing in these order shall prevent a qualified safety engineer employed by the Division from inspecting any tank. However, no inspection fee shall be charged by the Division where the required inspection has been made and the provisions of subsection (c) above have been met.

(g) Qualified inspectors making the first field inspection of air tanks required by these Orders to have a permit to operate shall stamp on the tank a State serial number (unless a State serial number has previously been stamped thereon) which shall become a permanent means of identification. This assigned number shall be made either by steel die figures not less than 5/16 inch in height, or outlined by means of center punch dots with figures not less than 3/4 inch in height, and shall be stamped adjacent to the manufacturer's ASME Code stamping or above an inspection opening if the ASME Code stamping is not accessible.

(h) No state serial number or ASME Code stamping shall be permanently covered by insulating or other material unless such number and stamping is transferred to a fixed plate readily visible outside of all insulating material.

(i) Whenever the condition of an air tank is such as to make it unfit for air pressure service, a qualified inspector ~~safety engineer employed by the Division~~ may affix a rejection mark (Xo) consisting of an "X" at least 1 inch in height with a circle at least 1/2 inch in diameter located between the upper arms of the "X". The rejection mark shall be outlined in center punch marks and located immediately above or adjacent to the state serial number.

(j) All air tanks shall have inspection openings in compliance with the ASME Code. When inspection openings are not provided, the owner or user shall provide such openings, one (1) in each head or in the shell near each head and approximately opposite the longitudinal seam, as follows:

(1) Tanks 12 inches or less in inside diameter shall have at least two threaded openings not less than 3/4 inch pipe size.

(2) Tanks less than 18 inches and more than 12 inches in inside diameter shall have at least two handholes or two plugged, threaded openings not less than 1 1/2 inch pipe size.

(3) Tanks 18 inches to and including 36 inches in inside diameter shall have a manhole or at least two handholes or two plugged, threaded inspection openings not less than 2-inch pipe size.

(4) Tanks exceeding 36 inches in inside diameter shall have a manhole, except those whose shape or use makes a manhole impractical; in which case two handholes 4 inches by 6 inches or two openings of equivalent area may be substituted for the manhole opening.

(5)(A) An elliptical manhole shall be not less than 11 inches by 15 inches or 10 inches by 16 inches in size. The inside diameter of a circular manhole shall be not less than 15 inches.

(B) A handhole shall be at least 2 inches by 3 inches in size. It may be larger, depending upon the size of the tank and the location of the opening.

(C) All access and inspection openings shall be designed in accordance with the rules of the ASME Code for openings.

(k) Air tanks used in systems which have had moisture removed to the degree that the air has an atmospheric dew point of -50° F or less, shall not be required to have inspection openings.

(l) Air tanks shall meet and be installed in accordance with the following requirements:

(1) Air tank supports and appurtenances shall be in accordance with Paragraph UG-22 and recommended design practices of Appendix G of Section VIII, Division 1 of the ASME Code with sufficient clearance provided under the tank to allow for operation of the drain valve.

(2)(A) Air compressor units which have a reciprocating compressor and a driving unit over two horsepower mounted on the tank shall be in accordance with the requirements of paragraphs (B) and (C) as follows:

(B) The tank manufacturer's data report shall show the tank and machinery supports provided by the tank manufacturer. When reinforcing pads are used as a means of stress distribution at the legs and/or

base plate attachment they shall be designed to minimize regions of high stress concentration and be sealed in such a manner as to inhibit corrosion.

(C) Based on written certification from the vessel manufacturer stating compatibility of the vessel and compressor-driving system, the assembler shall permanently affix a label or apply stamping with letters and figures not less than 5/32 inch in height to the side of the vessel machinery platform showing 462(l)(2) compliance. In those cases where the tank manufacturer is the assembler, this data shall be permitted to be stamped on the ASME Code nameplate, separated from the ASME Code stamping. Upon request of the Qualified Inspector or the Division, design calculations incorporating system dynamics or experimentally obtained test data shall be furnished by the tank manufacturer to verify compliance with this Order.

(D) New air tanks not complying with this subsection shall not have a reciprocating compressor and driving unit mounted on the tank unless the supports are modified to the satisfaction of the Qualified Inspector, and the Division.

(3) All visible undercuts at butt, groove, or fillet welds must be repaired prior to issuance of the permit to operate.

(4) The employer shall notify the Division and the inspection agency before further use in the event of cracking or leaking of the air tank.

(5) If an air tank has cracked because of the compressor mounting or supports, the compressor and driving unit shall be reinstalled separately from the air tank in accordance with the requirements of the applicable Safety Orders, unless the supports are modified to the satisfaction of the Qualified Inspector and the Division. Whenever possible, the reinstallation of the compressor and driving unit shall be in accordance with the recommendations of the original assembler. The reinstallation must be acceptable to the Qualified Inspector.

(m)(1) Air piping shall be in accordance with ~~ANSI~~ ASME B31.1 or B31.3.

(2) All piping from the tank to the first shut-off valve shall be Schedule 80 metallic pipe.

(3) Plastic piping systems may be used for compressed air conveyance above and below ground, when meeting all of the following requirements:

EXCEPTION: Pipe or tubing under 3/8-inch diameter need not meet these requirements.

(A) Only ductile plastic materials shall be used.

(B) Only plastic pipe, valves and fittings recommended for use by the manufacturer to convey compressed air shall be used.

(C) Plastic pipe, valves and fittings shall not be used for compressed air systems over 150 psi or temperatures over 140°F.

(D) Plastic piping systems shall be designed, installed, maintained, and operated in full accordance with the manufacturer's specifications and instructions.

(E) All plastic pipe shall be permanently marked continuously, but not to exceed 5-foot intervals, with the following information:

1. Size;
2. Manufacturer's name;
3. Pressure rating at 73°F and 140°F;
4. Material name, specification, ASTM cell classification, batch number, and the date of manufacture;
5. The words "For Compressed Air"; and
6. Either Schedule, "Sch Number:", or Standard Dimension Ratio, "SDR Number".

(F) All plastic valves and fittings shall be permanently marked with the following:

1. Size;
2. Manufacturer's name or logo;
3. Pressure rating at 73°F; and
4. Material name.

(G) Plastic valves and fitting shall be of the same manufacturer and materials as the pipe.

(H) Only joining compounds meeting or exceeding manufacturer's specifications shall be used when assembling the plastic pipe.

(I) The employer shall use pipe that meets or exceeds the test requirements listed in Appendix C, and upon request, supply the Division written laboratory certification from the manufacturer that the pipe meets or exceeds all test requirements listed in Appendix C of these orders.

(J) The pipe system components, pipe, valves, fittings, and joining compounds shall be designed for the full working pressure of the system for its design life.

(4) Plastic pipe and fittings that do not meet the requirements of subsection (m)(3) may be used in compressed air service, provided that all of the following conditions are satisfied:

(A) Pressure shall be limited to 150 psi, temperature to 120°F, size up to 2-inch diameter pipe size, and wall thickness to Schedule 40 or heavier;

(B) The piping system shall be protected from mechanical damage along its entire length by either location or actual guarding. The guarding shall be of sufficient strength to withstand any anticipated impact. It shall also be capable of containing exploding fragments; and

(C) The piping system shall be supported and secured by U bolts, conduit supports, rigid hangers or similar methods at intervals not to exceed five (5) feet.

(n) Any air tank having dished heads or conical heads the skirt (flange) and/or the knuckle radius of which does not meet the minimum ASME Code requirements shall have such heads stayed as flat surfaces in accordance with the ASME Code rules for braced and stayed flat plates. Any head dished to a radius greater than the diameter of the tank to which it is attached shall be stayed as a flat surface in accordance with the ASME Code rules for braced and stayed flat plates. No allowance shall be taken in such calculations for the curved portion of the head.

(o) All air tanks, including existing installations, having unstayed dished heads without a transition knuckle for attachment to the shell shall be permanently removed from service with the rejection mark affixed by the qualified inspector, as required in Section 462(i).

(p) The bottom dished head of an air tank operated in the vertical position shall not be dished inward but must be concave to pressure.

### **Credits**

NOTE: Authority cited: Section 142.3, Labor Code. Reference: Sections 142.3, 7650 and 7681, Labor Code.

### **HISTORY**

1. Repealer and new subsection (m) filed 2-8-78; effective thirtieth day thereafter (Register 78, No. 6). For prior history, see Register 77, No. 26.

2. Amendment of subsection (m) filed 3-10-78 as an emergency; effective upon filing (Register 78, No. 6).

3. Amendment of subsection (m) refiled 6-2-78 as an emergency; effective upon filing. Certificate of Compliance included (Register 78, No. 22).

4. Amendment of subsection (m) filed 12-4-78 as an emergency; effective upon filing (Register 78, No. 49).

5. Certificate of Compliance filed 3-23-79 (Register 79, No. 12).

6. Amendment of subsections (a) and (m) filed 6-15-79; effective thirtieth day thereafter (Register 79, No. 24).

7. Amendment of subsection (a) filed 12-18-81; effective thirtieth day thereafter (Register 81, No. 51).

8. Amendment filed 1-5-88; operative 2-4-88 (Register 88, No. 4).
9. Amendment of subsections (k) and (m) filed 4-8-92; operative 5-8-92 (Register 92, No. 18).
10. Editorial correction relocating EXCEPTION in the subsection (m)(3) (Register 2021, No. 40).

**§463. Certification of Inspectors.**

---

Inspectors shall be certified in accordance with Section 779 of the Boiler and Fired Pressure Vessel Safety Orders.

**Credits**

HISTORY

1. Amendment filed 12-8-72 as procedural and organizational; effective upon filing (Register 72, No. 50).

**§464. Air Tank Inspection Fees. (Repealed)**

---

**Credits**

NOTE: Authority cited: Section 142.3, Labor Code. Reference: Section 142.3, Labor Code.

HISTORY

1. New section filed 3-28-78; effective thirtieth day thereafter (Register 78, No. 13). For history of former section, see Register 77, No. 49.
2. Repealer filed 1-5-88; operative 2-4-88 (Register 88, No. 4).

**§465. Safety Devices and Systems.**

---

(a) Each air tank shall be protected by 1 or more safety valves and other indicating and controlling devices that will insure safe operation of the tank. If the tank has a volumetric capacity in excess of 2,000 gallons, it shall be fitted with at least 2 safety valves, the smallest of which shall have a relieving capacity of at least 50 percent of the relieving capacity of the largest valve.



(b) Safety relief valves shall:

(1) Be constructed and installed in accordance with the ASME Boiler and Pressure Vessel Code, Section VIII.

(2) Be located and installed so that they cannot be readily rendered inoperative.

(A) No valve of any description shall be placed between the required safety valve or rupture disc and the air tank.

(B) The opening or connection between the tank and safety valve or valves shall have a cross-sectional area at least equal to the combined areas of all attached safety valve inlets.

(3) Be of the direct spring-loaded type. The springs shall not be adjusted to carry more than: 10 percent greater pressure than the set pressure stamped on the valve up to and including 250 psig; or 5 percent greater pressure than the set pressure stamped on the valve above 250 psig.

(A) For pressures of 2000 psig or less safety valves shall be equipped with a substantial lifting device so that the disc can be easily lifted from its seat not less than 1/8 the diameter of the seat when the pressure in the tank is 75 percent of that at which the safety valve is set to open.

(B) For pressures exceeding 2000 psig: the lifting device may be omitted providing the valve is removed for testing at least once each year and a record kept of this test and made available to the qualified inspector; acceptable rupture discs may be used in lieu of safety valves provided they are in compliance with Section 465(b)(2), (4) and (5).

(4) Be set to open at not more than the allowable working pressure of the tank.

(5) Have a relieving capacity sufficient to prevent a rise of pressure in the tank of more than 10 percent above the allowable working pressure when all connected compressors are operating with all unloading devices rendered inoperative.

(6) When exposed to a temperature of 32 degrees Fahrenheit or less, have a suitable drain at the lowest point where water can collect.

(7) Not have seats or discs of cast iron.

(8) Be tested frequently and at regular intervals to determine whether they are in good operating condition.

(c) Discharge pipes from safety valves and rupture discs installed on air tanks shall:

(1) Have a cross-sectional area at least equal to the combined outlet areas of all valves discharging into them.

(2) Be designed and installed so that there will be no interference with the proper operation or discharge capacity of the safety valve or rupture disc.

(3) Have no valve of any description.

(4) Be fitted with open drains which will prevent the accumulation of liquid above the safety valve or rupture disc.

(5) Be installed and supported in a manner that will prevent undue stresses on the safety valve or rupture disc.

(6) Be led to a safe place of discharge.

(d) Each air tank shall be equipped with a suitable pressure indicating gage with the dial graduated to approximately double the operating pressure, but in no case less than 1.2 times the pressure at which the safety-relieving device is set to function.

(e) Each air tank shall be equipped with a manually operated, valved drain located at the lowest point where water can collect. The valve for this drain shall be suitably located for convenient operation. Automatic drains shall not be considered as complying with this order unless also equipped with a manually operated by-pass.

NOTE: It is recommended that each air tank be completely drained of accumulated moisture at least once during each day of operation.

### **Credits**

NOTE: Authority cited: Section 142.3, Labor Code. Reference: Section 142.3, Labor Code.

### **HISTORY**

1. Amendment filed 12-8-72 as procedural and organizational; effective upon filing (Register 72, No. 50).
2. Amendment of subsection (a) filed 10-25-74; effective thirtieth day thereafter (Register 74, No. 43).
3. Amendment filed 1-5-88; operative 2-4-88 (Register 88, No. 4).

### **~~§466. Repairs and Alterations.~~**

---

~~(a) No alteration or repair affecting the safety of any air tank covered by these Orders shall be made without the authorization of a qualified inspector.~~

~~(b) Any air tank which has suffered mechanical damage causing dents or other deformations exceeding a depth of 1 1/2 times the thickness of the deformed head or shell or two percent of the tank diameter, whichever is greater, shall be properly reformed to its original shape or otherwise repaired as provided in these Orders. Deformations less than these amounts located in areas of high stress concentration~~

and/or having abrupt changes in configuration may be required to be reformed to their original shape at the discretion of the qualified inspector.

(c) Any areas that are deteriorated by internal or external corrosion or by mechanical abrasion that affects the safety of the tank shall be properly re-aired or the allowable working pressure shall be reduced proportionately. The building up by welding of such area is prohibited, except isolated pits shall be permitted to be properly prepared and welded at the discretion of the qualified inspector.

(d) No welded repair shall be permitted on a tank of brazed construction. If inspection openings are required in such tanks, they may be machine-cut and closed with handhole plates.

(e) Any welding necessary when making major repairs or alterations to tanks shall be done by a welder qualified in accordance with Section IX of the ASME Code in the position or positions used in making the repair or alteration.

(1) When minor welding repairs or alterations, such as closing openings not exceeding 2 inch pipe size, installing reinforcing rings around handhole openings, installing staybolts or through stays, etc., are made by a welder who is not ASME qualified, these repairs or alterations shall be authorized and approved by a qualified inspector.

(f) The qualified inspector who authorizes any welded repair or alteration shall report it to the Division within 21 days, giving full details, including the State serial number of the tank, the name and address of the owner or user, the location of the tank, and the name and address of the welder and the welder's employer.

(1) The qualified inspector shall stamp his/her certificate of competency number adjacent to all welded repairs authorized.

(g) If the longitudinal seam of any non-code air tank of welded construction is found to have incomplete penetration of the welded joint, the tank shall not be repaired. Such tanks shall be permanently removed from service, with the rejection mark affixed by the qualified inspector, as required in Section 462(i).

### **Credits**

NOTE: Authority cited: Section 142.3, Labor Code. Reference: Section 142.3, Labor Code.

### **HISTORY**

1. Amendment filed 12-8-72 as procedural and organizational; effective upon filing (Register 72, No. 50).
2. Amendment filed 1-5-88; operative 2-4-88 (Register 88, No. 4).

## **Article 4. Pressure Vessels Other than Air Tanks, LPG, NH<sub>3</sub> and CNG or LNG Tanks**

---

## **§467. Controls.**

---

(a) Any pressure vessel not specifically covered or exempted elsewhere in these Orders shall be protected by one or more safety valves or rupture discs set to open at not more than the allowable working pressure of the vessel and by such other controlling and indicating devices as are necessary to insure safe operation of the pressure vessel.

(b) The owner or user of any pressure vessel not specifically covered or exempted elsewhere in these Orders shall provide such inspection and maintenance as is necessary to insure safe operation of the pressure vessel.

### **Credits**

NOTE: Authority cited: Section 142.3, Labor Code. Reference: Section 142.3, Labor Code.

### **HISTORY**

1. Amendment filed 12-8-72 as procedural and organizational; effective upon filing (Register 72, No. 50).
2. Amendment filed 1-5-88; operative 2-4-88 (Register 88, No. 4).

## ***Article 5. LP-Gas Systems***

---

The provisions of Article 5 need not apply to liquefied petroleum gas installations up to the point of delivery to a transportation tank in plants manufacturing this product, nor beyond the storage tanks in plants using this product for processing only and not for fuel; provided, however, that tanks used in such plants shall be designed and constructed in accordance with provisions of Article 2, and shall be maintained and operated in accordance with the provisions of Article 4 of these Orders.

## **§470. Permit to Operate.**

---

(a) Except during the time a request for a permit remains unacted upon, no employer or employee shall use or cause to be used any pressure vessel for the storage or transportation of LP-Gas without first securing from the Division a permit to operate such container. The Division shall be notified within seven days of all temporary installations.

EXCEPTION: No permit to operate shall be required for pressure vessels of 125 gallons capacity or less or for cylinders used, inspected, and maintained in accordance with DOT regulations.

(b) Permits to operate dispensing units, ~~trap tanks~~, movable fuel storage tenders including farm carts and weed burners, and ~~skid tanks~~ portable storage containers shall expire in not more than 3 years while the permit to operate transportation tanks, mobile fuel tanks, and stationary storage tanks shall expire in not more than 5 years.

It is intended that failure to maintain the installation in compliance with these Safety Orders will be justification to void the permit and require reinspection.

(c) The permit to operate any tank shall expire when any of the following occurs:

(1) The tank changes both ownership and location.

(2) ~~Alterations~~ Changes are made which affect the safety of the installation.

(3) The tank has suffered mechanical or fire damage.

The permit to operate shall not expire due to the exchange or interchange of approved appurtenances intended for the same purposes.

(d) The permit to operate, or an acceptable copy, shall be kept readily available on the premises upon which the tank is located and shall be available at all times to any qualified inspector. In the case of a transportation tanks, or portable tank movable fuel storage tenders, farm carts, weed burners or mobile fuel tanks, the permit may be carried in the cab of the towing vehicle or in a suitable weatherproof container secured to the unit.

(e) No person shall charge LP-Gas into any tank requiring a permit to operate unless the permit to operate has been issued and posted, except where a request for a permit remains unacted upon. Containers shall be filled or used only upon authorization of the owner.

(f) No permit to operate shall be issued for any tank until all provisions of these Orders have been complied with and the required fee has been paid.

(g) Any tank that has been used for the storage or transportation of products other than LP-Gas shall be inspected internally by a qualified inspector at the time of the periodic inspection required by Section 470 (i)-.

(h) At the time of the first field inspection of each tank requiring a permit to operate, the qualified inspector shall stamp on the tank a state serial number in accordance with Section 462 (h)-.

(i) Except as permitted in Section 470 (a) each LP-Gas tank shall be inspected in accordance with the intervals shown in Section 470 (b)-.

(j) Inspectors shall be certified in accordance with Section ~~463~~ 779 or the Boiler and Fired Pressure Vessel Safety Orders.

## Credits

NOTE: Authority cited: Section 142.3, Labor Code. Reference: Section 142.3, Labor Code; and Section 13241, Health and Safety Code.

#### HISTORY

1. Amendment of subsections (b) and (j) filed 12-8-72 as procedural and organizational; effective upon filing (Register 72, No. 50).
2. Amendment of subsection (e) filed 11-7-75; effective thirtieth day thereafter (Register 75, No. 45).
3. Amendment of subsections (a), (b) and (c)(3) and new NOTE filed 12-4-96; operative 1-3-97 (Register 96, No. 49).

#### **§471. Control of Products in Tanks and Cylinders.**

---

(a) No LP-Gas shall be transported or delivered into any vessel covered by these Orders until first odorized using a warning agent of such character that the gases are detectable, by a distinct odor, down to a concentration in air of not over one-fifth the lower limit of flammability.

EXCEPTION: When the LP-Gas is to be used exclusively in a process where the presence of an odorant would make the LP-Gas unfit for use in the process and for deliveries between refineries or between producing wells and refineries, a waiver may be obtained from the Division upon written request.

#### **Credits**

NOTE: Authority cited: Section 142.3, Labor Code. Reference: Section 142.3, Labor Code; and Section 13241, Health and Safety Code.

#### HISTORY

1. Amendment filed 12-8-72 as procedural and organizational; effective upon filing (Register 72, No. 50).
2. Amendment of section, including repealer of figure 1, and new NOTE filed 12-4-96; operative 1-3-97 (Register 96, No. 49).
3. Repealer and new section filed 1-30-2002; operative 3-1-2002 (Register 2002, No. 5).

#### **§472. Charging LP-Gas Containers.**

---

(a) Air pressure shall not be used to displace LP-Gas during the transfer operation.

(b) All filling connections shall be kept effectively plugged or capped when not in use. These caps or plugs shall be so designed that they will vent to the atmosphere while at least 3 full threads are engaged.

(c) An accessible 24-hour communication service shall be required for self-service dispenser systems.

### **Credits**

NOTE: Authority cited: Section 142.3, Labor Code. Reference: Section 142.3, Labor Code; and Section 13241, Health and Safety Code.

### **HISTORY**

1. Amendment of subsection (e)(1)(D) filed 3-15-77; effective thirtieth day thereafter. (Register 77, No. 12). For prior history see Register 76, No. 51.

2. Amendment of subsection (e)(3) filed 5-6-77; effective thirtieth day thereafter (Register 77, No. 19).

3. Amendment of section heading and section, including repealer of table 472, and new NOTE filed 12-4-96; operative 1-3-97 (Register 96, No. 49).

### **§473. Gauging Devices.**

---

(a) A permanent dip pipe or a fixed level gauge shall be installed in all containers filled by volume and shall be of such length or position that it will indicate when the tank ~~is 86 1/2 percent full~~ has reached the maximum permitted LP-Gas volume as indicated in the appropriate section of NFPA 58.

(1) This fixed dip tube or fixed level gauge shall be permanently installed in the tank. Additional dip pipes or fixed level gauges may be used providing they are permanently marked to show the outage they indicate.

(b) Each tank 125-gallon capacity or more, filled by volume, shall be equipped with a liquid level gauging device, such as a rotary gauge, magnetic gage, or series of fixed pipes, in addition to the fixed dip pipe required in Section 473(a)-.

(c) Each tank having an allowable working pressure of less than 250 psi shall have a thermometer well. This Order does not apply to tanks built before January 1, 1946, or to code tanks constructed in accordance with Para-graphs U-68, U-69, and UW-52 (b) for a working pressure of 200 psi or more. The thermometer well shall be plugged or capped when not in use to prevent the entrance of moisture and the resulting hazard of corrosion.

### **Credits**

NOTE: Authority cited: Section 142.3, Labor Code. Reference: Section 142.3, Labor Code; and Section 13241, Health and Safety Code.

## HISTORY

1. Amendment filed 12-8-72 as procedural and organizational; effective upon filing (Register 72, No. 50).
2. Amendment filed 11-7-75, effective thirtieth day thereafter (Register 75, No. 45).
3. Amendment of section heading and section, including repealer of table 473 and figure 2, and new NOTE filed 12-4-96; operative 1-3-97 (Register 96, No. 49).

### **§474. Approval of Devices.**

---

(a) All devices which are used in LP-Gas installations shall be of an approved type and construction suitable for the use intended. See "Approved."

(b) LP-Gas shall not be used to operate any device or equipment designed to be operated with compressed air unless also designed and approved for LP-Gas, nor shall LP-Gas vapor be released into the air, except as provided for by these Orders.

(c) Container valves, connectors, regulators, manifolds, piping, and tubing shall not be used as structural supports for heaters.

(d) All electrical wiring and electrical equipment shall be in accordance with the Electrical Safety Orders administered by the Division and NFPA 58 ~~Section 3-7.2~~.

### **Credits**

NOTE: Authority cited: Section 142.3, Labor Code. Reference: Section 142.3, Labor Code; and Section 13241, Health and Safety Code.

## HISTORY

1. Amendment filed 12-8-72 as procedural and organizational; effective upon filing (Register 72, No. 50).
2. Amendment of subsections (a) and (d) filed 10-17-75; effective thirtieth day thereafter (Register 75, No. 42).
3. Repealer and new subsection (e) filed 11-7-75; effective thirtieth day thereafter (Register 75, No. 45).
4. Amendment filed 1-6-83; effective thirtieth day thereafter (Register 83, No. 2).
5. Amendment of subsection (e), Table 474, Part D filed 7-8-85; effective thirtieth day thereafter (Register 85, No. 28).
6. Editorial reprinting of 7-8-85 order and correction of Register 85, No. 28 revision record sheet



changing Chapter 3.5 to Chapter 4, Subchapter 1 (Register 85, No. 38).

7. Editorial correction of HISTORY 6 (Register 95, No. 21).

8. Amendment of section, including repealer of table 474 and figure 474, and amendment of NOTE filed 12-4-96; operative 1-3-97 (Register 96, No. 49).

#### **§475. Location of Storage Containers and Regulating Equipment.**

---

(a) A single container of 575 gallons or less water capacity can be located 10 feet from an important building providing such container is at least 25 feet from any other container of more than 125 gallons water capacity. For important buildings constructed of concrete or masonry materials with no overhanging roof:

(1) A single container up to 500 gallons capacity may be located not less than 3 feet from an important building provided there is no opening in the building within 10 feet.

(2) A single container 501 to 1200 gallons capacity may be located not less than 3 feet from an important building provided there is no opening in the building within 25 feet.

(b) No stationary storage container shall be located less than 10 feet from the nearest street line or sidewalk, or less than ~~50~~ 25 feet from the center line of any railroad main track.

(c) Installation of stationary LP-Gas containers on the rooftop shall be prohibited.

#### **Credits**

NOTE: Authority cited: Section 142.3, Labor Code. Reference: Section 142.3, Labor Code; and Section 13241, Health and Safety Code.

#### **HISTORY**

1. Amendment filed 4-1-77; effective thirtieth day thereafter (Register 77, No. 14). For prior history, see Register 76, No. 32.

2. New subsection (g) filed 9-11-81; effective thirtieth day thereafter (Register 81, No. 37).

3. Amendment filed 4-13-82; effective thirtieth day thereafter (Register 82, No. 16).

4. Amendment of subsection (a) filed 9-3-82; effective thirtieth day thereafter (Register 82, No. 36).

5. Amendment of section and NOTE filed 12-4-96; operative 1-3-97 (Register 96, No. 49).

6. New subsection (c) filed 1-30-2002; operative 3-1-2002 (Register 2002, No. 5)

## §476. Location and Installation of Underground Tanks. (Repealed)

---

### HISTORY

1. Amendment filed 12-8-72 as procedural and organizational; effective upon filing (Register 72, No. 50).
2. Repealer and new subsection (a) filed 11-7-75; effective thirtieth day thereafter (Register 75, No. 45).
3. Repealer filed 12-4-96; operative 1-3-97 (Register 96, No. 49).

## §477. Installation of Containers.

---

### (a) Aboveground Containers.

(1) Metallic structural supports, when used, shall be encased in concrete or other material having a fire-resistant rating of at least 2 hours when the distance between the lower surface of the tank and the top of the concrete or masonry foundation exceeds 18 inches.

(2) Aboveground storage containers shall be installed with Vehicular Barrier Protection (VBP) complying with NFPA 58 ~~protected from impact from vehicles by means of crashposts, curbs, fences, railings or similar barriers~~. Where crashposts (steel bollards) are used, they shall be no less than 5 6 feet long with 2 3 feet below ground and encased in a concrete footing not less than 15 inches in diameter. Posts shall be no less than 4 inches in diameter and be filled with concrete if the wall thickness is less than that of standard pipe. Posts shall be 4 feet apart on centers (maximum) and at least 3 feet from the storage container. Other materials may be used and shall provide equivalent protection. VBP complying with NFPA 58, §5 ~~such as~~ curbs or fences shall be arranged so they will not hamper free ventilation around the containers. It is permissible to locate a different storage container in the same location as a previous container where the crashpost complied with the regulation and had a valid permit to operate provided all other current requirements of Title 8 are complied with.

(3) Containers installed in battery shall not be installed with liquid and vapor lines connecting into common headers unless either:

(A) the working pressure of all such containers is at least equal to the vapor pressure of the product stored in any such container; or,

(B) check valves or other devices are installed in the system to prohibit the introduction of the higher-pressure product into the lower-pressure container.

### (b) Mounded Containers.

Containers shall not be mounded unless written permission to do so has been obtained from the Division.

In addition to the requirements of NFPA 58, ~~Section 3-2.4.7~~ the following construction, maintenance, and documentation provisions shall apply:

(1) Construction.

(A) Where containers are to be installed closer than 30 inches above surrounding grade, a moisture barrier to prevent the upward migration of potentially corrosive salts or acids shall be installed.

(B) Drainage tile or pipe shall be installed to prevent the accumulation of moisture within the insulating medium. Where a moisture barrier is installed, the drainage material shall be placed above that barrier.

(C) Relief-valve capacity and installation shall be that which is required for aboveground containers and shall comply with NFPA 58, ~~Section 3-2.6.3~~, as measured from the tank shell.

(D) All container-liquid and vapor-transfer openings shall be fitted with pneumatically-controlled internal-type valves incorporating excess-flow protection or spring-loaded backflow check valves. Remote emergency shutdown capability shall be provided on container installations in bulk and industrial plants of 2001 gallons or greater.

(E) Container valves and appurtenances shall be accessible for operation, repair, or maintenance without disturbing mounding material.

NOTE: Access crawlways shall be evaluated for compliance with the General Industry Safety Orders, Article 108.

(F) Prior to mounding, inaccessible plugged openings, joints, and other appurtenances shall be tested for leaks at operating pressure.

(G) Liquid level and pressure gauges shall be accessible visually and physically and shall be vented outside of the mounding.

(H) Mounded containers shall be protected against corrosion by coating the container with corrosion-resistant material approved for buried installations provided the material is applied in accordance with the manufacturer's recommendations. The employer/user shall submit to the Division a copy of the manufacturer's data for the coating material showing the method and procedures for coating prior to installation.

(I) All containers shall be cathodically protected and electrically isolated from connecting piping or electrically conductive structures in accordance with good engineering practice.

(J) Depth gauges shall be installed at intervals of not greater than 6 feet along the vertical center line of the container to visually indicate when insulating material becomes less than 1 foot in depth over the container.

(2) Maintenance Requirements.

(A) Filling densities shall be as required for aboveground containers.

(B) Voltage readings from the cathodic system shall be taken in accordance with NFPA 58 and recorded annually ~~and shall produce a negative voltage of at least 0.85 volts with reference to a saturated copper-copper sulfide half cell.~~

(C) All mounded containers shall be completely uncovered for an inspection of all external surfaces at intervals of at least once every 5 years. The intervals shall be extended when no failure in the cathodic protection has been detected, provided that every container shall be uncovered at least once every 30 years. Alternate methods of inspection may be used, e.g., UT, internal inspection.

(D) Where passive cathodic protection is provided, amperage readings shall be taken annually from each sacrificial anode. Where impressed current is used, amperage and voltage readings shall be reported at 6-month intervals.

(E) The depth gauges across the top of the container shall be observed annually to determine that a minimum of one-foot coverage of insulating material exists over the top of the entire container.

(F) Leak surveys shall be conducted annually using a combustible-gas indicator or comparably effective instrument to sample the air from the drainage system beneath the container and from test holes surrounding the container at intervals not greater than 10 feet.

(3) Documentation.

(A) The following documentation shall be maintained for the life of the system:

1. The construction requirements of this Section and of NFPA 58, ~~Section 3-2.4.7~~ shall be documented through the use of photographs and other appropriate means.

2. All tests required in this Section shall be recorded in a system log showing the date the tests were taken, the related readings, and the name of the person making the tests. These tests shall be available to the Division at any time for the purpose of inspection and verification and shall be retained for the life of the installation.

3. The owner or operator of a mounded container shall send a copy of the system log for that container to the Division's principal safety engineer each year during the month of June.

(c) Underground Containers.

Containers shall not be installed underground unless written permission to do so has been obtained from the Division.

In addition to the requirements of NFPA 58, ~~Section 3-2.4.8~~ the following construction, maintenance, and documentation provisions shall apply:

(1) Construction.

(A) Underground containers shall be protected against corrosion by coating the container with corrosion-resistant material approved for buried installations provided the material is applied in accordance with the manufacturer's recommendations. The employer/user shall submit to the Division a copy of the manufacturer's data for the coating material showing the method and procedures for coating prior to installation.

(B) All containers shall be cathodically protected and shall be electrically isolated from connecting piping or electrically conductive structures in accordance with good engineering practice.

(C) No tank used underground shall be installed aboveground until it has been inspected and found to be in compliance with requirements for an aboveground installation.

(2) Maintenance Requirements.

(A) Voltage readings from the cathodic system shall be taken in accordance with NFPA 58 and recorded annually ~~and shall produce a negative voltage of at least 0.85 volts with reference to a saturated copper-copper sulfite half cell.~~

(B) All underground containers shall be completely uncovered for an inspection of all external surfaces at intervals of at least once every 5 years. The intervals shall be extended when no failure in the cathodic protection has been detected, provided that every container shall be uncovered at least once every 30 years.

Alternate methods of inspection such as internal inspection and ultrasonic testing may be used to check and verify the integrity of the container in lieu of it being uncovered.

(C) Where impressed current is used, amperage and voltage readings shall be recorded at 6-month intervals.

(D) Leak surveys shall be conducted annually using a combustible-gas indicator or comparably effective instrument to sample the air from the tests holes surrounding the container at intervals not greater than 10 feet.

(3) Documentation.

(A) The following documentation shall be maintained for the life of the system:

1. The construction requirements of this Section and NFPA 58, ~~Section 3-2.4.8~~ shall be documented through the use of photographs and other appropriate means.

2. All tests required in this Section shall be recorded in a system log showing the date the tests were taken, the related readings, and the name of the person making the tests. These tests shall be available to the Division at any time for the purpose of inspection and verification and shall be retained for the life of the installation.

3. The owner or operator of a underground container shall send a copy of the system log for that container to the Division's principal safety engineer each year during the month of June.

(d) Partially Underground/Mounded Containers. Partially underground or partially mounded containers shall be prohibited.

(e) Fusible plugs and/or rupture discs are prohibited for any container installed or reinstalled after ~~the effective date of these orders~~ 1-3-1997.

### Credits

NOTE: Authority cited: Section 142.3, Labor Code. Reference: Section 142.3, Labor Code; and Section 13241, Health and Safety Code.

### HISTORY

1. Amendment filed 12-8-72 as procedural and organizational; effective upon filing (Register 72, No. 50).
2. Amendment filed 11-7-75; effective thirtieth day thereafter (Register 75, No. 45).
3. Amendment of subsection (a) filed 8-6-76; effective thirtieth day thereafter (Register 76, No. 32).
4. Amendment of section heading and section and new NOTE filed 12-4-96; operative 1-3-97 (Register 96, No. 49).
5. Amendment of subsections (a)(1) and (a)(2), repealer of subsection (a)(3), subsection renumbering and amendment of subsection (b)(1)(C) filed 1-30-2002; operative 3-1-2002 (Register 2002, No. 5).
6. Change without regulatory effect amending subsection (b)(1)(E) filed 5-7-2012 pursuant to section 100, title 1, California Code of Regulations (Register 2012, No. 19).

### **§478. ~~Skid Portable Storage Containers, and Trap Tanks~~ Movable Fuel Storage Tenders, and Containers on Transportation and Bulk Delivery Vehicles.**

---

(a) Unless installed in compliance with Section 477(a), skid portable storage containers and ~~trap tanks~~ movable fuel storage tenders shall not be used at any location for more than 180 days without written permission from the Division.

(b) Transportation tanks, or other tanks mounted on wheels, shall not be used in lieu of storage tanks or ~~skid tanks~~ portable storage containers without written permission from the Division. Such permission shall be granted for temporary use only and not to exceed 180 days.

(c) Cargo tank vehicles shall not be filled from other cargo tank vehicles or cargo tanks except under the direction of first responders in case emergency.

## Credits

NOTE: Authority cited: Section 142.3, Labor Code. Reference: Section 142.3, Labor Code; and Section 13241, Health and Safety Code.

## HISTORY

1. Amendment filed 12-8-72 as procedural and organizational; effective upon filing (Register 72, No. 50).
2. Amendment filed 11-7-75; effective thirtieth day thereafter (Register 75, No. 45).
3. Amendment of section heading and section and new NOTE filed 12-4-96; operative 1-3-97 (Register 96, No. 49).

## **§479. Installation of Tanks on Transportation and Bulk Delivery Vehicles. (Repealed)**

---

## Credits

## HISTORY

1. Amendment filed 12-8-72 as procedural and organizational; effective upon filing (Register 72, No. 50).
2. Amendment filed 11-7-75; effective thirtieth day thereafter (Register 75, No. 45).
3. Amendment of subsection (a)(3) filed 5-4-76 as procedural and organizational; effective upon filing (Register 76, No. 19).
4. New subsection (m) filed 12-14-76; effective thirtieth day thereafter (Register 76, No. 51).
5. Repealer filed 12-4-96; operative 1-3-97 (Register 96, No. 49).

## **§480. Pipes and Fittings for All Liquid Lines and for Vapor Lines Where the Pressure Exceeds ~~20~~ 30 PSI.**

---

(a) All pipe between the container and first shutoff valve shall be Schedule 80 (extra heavy). All fittings between the container and first shutoff valve shall be steel as required by Section 480(c).

Aboveground piping in excess of 1 1/2 inch pipe size may be Schedule 40 when used beyond the first shutoff valve, providing:

- (1) Threaded connections are used and the piping is used for vapor service only at less than 125 psi.
- (2) Welded connections are used and the piping is used for liquid or vapor service at less than 400 psi.

All other piping shall be Schedule 80.

Where used, flare nuts shall be of forged brass.

All welded piping shall be fabricated and tested in accordance with NFPA 58 ~~with the ANSI Standard Code for Pressure Piping, Section 3, Petroleum Refinery Piping B-31.3, 1993 Edition or equivalent.~~

(b) Piping outside of buildings may be either buried or installed aboveground and shall be well-supported and protected against mechanical injury. All underground piping shall be Schedule 80 and shall be buried not less than 18 inches below the surface of the ground, unless otherwise protected, and shall be protected from corrosion by approved corrosion-resistant material and by cathodic protection.

Voltage readings from the cathodic system shall be taken in accordance with NFPA 58 and recorded annually ~~and shall produce a negative voltage of at least 0.85 volts with reference to a saturated copper-copper sulfide half-cell.~~ Where impressed current is used, amperage and voltage readings shall be recorded at 6-month intervals.

(c) All steel fittings used with Schedule 80 pipe shall be Schedule 80 if butt welded, 3,000 pounds WOG if socket welded, and 2,000 pounds WOG forged steel if threaded. All other steel fittings shall have a rating of at least Schedule 40 if butt welded, and 2,000 pounds WOG if socket welded or threaded.

All steel valves and fittings shall have a steam rating of at least one hundred fifty (150) psi, ANSI standard, with a minimum WOG rating of 250 psi. Valves of material other than steel shall have a pressure rating of at least two hundred (200) psi steam, or four hundred (400) psi WOG. The manufacturer of LP-Gas valves shall stamp or otherwise permanently mark the valve body to indicate the pressure rating. Steam valves when used for LP-Gas service shall be refitted for such service. Valve seat material, packing, gaskets, etc., shall be resistant to the action of LP-Gas.

(d) The use of the following is prohibited:

(1) Valves of a design that will allow the valve stem to be removed without removal of complete valve bonnet.

(2) Valves with valve stem packing glands which cannot be repacked under pressure, unless there is another valve of acceptable type between them and the tank.

(3) Aluminum tubing.

(4) Pipe nipples used in lieu of couplings or flanges on aboveground tanks.

(5) Multivalves installed in aboveground ASME containers ~~without excess-flow valves and fixed dip tubes for use other than DOT cylinders.~~

(6) Installation of the required excess flow or backflow check valves indicated in NFPA 58 at a point outside of the container openings.

(e) In addition to the internal valves required in NFPA 58, ~~Section 2-3.3.2~~, all liquid and vapor connections shall be fitted with manually operated shutoff valves located as close to the container as practicable.



(f) Where containers are in liquid service or a combination of liquid and vapor service, all connections with manually operated shutoff valves shall be legibly labeled to indicate whether they communicate with the vapor or liquid space.

### **Credits**

NOTE: Authority cited: Section 142.3, Labor Code. Reference: Section 142.3, Labor Code; and Section 13241, Health and Safety Code.

### **HISTORY**

1. Amendment filed 4-1-77; effective thirtieth day thereafter (Register 77, No. 14). For prior history, see Register 75, No. 45.
2. Amendment of section, including repealer of table 480, and new NOTE filed 12-4-96; operative 1-3-97 (Register 96, No. 49).

### **§481. Pipes and Fittings for Vapor Lines Where the Pressure Is 20 PSI or Less. (Repealed)**

---

### **Credits**

NOTE: Authority cited and Reference: Section 142.3, Labor Code.

### **HISTORY**

1. Amendment filed 12-8-72 as procedural and organizational; effective upon filing (Register 72, No. 50).
2. Amendment filed 11-7-75; effective thirtieth day thereafter (Register 75, No. 45).
3. Amendment filed 4-1-77; effective thirtieth day thereafter (Register 77, No. 14).
4. Amendment of subsections (d) and (f) filed 4-13-82; effective thirtieth day thereafter (Register 82, No. 16).
5. Repealer filed 12-4-96; operative 1-3-97 (Register 96, No. 49).

### **§482. Hose Specifications. (Repealed)**

---

### **Credits**

### **HISTORY**

1. Amendment filed 12-8-72 as procedural and organizational; effective upon filing (Register 72, No. 50).
2. Amendment filed 11-7-75; effective thirtieth day thereafter (Register 75, No. 45).
3. Repealer filed 12-4-96; operative 1-3-97 (Register 96, No. 49).

### **§483. Pressure Gages. (Repealed)**

---

#### **Credits**

#### HISTORY

1. Amendment filed 12-8-72 as procedural and organizational; effective upon filing (Register 72, No. 50).
2. Repealer filed 12-4-96; operative 1-3-97 (Register 96, No. 49).

### **§484. ~~Vaporizer~~ Vaporizing and Mixing Equipment Installation.**

---

(a) Surge tanks, gas-air mix tanks, etc., containing vapor only, shall be located at least 3 feet from important buildings and property lines. Such tanks operating at pressures exceeding 20 psi shall be located not less than 10 feet from any building opening, whereas such tanks exceeding 501 gallons shall be located not less than 25 feet from any building opening.

(b) The use of direct-fired container heaters is prohibited.

#### **Credits**

NOTE: Authority cited: Section 142.3, Labor Code. Reference: Section 142.3, Labor Code; and Section 13241, Health and Safety Code.

#### HISTORY

1. Amendment filed 12-8-72 as procedural and organizational; effective upon filing (Register 72, No. 50).
2. Amendment filed 11-7-75; effective thirtieth day thereafter (Register 75, No. 45).
3. Amendment filed 4-1-77; effective thirtieth day thereafter (Register 77, No. 14).
4. Amendment of section and new NOTE filed 12-4-96; operative 1-3-97 (Register 96, No. 49).

### **§485. Safety Valves. (Repealed)**

---

(a) Safety relief valves shall be certified and stamped in accordance with the ASME and the National Board. Safety relief valves shall be inspected, maintained and replaced as recommended by the manufacturer where such recommendations are available. Safety relief valves shall be replaced at a maximum of 25 years from the date of installation.

## Credits

### HISTORY

1. Amendment filed 12-8-72 as procedural and organizational; effective upon filing (Register 72, No. 50).
2. Amendment filed 11-7-75; effective thirtieth day thereafter (Register 75, No. 45).
3. Amendment of subsection (f) filed 8-6-76; effective thirtieth day thereafter (Register 76, No. 32).
4. Amendment filed 4-1-77; effective thirtieth day thereafter (Register 77, No. 14).
5. Repealer filed 12-4-96; operative 1-3-97 (Register 96, No. 49).

## **§486. Regulators. (Repealed)**

---

## Credits

NOTE: Authority cited: Section 142.3, Labor Code. Reference: Section 142.3, Labor Code; and Section 13241, Health and Safety Code.

### HISTORY

1. New section filed 12-4-96; operative 1-3-97 (Register 96, No. 49).
2. Repealer filed 1-30-2002; operative 3-1-2002 (Register 2002, No. 5).

## **§487. Regulator Installation. (Repealed)**

---

## Credits

NOTE: Authority cited: Section 142.3, Labor Code. Reference: Section 142.3, Labor Code; and Section 13241, Health and Safety Code.

### HISTORY

1. New section filed 12-4-96; operative 1-3-97 (Register 96, No. 49).
2. Repealer filed 1-30-2002; operative 3-1-2002 (Register 2002, No. 5).

## **§488. ~~LP-Gas~~ LP-Gas Tank Inspection Fees.**

---

See the Division of Occupational Safety and Health's regulations contained in Chapter 3.2, Group 2, Title 8, California Code of Regulations. ~~The regulations for LP Gas tank inspection fees are reprinted in Appendix C of these orders.~~

### Credits

Note: Authority cited: Section 142.3, Labor Code. Reference: Section 142.3, Labor Code; and Section 13241, Health and Safety Code.

### HISTORY

1. Repealer and new section filed 3-28-78; effective thirtieth day thereafter (Register 78, No. 13). For history of former section, see Register 76, No. 32.
2. Amendment of section and NOTE filed 12-4-96; operative 1-3-97 (Register 96, No. 49).

### §489. Warning Signs.

---

(a) All containers in excess of 125 gallons, except transportation containers and fuel containers on motor vehicles, shall have the word "FLAMMABLE" on each side that is readily visible. The letters of this sign shall be in standard-type letters and shall have a height of at least 1/12 of the diameter of the container, but need not be in excess of 1 1/2 inches for containers of 500 gallons capacity or less or 4 inches for containers exceeding 500 gallons capacity.

(b) Warning signs with the words "NO SMOKING, OPEN FLAMES OR OTHER SOURCE OF IGNITION PERMITTED WITHIN \_\_\_\_\_ FEET" shall be applied on each side of the container in letters at least 1 1/2 inches high, in sharply contrasting colors, on each stationary container or on a sign posted adjacent to the container. This sign shall also be posted adjacent to all loading and unloading terminals located more than 50 feet from the container.

(c) When 2 or more containers are installed in battery, the requirement of Sections 489 (a) and (b) will be considered as being complied with when the required warning signs are prominently displayed on all 4 sides of such battery of containers.

NOTE: The distance shall be that shown on the following table:

<i>Volumetric capacity of Containers (in U.S. gallons)</i>	<i>Minimum distance from source of ignition</i>
125 to 500 inclusive	10 feet
501 to 2,000 inclusive	<del>25</del> <u>15</u> feet
Over 2,000	<del>50</del> <u>25</u> feet

(d) The warning signs required in Section 489(b) shall be posted on each exterior wall of each room or building used for filling or storage of cylinders.

(e) When LP-Gas and one or more other gases are stored or used in the same area, the containers shall be marked to identify their content. Markings shall be in compliance with ANSI Z48.1- 1992, "Method of Marking Portable Compressed Gas Containers To Identify the Material Contained."

### **Credits**

NOTE: Authority cited: Section 142.3, Labor Code. Reference: Section 142.3, Labor Code; and Section 13241, Health and Safety Code.

### **HISTORY**

1. Amendment of subsection (a) filed 5-4-77 as an emergency; effective upon filing (Register 77, No. 19). For prior history, see Register 76, No. 32.
2. Amendment of subsection (a) filed 8-18-77; effective thirtieth day thereafter (Register 77, No. 34.)
3. Amendment of section and new NOTE filed 12-4-96; operative 1-3-97 (Register 96, No. 49).

### **§490. Installation of Fuel Tanks for Motor Vehicles. (Repealed)**

---

### **Credits**

NOTE: Authority cited: Section 142.3, Labor Code. Reference: Section 142.3, Labor Code.

### **HISTORY**

1. Amendment of subsection (g)(1) filed 4-1-77; effective thirtieth day thereafter (Register 77, No. 14).
2. Repealer of subsections (h)(3) and (h)(4) filed 1-17-80; effective thirtieth day thereafter (Register 80, No. 3).
3. Amendment of subsection (g)(4) filed 7-8-85; effective thirtieth day thereafter (Register 85, No. 28).
4. Editorial reprinting of 7-8-85 order and correction of Register 85, No. 28 revision record sheet changing Chapter 3.5 to Chapter 4, Subchapter 1 (Register 85, No. 38).
5. Repealer filed 12-4-96; operative 1-3-97 (Register 96, No. 49).

### **§491. Installation of Fuel Tanks and Cylinders Used on Tar Pots, Weed Burners, Flame Cultivators, Etc. (Repealed)**

(a) LP-Gas tanks or cylinders used to furnish fuel to weed burners and flame cultivators, etc., shall be protected from radiant or convected heat from open flames or other burners by the use of a heat shield or by the location of the container(s) on the vehicle, such that the heat from the burner will not increase

the temperature of the tank more than 10 degrees Fahrenheit after one hour of operation of the burner at full capacity.

(b) The connection between fuel tanks and burners shall be extra-heavy steel pipe (Schedule 80), flexible metal tubing, or LP-Gas hose suitable for this service, and where exposed shall be adequately protected from physical damage and flame impingement. All main shutoff valves shall be accessible at all times while the unit is in normal operation. All shutoff valves shall be adequately protected from physical damage.

(c) In addition to the valves and controls used for normal operation, the liquid withdrawal opening in the container shall be equipped with one of the following to allow the operator of the vehicle to remotely shut down the flow of gas (100%) to the burners:

(1) An internal valve fitted for remote closure and automatic shutoff using thermal (fire) actuation.

(2) A positive shutoff valve that is located as close to the container as practical in combination with an excess flow valve installed in the container, plus an emergency shutoff valve that is fitted for remote closure and automatic thermal (fire) actuation that is installed downstream in the line as close as practical to the positive shutoff valve.

---

## Credits

### HISTORY

1. Repealer filed 12-4-96; operative 1-3-97 (Register 96, No. 49).

## §492. Use of Tanks and Cylinders of Less than 60 U.S. Gallons. (Repealed)

---

## Credits

### HISTORY

1. Amendment filed 12-8-72 as procedural and organizational; effective upon filing (Register 72, No. 50).
2. Amendment of subsections (a) and (c) and new subsection (f) filed 10-17-75; effective thirtieth day thereafter (Register 75, No. 42).
3. Amendment filed 11-7-75; effective thirtieth day thereafter (Register 75, No. 45).
4. Amendment filed 4-1-77; effective thirtieth day thereafter (Register 77, No. 14).
5. Repealer filed 12-4-96; operative 1-3-97 (Register 96, No. 49).

## §493. Storage or Utilization of LP-Gas Within Buildings. (Repealed)

---

## Credits

### HISTORY

1. Amendment filed 12-8-72 as procedural and organizational; effective upon filing (Register 72, No. 50).
2. Amendment filed 11-7-75; effective thirtieth day thereafter (Register 75, No. 45).
3. Amendment filed 4-1-77; effective thirtieth day thereafter (Register 77, No. 14).
4. Repealer filed 12-4-96; operative 1-3-97 (Register 96, No. 49).

### **§494. Repairs and Alterations. (Repealed)**

---

~~(a) No repairs or alterations involving flame, arc, or other method of welding shall be made on any container cylinder, or system unless such container, cylinder, or system shall first have been certified as gas free or oxygen free by a qualified person.~~

~~(b) No repair or alteration affecting the safety of any container or cylinder shall be made until the contemplated repair or alteration has been authorized by a qualified inspector. The owner or user of the LP-Gas container shall ensure that the repair or alteration is performed by a company with a valid ASME "U" or a National Board "R" Certificate of Authorization. The exchange or interchange of valves, fittings, and accessories intended for the same purpose shall not be considered a repair or alteration.~~

~~(c) No container or cylinder that has been subjected to a fire shall be returned to service until it has been inspected by a qualified inspector and found to be safe.~~

~~Any container or cylinder which has suffered mechanical damage causing dents or other deformation exceeding a depth of 1 1/2 times the thickness of the deformed head or shell or two percent of the container diameter, whichever is greater, shall be re-formed to its original shape or otherwise repaired as provided in these Orders.~~

~~(d) Any vessel requiring repair or alteration or that has been subjected to a fire shall not be recharged until it has been retested in accordance with the requirements for its original hydrostatic test and found to be suitable for continued service, when such test is deemed necessary by the qualified inspector.~~

~~(e) The owner or user of the LP-Gas container shall ensure that all repairs or alterations affecting the safety of LP-Gas tanks are reported to the Division within 21 days by the ASME "U" or National Board "R" certificate holder making such repairs or alterations using the appropriate National Board Form, "R-1", Report of Welded Repair, or "R-2", Report of Alteration, or equivalent (See Appendix D). The owner or user shall ensure that the qualified inspector stamps his/her certificate of competency number adjacent to all welded repairs authorized by him/her, except that in the case of repairs to quenched and tempered steels, this number need not be stamped. This exception shall be noted in the inspector's report.~~

~~(f) Any welding necessary when making repairs or alterations to containers shall be done by a welder qualified in accordance with Section IX of the ASME Code in the position or positions used in making the repair.~~

~~(g) Repairs to DOT cylinders shall be made under DOT regulations and control in accordance with the requirements of 49 CFR Section 173.34.~~

### **Credits**

NOTE: Authority cited: Section 142.3, Labor Code. Reference: Section 142.3, Labor Code; and Section 13241, Health and Safety Code.

### **HISTORY**

1. Amendment filed 12-8-72 as procedural and organizational; effective upon filing (Register 72, No. 50).
2. Amendment of section and new NOTE filed 12-4-96; operative 1-3-97 (Register 96, No. 49).
3. Amendment filed 1-30-2002; operative 3-1-2002 (Register 2002, No. 5).

## ***Article 6. Anhydrous Ammonia***

---

### **INTRODUCTION**

The provisions of Article 6 need not apply to anhydrous ammonia installations up to the point of delivery to a transportation tank in plants manufacturing this product or in refrigeration plants where ammonia is used solely as a refrigerant; provided, however, that tanks used in such plants be designed and constructed in accordance with the provisions of Article 2, and shall be maintained and operated in accordance with the provisions of Article 4 of these Orders.

### **HISTORY**

1. Amendment of introduction filed 3-28-75; effective thirtieth day thereafter (Register 75, No. 13).

### **§500. Approval of Devices.**

---

(a) All devices which are used in anhydrous ammonia service shall be of a type and construction suitable for the use to which they are put. They shall preferably be listed by at least one nationally recognized testing laboratory such as, but not limited to, Underwriters Laboratories, Inc. and Factory Mutual Engineering Corp. (For the purposes of this paragraph, the word "listed" means that equipment is of a kind mentioned in a list which is published by a nationally recognized laboratory which makes periodic inspection of the production of such equipment, and states such equipment meets nationally recognized standards or has been tested and found safe for use in a specified manner.)



The Division may approve or accept devices upon satisfactory evidence that they are designed and constructed for safe operation in anhydrous ammonia service.

Drawings and calculations for custom-built devices must be submitted to the Division for acceptance. Both the drawings and calculations must be signed by a registered professional engineer.

### **Credits**

#### HISTORY

1. Amendment filed 12-8-72 as procedural and organizational; effective upon filing (Register 72, No. 50).
2. Amendment filed 3-28-75; effective thirtieth day thereafter (Register 75, No. 13).

### **§501. Installation of Aboveground Storage Tanks for Other Than Refrigeration Service.**

---

(a) Stationary tanks shall be installed aboveground on firm masonry or concrete foundations, or on full length skids providing a bearing area limiting foundation loadings to not more than 2,000 pounds per square foot. Unless supported by continuous skids welded to pads on the tank shell, aboveground horizontal storage tanks shall have no more than 2 points of support longitudinally. Where necessary, tanks shall be securely anchored or weighed to prevent floating.

A tank may be installed on saddles, directly on concrete foundations, or it may be supported by properly designed metallic structural supports. When the tank is installed directly on concrete foundations, a corrosion pad shall be provided at the points of contact with the foundation. These corrosion pads shall be at least 3/16 inch thick, and shall have a width at least equal to the width of the foundation at the point of contact with the tank, but in no case shall they be less than 8 times the shell thickness in width.

When corrosion pads or pad-type steel supports are used, the pad shall have rounded or semielliptically shaped ends, and shall be attached to the shell with a continuous seal weld. Corrosion pads shall be not less than 1/4 the circumference of the shell in length.

Unless installed on concrete pads, skid tanks shall be placed on engineered soil or road base topped with well-drained gravel or oiled sand, capable of supporting 2,000 pounds per square foot.

Sufficient space shall be provided between stationary storage tanks to permit access for fire fighting. This space shall not be less than 5 feet for tanks over 1,200-gallon capacity. Tanks exceeding 1,200-gallon capacity shall be so installed that the bottom outside surface of the tank is at least 12 inches above ground level.

(b) All tanks over 1,200-gallon capacity shall be installed on foundations in such a manner as to permit expansion and contraction. Every tank shall be so supported as to prevent the concentration of excessive loads on the tank at the points of support. All foundations and fastenings shall be designed to provide reasonable safety under imposed loadings, including wind, earthquake, vibrations, etc.

(c) Containers shall be located outside of buildings, or in buildings or sections thereof especially equipped for this service. Consideration shall be given to the adverse health effects of ammonia, as well as the adjacent fire hazards, when selecting the location for a storage container.

Storage areas shall be kept free of readily ignitable materials such as waste, weeds, and long dry grass.

Stationary storage tanks shall be located with relation to property lines, residential buildings, highways, etc., in accordance with the following table:

<i>Capacity of tank in U.S. gallons</i>	<u><i>Minimum distance (feet) from tank to</i></u>		
	<i>Line of property adjoining which may be built upon</i>	<i>Highway or main track of railroad</i>	<i>Residential building</i>
1,200 and less	50	25	50
Over 1,200 to and including 30,000	50	50	50
Over 30,000 to and including 70,000	65	50	65
Over 70,000 to and including 500,000	100	50	100
Over 500,000	150	50	150

<i>Capacity of tank in U.S. gallons</i>	<u><i>Minimum distance (feet) from tank to</i></u>		
	<i>Any Building or area used by the public for deliberation, worship, education, entertainment, amusement, or awaiting transportation</i>	<i>Hospital, jail or other similar institutions</i>	<i>Open well, reservoir, or other source of potable water</i>
1,200 and less	250	750	50
Over 1,200 to and including 30,000	400	1,000	100
Over 30,000 to and including 70,000	520	1,300	100
Over 70,000 to and including 500,000	800	2,000	200
Over 500,000	1,000	2,500	200

Electrical equipment and wiring for use in ammonia installations shall be general purpose or weather resistant as appropriate.

Electrical systems shall be installed and maintained in accordance with the Electrical Safety Orders.

(d) Where vehicle impact is possible or likely stationary tanks shall be protected against vehicle damage by a rugged fence, suitable crash posts, curbs, or other acceptable protection. All storage tanks located where unauthorized tampering is possible shall be surrounded with a rugged steel fence or equivalent, or all liquid and vapor outlets shall be kept effectively locked when not in use.

(e) All stationary storage tanks exceeding 1,200 gallons capacity shall have the loading and unloading connections secured to a concrete bulkhead or equivalent designed to withstand a horizontal pull of not less than 2,000 pounds in any direction, unless other suitable protection is provided. This bulkhead shall not be located underneath the tank. The loading and unloading connections shall be firmly secured to this bulkhead and the piping between the bulkhead and tank shall be installed in a manner to provide for expansion, contraction, jarring, vibrations, settling, etc. For skid tanks exceeding 1,200 gallons capacity, such loading and unloading connections shall be securely fastened to the skid or to the tank supports.

NOTE: 2,000 pounds may not be adequate for all sizes of loading and unloading hoses and connections.

(f) Where excess-flow valves [See Section 507(e)] are used, liquid and vapor lines shall be at least full size from the excess-flow valve in the tank to the point of discharge or an additional excess-flow valve or equivalent shall be located as close to the point of pipe size reduction or other restriction as is practical, unless the excess-flow valve in the tank is designed to operate at the reduced flow condition, in which case the excess-flow valve in the tank may suffice.

Where excess-flow valves are used and 2 or more tanks are installed in battery, with common loading and/or unloading lines, the common liquid and vapor lines shall be fitted with excess-flow valves or equivalent (unless the common line has a cross-sectional area equal to or in excess of the combined areas of the individual tank lines; or unless the excess-flow valves are designed to operate at the reduced flow condition, in which case the excess-flow valve in the tank may suffice). Where additional excess-flow valves are used in common loading and/or unloading lines, the additional excess-flow valve or equivalent shall be located as close to the point of restriction as practical.

NOTE: A quick-closing manually operated valve may be considered equivalent to an excess-flow valve at the point of pipe size reduction or other restriction providing:

(1) It is equipped with a means of closing the valve manually from a point remote from the delivery connection.

(2) The loading and/or unloading line in which it is located is secured to a bulkhead complying with Section 501 (e).

(3) The quick-closing valve is in the pipeline on the tank side of the bulkhead.

(g) Tanks installed in battery shall be so installed that the top surfaces of the tanks are substantially in the same horizontal plane.

(h) The following minimum equipment shall be installed, properly maintained, and readily available for use at all stationary storage tanks in readily accessible locations.

(1) At least two full face respiratory devices in compliance with Section 5144; preferably one self contained breathing apparatus, and one NH<sub>3</sub> gas mask with spare canister.

(2) One pair NH<sub>3</sub> resistant gloves.

(3) One pair NH<sub>3</sub> resistant boots.

(4) NH<sub>3</sub> resistant pants and jacket and/or slicker.

(5) One quick-acting deluge shower and bubble fountain or other method of simultaneously washing both eyes with clean water.

The minimum water supply shall be a 50-gallon container of clean water.

(6) One first-aid kit in compliance with Section 3400 or 3439.

(7) One fire extinguisher conforming to the provisions of California Administrative Code, Title 19, Chapter 1, Subchapter 3, and having a rating of not less 40B-C.

The employer shall have a program of periodic inspection of the above emergency equipment to maintain it in serviceable condition.

### **Credits**

#### **HISTORY**

1. Amendment filed 12-8-72 as procedural and organizational; effective upon filing (Register 72, No. 50).
2. Amendment of subsections (a), (c), (d), and (h) filed 3-28-75; effective thirtieth day thereafter (Register 75, No. 13).
3. Amendment of subsection (a) filed 8-6-76; effective thirtieth day thereafter (Register 76, No. 32).
4. Amendment of subsection (f) filed 4-1-77; effective thirtieth day thereafter (Register 77, No. 14).

### **§502. Warning Signs.**

---

(a) Except as noted in Section 502 (b), all anhydrous ammonia tanks 60 gallons capacity or more shall have warning signs provided on at least 2 sides with the words "Caution -- Ammonia" in sharply contrasting colors, with letters at least 1/12 of the tank diameter in height, but need not be in excess of 1 1/2 inches for tanks 500 gallons capacity or less or 4 inches for tanks exceeding 500 gallons capacity.

(b) All tanks used for the transportation of ammonia on the highways shall be marked as specified by the DOT and adopted by Section 1222, California Administrative Code, under authority of Section 34500, Vehicle code. These markings also will be acceptable to the Division in lieu of the markings required under Section 502 (a) for such tanks in off-highway service.

(c) Uninsulated containers shall have a highly reflective surface maintained in good condition.

### **Credits**

#### HISTORY

1. Amendment filed 12-8-72 as procedural and organizational; effective upon filing (Register 72, No. 50).
2. New subsection (c) filed 3-28-75; effective thirtieth day thereafter (Register 75, No. 13).

### **§503. Portable Tanks.**

---

(a) Portable tanks installed as permanent installations for periods of time exceeding 90 days shall be in compliance with Section 501.

Portable tanks filled at point of use shall be installed substantially level. A safe and accessible source of clean water (minimum 5 gallons) shall be immediately available to enable an employee to wash his eyes in case of accidental sprays or spillage. If a container is used, it shall have a suitable opening to permit the application of water to flush the eyes.

(b) Portable tanks shall comply with these orders, and legs or other supporting structures shall be secured to tanks in accordance with the code or rules under which the tank is designed and built, and shall be designed to withstand a loading in any direction equal to the loaded weight of the tank when filled to the maximum permissible level with a factor of safety of at least 8.

(c) Fittings on all portable tanks shall be installed in recessed wells or otherwise protected to prevent damage to the fittings during transportation and use.

(d) When portable tanks are transported from 1 location to another, they shall be securely fastened to the transporting vehicle.

(e) When containers are mounted on four-wheel trailers, care shall be taken to insure that the weight is distributed evenly over both axles.

(f) When the cradle and the tank are not welded together suitable material shall be used between them to eliminate metal-to-metal friction.

### **Credits**

#### HISTORY

1. Amendment filed 12-8-72 as procedural and organizational; effective upon filing (Register 72, No. 50).
2. New subsections (e) and (f) filed 3-28-75; effective thirtieth day thereafter (Register 75, No. 13).
3. Editorial correction of subsection (a) (Register 95, No. 45).

#### **§504. Installation of Tanks on Transportation and Bulk Delivery Vehicles.**

---

(a) Transportation tanks mounted on truck or trailer frames shall be placed on saddles or bolsters with the center of gravity as low as possible. Such saddles, bolsters, and/or other fastenings shall be designed to withstand a loading in any direction equal to the loaded weight of the tank when filled to the maximum permissible level with a factor of safety of at least 8. Transportation tanks of the so-called "frameless-type" shall not be used in anhydrous ammonia service until the design of the tank and tank supports has been submitted to the Division and found acceptable. The installation must also comply with DOT requirements.

All transportation trailers shall be firmly and securely attached to the vehicle drawing them by means of suitable drawbars supplemented by a safety chain (or chains) or safety cables.

Every transportation trailer or semitrailer shall have a reliable system of brakes, and adequate provision shall be made to operate the brakes from the driver's seat.

Every transportation trailer shall be equipped with self-energizing brakes.

Transportation trailers shall be so designed that the towed vehicle will follow substantially in the path of the towing vehicle and will not whip or swerve dangerously from side to side.

Where a fifth wheel is employed, it shall be ruggedly designed, securely fastened to both units, and equipped with a positive locking mechanism which will prevent separation of the two units except by manual release.

(b) Every transportation tank shall be protected by a suitable steel bumper attached to the vehicle chassis or equivalent.

(c) All fittings on transportation tanks not protected by the vehicle frame shall be located in recessed wells or otherwise suitably guarded. Any such guards shall be designed to minimize the possibility of rupturing the tank head or ~~shell~~ shell in case of vehicular accident. The recessed well, if used, shall be of sufficient size and depth that the top of all fittings will be located below the tank shell or head line. The recessed well for safety relief valves shall be located at the top center of the tank and shall be equipped with an unlocked hinged cover or equivalent.

(d) No anhydrous ammonia piping or valves shall be installed within the cab or driver's compartment of a truck.

(e) All piping and fittings on the bottom of transport and bulk delivery tanks shall be adequately guarded.

(f) All tank trucks and all trucks pulling tank trailers used to transport anhydrous ammonia over 1,200 gallons water capacity shall be equipped with the following minimum safety equipment which shall be properly maintained and readily available for use:

(1) One pair of NH<sub>3</sub> resistant gloves.

(2) Full face mask for ammonia service.

(3) One fire extinguisher conforming to the provisions of Article 157 of the General Industry Safety Orders and having a rating of not less than 20B-C.

(4) A container of not less than 5 gallons of fresh water, so located as to permit immediate application. This container shall have a suitable opening to permit rinsing of eyes.

(g) Each liquid withdrawal opening 2 inches nominal pipe size or larger on transportation tanks and bulk delivery vehicles over 1,200 gallons capacity shall be fitted with a remotely controlled internal shutoff valve of the type listed in Sections 507 (e)(3) through (5). Such tanks over 3,500 gallons capacity shall have 2 remote stations for the valve controls, 1 at each end of the tank and diagonally opposite each other.

One control mechanism at each control station may be used to operated all such remotely controlled valves.

All replacement valves for the above service shall comply with these Orders, if the openings in the tank are adaptable for conversion.

(h) Where excess-flow valves [See Section 507 (e)(2).] are used, all liquid and vapor lines shall be at least full size from the excess-flow valves in the tank to the point of discharge or an excess-flow valve or equivalent shall be located as close to the point of pipe size reduction or other restriction as is practical, unless the excess-flow valve in the tank is designed to operate at the reduced flow conditions, in which case the excess-flow valve in the tank may suffice.

Where excess flow valves are used on tank trucks having 2 or more tanks with common loading and/or unloading lines, the common liquid or vapor lines shall be fitted with an excess-flow valve or equivalent in the common line in addition to the excess-flow valve in the tank opening (unless the common line has a cross-sectional area equal to or in excess of the combined areas of the individual tank lines or unless the excess flow valves in the tank are designed to operate at the reduced flow condition, in either of which case the excess-flow valve in the tank may suffice). Where additional excess-flow valves are used in common loading and/or unloading lines, the additional excess-flow valve or equivalent shall be located as close to the point of restriction as is practical.

NOTE: A quick-closing manually operated valve may be considered equivalent to an excess-flow valve at the point of pipe size reduction or other restriction providing:

(1) It is equipped with a means for closing the valve manually from a point remote from the transfer hose connection.

(2) The loading and/or unloading line in which it is located is secured to the tank or vehicle framework as required by Section 504 (i).

(3) The quick-closing valve is located on the tank side of the structure used to secure the line or lines to the tank or vehicle frame.

(i) All liquid and vapor lines shall be adequately secured to the vehicle frame or tank. The device used to secure the lines shall be so designed that it will withstand the load imposed by the strongest hose and hose fitting to be used in the transfer operations without breaking, or 2,000 pounds, whichever is greater.

(j) All piping and fittings on transport and bulk delivery tanks shall be adequately guarded. The use of anhydrous ammonia hose between the tank and the transfer hose connection shall be limited to not more than 3 sections of metallic hose not over 24 inches in length in each liquid and vapor line. Such lengths of hose shall be used only where necessary to provide flexibility and shall not have 1 section of hose connected to another section of hose. Each section shall be so installed that it will be protected against mechanical damage and be readily visible for inspection. The manufacturer's identification required in Section 510 (b) shall be retained on each section.

(k) All transportation tanks shall be equipped for spray loading (filling in the vapor space), with an approved vapor return valve of adequate capacity.

#### HISTORY:

1. Amendment of subsections (g), (h) and (j) filed 12-8-72 as procedural and organizational; effective upon filing (Register 72, No. 50).

2. Amendment of subsections (a) and (f) and new subsection (k) filed 3-28-75; effective thirtieth day thereafter (Register 75, No. 13).

3. Repealer and new subsection (f) filed 8-6-76; effective thirtieth day thereafter (Register 76, No. 32).

#### **§505. Installation of Mobile Storage Tanks.**

---

(a) Mobile storage tanks shall meet the requirements of Section 504 except that:

(1) The design of saddles, bolsters, and/or other fastenings may be based on the empty weight of the tank for other than vertical loadings. (2) In addition to the requirements of Section 504 (f), there shall be available a container of not less than 50 gallons of fresh water unless there is immediately available another safe, reliable, and accessible source of water.

(b) When containing NH<sub>3</sub> liquid, mobile storage tanks shall be located in accordance with Section 501(c).



(c) Mobile storage tanks shall be maintained substantially level and be securely blocked against accidental movement and shall be adequately supported independently of the wheels when containing NH<sub>3</sub> liquid.

(d) Only flexible connections shall be made to mobile storage tanks. No permanent piping to other installations is permitted. The loading and unloading connections shall be securely fastened to the vehicle frame or to the tank supports.

(e) All liquid shall be removed from mobile storage tanks before being moved to a new location.

(f) Unless surrounded by a rugged steel fence or equivalent, all liquid and vapor outlets shall be kept effectively locked when unattended.

(g) Transportation tanks shall not be used as mobile storage tanks without written permission from the Division, unless they are in full compliance with both Sections 504 and 505.

### **Credits**

#### HISTORY

1. Amendment of subsection (b) filed 12-8-72 as procedural and organizational; effective upon filing (Register 72, No. 50).

### **§506. Installation of Tanks Mounted on Farm Machinery.**

---

(a) Tanks or cylinders used to furnish anhydrous ammonia to agricultural applicator tanks and tanks used on applicators, etc., shall be so installed that the bottom of the container and/or any outlet connection, including hose, shall not be lower than the lowest horizontal edge of the vehicle axle when fully loaded. These tanks shall be secured to prevent jarring loose, slipping, or rotating of the tanks while in service. Such supports and fastenings shall be designed to withstand a loading in any direction equal to the loaded weight of the tank when filled to the maximum permissible level with a factor of safety of at least 8.

Field welding where necessary, shall be made only on nonpressure parts that were installed by the manufacturer of the tank.

(b) The connections between the applicator tank and pressure-reducing valve shall be extra heavy fittings and Schedule-80 pipe, high-pressure anhydrous ammonia hose (1750 psi minimum bursting pressure), or equivalent, and where exposed, shall be protected against physical damage. All main shutoff valves shall be readily accessible while the unit is in normal operation. All shutoff valves shall be suitably protected against physical damage.

(c) While in use on farm machinery, each skid tank, applicator tank, or combination thereof shall have securely attached a container holding not less than 5 gallons of fresh water. This container shall have a suitable opening to permit the application of water to flush the eyes.

The container of fresh water required by this subsection may be attached to the tractor or other source of power used to tow the vehicle or device on which the tank is used.

(d) All trailers shall be securely attached to the vehicle drawing them by means of drawbars supplemented by suitable safety chains.

(e) A trailer shall be constructed so that it will follow substantially in the path of the towing vehicle and will not ship or swerve dangerously from side to side.

## Credits

### HISTORY

1. Amendment of subsection (a) and new subsections (d) and (e) filed 3-28-75; effective thirtieth day thereafter (Register 75, No. 13).

## **§507. Piping, Valves, and Fittings for Liquid and Vapor Lines.**

---

(a) All pipe between the tank and first shutoff valve shall be at least Schedule 80.

All fittings between the tank and the first shutoff valve shall be steel as required by Section 507 (c), first paragraph.

Aboveground piping in excess of 1 1/2-inch pipe size may be Schedule 40 when used beyond the first shutoff valve provided welded, or welded and flanged connections are used.

All other piping shall be Schedule 80.

All piping shall be tested after assembly and proved free of leaks at a pressure of not less than its normal operating pressure or 150 psi, whichever is greater.

Flammable material shall not be used for the installation acceptance pressure test.

All welded piping shall be fabricated and tested in accordance with ~~the ANS Standards Code for Pressure Piping, Section 3, Petroleum Refinery Piping B-31.3~~ ASME B31.3, 1966 or equivalent.

All refrigerated piping shall conform to the ~~Refrigeration Piping Code, American National Standards Institute, B-31.5-1966 with addenda B-31.1a-1968~~ as it applies to ammonia ASME B31.5.

Hose shall not be used in lieu of piping between the tank and loading and/or unloading connection, except that a section of metallic hose, not to exceed 24 inches in length may be used in each pipeline to provide flexibility and except as provided in Section 504 (j). The manufacturer's identification required in Section 510 (b) shall be retained on each section.

(b) All piping shall run as directly as practical, with suitable provision for expansion, contraction, jarring, vibrations, and settling. Piping may be either buried or installed aboveground, and shall be well supported and protected against physical damage. All underground piping shall be buried not less than 18 inches below the surface of the ground unless otherwise protected, and shall be adequately coated or otherwise protected against corrosion. Pipe coated as follows will be considered acceptable.

(1) Clean and prime.

(2) Coat with asphalt enamel.

(3) Wrap with forty-pound felt.

(4) Coat with asphalt enamel.

(5) Wrap with forty-pound felt.

(6) Coat with asphalt enamel.

(7) Wrap with Kraft paper.

Equivalent wrapping will be accepted at the discretion of the Division.

(c) All steel fitting used with Schedule 80 pipe shall be Schedule 80 if butt welded, 3,000 pound WOG if socket welded, and 2,000 pound WOG forged steel if threaded.

All other steel fittings shall have a rating of at least Schedule 40 if butt welded and 2,000 pound WOG if socket welded or threaded. Threaded connections shall not be seal welded.

Joint compounds shall be resistant to ammonia.

All other valves and fittings shall be of a type suitable for use with anhydrous ammonia and shall have a pressure rating of at least 400 psi WOG. Valve seat material, packing, gaskets, etc., shall be suitable for anhydrous ammonia service.

(d) The use of the following is prohibited:

(1) Valves, cocks, and pipe fittings of semisteel other than ASTM Specification Nos. A 536-67, Grade 60-40-18; A 395-68; A 445-66; A 47-68, Grade 35018; unless they have a pressure rating of not less than 600 psi WOG. In no case shall valves of semisteel other than the 4 ASTM Specifications listed above be used for primary stop valves.

Cast iron fittings made specifically for anhydrous ammonia service, meeting ASTM A-126-66 class B or C, may be used for secondary service if they have a service rating of at least 600 psi.

(2) Street ells and screwed service tees unless they are extra-heavy forged construction.

(3) Valves of a design that will allow the valve stem to be removed without removal of the complete valve bonnet, unless the flow is restricted by an inlet orifice to not more than 54 drill gage size.

(4) Ordinary solid-wedge-type gate valves unless there is another stop valve of acceptable type between the gate valve and tank.

(5) Valves with valve stem packing glands which cannot be repacked under pressure, unless there is another valve of acceptable type between it and the tank.

(6) Threaded aluminum fittings and/or adapters that are required to be connected or disconnected as part of the filling or transfer operation.

(7) Copper and brass pipe, fittings, valves, etc.

(8) Pipe, fittings, etc., that are galvanized or otherwise plated with material which is attacked by ammonia where such plating or galvanizing is exposed to ammonia.

(e) Except for service valves, safety relief valves, and gaging connections, all liquid and vapor connections shall have 1 of the following installed directly in the tank connections:

(1) Connections up to and including 4-inch pipe size:

(A) A back-pressure check valve.

(B) An excess-flow valve.

Excess flow valves shall be designed with a bypass, not to exceed a No. 60 drill-size opening to allow equalization of pressures.

All excess flow valves shall be plainly and permanently marked with the name or trademark of the manufacturer, the catalog number, and the rated capacity.

(C) A manually operated check valves (internal valve) equipped with means for closing the valve from a point remote from the delivery connection and with such control mechanism fitted with a fusible section having a melting point of 208 degrees Fahrenheit to 220 degrees Fahrenheit which will cause the valve to close automatically in case of fire.

(D) A positive check valve (internal valve) which can be operated manually and which will close automatically on excess-flow conditions and which can be closed manually from a point remote from the delivery connections. Such valve shall also incorporate a fusible section as required in Section 507 (e)(1)(C) which will cause the valve to close automatically in case of fire.

(E) A positive check valve (internal valve) which is normally closed and which is opened by pump discharge pressure and which can be closed manually from a point remote from the delivery connections. Such valve shall close automatically with a reduction of pump discharge pressure and shall also incorporate a fusible section as required in Section 507 (e)(1)(C) which will cause the valve to close automatically in case of fire.

NOTE: Service valve as used in this order is limited to vapor valves screwed into vessel outlets not larger than 3/4-inch pipe size and having an inlet internal diameter in the valve body not exceeding the internal diameter of a 1/2-inch Schedule 80 pipe.

(2) Valves larger than 4 inch pipe size need not be installed directly in a tank connection, under the following conditions:

(A) The valve must be installed at the first flange or welded joint immediately outside the container in such a manner that any undue strain beyond the valve will not cause breakage between the tank and the valve.

(B) Automatically or remotely controlled valves, or both, of the fail safe type, shall be used. They must also be capable of manual operation.

(C) Piping between the tank and the valve shall be at least Schedule 120.

(D) Acceptance of the valves by the Division must be requested prior to installation.

(E) Where cables are used for remote operation, the control must be fitted with a fusible section having a melting point of 208 degrees Fahrenheit of 220 degrees Fahrenheit, which will cause the valve to close automatically in case of fire.

(f) In addition to the valves required in Section 507 (e), all liquid and vapor connections other than safety relief valve and gaging connections shall be fitted with a manually operated shutoff valve located:

(1) As close to the tank as practicable in all pipelines on connections not included in Section 507 (f)(2) or (3).

(2) In the loading and/or unloading pipelines between the tank and the pump, compressor, meter, or bulkhead, whichever is nearest the tank and in each branch line where it leaves a loading and/or unloading line. This applies only to pipelines on stationary tanks having the loading and/or unloading lines secured to bulkheads specified in Section 501 (e) and having valves complying with Section 507 (e)(1)(D) or (E) installed in the tank connections of such pipelines.

When a pump is attached directly to a valve complying with Section 507 (e)(1)(D) or (E), the manually operated shutoff valve required by this Order may be located between said pump and the meter or bulkhead, whichever is nearest the tank.

(3) In the loading and/or unloading pipelines between the tank and the device used to secure the pipeline as required in Section 504 (i). This applies only to pipelines on transportation tanks having valves complying with Section 507 (e)(1)(D) or (E) installed in tank connections of such pipelines.

(g) Every liquid pipeline or hose that can be isolated by 2 or more stop valves shall have a safety relief valve installed in the pipeline or hose to prevent excessive hydrostatic pressure. The safety relief valve required by this subsection shall start to discharge at not less than 300 psi, nor more than 400 psi, and it must relieve to the atmosphere at a safe point of discharge.

(h) All valves, regulators, gaging, and other tank accessory equipment shall be protected against physical damage.

(i) All tank connections requiring manually operated shutoff valves shall be labeled or tagged to indicate whether they communicate with the liquid or vapor space.

(j) The liquid fill line used to transfer anhydrous ammonia from transportation tanks exceeding 3,500 gallons capacity to storage tanks exceeding 2,000 gallons capacity shall be equipped with a backflow check valve to prevent discharge of anhydrous ammonia from the receiving tank in case of hose rupture. This is not intended to prevent transferring anhydrous ammonia from containers, other than transportation tanks exceeding 3,500 gallons capacity, into storage tanks through the load-out line.

(k) All tanks shall be equipped with vapor return valves.

### **Credits**

#### HISTORY

1. Amendment filed 12-8-72 as procedural and organizational; effective upon filing (Register 72, No. 50).

2. Repealer of subsection (e) and new subsection (e) filed 8-30-74; effective thirtieth day thereafter (Register 74, No. 35).

3. Amendment of subsections (a), (c), (d), (e), (g) and new subsection (k) filed 3-28-75; effective thirtieth day thereafter (Register 75, No. 13).

4. Repealer and new subsections (e) and (f) filed 8-6-76; effective thirtieth day thereafter (Register 76, No. 32).

### **§508. Gaging Devices.**

---

(a) A permanent dip pipe shall be installed in all tanks designed to be filled by volume, and shall be of such length that it will indicate when the tank is 86 1/2 percent full. The fixed dip pipe required in this order shall be permanently installed in the tank.

Each applicator container shall have a fixed liquid-level gage.

(b) Each tank filled by volume shall be equipped with a liquid level gaging device, such as a rotary gage, a slip tube, an automatic gage, a magnetic gage, or a series of fixed dip pipes, to show the liquid level in the tank at any time. This gaging device shall be in addition to the fixed dip pipe required in Section 508 (a).

A thermometer well shall be provided in all storage tanks over 1,200 gallons capacity not equipped with a fixed dip pipe, and in all transportation tanks.

(c) Liquid level gaging devices that require bleeding of the product to the atmosphere, such as rotary gages, dip pipes, or slip tubes, shall be so designed that the maximum opening of the bleeder valve is not larger than No. 54 drill size.

(d) Liquid level gaging devices shall be designed for a working pressure of not less than 300 psi ANS rating.

(e) Tubular-type gage glasses shall not be used.

(f) Each transportation tank exceeding 1,200 gallon capacity shall have a pressure gage installed with the dial graduated to approximately double the operating pressure but in no case less than 1.2 times the pressure at which the pressure relieving device is set to function.

Each farm vehicle tank over 250 gallons and each storage container shall be provide with a pressure gage graduated from 0 to 400 psi. Gages shall be designated for use in ammonia service.

### **Credits**

#### HISTORY

1. Amendment filed 12-8-72 as procedural and organizational; effective upon filing (Register 72, No. 50).
2. Amendment of subsections (a), (b) and (f) filed 3-28-75; effective thirtieth day thereafter (Register 75, No. 13).

### **§509. Transfer of Liquids.**

---

(a) No anhydrous ammonia shall be vented to the atmosphere during the transfer operation unless the vent is led to a safe point of discharge.

Anhydrous ammonia shall not be stored in or transferred into a container at a temperature lower than that shown on the nameplate.

Containers shall be charged or used only upon authorization of the owner.

(b) No gas other than anhydrous ammonia vapor shall be used to displace anhydrous ammonia during the transfer operation.

(c) All filling connections and/or permanently installed transfer hoses shall be equipped with a shutoff valve at the discharge end and shall be kept effectively capped when not in use. These caps or plugs may be plastic or metallic, but must be so designed that they will be vented to the atmosphere while at least 3 full threads are engaged.

(d) During the transfer of anhydrous ammonia, at least 1 attendant familiar with the installation shall remain in attendance at the controls necessary to stop the transfer operation. This attendant shall be

considered familiar with the installation only after he has been provided with a set of operating instructions for the unloading operation and has been instructed through a minimum of 3 full cycles of operation. During the transfer of anhydrous ammonia into or from a transportation tank, the brakes of the transporting vehicle shall be set and the wheels blocked.

Provisions for unloading tank cars shall conform to the applicable recommendations contained in the DOT regulations. See 560 (e) for Railroad Tank Car Loading and Unloading.

(1) Caution signs shall be so placed on the track or car as to give necessary warning to persons approaching the car from open end or ends of siding and shall be left up until after the car is unloaded and disconnected from discharge connections. Signs shall be of metal or other suitable material, at least 12 by 15 inches in size and bear the words "STOP -- Tank Car Connected" or "STOP -- Men at Work" the word, "STOP", being in letters at least 4 inches high and the other words in letters at least 2 inches high. The letters shall be white on a blue background.

(2) The track of a tank car siding shall be substantially level.

(e) No anhydrous ammonia shall be transferred with the point of delivery less than 10 feet from any residential building, street, public highway, or sidewalk unless the failure to transfer would create a hazard.

(f) All pumps and compressors used for the transfer of anhydrous ammonia shall be suitable for this service and shall be equipped with a pressure-actuated bypass valve and/or other acceptable device to prevent pressure in the transfer equipment of more than 400 psi unless the piping system is specifically designed for higher pressures. In no case shall safety relief valves used for this purpose be set to open at pressures of less than 325 psi or more than 400 psi.

(1) Pumps shall be designed for at least 250 ~~p.s.i.~~ psi working pressure. Positive displacement pumps shall have, installed off the discharged port, a constant differential relief valve discharging into the suction port of the pump through a line of sufficient size to carry the full capacity of the pump at relief valve setting, which setting and installation shall be according to the pump manufacturer's recommendations.

On the discharge side of the pump, before the relief valve line, there shall be installed a pressure gage graduated from 0 to 400 ~~p.s.i.~~ psi.

Plant piping shall contain shutoff valves located as close as practical to pump connections.

(2) Compressors used for transferring or refrigerating ammonia shall be recommended for ammonia service by the manufacturer.

Compressors shall be designed for at least 250 ~~p.s.i.~~ psi working pressure.

Plant piping shall contain shutoff valves located as close as practical to compressor connections.

A relief valve large enough to discharge the full capacity of the compressor shall be connected to the discharge before any shutoff valve.



Compressors shall have pressure gages at suction and discharge graduated to at least one and one-half times the maximum pressure that can be developed.

Adequate means, such as drainable liquid trap, shall be provided on the compressor suction to minimize the entry of liquid into the compressor.

Where necessary to prevent contamination, an oil separator shall be provided on the discharge side of the compressor.

(g) The filling densities for containers that are not refrigerate shall not exceed the following:

<i>Type of Container</i>	<i>Percent By Weight</i>	<i>Percent By Volume</i>
Uninsulated	56	82
Uninsulated (see 509(h))		87.5
Insulated	57	83.5

D.O.T. In accordance with D.O.T. Regulations

(h) Uninsulated containers may be charged 87.5 percent by volume provided the temperature of the anhydrous ammonia being charged is determined to be not lower than 30° F. or provided the charging of the container is stopped at the first indication of frost or ice formation on its outside surface and is not resumed until such frost or ice has disappeared.

Any container, including DOT cargo and portable tanks, shipped under DOT jurisdiction shall be filled according to DOT regulation.

(i) Every portable unloading facility shall comply with the following additional requirements:

(1) A set of written instructions shall be posted at the location or supplied to the operating personnel, describing in detail the proper procedures to follow in operating the transfer equipment.

(2) A container of at least 5 gallons of fresh water shall be located at this facility. This container shall have a suitable opening to permit the application of water to flush the eyes. (A suitable deluge-type, freshwater shower may be installed in lieu of the above if connected to a reliable source of supply.)

(3) The point of delivery from portable transfer facilities shall be in compliance with the requirements for stationary tanks, as listed in Section 501 (c); except that such point of delivery may be less than 50 feet but not less than 25 feet, from a highway or main track of a railroad.

(4) The working area at the portable transfer facility shall be kept clear of debris, and all compressors, pumps, hoses, valves, etc., shall be protected from vehicle impact. Such equipment shall also be suitably locked or otherwise confined when unattended, to prevent the release of ammonia to the atmosphere by unauthorized persons.

(5) The portable unloading facility must be secured at the end of each period of operation; i.e., the point at which it becomes unattended, the end of a workday, etc.

The facility will be considered secured when all ammonia liquid is confined in the pressure vessel and the gas pressure in any hose is less than 25 psi.

(6) All pressure vessels, hoses, piping, fittings, etc., shall be as required elsewhere in these orders for anhydrous ammonia in the liquid state (high pressure).

NOTE: Portable transferring facilities for anhydrous ammonia is defined as any site at which anhydrous ammonia is transferred from one pressure vessel to another in which the compressor and receiving vessel are not permanently installed on concrete in accordance with Safety Section 501.

(j) Compressors, excepting those on farm vehicles, shall be equipped with manually operated shutoff valves on both suction and discharge connections. Pressure gages of bourdon-tube type shall be installed on the suction and discharge of the compressor before the shutoff valves. The compressor shall not be operated if either pressure gage is removed or is inoperative. A spring-loaded safety-relief valve capable of discharging to atmosphere the full flow of gas from the compressor discharge and the discharge shutoff valve.

(k) Valve functions shall be clearly and legibly identified by metal tags or nameplates permanently affixed to each valve.

## **Credits**

### HISTORY

1. Amendment filed 12-8-72 as procedural and organizational; effective upon filing (Register 72, No. 50).
2. Amendment filed 3-28-75; effective thirtieth day thereafter (Register 75, No. 13).
3. Amendment of subsection (d) filed 5-6-77; effective thirtieth day thereafter (Register 77, No. 19).

## **§510. Hose Specifications.**

---

(a) Hose and hose connections shall be fabricated of materials that are resistant to the action of anhydrous ammonia. Hose used in ammonia service shall conform to ANI-RMA (or TFI-RMA) Standard No. M-5 for anhydrous ammonia hose. (TFI-RMA stands for The Fertilizer Institute-Rubber Manufacturers Association.)

Metallic hose is a hose in which the strength depends primarily upon the strength of its metallic parts, but it may have nonmetallic liners and/or covers. The metal used in this hose shall be stainless steel or other suitable materials acceptable to the Division.

All hose and hose connections subjected to tank pressure shall be designed for a minimum working pressure of 350 psi with a factor of safety of at least 5.

After the hose connections are made up, they shall withstand without leakage a test pressure of twice the working pressure for which the hose is designed.

Hose and hose connections located on the low-pressure side of pressure-reducing valves or devices and discharging to atmospheric pressure shall be designed for a working pressure of at least 125 psi with a factor of safety of at least 5.

(b) All hose 1/2 inch in diameter and larger used for either liquid or vapor service shall be permanently and clearly marked at intervals of not more than 5 feet with the following information:

(1) The words "Anhydrous Ammonia" or "NH<sub>3</sub>"

(2) The designed working pressure

(3) The manufacturer's name or trademark

(4) The year of manufacture. ~~Hose smaller than 1/2 inch in diameter need only be marked with items (1) and (2) above.~~

Hose smaller than 1/2 inch in diameter need only be marked with items (1) and (2) above.

(c) All anhydrous ammonia hoses and hose connections subjected to tank pressure shall be tested at least once each year to twice the tank working pressure but not less than 500 psi. While in transit all hoses and hose connections shall be protected from wear or injury.

All low-pressure hose shall be constructed for ammonia service with a factor of safety of at least 5, but in no case shall hose be used for this service unless designed for a working pressure of at least 125 psi with a factor of safety of at least 5.

### **Credits**

#### HISTORY

1. Amendment filed 12-8-72 as procedural and organizational; effective upon filing (Register 72, No. 50).
2. Amendment of subsections (a) and (c) filed 3-28-75; effective thirtieth day thereafter (Register 75, No. 13).

### **§511. Safety Relief Valves.**

(a) Every vessel used in anhydrous ammonia service shall be fitted with 1 or more safety relief valves in direct communication with the vapor space. These safety relief valves shall be of the spring-loaded type suitable for anhydrous ammonia service. The discharge from safety relief valves shall be full size and be directed away from the vessel, and shall discharge upward and unobstructed to the open air.

All relief-valve discharge openings shall have suitable loose-fitting rain caps that will allow free discharge of the vapor and prevent entrance of water. Provision shall be made for draining condensate which may accumulate in the discharge pipe.

The safety relief valves for anhydrous ammonia service shall be set to start to discharge with relation to the allowable working pressure of the vessel as follows:

<i>Pressure vessels constructed in accordance with:</i>	<i>Minimum</i>	<i>Maximum</i>
Code paragraphs U-68 and U-69	110%	125%
Code paragraphs U-200, through 1974 edition	100%	<del>110%</del> 100%
API-ASME Code	100%	<del>110%</del> 100%
DOT Cylinders	As required by DOT Regulations	

(b) Except for code paragraphs U-68 and U-69 tanks, the discharge capacity of safety relief valves for anhydrous ammonia tanks shall be sufficient to prevent pressure in the tank from exceeding 120 percent of the allowable working pressure of the tank. ASME code paragraphs U-68 and U-69 tanks shall have safety valve capacity sufficient to prevent pressure in the tank from exceeding 135 percent of the allowable working pressure of the tank. All safety relief valves required by this Order shall be ASME rated and stamped. The minimum required rate of discharge of safety relief valves for anhydrous ammonia tanks shall be in accordance with the following table:

<i>Surface area</i>		<i>Flow rate</i>		<i>Surface area</i>		<i>Flow rate</i>		<i>Surface area</i>		<i>Flow rate</i>	
<i>sq. ft</i>	<i>CFM air</i>	<i>sq. ft</i>	<i>CFM air</i>	<i>sq. ft</i>	<i>CFM air</i>	<i>sq. ft</i>	<i>CFM air</i>	<i>sq. ft</i>	<i>CFM air</i>	<i>sq. ft</i>	<i>CFM air</i>
20 or less	.....258	185	.....1,600	900	.....	5,850					
25	.....310	190	.....1,640	950	.....	6,120					
30	.....360	195	.....1,670	1,000	.....	6,380					
35	.....408	200	.....1,710	1,050	.....	6,640					
40	.....455	210	.....1,780	1,100	.....	6,900					
45	.....501	220	.....1,850	1,150	.....	7,160					
50	.....547	230	.....1,920	1,200	.....	7,410					
55	.....591	240	.....1,980	1,250	.....	7,660					
60	.....635	250	.....2,050	1,300	.....	7,910					

65 .....678	260 .....2,120	1,350 ..... 8,160
70 .....720	270 .....2,180	1,400 ..... 8,410
75 .....762	280 .....2,250	1,450 ..... 8,650
80 .....804	290 .....2,320	1,500 ..... 8,900
85 .....845	300 .....2,380	1,550 ..... 9,140
90 .....885	310 .....2,450	1,600 ..... 9,380
95 .....925	320 .....2,510	1,650 ..... 9,620
100 .....965	330 .....2,570	1,700 ..... 9,860
105 .....1,010	340 .....2,640	1,750 ..... 10,090
110 .....1,050	350 .....2,700	1,800 ..... 10,330
115 .....1,090	360 .....2,760	1,850 ..... 10,560
120 .....1,120	370 .....2,830	1,900 ..... 10,800
125 .....1,160	380 .....2,890	1,950 ..... 11,030
130 .....1,200	390 .....2,950	2,000 ..... 11,260
135 .....1,240	400 .....3,010	2,050 ..... 11,490
140 .....1,280	450 .....3,320	2,100 ..... 11,720
145 .....1,310	500 .....3,620	2,150 ..... 11,950
150 .....1,350	550 .....3,910	2,200 ..... 12,180
155 .....1,390	600 .....4,200	2,250 ..... 12,400
160 .....1,420	650 .....4,480	2,300 ..... 12,630
165 .....1,460	700 .....4,760	2,350 ..... 12,850
170 .....1,500	750 .....5,040	2,400 ..... 13,080
175 .....1,530	800 .....5,300	2,450 ..... 13,300
180 .....1,570	850 .....5,590	2,500 ..... 13,520

Surface area = total outside surface area of container in square feet. When the surface area is not stamped on the nameplate or when the marking is not legible, the area can be calculated by using one of the following formulas:

(1) Cylindrical container with hemispherical heads.

Area = overall length in feet times outside diameter in feet times 3.1416

(2) Cylindrical containers with other than hemispherical heads.

Area = (overall length in feet plus 0.3 outside diameter in feet) time outside diameter in feet times 3.1416

(3) Spherical container.

Area = outside diameter in feet squared times 3.1416

Flow rate -- CFM Air = cubic feet per minute of air required at standard conditions, 60 degrees Fahrenheit and atmospheric pressure (14.7 psia).

The rate of discharge may be interpolated for intermediate values of surface area. For containers with total outside surface area greater than 2,500 square feet, the required flow rate can be calculated using the formula: Flow Rate CFM Air =  $22.11A^{0.82}$ , where A = outside surface area of the container in square feet.

The minimum required rate of discharge of safety relief valves for anhydrous ammonia DOT cylinders shall be in accordance with the regulations of the ~~Bureau of Explosives~~ DOT.

(c) Safety relief valves shall be so designed and installed that the possibility of tampering will be minimized. If the pressure setting is external, the relief valves shall be provided with acceptable means for sealing the adjustment.

(d) Shutoff valves shall not be installed between the safety relief valve and tank, except that a shutoff valve may be used where the arrangement of this valve is such as always to provide full required capacity flow through sufficient relief valves to properly protect the tank. [This exception is intended to permit 3-way valves, mechanically interconnected valves, etc., to be installed between the tank and safety valve where the installation and arrangement will always permit the required number of valves to be in communication with the tank to provide the relief capacity required by (b) above.]

The flow capacity of the relief valve shall not be restricted by any connection to it on either the upstream or downstream side.

(e) Each safety relief valve used on anhydrous ammonia tanks shall be plainly marked with the following information:

- (1) With the letters "AA".
- (2) The pressure in pounds per square inch gage (psig) at which the valve is set to start to discharge.
- (3) The rate of discharge of the valve at its full open position in cubic feet per minute (cfm) of air.
- (4) The manufacturer's name and catalog number.
- (5) The symbol of the ASME Code.

### **Credits**

#### HISTORY

1. Amendment filed 12-8-72 as procedural and organizational; effective upon filing (Register 72, No. 50).
2. Amendment of subsections (a) and (d) filed 3-28-75; effective thirtieth day thereafter (Register 75, No. 13).

### **§512. Repairs and Alterations.**

---

~~(a) Field welding, where necessary, shall be made only on nonpressure parts that were installed by the manufacturer of the tank.~~

~~(ab) No repairs or alterations involving flame, arc, or other method of welding shall be made to any tank until such tank has first been certified as free of anhydrous ammonia by competent personnel.~~

~~(c) No repair or alteration affecting the safety of the tank shall be made until the contemplated repair or alteration has been authorized by a qualified inspector. Nothing in this order shall prohibit the exchange or interchange of valves, fittings, and appurtenances intended for the same purpose.~~

~~(d) No tank that has been subjected to a fire shall be returned to service until it has been inspected by a qualified inspector and found to be safe.~~

~~(e) Any vessel requiring repair or alteration or that has been subjected to a fire shall be prepared for hydrostatic test by the owner when such test is deemed necessary by the qualified inspector.~~

~~(f) All repairs affecting the safety of the tank shall be reported to the Division within 21 days by the qualified inspector authorizing such repairs. The qualified inspector shall stamp his certificate of competency number adjacent to all welded repairs authorized by him, except that in the case of repairs to quenched and tempered steels, this number need not be stamped. This exception shall be noted on the inspector's report.~~

~~(g) Any welding necessary when making repairs or alterations to tanks shall be done by welders and welding procedures qualified in accordance with Section IX of the ASME Code in the position or positions used in making the repair.~~

### **Credits**

#### HISTORY

1. Amendment filed 12-8-72 as procedural and organizational; effective upon filing (Register 72, No. 50).

### **§513. Anhydrous Ammonia Refrigeration Systems.**

---

Mechanical refrigeration systems using anhydrous ammonia as a refrigerant shall be installed and maintained according to the provisions of the General Industry Safety Orders.

### **Credits**

#### HISTORY

1. Amendment filed 12-8-72 as procedural and organizational; effective upon filing (Register 72, No. 50).

### **§514. Installation of Refrigerated Storage Containers.**

---

(a) Containers shall be supported on suitable noncombustible foundations designed to accommodate the type of container being used.

Adequate protection against flotation or other water damage shall be provided wherever high flood water might occur.

Containers for product storage at less than 32° F. shall be supported in such a way, or heat shall be supplied, to prevent the effects of freezing and consequent frost heaving.

(b) A check valve shall be installed in lieu of the required excess flow valve on the fill connection, except when flow is needed in both directions, and a remotely operated shutoff valve shall be installed on all other connections located below the maximum liquid level.

(c) The filling density for refrigerated storage containers shall be such that the container will not be liquid full at a liquid temperature corresponding to the vapor pressure at the start-to-discharge pressure setting of the safety-relief valve.

(d) Safety-relief valves shall be set to start-to-discharge at a pressure not in excess of the design pressure of the container and shall have a total relieving capacity sufficient to prevent a maximum pressure in the container of more than 120 percent of the design pressure. Relief valves for refrigerated storage containers shall be self-contained spring-loaded, weight-loaded, or self-contained pilot-operated type.

The total relieving capacity shall be the larger of: ~~(1) Possible refrigeration system upset such as (A) cooling water failure, (B) power failure, (C) instrument air or instrument failure, (D) mechanical failure of any equipment, (E) excessive pumping rates.~~

(1) Possible refrigeration system upset such as (A) cooling water failure, (B) power failure, (C) instrument air or instrument failure, (D) mechanical failure of any equipment, (E) excessive pumping rates.

(2) Fire exposure determined in accordance with Compressed Gas Association (CGA) S-1, Part 3, Safety Relief Device Standards For Compressed Gas Storage Containers, 1959, except that "A" shall be the total exposed surface area in square feet up to 25-foot above grade or to the equator of the storage container if it is a sphere, whichever is greater. If the relieving capacity required for fire exposure is greater than that required by (1) of this subdivision, the additional capacity may be provided by weak roof-to-shell seams in containers operating at essentially atmospheric pressure and having an inherently weak roof-to-shell seam. The weak roof-to-shell seam is not to be considered as providing any of the capacity required in (1) of this subdivision.

If vent lines are installed to conduct the vapors from the relief valve, the back pressure under full relieving conditions shall not exceed 50 percent of the start-to-discharge pressure for pressure balanced valves or 10 percent of the start-to-discharge pressure for conventional valves. The vent lines shall be installed to prevent accumulation of liquid in the lines.

The valve or valve installation shall provide weather protection.



Atmospheric storage shall be provided with vacuum breakers. Ammonia gas, nitrogen, methane, or other inert gases can be used to provide a pad.

(e) Appurtenances shall be protected against tampering and physical damage.

(f) Containers of such size as to require field fabrication shall, when moved and reinstalled, be reconstructed and reinspected in complete accordance with the requirements under which they were constructed. The containers shall be subjected to a pressure retest and if rerating is necessary, rerating shall be in accordance with applicable requirements.

(g) Precaution shall be taken against damage from vehicles.

(h) The total refrigeration load shall be computed as the sum of the following:

(1) Load imposed by heat flow into the container caused by the temperature differential between design ambient temperature and storage temperature.

(2) Load imposed by heat flow into the container caused by maximum sun radiation.

(3) Maximum load imposed by filling the container with ammonia warmer than the design storage temperature.

More than one storage container may be handled by the same refrigeration system.

(i) A minimum of two compressors shall be provided, either of which shall be of sufficient size to handle the loads listed in Section 514(h)(1) and (2). Where more than two compressors are provided, minimum standby equipment equal to the largest normally operating equipment shall be installed. Filling compressors may be used as standby equipment for holding compressors.

Compressors shall be sized to operate with a suction pressure at least 10 percent below the minimum setting of the safety valve(s) on the storage container and shall withstand a suction pressure at least equal to 120 percent of the design pressure of the container.

(j) Each compressor shall have its individual driving unit.

An emergency source of power of sufficient capacity to handle the loads listed in Section 514(h)(1) and (2) shall be provided unless facilities are available to safely dispose of vented vapors while the refrigeration system is not operating.

(k) The refrigeration system shall be arranged with suitable controls to govern the compressor operation in accordance with the load as evidenced by the pressure in the container(s).

An emergency alarm system shall be installed to function in the event the pressure in the container(s) rises to the maximum allowable operating pressure.

An emergency alarm and shutoff shall be located in the condenser system to respond to excess discharge pressure caused by failure of the cooling medium.

All automatic controls shall be installed in a manner to preclude operation of alternate compressors unless the controls will function with the alternate compressors.

(l) An entrainment separator of suitable size and design pressure shall be installed in the compressor suction line of lubricated compression. The separator shall be equipped with a drain and gaging device.

An oil separator of suitable size shall be installed in the compressor discharge line. It shall be designed for at least 250 psi and shall be equipped with a gaging device and drain valve.

(m) The condenser system may be cooled by air or water or both. The condenser shall be designed for at least 250 psi. Provision shall be made for purging noncondensibles either manually or automatically.

(n) A receiver shall be provided with a liquid-level control to discharge the liquid ammonia to storage. The receiver shall be designed for at least 250 psi and be equipped with the necessary connections, safety valves, and gaging device.

(o) Refrigerated containers and pipelines which are insulated shall be covered with a material of suitable quality and thickness for the temperatures encountered. Insulation shall be suitably supported and protected against the weather. Weatherproofing shall be of a type which will not support flame propagation.

#### **Credits**

NOTE: Authority cited: Section 142.3; Labor Code.

#### **HISTORY**

1. New section filed 3-28-75; effective thirtieth day thereafter (R3egister 75, No. 13).

#### **§515. Systems Utilizing Portable DOT NH3 Containers.**

---

(a) Cylinders shall comply with DOT specifications and shall be maintained, filled, packaged, marked, labeled, and shipped to comply with 49 CFR Chapter 1 and Marking Portable Compressed Gas Containers to Identify the Material Contained, ANSI Z48.1-1954 (R1970).

(b) Cylinders shall be stored in an area free from ignitable debris and in such manner as to prevent external corrosion. Storage may be indoors or outdoors.

(c) Cylinders filled in accordance with DOT regulations will become liquid full at 145° F. Cylinders shall be protected from heat sources such as radiant flame and steam pipes. Heat shall not be applied directly to cylinders to raise the pressure.

(d) Cylinders shall be stored in such manner as to protect them from moving vehicles or external damage.

(e) Any cylinder which is designed to have a valve protection cap shall have the cap securely in place when the cylinder is not in service.

### **Credits**

NOTE: Authority cited: Section 142.3, Labor Code.

### **HISTORY**

1. New section filed 3-28-75; effective thirtieth day thereafter (Register 75, No. 13).

## ***Article 7. Compressed and Liquefied Natural Gas System***

---

For Appendix A, refer to the end of Subchapter 1.

The provisions of Article 7 apply to the storage, dispensing and use of natural gas as a motor fuel, ~~but do not apply to the storage or use of natural gas on public roads and highways~~ except in vehicles that are licensed to travel on highways, for which the standards of the California Highway Patrol apply.

### **§523. Design and Construction of Natural Gas Tanks.**

---

(a) General. All new natural gas tanks shall be constructed, inspected, and stamped in compliance with the Code, unless the design, material, and construction of the tank are accepted by the Division as equivalent to code.

(b) Compressed Natural Gas. In addition to the stamping required by the Code, the stamping on all new CNG tanks shall include the following:

(1) Volumetric capacity in standard cubic feet of natural gas when filled to the limits provided by these regulations.

(2) The words "For CNG."

(3) The head and shell thicknesses.

(c) Liquefied Natural Gas. The outer vessel of double wall cryogenic vessels shall be designed for the full range of pressure and/or vacuum to which it will be subjected and for adequate structural support of the inner tank and insulation under all imposed loadings. Equipment shall For Appendix A, refer to end of subchapter 1.

In addition to the stamping required by the Code, the stamping for all new LNG tanks shall include the following:

- (1) Net volumetric capacity in U. S. gallons.
- (2) The words "For LNG."
- (3) The head and shell thicknesses.
- (4) Minimum safety relief valve capacity in cfm air. ~~See 541 (c) (1) and (2).~~

### **Credits**

NOTE: Authority cited: Section 142.3, Labor Code. Reference: Section 142.3, Labor Code, and Chapter 855, Statutes of 1977.

### **HISTORY**

1. Repealer of Article 7 (Section T8-550) and new Article 7 (Sections 523-544) filed 12-8-72 as an emergency; effective upon filing. Certificate of Compliance included (Register 72, No. 50).
2. Amendment of subsection (c) filed 8-6-76; effective thirtieth day thereafter (Register 76, No. 32).
3. Amendment of subsection (a) filed 4-1-77; effective thirtieth day thereafter (Register 77, No. 14).
4. Amendment filed 1-17-80; effective thirtieth day thereafter (Register 80, No. 3).
5. Amendment of article 7 headnote filed 9-25-2002 as an emergency; operative 9-25-2002 (Register 2002, No. 39). A Certificate of Compliance must be transmitted to OAL by 1-23-2003 or emergency language will be repealed by operation of law on the following day.
6. Certificate of Compliance as to 9-25-2002 order transmitted to OAL 1-17-2003 and filed 2-24-2003 (Register 2003, No. 9).

### **§524. Design and Construction of Compressed Natural Gas Cylinders.**

---

All new natural gas cylinders shall be constructed for the service pressure specified in and meet other DOT regulations.

### **§525. Design and Construction of LNG Vaporizers. (Repealed)**

---

### **Credits**

## HISTORY

1. Amendment of subsection (a) filed 8-6-76; effective thirtieth day thereafter (Register 76, No. 32).
2. Change without regulatory effect repealing Section 525 (Register 88, No. 15).

### **§526. Repairs and Alterations to Tanks, Welded Piping and to Welded Vaporizers Having a Volumetric Capacity in Excess of 1 U.S. Gallon. (Repealed)**

---

~~(a) No repairs or alterations involving flame, arc or other method of welding shall be made on any tank, vaporizer or piping unless such tank, vaporizer or piping shall first have been certified as natural gas free or oxygen free by competent personnel.~~

~~(b) No repair or alteration to a natural gas tank or welded vaporizer which affects the safety of such natural gas tank or welded vaporizer shall be made inspector. The exchange or interchange of valves, fittings and accessories intended for the same purpose need not be considered a repair or alteration.~~

~~(c) No tank, vaporizer or piping system that has been subjected to possible damage by fire shall be returned to service until it has been inspected by a qualified inspector and found to be safe.~~

~~(d) Any vessel, vaporizer or piping requiring repair or alteration or that has been subjected to a fire shall be prepared for hydrostatic test by the owner when such test is deemed necessary by the qualified inspector.~~

~~(e) No repairs shall be performed on any natural gas fueled motor vehicle nor on a transport tank, trailer or skid tank, whether empty or loaded, until reasonable precaution has been taken to provide the required safety.~~

~~(f) All repairs to natural gas tanks or vaporizers affecting the safety of such tanks or vaporizers shall be reported to the Division within 21 days by the qualified inspector authorizing such repairs. The qualified inspector shall stamp his certificate of competency number adjacent to all welded repairs authorized by him except that in the case of repairs to quenched and tempered steels, this number need not be stamped. This exception shall be noted in the inspector's report.~~

~~(g) Any welding necessary when making repairs or alterations to tanks, vaporizers or piping shall be done according to welding procedures and by welders qualified in accordance with the rules of Section IX of the ASME Code in the position or positions used in making the repair.~~

~~(h) Repairs to DOT cylinders shall be made under DOT regulations and control.~~

### **§527. Control of Products in Tanks and Cylinders. (Repealed)**

---

(a) General. Natural gas contaminants such as hydrogen sulfide and water shall be so minimized as to prevent any adverse effects on storage and utilization equipment.

(b) Compressed Natural Gas.

No natural gas shall be delivered into any vessel or system covered by these Safety Orders unless odorized. The gas shall have a distinctive odor of sufficient intensity so that the presence of the gas may be detected down to the concentration in air of not over 20 percent of the lower explosive limit. Odorants in the concentrations used shall be:

(1) Harmless to humans.

(2) Non-toxic.

(3) Non-corrosive to steel, iron, brass or copper.

(4) Non-soluble in water to an extent greater than 2.5 parts by weight of odorant to 100 parts by weight of water.

(5) Be compatible with natural gas at the pressures and temperatures to be encountered in storage, transfer and service.

(c) Liquefied Natural Gas.

The delivery of LNG into any vessel or system covered by these Orders shall be subject to monitoring by a methane gas detection system, as follows:

(1) Each methane gas detection system required by this section shall provide a warning when an airborne methane gas concentration exceeding 20 percent of the lower explosive limit is detected. The warning shall be plainly audible and visible to those within the zone of potential exposure to fire or explosion of the vessel, system, or delivery operation.

(2) Where LNG is delivered into a vessel or system that is part of a motor vehicle, the methane gas detection system shall function continuously during the course of the delivery operation so that methane leaks resulting in an airborne concentration exceeding 20 percent of the lower explosive limit will be detected in the immediate vicinity of the operation.

(3) Where LNG is delivered to any other vessel or system covered by these Orders, the methane gas detection system shall function continuously during the course of the delivery operation so that methane gas leaks resulting in an airborne concentration exceeding 20 percent of the lower explosive limit will be detected in the immediate vicinity of the operation and the entire vessel or system into which the LNG is delivered. After delivery is completed, the methane gas detection system shall be operated continuously in the immediate vicinity of the entire vessel or system into which the LNG was delivered for as long as the vessel or system contains LNG.

(4) Nothing in this section is intended to supercede or alter the applicable requirements of 13 CCR Section 935.

## NOTE

Authority cited: Section 142.3, Labor Code. Reference: Section 142.3, Labor Code.

## HISTORY

1. Amendment of subsections (a) and (b), new subsections (c)-(c)(4) and new Note filed 9-25-2002 as an emergency; operative 9-25-2002 (Register 2002, No. 39). A Certificate of Compliance must be transmitted to OAL by 1-23-2003 or emergency language will be repealed by operation of law on the following day.

2. Certificate of Compliance as to 9-25-2002 order, including further amendment of subsections (b) and (c)(1)-(3), transmitted to OAL 1-17-2003 and filed 2-24-2003 (Register 2003, No. 9).

### **§528. Transfer, Operation and Maintenance. (Repealed)**

---

#### (a) General:

(1) No natural gas shall be vented to the atmosphere unless the vent is led to a safe point of discharge. Nothing in this Order shall prohibit the use of gaging devices which vent to the atmosphere through an opening not exceeding No. 54 drill size.

(2) No smoking or open flame shall be permitted within 10 feet of any vessel during the filling operation.

(3) All threaded filling connections shall be kept effectively capped when not in use. These caps or plugs shall be so designed that they will vent to the atmosphere while at least 3 full threads are engaged.

(4) No employer or employee shall charge natural gas into any tank or cylinder not specifically designed for the most severe pressure and temperature conditions to which the vessel may be subjected.

(5) During the transfer of natural gas at least one attendant familiar with the transfer operation shall be responsible for and be on the premises during the transfer operation. during the transfer of LNG the attendant shall remain in attendance at the controls necessary to stop the transfer operation. The attendant required by this Order may be considered familiar with the transfer operation and has performed the operation at least through 3 full cycles under supervision. When natural gas is being transferred to or from a motor vehicle, the engine shall be stopped unless the motor is used to operate a pump or compressor required to transfer the product. During such loading or unloading from transportation tanks, the hand or emergency brake of the vehicle shall be set and the wheels blocked. Transportation tanks shall be bonded during the transfer operation except that bonding is not required where the transfer systems are depressurized by bleeding before disconnecting, see Paragraph 537(a)(4), and providing also that closed connections are made before transfer begins.

(6) No natural gas shall be transferred with the point of delivery less than 10 feet from any important building or house trailer, or within 5 feet from a sidewalk or public highway, street or road unless the failure to transfer would create a hazard. At the discretion of the Division, the point of delivery may be

located a lesser distance from important buildings constructed of concrete or masonry materials. Nothing in this Order shall be so construed as to prohibit the following:

(A) The fueling of machinery or vehicles used in road construction or maintenance.

(B) The filling of motor fuel tanks or cylinders of not more than 30-gallon capacity.

(7) Pumps and compressors shall be suitable for use with the product to be handled for the full range of pressure and temperature to which they may be subjected. Positive displacement transfer pumps shall be equipped with a pressure actuated bypass valve and/or a recirculating system which shall limit the pressure to the maximum design pressure of the pump or piping system whichever is lower.

(8) Control devices shall be designed for the pressure, temperature and service expected and shall be so installed that icing conditions will not cause malfunction.

(9) The owner and/or user shall maintain all pressure vessels and their appurtenances, piping systems, vaporizers, controls and devices in a safe condition.

(10) A portable fire extinguisher having a rate of not less than 20BC shall be provided at the transfer operation area.

(b) Compressed Natural Gas.

(1) The pressure to which a CNG tank is charged shall not exceed the maximum allowable working pressure of the tank being filled at normal temperature. DOT cylinders shall be charged in accordance with DOT pressure and temperature regulations.

(c) Liquefied Natural Gas.

(1) To provide for the expansion of LNG with temperature, the tanks shall not be filled beyond the level specified by the tank manufacturer and in no case more than 90 percent.

(2) Tank fuel loading and unloading areas shall be substantially level.

#### **§529. Gauging Devices For Liquefied Natural Gas Tanks. (Repealed)**

---

(a) A permanent dip pipe shall be installed in all LNG tanks filled by volume and shall be of such length that it will indicate when the tank is filled to the level specified by the manufacturer and in no case more than 90 percent. This fixed dip pipe shall be permanently installed in the tank. Additional dip pipes may be used providing they are permanently marked to show the outage they indicate.

(b) In addition to the fixed dip pipe required in (a) above, each LNG tank 60-gallon capacity or more, filled by volume, and each motor fuel tank shall be equipped with a liquid level gage.



~~(c) Gauging devices that require bleeding of the product to the atmosphere shall be so designed that the maximum opening of the bleeder valve is No. 54 drill size.~~

~~(d) Gauging devices shall be designed for the most severe pressure and temperature conditions to which the device may be subjected with a factor of safety of not less than 4. Such gaging devices shall be labeled with the maximum permitted pressure by the manufacturer.~~

~~(e) Where the efficiency of the insulation of an insulated tank is dependent upon the vacuum in an annular space, an indicating device or other means shall be provided to warn of loss of vacuum.~~

### **§530. Approval of Devices. (Repealed)**

---

~~(a) All devices which are used in natural gas installations shall be of a type and construction suitable for their intended use. The Division may approve or accept devices or package units upon satisfactory evidence that they are designed and constructed for safe operation in natural gas service.~~

~~(b) Except for control and indicating devices that are also designed for natural gas and which have an orifice not larger than No. 54 drill size, natural gas shall not be used to operate any device or equipment designed to be operated with compressed air which exhausts to the atmosphere. Natural gas vapor shall not be released into the air except as permitted by these Orders.~~

~~(c) All natural gas devices not otherwise specifically provided for shall be constructed and installed to provide safety equivalent to that required for other parts of the system.~~

~~(d) All electrical wiring and electrical equipment used with natural gas storage or dispensing apparatus shall be in accordance with the Electrical Regulations administered by the Division.~~

~~NOTE: For the purpose of this Order 530 (d), the electrical equipment installed in out-of-doors installations for stationary storage or the transfer of natural gas shall be suitable for uses in a Class 1, Division 1, Group D hazardous location when installed within 10 feet in any direction of any connection used for the transfer of natural gas.~~

~~In order to comply with the "source of ignition" provisions of Order 531 (a) electrical switches, lamps, etc., located outside the above 10-foot area, but within the area specified in Order 531(a) shall be suitable for use in a Class 1, Division 2, Group D, hazardous location. All electrical motors within this area shall be suitable for use in out-of-doors locations and shall be either:~~

~~(1) Of the explosion proof type.~~

~~(2) Of a type having no contactors, commutators or sparking parts.~~

~~(3) Of a totally enclosed type.~~

### **§531. Location of Storage Tanks and Regulating Equipment. (Repealed)**

---

(a) General:

(1) Except as provided elsewhere in these Orders, tanks, cylinders and regulating equipment used with natural gas storage and/or dispensing installations shall be located outside of buildings. Each individual tank or cylinder used for storage or dispensing natural gas shall be located with respect to the nearest important building, or line or adjoining property which may be built upon, or source of ignition, in accordance with the following table:

<i>Capacity Per Storage Tank or Bank of Cylinders U.S. Gallons</i>	<i>Minimum Distance In Feet</i>	<i>Distance Between Above Ground Storage Tanks, Feet</i>
To 500	10	3
501 To 2,000	25	3
2,001 To 30,000	50	5
30,001 To 70,000	75	1/4 of Sum of Diameter of Adjacent Tanks with
70,001 To 90,000	100	a Minimum of 5 Feet

NOTE: At the discretion of the Division, tanks may be located a lesser distance from important buildings constructed of concrete or masonry materials.

(2) No stationary storage vessel shall be located less than 10 feet from the nearest street line or sidewalk, nor less than 50 feet from the nearest rail of any railroad main track.

The distance between underground tanks shall be not less than 12 inches.

(3) Except as permitted in Section 543, filling connections shall not be located less than 10 feet from any opening into or under a building closed on more than 3 sides for filling connections 1/2 inch pipe size or less than 15 feet for larger sized filling connections.

(4) Readily ignitable material shall not be permitted within 10 feet of any stationary vessel or vaporizer.

(5) Regulators which are vented to atmosphere shall be installed in such a manner that moisture cannot enter the vent and accumulate above the diaphragm. Where the regulator vent may be obstructed due to rain, snow or icing conditions, shields, hoods or other suitable devices shall be provided to guard against closing the vent opening.

~~(b) Compressed Natural Gas.~~

~~(1) Multiple cylinder units or groups stored in the vertical position shall be limited to a width of no more than 4 cylinders. Units or groups stored in the horizontal position shall be limited to a height of 6 and a width of 4 cylinders. When stacked horizontally, the units or groups shall be separated by not less than 3 feet.~~

~~(2) No cylinder filling platform shall be located less than 10 feet from any storage tank, or 25 feet from the nearest important building or line of adjoining property that may be built upon. At the discretion of the Division, cylinder filling platforms may be located a lesser distance from important buildings constructed of concrete or masonry materials.~~

~~(c) Liquefied Natural Gas.~~

~~(1) All aboveground LNG tanks larger than 2,000 gallons shall have diked impounding areas or equivalent in accordance with Pamphlet 59-A of the National Fire Protection Association.~~

**§532. Installation of Aboveground Storage Tanks. (Repealed)**

---

~~(a) General.~~

~~(1) Storage tanks installed aboveground shall be installed on firm masonry or concrete foundations. Aboveground horizontal tanks shall have no more than 2 points of support longitudinally. Where necessary, tanks shall be securely anchored to prevent floating.~~

~~(2) Metallic structural supports, when used, shall be encased in concrete or other material having a fire resistant rating of at least 2 hours when the distance between the lower surface of the tank and the top of the concrete or masonry foundations exceeds 18 inches. In the case of a vertical tank having no more than one opening in the support skirt, interior fire protection of the skirt may be omitted. (Tanks of not more than 575-gallon capacity installed in areas having an average snowfall exceeding 18 inches may, at the discretion of the Division, be exempt from the provisions of this paragraph.)~~

~~(3) Every tank shall be so supported as to prevent the concentration of excessive loads on the tank at the points of support. All foundations and fastenings shall be designed to provide reasonable safety under all imposed loads including wind, earthquake, vibrations, etc. All tanks over 1,200 gallons capacity shall be installed on foundations in such a manner as to permit expansion and contraction.~~

~~(4) The valves and other appurtenances on tanks at all bulk plants, if the plant is not otherwise fenced, shall be surrounded by a rugged steel fence or equivalent. Fences which are not of an open mesh type may be used providing they are acceptable to both the local fire department and the Division. The fence required by this Section shall be at least 6 feet in height. Any fence completely surrounding the tank shall be located a minimum distance of 3 feet from the tank. Other tanks shall also be surrounded by a rugged steel fence or equivalent, if in the opinion of the Division a fence is needed to prevent unauthorized tampering. All fenced areas shall be kept locked when unattended.~~

(5) Aboveground storage tanks shall be protected from impact from trucks, trailers and other vehicles, where such impact is likely or probable, by suitable curbs, fences or posts and railings. Such curbs or fences shall be arranged so that they will not hamper free ventilation around the tanks.

(6) All loading and unloading connections at bulk plants shall be secured to a concrete bulkhead or equivalent designed to withstand the load imposed by the strongest pipe, hose or flexible metal hose, and fittings to be used in the transfer operation without breaking, or 2,000 pounds whichever is greater unless other adequate protection is provided. This bulkhead shall not be located underneath the tank. The loading and unloading connections shall be firmly secured to this bulkhead and the line between the bulkhead and tank shall be installed in a manner to provide for expansion, contraction, jarring, vibration and settling. Such bulkhead shall be located no less than 25 feet from the nearest important building or line of property adjoining that may be built upon. When in the opinion of the Division such bulkhead is necessary for the safety of the place of employment, it shall be required at storage plants other than bulk plants mentioned above.

(7) The fill line on storage tanks shall be equipped with a back-flow check valve to prevent discharge of the natural gas from the receiving tank in case of line, hose or fittings rupture.

(8) A fire extinguisher conforming to the provisions of California Administrative Code, Title 19, Chapter 1, Subchapter 3, and having a rating of not less than 20B shall be available and ready for use during the time natural gas is being transferred. The extinguisher carried on a bulk delivery or transportation vehicle may be considered as meeting the requirements of this Order when transferring natural gas from or to such vehicle provided the extinguisher has the required rating listed above.

(b) Compressed Natural Gas.

(1) When the tank is installed directly on concrete or masonry foundations, a corrosion pad shall be provided at the points of contact with the foundation. These corrosion pads shall be at least 3/16 inch thick, and have a width at least equal to the width of the foundation at the point of contact with the tank, but in no case shall they be less than 8 times the shell thickness in width. When corrosion pads or pad-type steel supports are used, the pads shall have corners rounded to a radius of not less than 6 times the pad thickness, and shall be attached to the shell with a continuous seal weld. These pads shall be not less than 1/4 the circumference of the shell in length.

(2) Pressure vessels which are made of materials that are subject to corrosion by atmospheric conditions and which are not provided with an allowance for external corrosion by a suitable increase in the design thickness shall be protected by painting or other equivalent means necessary to check active corrosion.

(3) Cylinders used at dispensing stations shall be installed on firm concrete or masonry foundations and located in accordance with 531(a) and (b).

(c) Liquefied Natural Gas.

(1) Supports for LNG tanks shall be designed to withstand low temperature effects of LNG spillage.

(2) LNG tanks installed in battery shall be so installed that the 90 percent outage levels or the top surfaces of the tanks are substantially in the same horizontal plane.

~~(3) Tanks installed in battery shall not be installed with liquid and/or vapor lines connecting into common headers unless either:~~

~~(A) The working pressure of all such tanks is the same.~~

~~(B) Check valves or other devices are installed in the system to prohibit the introduction of the higher pressure product into the lower pressure tank.~~

**HISTORY:**

1. Amendment of subsection (b) filed 8-7-76; effective thirtieth day thereafter (Register 76, No. 32).

**§533. Location and Installation of Underground Tanks. (Repealed)**

---

~~(a) General. Tanks and regulating equipment shall not be buried below ground unless written permission to do so has been obtained from the Division and the following special conditions are complied with:~~

~~(1) The proposed location complies with Order 531(a)(1), (2) and (3).~~

~~(2) The tank shall be set with the top at least 24 inches below the surface of the ground, shall rest on firm foundations and shall not be installed under roadways.~~

~~(3) Before any back-filling is done, the installation shall be inspected by a qualified inspector and shall comply with all applicable sections of these Orders.~~

~~(4) The back-filling shall be done in such a manner that there will be at least 6 inches of water-washed sand free from soil, rocks or gravel immediately adjacent to the tank. The sand shall be well tamped into place during the back-filling operation.~~

~~(5) All buried tanks shall be constructed for underground services and the manufacturer shall provide means for lowering the tank into place without damage to the tank or corrosion-resistant coating.~~

~~(6) If the valves and fittings are located in a curb box, adequate provision shall be provided for proper drainage and ventilation of the curb box.~~

~~(7) No curb box shall be larger than necessary for the operation and maintenance of the valves and fittings located therein nor more than 3 feet in depth.~~

~~(8) All buried tanks shall be completely uncovered for an inspection of all external surfaces at intervals of at least once every 3 years.~~

The intervals may be changed at the discretion of the Division if a test plate is buried adjacent to the tank and shows no appreciable corrosion on inspection after 3 years of service; provided, however, that every tank shall be uncovered at least every 15 years. The test plates shall be of the same material as the shell of the tank and shall be at least 1/4 of the tank diameter in length and 6 inches wide and shall

be buried in water-washed sand at least as deep as the lowest surface of the tank, and shall not be coated. Test plates shall be provided in accordance with the following table:

(A) Tanks 10 feet or less in length, one test plate.

(B) Tanks more than 10 feet but less than 20 feet in length, 2 test plates, one on each side near opposite ends.

(C) Tanks 20 feet or more in length, one test plate for each 10 feet of length, placed on alternate sides at 10-foot intervals.

(9) No tank used underground shall be reinstalled aboveground until it has been inspected and found to be in compliance with requirements for an aboveground installation.

(10) Where necessary, tanks shall be securely anchored or weighted to prevent floating.

(b) Compressed Natural Gas. The exterior surfaces of CNG tanks shall be covered with an acceptable corrosion-resistant material.

Tanks will be considered acceptable when prepared and coated as follows:

(1) Clean and prime.

(2) Coat with asphalt enamel.

(3) Wrap with 40-pound felt.

(4) Coat with asphalt enamel.

(5) Wrap with 40-pound felt.

(6) Coat with asphalt enamel.

(7) Wrap with Kraft paper.

Equivalent corrosion protection may be accepted at the discretion of the Division.

(c) Liquefied Natural Gas.

(1) LNG vessels utilizing a vacuum jacket shall be so installed that a vacuum leak can be detected, and so piped that means can be provided to restore the vacuum or minimize the leak.

(2) Consideration shall be given to the design and installation of the supporting members and surrounding materials in the possible freezing zone to prevent damage to the tank and its supports by low temperature effects of LNG spillage or by frost heaving.

(3) LNG vessels having an outer jacket made of a material which may be subject to corrosion shall be protected in accordance with (b) above.

#### **§534. Skid Tanks. (Repealed)**

---

(a) Skid tanks shall be securely fastened to skids extending the full length of the tank, including fittings and guards at the end of the tank. The bottom of the skids shall be not less than 2 inches nor more than 12 inches below the outside bottom of the tank shell. The skids or lugs for attachment of the skids shall be secured to tanks in accordance with the Code or rules under which the tank is designed and built, and shall be designed to withstand the loaded weight of the tank in any direction with a factor of safety of at least 8.

(b) Fittings on skid tanks shall be installed in a recessed well or otherwise protected by means of adequate guards properly installed.

(c) Unless installed in compliance with Order 532, skid tanks shall not be used at any location for more than 180 days without written permission from the Division.

(d) When skid tanks are transported from one location to another, they shall be adequately secured to the transporting vehicle.

#### **§535. Installation of Tanks on Transportation and Bulk Delivery Vehicles. (Repealed)**

---

Transportation tanks shall comply with the regulations for such vehicles adopted by the Department of Highway Patrol.

#### **§536. Piping Standards. (Repealed)**

---

(a) General.

(1) All pipe, tubing, fittings and other piping components between the tank and the first shutoff valve shall be designed for the full range of pressures, temperatures and loadings to which they may be subjected with a factor of safety of at least 8 based on the minimum specified tensile strength at room temperature. All other pipe, tubing, fittings and other piping components shall be suitable for the full range of pressures, temperatures and loadings to which they may be subjected with a factor of safety of at least 4. In no case may underground piping be less than Schedule 80 for piping systems having a working pressure exceeding 100 psi. Any material used, including gaskets and packing, shall be compatible with natural gas and its service conditions.

(2) All piping and tubing shall be run as directly as practical with adequate provisions for expansion, contraction, jarring, vibration and settling. Exterior piping may be either buried or installed aboveground and shall be well supported and protected against mechanical damage.

Underground piping shall be buried not less than 18 inches below the surface of the ground unless otherwise protected. All underground piping shall be protected from corrosion by coating in compliance with Section 533(b) or equivalent. Zinc coatings (galvanizing shall not be considered adequate protection for piping below ground.

(3) All welded piping shall be fabricated and tested in accordance with the ANSI Code for Pressure Piping, Petroleum Refinery Piping, B31.3, 1966 Edition or equivalent.

(4) All valves shall be suitable for the full range of pressure and temperature to which they may be subjected. The manufacturer shall stamp or otherwise permanently mark the valve body to indicate the service ratings. Other piping components such as strainers, snubbers and expansion joints shall also be permanently marked by the manufacturer to indicate the service ratings. All materials such as valve seats, packing, gaskets, diaphragms, etc. shall be resistant to the action of natural gas under the conditions to which they are subjected.

(5) Use of the following is prohibited:

(A) Valves, cocks, fittings and other piping components of cast iron or semisteel other than ASTM Specifications A-536-67, Grade 60-40-18; A-395-68; A-47-68, Grade 35018 and A-445-66 unless they have pressure-temperature ratings at least equal to 1 1/2 times the design service conditions. In no case shall valves of cast iron or semisteel other than the 3 ASTM specifications listed above be used for primary stop valves.

(B) Street ells and screwed service tees.

(C) Valves of a design that will allow the valve stem to be removed without removal of complete valve bonnet or disassembly of the valve body.

(D) Plastic pipe, tubing, hose and fittings, without written permission from the Division.

(E) Valves with valve stem packing glands which cannot be repacked under pressure, unless there is another stop valve of acceptable type between them and the vessel. This does not apply to service valves.

(F) Aluminum tubing for exterior locations and threaded aluminum connections and adapters that are required to be connected or disconnected as part of the filling or transferring operation for those connections and adapters that are specifically designed with special threads suitable for this service.

(G) Pipe nipples in lieu of couplings or flanges in tank connections.

(H) Copper alloy with copper content exceeding 70 percent.



~~(b) Compressed Natural Gas. Hose shall not be used in lieu of manifolds, piping or tubing between dispensing tanks and cylinders and the connection for the loading and/or unloading hose connections, except that a section of metallic hose not to exceed 24 inches in length may be used in each pipeline to provide flexibility where necessary. Each section shall be so installed that it will be protected against mechanical damage and be readily visible for inspection. The manufacturer's identification shall be retained in each section.~~

~~(c) Liquefied Natural Gas.~~

~~(1) Flanged joints or threaded joints which have not been seal welded on liquid lines between the tank and the first shutoff valve are prohibited.~~

~~-~~

~~(2) All LNG piping over 2-inch pipe size shall be welded flanged or silver brazed with a material having a melting point exceeding 1,000 degrees Fahrenheit. Compression type couplings and threaded joints shall not be used except that seal welded threaded joints may be used.~~

~~(3) Piping 2-inch or smaller may be threaded, welded or flanged except as prohibited in 536(c)(1).~~

~~(4) Threaded nipples and pipe shall be at least Schedule 80.~~

~~(5) Plugs shall be solid or else they shall be bull plugs of at least Schedule 80 seamless pipe.~~

~~(6) For service temperatures of minus 20 degrees Fahrenheit or above, threaded piping and tubing with compression type couplings may be used except as prohibited in 536(c)(2).~~

~~(7) Pipe supports for piping having a service temperature below minus 20 degrees Fahrenheit shall be designed to minimize heat transfer so that support steel embrittlement~~

~~and piping restraints caused by ice formation will be prevented.~~

~~(8) Bellows type expansion joints in low temperature service shall be provided with external insulation that will prevent ice from forming on the bellows.~~

**HISTORY:**

1. Amendment of subsections (a)(1) and (a)(5)(F) filed 3-29-74; effective thirtieth day thereafter (Register 74, No. 13).

**§537. Piping Systems Valving and Labeling. (Repealed)**

---

~~(a) General.~~

(1) All piping and tubing shall be tested after assembly and proved free from leaks at a pressure equal to the maximum working pressure of that portion of the system or its safety valve setting, whichever is greater, except for welded piping [see 536(a)(3)].

(2) Where excess flow valves are used, the closing flow shall be less than the flow rating of the piping system between the excess flow valve and the equipment downstream of the excess flow valve.

(3) When two or more vessels, other than motor fuel tanks or cylinders, are manifolded together or when branches or restrictions are incorporated into the piping system, additional excess flow valves or equivalent shall be installed where the flow rating of the piping is less than the closing flow rating of the excess flow valves in the vessels. The additional excess flow valves or equivalent shall be located as close to the point of branching or restriction as possible.

NOTE: A quick-closing manually operated valve may be considered equivalent to an excess flow valve at the point of pipe size reduction or other restriction providing:

(1) It is equipped with a means for closing the valve manually from a point remote from the delivery connection.

(2) The loading and/or unloading line in which it is located is secured to a bulkhead complying with Section 532(a)(6).

(3) The quick-closing valve is in the pipeline on the tank side of the bulkhead.

(4) Bleed connections shall be provided in transfer systems to permit depressurizing the line before disconnecting. These bleed connections shall discharge at a safe place.

(5) Piping, compressors, pumps, valves, regulators, gaging and other vessel accessory equipment shall be protected against physical damage, including vehicular.

(b) Compressed Natural Gas.

(1) Except for safety relief valves and gaging connections all vessel connections, other than in motor fuel tanks or cylinders, larger than 1/4 inch pipe size shall have one of the following installed directly in each connection:

(A) A back-flow check valve to prevent flow from the tank.

(B) An excess flow valve.

(2) A manually operated shut-off valve shall be installed as close to the vessel as practicable. Manually operated shut-off valves for DOT cylinders shall be provided in accordance with DOT regulations.

(3) Piping systems shall be protected against overpressure by safety relief devices. Relief devices installed to protect the piping system shall have sufficient capacity and shall be set to open at a pressure not exceeding 110 percent of the maximum allowable working pressure of the system or the pressure which produces a hoop stress of 75 percent of the specified minimum yield strength, whichever is lower.

(c) Liquefied Natural Gas.

(1) Except for safety relief valves and gaging connections all vessel connections, other than in motor fuel tanks, larger than 1/2-inch pipe size shall have one of the following installed directly in each connection (for the purpose of this Section tank connection location for double wall cryogenic vessels may be the point of penetration through the outer vessel or its jacketed extension):

(A) A back flow check valve to prevent flow from the tank.

(B) A manually operated internal valve equipped with a means for closing the valve from a point remote from the delivery connection. The closing mechanism or its control shall be fitted with a fusible link having a melting point of 200 degrees Fahrenheit to 250 degrees Fahrenheit which will cause the valve to close automatically in case of fire.

(C) Either an internal valve which can be operated manually and will close on excess-flow conditions or one which is normally closed and is opened by pump discharge pressure. These valves shall be equipped with a means for closing from a point remote from the delivery connection and the closing mechanism shall be fitted with a fusible section as required in (B) above.

(D) An excess flow valve. In addition, there shall also be a quick closing automatic valve located as close to the tank as possible and which shall remain closed except during transfer. This valve shall be equipped with a means for closing automatically from a point remote from the delivery connection and shall be fitted with a fusible section having a melting point of 200 degrees Fahrenheit to 250 degrees Fahrenheit which will cause the valve to close in case of fire. Piping and valves shall be of austenitic stainless steel as listed in ANSI Code For Pressure Piping, B 31.3, 1966 Edition, Table 302.2.1A. Piping between the tank and the valve inlet shall be seamless and at least Schedule 40. All joints in the piping to and including the valve inlet shall be welded in accordance with 536(a)(3).

(2) (A) Systems installed in accordance with (A) or (B) above shall have a manually operated shut-off valve located as close to the tank as practicable. Systems installed in accordance with (D) above shall have a manually operated shut-off valve located between the quick-closing automatic valve and the vessel.

(B) Systems with tank connections installed in accordance with (C) above shall have a manually operated shut-off valve located in the loading and/or unloading pipelines between the tank and the pump, meter or bulkhead whichever is nearest the tank.

(3) Wherever liquid can be trapped between two or more valves, a safety relief valve shall be installed to prevent excessive hydrostatic pressure. This safety relief valve shall start to discharge at not less than 125 percent nor more than 150 percent of the safe working pressure of the piping system between the two shut-off valves.

(4) All LNG tank connections having manually operated shut-off valves shall be labeled to indicate whether they communicate with the vapor or liquid space. At least one of the following methods shall be employed in labeling these connections:

(A) Tags of metal or other suitable material labeled "Liquid" or "Vapor". These tags shall be fastened securely to the tank, to the primary manual valve or to the piping system at the valve. The legibility of these tags shall be maintained.

(B) Complete color painting of all visible parts of the piping or its insulation.

(C) Color bands not less than 4 inches wide at each tank connection or primary manual valve. These bands shall be readily visible on the insulation. Where identification is provided by complete color painting or by color bands, a color code shall be posted where visible from the transfer operation.

#### HISTORY:

1. Amendment of subsection (c)(4) filed 8-6-76; effective thirtieth day thereafter (Register 76, No. 32).

#### **§538. Hose, Metallic Hose, Flexible Metal Hose and Tubing Specifications. (Repealed)**

---

(a) Hose and metallic hose shall be of or lined with materials that are resistant to corrosion and to the actions of natural gas.

(b) Hose, metallic hose, flexible metal hose and tubing shall be suitable for the most severe pressure and temperature service conditions expected with a burst pressure of at least 4 times the maximum working pressure. Flexible metal hose or pipe with swivel joints shall be used for transfer operations where operating temperatures during transfer will be less than minus 20 degrees Fahrenheit.

(c) Connections for hose, metallic hose, flexible metal hose and tubing shall be designed with a burst pressure of at least 4 times the most severe pressure and temperature conditions expected.

(d) The components of the hose and metallic hose shall be tested after assembly and prior to use to at least 2 times the service pressure, and also tested to a pneumatic pressure of at least 600 psi under water. After the original installation, all hoses shall be examined visually at such intervals as are necessary to assure that they are safe for use. In no case shall such examination interval exceed one year. Hose shall be tested for leaks with soap suds or equivalent at least annually and any leakage shall be reason for rejection. This test shall be recorded and the record shall be available to the qualified inspector.

(e) All hose, metallic hose, flexible metal hose and tubing and their connections shall be maintained in a safe condition.

(f) While in transit, all hose and flexible metal hose and tubing to be used in the transfer operation, including their connections, shall be protected from wear or injury and shall be capped.

(g) Hose, metallic hose, flexible metal hose and tubing shall be distinctly marked either by the manufacturer's permanently attached tag or by distinct markings every 5 feet indicating the manufacturer's name or trademark, service and working pressure.

HISTORY:

1. Repealer and new subsection (g) filed 8-6-76; effective thirtieth day thereafter (Register 76, No. 32).

**§539. Pressure Gages. (Repealed)**

---

Every bulk storage tank, dispensing tank, transportation tank and bulk delivery tank shall be provided with a suitable pressure gage. The pressure gage shall be installed in a special gage outlet installed permanently on the tank or tank system and having an opening not to exceed No. 54 drill size opening at the tank connection. Pressure gages for LNG vessels shall have their connection above the maximum permissible liquid level. The pressure gage shall have a dial graduated to read approximately double the operating pressure, but in no case less than 1.2 times the pressure at which the pressure relief valve is set to function.

**§540. LNG Vaporizer Installation. (Repealed)**

---

(a) Vaporizers in excess of 1-gallon capacity shall be provided with suitable automatic means to prevent liquid from passing into the vapor system. This is not applicable to vaporizers discharging back to the vessel only.

(b) Vaporizers in excess of 1-gallon capacity shall be provided with one or more safety relief valves suitable for use with natural gas and set to open at not less than the maximum working pressure and not more than 110 percent of the maximum working pressure of the vaporizer.

(c) The minimum relieving capacity of the safety relief valves shall be at least equal to the capacity marking on the vaporizer nameplate as required in Section 525 (c)(5). This marking shall be determined for exposure to external fire and shall be sufficient to prevent pressure in the vaporizer from exceeding 120 percent of the maximum working pressure. When determined by calculation, the applicable formula in Appendix A shall be used.

The safety relief valve discharge shall be led outside of the vaporizer building, if any, and be discharged at a safe place.

(d) No coil or other device carrying artificial heat for vaporization shall be located inside of any LNG vessel not constructed for vaporizing only.

(e) Vaporizers shall not be installed inside of buildings unless the building is specifically designed for housing LNG vaporizers; in which case the building shall be constructed of non-combustible material and be adequately ventilated at both the floor line and ceiling. Ventilation shall be designed to prevent gasses lighter than air from being trapped at ceiling level.

NOTE: Ventilation is considered adequate when no mixture of flammable gases is permitted in concentrations exceeding 1/5 of the lower flammability limit for such mixture.

(f) Surge tanks, containing vapor only at 20 psi or less, shall be located at least 10 feet from important buildings and property lines. Such tanks operating at pressures exceeding 20 psi shall be located with respect to important buildings and property lines in accordance with Order 531(a).

**§541. Safety Relief Devices. (Repealed)**

---

(a) General.

(1) Unless covered elsewhere in these Orders, every natural gas tank shall be provided with one or more spring-loaded safety relief valves set to open as follows with relation to the maximum allowable working pressure:

<i>Type of Vessel</i>	<i>Minimum Safety Relief Valve Setting</i>	<i>Maximum Safety Relief Valve Setting</i>
ASME Code Constructed Vessels with a factor of safety of 5 or more	100%	125%
ASME Code Constructed Vessels built with a factor of safety of less than 5	100%	110%
DOT Cylinders— Safety Relief Devices	As approved by Bureau of Explosives	

All safety relief valves required by this Order shall be ASME labeled except for safety relief devices on DOT cylinders and safety relief valves as required in 537(c)(3), which may be ASME or Underwriters' Laboratories rated and stamped.

(2) Each safety relief valve shall be plainly marked by the manufacturer of the valve with the pressure in pounds per square inch at which the valve is set to start to discharge and the discharge capacity in cubic feet per minute (cfm) air.

(3) No shutoff valves shall be installed between the safety relief valves and the tank without written permission from the Division except that a shutoff valve may be used on multiple valve installations where the arrangement of the valves will provide full required flow through the safety relief valves at all times. The opening or connection between the tank and safety relief valve or valves shall have at least the combined areas of all connected safety relief valve inlets.

(4) Safety relief valves shall be so arranged that they will have an unobstructed full size discharge to a safe place, and shall be so arranged that escaping gas will not impinge on the vessel, valves or fittings.

(5) Except for safety valves that are integral with service valves, safety relief valves on tanks and cylinders shall be installed in a vertical position and shall be fitted with suitable raincaps.

(6) Safety relief valves for natural gas service shall not be fitted with lifting devices. The adjustment if external shall be provided with means for sealing the adjustment to prevent tampering by unauthorized persons. If at any time it is necessary to break such seal, the valve shall be removed from service until it has been reset and sealed. Any adjustments necessary to natural gas safety relief valves shall be made by the manufacturer or other companies having competent personnel and adequate facilities for the repair, adjustment and testing of such valves. The organization making such adjustment shall attach a permanent tag with the setting, capacity and date. All safety relief devices shall be tested at least annually and maintained in proper operating condition.

(7) If pressure regulators are used, a safety relief device shall be provided on the low pressure side of each final stage regulator and on the low pressure side of all other regulators unless the piping and/or fittings from the low pressure side of such regulators to the high pressure side of the next stage regulation are suitable for full tank pressure.

(8) Safety relief valves for surge tanks containing vapor only shall have a relieving capacity of not less than the maximum input from the system, vaporizer or reducing valves.

(9) Fusible plugs and/or rupture discs are prohibited for primary relief devices except as permitted in (b)(3) below.

(10) On underground installations, the discharge from safety relief valves shall be vertically upward and shall be piped to a point at least 10 feet aboveground, and shall meet the requirements for the location of tanks as specified in Order 531(a)(1), (2) and (3).

(b) Compressed Natural Gas.

(1) The minimum required rate of discharge of the safety relief valves for aboveground CNG tanks shall be at least equal to any input from the system, whether stored or being compressed.

(2) Safety relief valves located on stationary tanks of over 166,000 cubic feet capacity, shall be fitted with ferrous standpipes which will discharge at least 2 feet above the top of the tank, but not less than 10 feet above ground level. These standpipes shall not be threaded at the open end, and shall be fitted with suitable drain openings. Return bends and pipe fittings at the upper ends of safety relief valve discharge pipes are prohibited. Standpipes shall be adequately braced or otherwise supported if over 4 feet in length.

(3) Safety relief devices for DOT cylinders shall be provided in accordance with DOT regulations.

(4) Safety relief valves for underground CNG tanks shall have a relieving capacity of not less than that required for aboveground tanks.

(c) Liquefied Natural Gas.

(1) The minimum relieving capacity of the safety relief valves for LNG tanks shall be at least equal to the capacity marking on the vessel nameplate required in 523(c)(4).

(2) Safety relief capacity shall be determined for exposure to external fire and shall be sufficient to prevent pressure in the tank from exceeding 120 percent of the allowable working pressure for tanks built with a factor of safety of less than 5 and 150 percent for tanks built with a factor of safety of 5 or more. For calculating, the applicable formula in Appendix A shall be used to determine minimum relieving capacity.

(3) Safety relief valves for underground LNG tanks shall have a relieving capacity at least equal to the relief valve capacity markings on the vessel nameplate. When the capacity is not based on exposure of the vessel to fire, such underground tanks shall not be uncovered until they are free of liquid.

(4) Unless otherwise provided for in these Orders, safety relief valves shall have direct communication with the vapor space of the vessel.

(5) Safety relief valves located on stationary tanks over 2,000 gallons capacity shall be fitted with ferrous or suitable copper alloy standpipes which will discharge at least 2 feet above the top of the tank but not less than 10 feet above ground level. These standpipes shall not be threaded at the open end, and shall be fitted with suitable raincaps and shall be provided with a drain opening at their lower end unless the safety relief valves discharging into the standpipes are fitted with suitable drain openings. Return bends and pipe fittings at the upper ends of safety relief valve discharge pipes shall be prohibited. Standpipes shall be adequately braced or otherwise supported if over 4 feet in length.

(6) The outer tank of LNG vessels shall be provided with one or more relief devices set to open at not more than the maximum design working pressure of the outer tank. The discharge area shall be not less than .00024 square inch per pound of water capacity of the inner tank.

#### **§542. Warning Signs. (Repealed)**

---

(a) All tanks and cylinders in excess of 60 gallons capacity, except transportation tanks and fuel tanks on motor vehicles, shall have the word "FLAMMABLE" painted or otherwise suitably applied on each side that is readily visible. The letters of this sign shall be standard type and shall have a height of at least 1/12 of the diameter of the tank, but need not be in excess of 1 1/2 inches for tanks of 575 gallons capacity or less, or 4 inches for tanks exceeding 575 gallons capacity.

Transportation tanks shall have warning signs as required by the Department of Highway Patrol.

(b) Warning signs with the words "NO SMOKING OR OPEN FLAMES PERMITTED WITHIN \_\_\_\_ FEET" shall be painted or otherwise suitably applied in letters at least 1 1/2 inches high, in sharply contrasting colors on each stationary tank or on a sign posted adjacent to the tank. This sign shall also be posted adjacent to all loading and unloading terminals and vaporizers located more than 50 feet from the tank.

NOTE: The distance shall be that shown in the following table:



*Volumetric Capacity of Tanks and Cylinders in U.S. Gallons*    *Minimum Distance From Open Flame*

60 to 575 U.S. gallons inclusive	10 feet
576 to 2,000 U.S. gallons inclusive	25 feet
Over 2,000 U.S. gallons	50 feet

~~(c) When 2 or more tanks are installed in battery, the requirements of Order 542(a) and (b) will be considered as being complied with when the required warning signs are prominently displayed on all exposed sides of tanks.~~

**§543. Storage, Transfer and/or Vaporization of Natural Gas Within Buildings For the Purpose of Filling Motor Fuel Tanks or For Operating Stationary Internal Combustion Engines. (Repealed)**

---

~~(a) CNG may be stored and LNG may be stored or vaporized within a building or an enclosure providing that the structure is of non-combustible construction, that it is used for industrial purposes only and that the floor area does not exceed 500 square feet.~~

~~(b) The space shall be used exclusively for the vaporization of the CNG or LNG or for the storage of not more than a total of 41,500 standard cubic feet of CNG or 500 gallons of LNG. If vapors heavier than air can be present, the structure shall not be below ground level and the space below the floor shall either be of solid fill or else properly ventilated to the open air.~~

~~(c) In all cases ventilation must be provided at both floor and ceiling levels and shall be considered adequate when no mixture of flammable gases is permitted in concentrations exceeding 20 percent of the lower flammability limit for the mixture. The requirements of this paragraph may be met by either:~~

~~(1) A continuously operating mechanical ventilation system.~~

~~(2) A gravity ventilation system composed of a combination of wall vents at the floor level and roof ventilators, or~~

~~(3) A combination of the two.~~

~~(d) Pumps and compressors should be located outdoors in a freely ventilated area. If installed within a building, such building shall be open on at least one side or be of louvered construction on at least two sides unless other acceptable ventilation is provided and it shall also be equipped with adequate roof ventilators.~~

~~(e) All electrical wiring and electrical equipment shall be suitable for use in Class 1, Division 1 location if natural gas is transferred within a building or enclosure. All other electrical wiring and electrical~~

equipment located within a building where there is no transfer shall be suitable for use in a Class 1, Division 2, hazardous location.

~~(f) All gas piping to the building shall be provided with shutoff valves located outside the building. (Title 24, T8-543)~~

**HISTORY:**

1. Amendment filed 4-1-77; effective thirtieth day thereafter (Register 77, No. 14).

**§544. Installation of Fuel Tanks or Cylinders For Motor Vehicles and Industrial Trucks. (Repealed)**

---

NOTE: This Section does not apply to those vehicles under the control of the Department of Highway Patrol, except subsections (p), (q), and (r).

~~(a) Motor fuel tanks or cylinders shall be located in a place and in a manner to minimize the possibility of physical damage.~~

~~(b) Motor fuel tanks or cylinders for passenger type vehicles may be located in the trunk compartment provided the trunk compartment is properly ventilated and the safety relief valve discharge is piped outside. When a motor fuel tank or cylinder is installed inside a trunk or other compartment, positive means shall be provided to prevent leakage of natural gas into the passenger or driver's compartment. Vehicle tanks or cylinders that have their connections or appurtenances in the end shall have as much space as possible for connecting the required flexible metal hose or tubing and for operating the manually operated shutoff valve.~~

~~(c) If radio transmitting or receiving equipment is located in the same compartment as the fuel tank or cylinder, such transmitting or receiving equipment shall be enclosed in a vapor-tight compartment or otherwise protected from escaping fuel, unless the radio equipment is approved for use in a Class 1, Division 1, Group D location.~~

~~(d) For passenger-carrying or other commercial vehicles, motor fuel tanks or cylinders and their valves and appurtenances may be installed in a recess which is vapor-tight to the inside of the vehicle and accessible from and vented to the outside.~~

~~(e) Valves, fittings and appurtenances containing natural gas shall not be located in the passenger or driver compartment unless all such valves, fittings and appurtenances are positively sealed off from and vented to a point outside the passenger or driver compartment.~~

~~(f) Each motor fuel tank shall be provided with a manually operated shutoff valve screwed directly into the tank connection. The manual shutoff valve shall be readily accessible or an electrically operated valve shall be installed in the line next to the manual valve. The manual shutoff valve shall be legibly labeled "Shutoff Valve". In installations of multiple cylinder manifolding, there shall also be a master shut-off valve either electrically or manually operated and located downstream from but as close as~~

possible to the last cylinder in the series. In these cases there shall be a label indicating "Shut-off Valve" at the master valve and the individual tank valves need not be labeled.

(g) Motor fuel tanks or cylinders shall be installed in such a manner that the bottom of the vessel and/or any connection thereto shall not be lower than the lowest horizontal axle when the vehicle is fully loaded.

(h) Vents from control devices shall discharge outside the trunk compartment or other confined space.

(i) Motor fuel tanks or cylinders shall be secured in a manner to prevent jarring loose, slipping or rotating of the tanks. Such fastening shall be designed to withstand loadings in any direction equal to the filled weight of the tank with a factor of safety of at least 8. Motor fuel tanks or cylinders shall not be fastened directly to the gasoline fuel tank. Compensation shall be made for the added weight by proper design or redesign of the vehicle suspension system when the loaded weight of the vehicle exceeds the manufacturer's maximum specifications.

(j) Manifolder motor fuel tanks or cylinders shall be supported and held together as a unit by structurally adequate means. Manifolder branch lines shall be sufficiently flexible to prevent damage to the lines, valves and tanks due to vibration, expansion or contraction. Valves and appurtenances shall be protected from mechanical damage either by being located in recessed wells or by adequate guarding.

(k) All connecting parts of the fuel system shall be installed in such a manner as to prevent abrasion, vibration or fatigue and physical damage.

(l) Field welding, where necessary, shall be made only on saddle plates, brackets or other non-pressure parts that were provided and installed by the manufacturer of the tank or cylinder. There shall be no welding on the vessel shell or heads other than that by the manufacturer unless the welding is acceptable to the authorized inspector.

(m) The connection between the motor fuel tanks or cylinders and the reducing valves, vaporizer or other devices used to reduce the pressure to that needed for carburetion shall be of flexible metallic tubing, wire braided hose or equivalent with a factor of safety of not less than 5 for the most severe pressure and temperature design conditions. There shall be as few connections and fittings as practicable.

(n) Automatic pressure reducing equipment shall be used for the purpose of reducing the pressure of natural gas to the carburetor, which shall not exceed 5 psi. Positive means shall be provided to prevent malfunction due to refrigeration effects. There shall be a device in the fuel supply system which will automatically stop the flow of fuel when the engine is not running.

(o) Each driver shall be trained in the safe use of this fuel system and be provided with a set of operating instructions. The driver's employer shall be responsible to see that this is done.

(p) While the natural gas motor fuel tank or cylinder is being filled, the vehicle parking or emergency brakes shall be set and the motor shut off. All transfer operations shall be supervised by an attendant familiar with the transfer operation. The attendant may be considered familiar with the transfer operation after he has been provided with a set of instructions and has performed the transfer

operation at least through 3 full cycles under supervision. Where LNG motor fuel tanks or cylinders are being filled, the attendant shall remain at the controls necessary to stop the transfer operation.

~~(g) Fill connections for motor fuel tanks or cylinders shall have at least one back-flow check valve or device. Quick disconnect couplings may be used provided they are designed for the most severe pressure and temperature conditions with a factor of safety of at least 5 and provided they are leak-tight in the connected and disconnected shutoff conditions. These couplings shall not be used in lieu of any required manually operated shutoff valves.~~

~~(r) When motor vehicles are to be parked within buildings, adequate provisions shall be made such as roof ventilation to prevent gases lighter than air from being trapped at ceiling level. No source of ignition, electrical or otherwise, shall be permitted at those levels. (Title 24, T8-544(r)).~~

#### HISTORY:

~~1. Amendment filed 4-1-77; effective thirtieth day thereafter (Register 77, No. 14).~~

### **Article 10. Safe Practices**

#### **§560. Safe Practices.**

---

(a) No person shall do any of the following:

(1) Remove, displace, damage, destroy, or carry off any safety device, safeguard, notice, or warning for use in any employment or place of employment, or interfere in any way with their use by any other person (this is not intended to prohibit the removal for repair or maintenance of any safety device provided such device or a suitable replacement is reinstalled before the unit is replaced in service).

(2) Interfere with the use of any method or process adopted for the protection of any employee, including himself, in such employment or places of employment.

(3) Fail or neglect to do every other thing reasonably necessary to protect the life and safety of employees.

(b) The following Safety Orders from California Administrative Code, Title 8, are hereby made a part of these orders.

(1) General Industry Safety Order 3301: Use of Compressed Air or Gases. See Appendix B.

(2) General Industry Safety Order 3304: Miscellaneous Use of Compressed Cylinder Gas. See Appendix B.

(3) General Industry Safety Order 3312: Entering Combustion Chambers, Flues, Boilers or Unfired Steam Pressure Vessels. See Appendix B.

(4) General Industry Safety Order 3518: Air Compressors. See Appendix B.

(c) Compressed gases shall not be used to elevate or otherwise transfer any substance from or to a container unless the container(s) is/are designed to withstand the maximum possible pressure that may be applied with a factor of safety of at least 4.

Compressed gases shall not be used for pressure testing of any object until a safe pressure and procedure have been established.

Except where pressure tested in accordance with (d), elastic materials must not be gas tested at pressures above 67% of the minimum specified yield point at test temperature. Brittle materials must not be gas tested above 40% of the minimum specified ultimate strength without remote operation and missile shielding. "Brittle Material" is defined for this section as having a minimum specified elongation of 4% or less.

(d) Hydrostatic or Pneumatic Testing (subchapters 1 and 2) of Pressure Vessels, and included piping over 2" diameter.

(1) The rules of applicable Codes or Standards shall be used for hydrostatic, pneumatic or combination hydrostatic-pneumatic testing. Proof tests and tests to failure must also use procedures allowed by applicable codes or standards. If no applicable code or standard exists, the test procedure must be reviewed and accepted by the Division.

(2) All valves, fittings and flanges used for pressure testing equipment, for either new construction or repair, shall have a minimum pressure rating equal to the test pressure. Use of an applicable ANSI standard pressure-temperature table such as in ANSI B16.5, is acceptable to determine the pressure rating.

(3) Except as allowed in (4), all temporary closures shall be threaded, flanged with full bolting, or attached with full penetration welds; welded temporary closures must be so placed to preclude distortion or damage to the vessel or piping being tested.

Threaded connections shall conform to the following table:

MINIMUM NUMBER OF THREADS PER CONNECTION

(a) Pressures up to and including 300 psi							
Size of pipe connection, in. <input type="text"/>	1 & 1/4	1 1/2 & 2	2 1/2 to 4	4 1/2 to 6	7 & 8	9 & 10	12
Threads engaged	4	5	7	8	10	12	13
Min. plate thickness required, in.	0.348	0.435	0.875	1.0	1.25	1.5	1.625
(b) Pressures above 300 psi							
Size of pipe connection, in.	1/2 & 3/4	1 to 1 1/2	2	2 1/2 to 3	4 to 6	10	12
Threads engaged	6	7	8	8	10	13	14
Min. plate thickness required, in.	0.43	0.61	0.70	1.0	1.25	1.62	1.75

(4) The use of expansion plugs or serrated plugs without through stays is limited to 6 " nominal pipe size and/or 150 psi; for use of such devices above these limits specific written test procedures must be developed by the employer to protect against injury in the event the plug blows out.

Such instructions may include applicable data and recommendations furnished by the plug manufacturer and must include the following as a minimum:

- (A) Identification by function of the personnel responsible for the various procedures.
- (B) The test plugs must be well maintained and inspected by the designated employee before use.
- (C) Any opening to be plugged shall satisfy any limitation on straightness, roundness and diameter and shall be cleaned of dirt, mill scale or oil.
- (D) The plug must be of the correct size and pressure rating, including any limitations on the test fluid or test temperature. It must be inserted for full length of engagement, in accordance with the plug manufacturer's instructions.

(E) The test piece must be so oriented to minimize probability of the plug striking personnel or equipment if the plug is ejected. All air must be vented from objects to be hydrostatically tested. Test plugs shall be barricaded or equipped with arresting devices when pneumatic pressure is used for testing.

(F) Provision shall be provided for safe egress. No one shall be allowed to stand in front of the test plug or in line of probable trajectory during test.

(G) No one shall be allowed to stand on top of the object being tested, or on a ladder to the test section until the test object is brought up to full test pressure, held at test pressure for at least ten minutes, and pressure is reduced to a predetermined safe level.

(H) Pressurization shall be stopped at intervals to check pressure gage (s) and position of test plug (s).

(I) The test pressure shall be reduced to zero before the plugs are loosened for removal.

(J) Damaged or expanded closure ends must be cut off.

(K) All repairs to test plugs shall follow the plug manufacturer's instructions.

(5) Pipe test machines are acceptable for use after they have been reviewed by the Division for safe operational procedures.

(6) Pressure during test must be controlled within 5% above the required test procedure. Protection against overpressure must be provided at 110% of the test pressure. A relief valve setting of 133% of the test pressure may be used, for elastic materials only, where calculations show that 133% of the test pressure will not exceed 90% of the specified minimum yield strength of the material. The discharge from the safety relief valve or rupture disc must be led full size to a safe place.

The requirement for a relief valve may be waived by a Qualified Pressure Vessel Safety Engineer or Certified Pressure Vessel Inspector if the only source of test pressure is a handpump.

(e) Railroad tank cars containing compressed gas may not be used for interrupted unloading into smaller containers, unless permitted by the Federal Department of Transportation. Provisions for such unloading shall conform to DOT regulations

See Petroleum Safety Orders, Sections 6879, 6880 and 6881 for requirements covering transfer operations at sidings inside petroleum refineries and distribution plants.

(1) An adequate unloading facility must be provided, and provisions must be made to support the transfer hoses. The transfer attendant must not be required to haul the transfer hoses up or down the tank car ladder.

(2) A bulkhead must be provided to prevent pullaway of the transfer hoses and/or to prevent imposing piping loads on the tank car valves. The bulkhead must be designed to withstand a horizontal pull of at least 2,000 pounds in any direction unless other adequate protection is provided. The unloading

connections shall be firmly secured to the bulkhead. Excess flow valves, check valves or equivalent devices shall be provided where pipe or hose size is reduced.

The Qualified Transfer Attendant shall be instructed in all phases of the transfer operation. The instructions shall include a prohibition against overfilling any tank. Note: All valves in the transfer system must be fully open in order for an excess flow valve to function, so internal valves or check valves should be used whenever possible. The tank car excess flow valves are located in the internal piping beneath the dome.

NOTE: Bonding and grounding of the tankcar and transfer equipment may be required for compressed flammable gases by railroad leasing agreement or by the local fire official.

(3) Written notification shall be given the Division and the local fire official of each non-permanently equipped transfer site. In emergencies, verbal notice may be given followed by written confirmation. Each such site shall be located, with respect to the minimum distance tables as outlined in Section 501(c) for NH<sub>3</sub> or Sections 475(a) and (b) for Flammable Compressed Gas. Sites for transfer of other compressed gases must be at least 50 feet from railroad main track or important buildings. The working areas must be kept clear of debris and all transfer equipment must be protected from physical damage. Transfer shall be done only during daylight hours unless the transfer area is equipped with a lighting system and which provides at least 5 foot candles of illumination at all points of operations.

(4) Vehicle and tank car wheels must be blocked during transfer. Tank car brakes must be set. Tank cars must not be left connected to hoses and/or pipelines except during the unloading operation and while the qualified transfer attendant is present and in charge, unless the tank car valves are closed and locked, hoses are depressurized and/or a hydrostatic relief valve is installed between shutoff valves.

Valves on vehicles must be closed and locked except during transfer. Where vehicular container valves cannot be locked closed, the filling hose(s) must be disconnected when the qualified attendant is not present.

(5) Transport tank trucks and towed vehicles may load into the tank cars if they are also equipped with pullaway protection, in addition to meeting the requirements of paragraphs (1) through (4). A brake interlock system that is acceptable to the Division, and is connected to the truck tank unloading hose connection, is considered as an adequate pullaway safeguard.

Personal protective devices and safety equipment which are required and used for stationary storage facilities must be provided. Fire extinguishers must be provided for flammable compressed gases and anhydrous ammonia as required by the applicable safety order.

## **Credits**

### **HISTORY**

1. New subsection (e) filed 5-6-77; effective thirtieth day thereafter (Register 77, No. 19). For prior history, see Register 76, No. 51.



## Appendix A Minimum Capacity Requirement of Relief Valves for Fire Exposure for Liquefied Natural Gas Tanks and Vaporizers

---

A1. The minimum total heat influx during a possible fire exposure of an insulated container shall be computed by the applicable formula:

NOTE: Equation (1) shall be used for vaporizers with external insulation and Equation (2) for uninsulated vaporizers. The value of A is obtained by adding the area of the shell in contact with LN-Gas and the area of heat exchange surface in contact with LN-Gas.

$$(1) H = 1560C_1A^{0.82} + H_n$$

where:

H = Total heat influx, Btu per hour.

$C_1$  = Conductance of the insulation, Btu/sq. ft.-hr. -deg. F. (The value of C increases with temperature and a mean value for the range from -260 F to +1660 F should be used.)

A = Total exposed wetted surface area in sq. ft.

$H_n$  = Total normal heat gain to the stored liquid without fire exposures and at maximum ambient temperatures, Btu per hour.

A2. If the insulation system, including any jacketing material, is such that it will disappear, deteriorate or dislodge in an exposure fire, a higher heat gain will occur. This requires special consideration depending upon the extent of loss of the insulating properties. If only a part of the insulation is lost, the heat gain may be estimated by the formula:

$$(2) H = (34,500 - 360C_2) A^{0.82} + H_n$$

In this case, the value of  $C_2$  should be the mean value for the range from -260 F to +100 F.

A3. The required relief valve capacity shall be computed by the formula

$$(3) Q_a = 3.09 (H/L)V(T/M)$$

where:

$Q_a$  = Required flow capacity of air, cu. ft. per hour at 60 F and 14.7 psia.

H = Total heat influx, Btu per hour from the formula (1) or (2).

L = Latent heat of vaporization of the stored liquid, Btu per lb. (219 may be used for LN-Gas).

T = Absolute temperature of the gas at the relief valve inlet, deg. R.

M = Molecular weight of the gas (16.0 may be used for LNG).

## Credits

## HISTORY

1. Relocation of Appendix A filed 12-14-76; effective thirtieth day thereafter (Register 76, No. 51).

## Appendix B

---

3301.<sup>1</sup> Use of Compressed Air or Gases.

(a) Compressed air and other compressed gases in excess of 10 pounds per square inch gauge shall not be used to blow dirt, chips, or dust from clothing while it is being worn.

(b) Compressed air or gases shall not be used to empty containers of liquids where the pressure can exceed the safe working pressure of the container.

(c) The use of compressed air shall be so controlled, and proper personal protective equipment or safeguards utilized, as to protect against the possibility of eye or body injury to the operator or other workers.

(d) Abrasive blast cleaning nozzles shall be equipped with an operating valve which must be held open manually. A support shall be provided on which the nozzle may be mounted when it is not in use.

(e) Compressed gases shall not be used to elevate or otherwise transfer any hazardous substance from one container to another unless the containers are designed to withstand, with a factor of safety of at least four, the maximum possible pressure that may be applied.

NOTE: For further guidance in the utilization of compressed gases in cylinders see Group 10; for portable tanks, rail tank cars, or motor vehicle cargo tanks, see Compressed Gas Association Pamphlet P-1-~~1965~~2022.

-----

<sup>1</sup> Reprint General Industry Safety Order, Section 3301, Use of Compressed Air or Gases, from the California Administrative Code, Title 8, Subchapter 7 (Register 75, No. 29).

3304.<sup>2</sup> Miscellaneous Use of Compressed Cylinder Gas.

(a) Employers shall not permit the use of compressed cylinder gas for testing pressure vessels unless there is installed in the compressed gas supply line or on the vessel being tested a pressure relief device set to function at a pressure not to exceed the safe working pressure of the vessel.

(b) Compressed gas shall never be used from a cylinder or cylinder manifold where pressures dangerous to employees may develop unless an accepted pressure regulating device is installed on the cylinder valve or manifold. The term "accepted" here means that the pressure regulating device is listed by Underwriters' Laboratories or some other recognized authority of equivalent standing.

NOTE: Cylinder as used in this order means an ~~Interstate Commerce Commission~~ Department of Transportation (DOT) compressed gas cylinder.

-----

<sup>2</sup>Reprint General Industry Safety Order, Section 3304, Miscellaneous Use of Compressed Cylinder Gas, from the California Administrative Code, Title 8, Subchapter 7 (Register 72, No. 23).

3312.<sup>3</sup> Entering Combustion Chambers, Flues, Boilers or Unfired Steam Pressure Vessels.

(a) Before employees are allowed to enter, through a manhole, the shell or drum of a steam boiler or an unfired steam pressure vessel for maintenance or repair, where such a boiler or pressure vessel is one of a battery of two or more boilers or vessels or is connected to another source of steam, the valves connecting to the steam header or other source of steam shall be closed and effectively blinded or two valves shall be installed with a bleeder between them and the valves shall be closed and bleeder open. Blow down valves and other valves on lines through which harmful material might accidentally flow back to the boiler or vessel shall be either sealed or closed and locked and the key retained by the employee or his supervisor while the employee is in the boiler or vessel. When lines are effectively blinded the valves need not be locked or sealed.

(b) Employees shall not enter or be required to enter the fire boxes, flues or combustion chambers of fired apparatus until:

(1) The pilot light, fuel and steam lines to burners entering the fire box or combustion chamber have been blinded, disconnected or effectively closed by the use of two block valves with an open bleeder between them.

(2) All probability of ignition of any solid combustibles in the fire box or combustion chamber has been removed.

-----

<sup>3</sup>Reprint of General Industry Safety Order, Section 3312, Entering Combustion Chambers, Flues, Boilers or Unfired Steam Pressure Vessels, from the California Administrative Code, Title 8, Subchapter 7 (Register 72, No. 23).

3518.<sup>4</sup> Air Compressors.

(a) Air compressor discharge lines having a block valve between the air receiver and compressor shall have a pressure relieving safety device installed in the line between the compressor and block valve. The pressure relieving safety device shall be set to open at a pressure not to exceed the rated working pressure of the cylinder. The relieving capacity of the pressure relieving safety devices shall be such as to prevent a rise of pressure in the compressor cylinder of more than 10 percent above its maximum allowable working pressure, and the discharge shall be to a safe place.

The installation of this pressure relieving safety device is not to be considered as providing the required safety relief valve for the protection of the air receiver.

(b) Air compressor intake lines shall not be located in atmospheres containing explosive concentrations of flammable gases or vapors.

-----

<sup>4</sup>Reprint of General Industry Safety Order, Section 3518, Air Compressors, from the California Administrative Code, Title 8, Subchapter 7 (Register 72, No. 23).

#### **Credits**

NOTE: Authority cited: Section 142.3, Labor Code.

#### **HISTORY**

1. New Appendix B (Sections 3301, 3304, 3312, and 3518) filed 12-14-76; effective thirtieth day thereafter (Register 76, No. 51).

### ***Appendix C Acceptance Tests for Plastic Piping***

#### Appendix C Acceptance Tests for Plastic Piping

The following are tests that shall be passed for acceptance of plastic piping for the conveyance of compressed air:

1. Test for impact resistance at 0°C: (32° F)

Objective: To determine if the material will withstand the energy of impact without fracturing through the complete wall thickness.

Form of test specimen: Each specimen shall be a section of pipe, of a length equal to twice the nominal

size or 150 mm (6" ), whichever is greater, subject to a maximum length of 300 mm (12" ). The ends of the specimen shall be cut clean and equal to the axis of the pipe.

For "round-the-clock" testing, each specimen shall be marked with the number of longitudinal lines shown in Table 1.

NOTE: For pipe sizes 50 mm (2 " ) and over, specimens are subjected to impact equally spaced around the pipe; this procedure is known as "round-the-clock" testing.

Apparatus: A falling weight machine (an example of which is shown in Figure 1) shall be used and shall consist essentially of the following:

- a. A main frame which can be rigidly fixed in a true vertical position.
  
- b. Guide rails, carried from the inside of the main frame, on side bearings which can be adjusted to keep them parallel and vertical.
  
- c. A weighted striker that can fall freely within the guide rails and that is equipped with a hardened hemispherical striking surface 25 mm (1" ) in diameter. The striking surface shall be free from flats and/or other imperfections.
  
- d. An appropriate set of weights which can be firmly attached to the striker to enable the combined weight to be adjusted to the values shown in Table 2.

Procedure: Adjust the total energy of the striker to the value appropriate to the pipe diameter being tested as shown in Table 2.

Condition each specimen in a water or ethylene glycol bath for at least one hour prior to the test at a temperature of  $0^{\circ}\text{C}$  ( $32^{\circ}\text{F}$ )  $\pm 1^{\circ}$ . Test individual specimens within 10 seconds of removal from the bath. allow the striker to fall freely onto the pipe specimen, which is centrally mounted on the vee block support.

Specimens from 10 mm (3/8" ) to 38 mm (1-1/2" ) (inclusive) nominal size shall be subjected to a single strike only.

For pipe size 50 mm (2" ) and above. Place the pipe on the vee block, so that one of the marked lines is uppermost. Then allow the weight striker to fall freely on the marked line on the pipe as described above. If the specimen does not fail as a result of cracking or splitting through the pipe wall, rotate the specimen until the next marked line is uppermost in the vee block, and cause a second blow to be made by the striker. Repeat the process until all the marked lines have been tested, or until a failure is recorded.

If the required sequence of impacts has not been completed within 10 seconds, interrupt the procedure and immediately recondition the specimen at a temperature of 0°C (32° F) + 1° for at least 10 minutes.

Fracturing or cracking through the complete wall thickness of the test specimen shall be a failure.

The following tests (Nos. 2 & 3) are intended to simulate a potential destructive impact. Splitting through the pipe wall or puncture is acceptable for passing results, if:

(a) No separation of one part of piping length from its mating part occurs.

(b) No separation of any material fragment from the body of the piping occurs.

2. Test for impact resistance at design pressure at 0°C (32°F) with blunt striker. Testing procedures and apparatus shall be the same as Test No. 1, except:

(a) Pressurize and maintain pipe sample at design pressure and cool to 0° C (32° F) as in Test No. 1.

(b) Energy of the striker to be twice the total energy of Table 2.

(c) Only one drop required.

3. Test for impact resistance at design pressure at 0° C (32° F) with sharp striker. Same as Test No. 2 in all cases, except with a chisel edged sharp striker (Figure 2).

4. The plastic piping systems shall be capable of sustaining without failure at least 600 psi when tested to the Standard Test Method for Short-Time Hydraulic Failure Pressure of Plastic Pipe, Tubing, and Fittings, using ASTM Designation No. D1599-86 (1986) which is herein incorporated by reference. This test shall be performed on each batch of pipe and fittings.

5. The plastic piping system shall be capable of sustaining without failure at least 460 psi when tested to the Standard Test Method for Time-to-Failure of Plastic Pipe Under Constant Internal Pressure using ASTM Designation No. D1598- 86 (1986), which is herein incorporated by reference, for at least 1,000 hours. This test shall be performed anytime there is a change in:

(a) material composition, compound or processing technique;

(b) design or size of joint or fitting;

(c) but, in any case not less than every 12 months.

Table 1. Number of Lines For "Round-the-Clock" Testing

Normal Size mm (inches)	Number of Equidistant Lines to be Drawn
50 mm (2")	3
63 mm (2-1/2")	4
75 mm (3")	4
100 mm (4")	6

Table 2. Energy of Striker

Normal Size of Pipe mm (inches)	Total Energy of Striker ft. lbs.
10 mm (3/8")	22
12 mm (1/2")	33
19 mm (3/4")	43

25 mm (1")	54
38 mm (1-1/2")	65
50 mm (2")	76
63 mm (2-1/2")	98
75 mm (3")	98
100 mm (4")	110

(c) Whenever an owner or user of any apparatus or equipment fails to pay the fees required under this section within 60 days after notification, said owner or user shall pay, in addition to the fees required under this section, a penalty fee equal to 100 percent of such fee. For the purpose of this section, the date of the invoice shall be considered the date of notification.



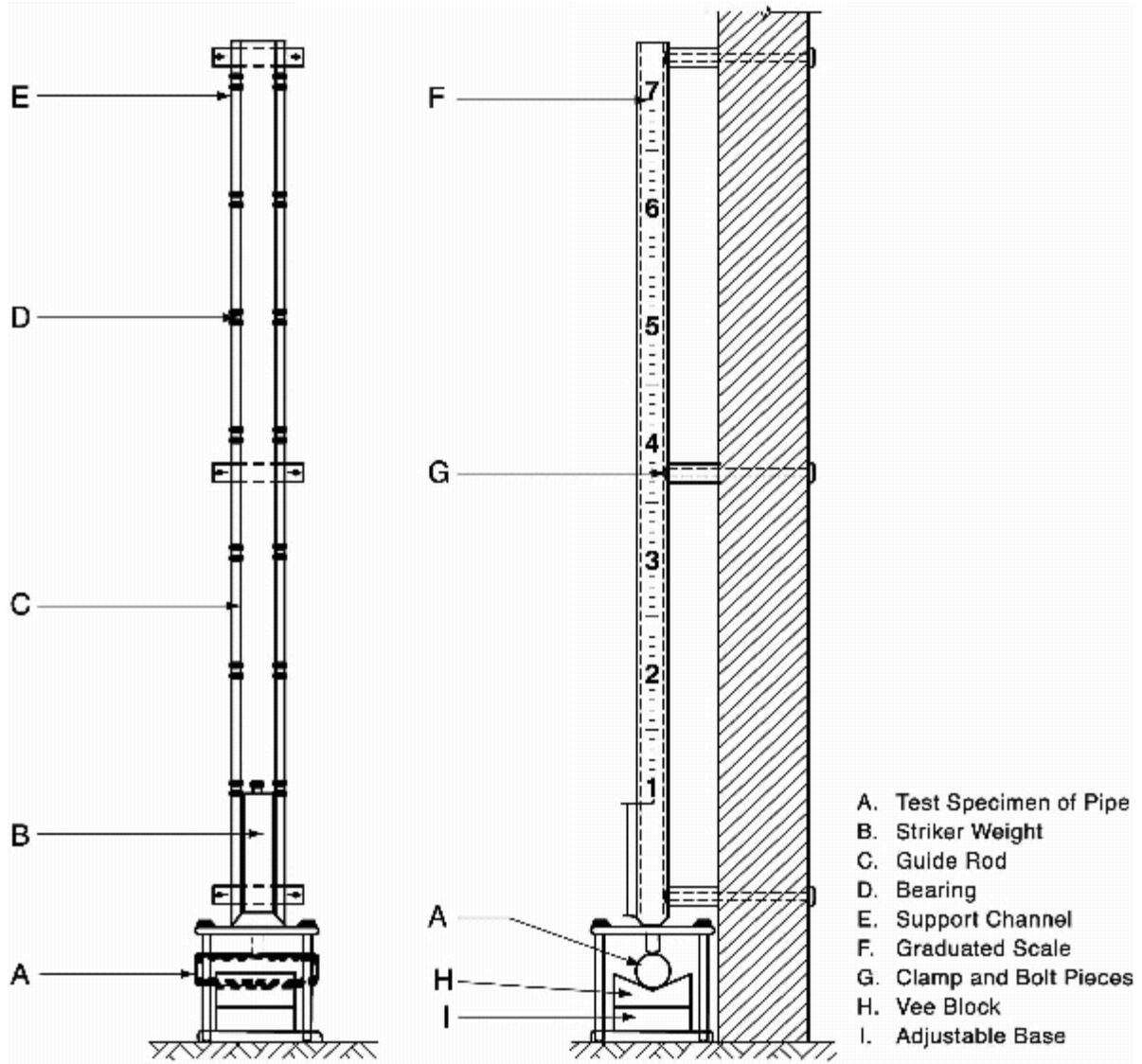

Figure 1 - Suitable Impact Testing Machine

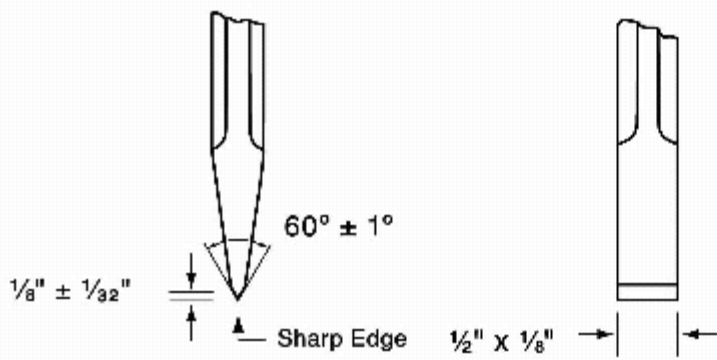

Figure 2 - Chisel Edged Sharp Striker

Image 1 (8.5" X 6") Not available for Offline Print to STP or FAX

<General Materials (GM) - References, Annotations, or Tables>

### Credits

### HISTORY

1. New Appendix C filed 3-28-78; effective thirtieth day thereafter (Register 78, No. 13).
2. Repealer and new Appendix C filed 4-8-92; operative 5-8-92 (Register 92, No. 18).
3. Change without regulatory effect providing more legible illustrations filed 8-4-2008 pursuant to section 100, title 1, California Code of Regulations (Register 2008, No. 32).

### Appendix D (Repealed)

**FORM R-1 REPORT OF WELDED REPAIR**  
in accordance with provisions of the National Board Inspection Code

1. Work performed by \_\_\_\_\_ (name of repair organization) (Form R-1a)  
\_\_\_\_\_ (address) (P.O. Box No. etc.)

2. Owner \_\_\_\_\_ (address)  
\_\_\_\_\_ (name)

3. Location of installation \_\_\_\_\_ (address)  
\_\_\_\_\_ (name)

4. Unit identification \_\_\_\_\_ (address)  
Name of original manufacturer \_\_\_\_\_

5. Identifying nos.: \_\_\_\_\_ (original pressure vessel) \_\_\_\_\_ (national Board No.) \_\_\_\_\_ (jurisdiction No.) \_\_\_\_\_ (year built)

6. NBIC Edition/Addenda \_\_\_\_\_ (year) \_\_\_\_\_ (edition)  
Original Code of Construction for Item \_\_\_\_\_ (name of construction code)  
Construction Code Used for Repair Performed \_\_\_\_\_ (name of construction code)

7. Description of work: \_\_\_\_\_ (use supplemental sheet, Form R-1a, if necessary)  
Pressure Test, if applied: \_\_\_\_\_ psi \_\_\_\_\_ MAWP \_\_\_\_\_ psi

8. Replacement Parts: Attached are Manufacturer's Part Data Reports or Form R-3a properly completed for the following items of this report: \_\_\_\_\_  
Name of part, manufacturer, size report type, type, name and identifying brand

9. Remarks: \_\_\_\_\_

**CERTIFICATE OF COMPLIANCE**  
I, \_\_\_\_\_, certify that to the best of my knowledge and belief the statements in this report are correct and that all material, construction, and workmanship on this Repair conforms to the National Board Inspection Code National Board "R" Certificate of Authorization No. \_\_\_\_\_, expires on \_\_\_\_\_.

Date \_\_\_\_\_ Signed \_\_\_\_\_ (authorized representative)

**CERTIFICATE OF INSPECTION**  
I, \_\_\_\_\_, holding a valid Commission issued by The National Board of Boiler and Pressure Vessel Inspectors and certificate of competency issued by the jurisdiction of \_\_\_\_\_, and employed by \_\_\_\_\_, have inspected the work described in this report on \_\_\_\_\_ and state that to the best of my knowledge and belief this work complies with the applicable requirements of the National Board Inspection Code.

By signing this certificate, neither the undersigned nor my employer makes any warranty, expressed or implied, concerning the work described in this report. Furthermore, neither the undersigned nor my employer shall be liable in any manner for any personal injury, property damage or loss of any kind arising from or connected with this inspection.

Date \_\_\_\_\_ Signed \_\_\_\_\_ (inspector) \_\_\_\_\_ (national Board and jurisdiction, and jurisdiction, and No.)

**FORM R-2 REPORT OF ALTERATION**  
in accordance with provisions of the National Board Inspection Code

1. Work performed by \_\_\_\_\_ (Name of alteration organization) (Form R No.) \_\_\_\_\_

2. Owner \_\_\_\_\_ (Name) \_\_\_\_\_ (Address) \_\_\_\_\_ (City, State, Zip, Co. and Cn.) \_\_\_\_\_

3. Location of installation \_\_\_\_\_ (Name) \_\_\_\_\_ (Address) \_\_\_\_\_

4. Unit identification \_\_\_\_\_ (Name of original manufacturer)

5. Identifying nos.: \_\_\_\_\_ (Joint, pressure vessel) \_\_\_\_\_ (National Board No.) \_\_\_\_\_ (Transaction No.) \_\_\_\_\_ (Other) \_\_\_\_\_ (Year built)

6. NBIC Edition/Addenda \_\_\_\_\_ (Edition) \_\_\_\_\_ (Addenda)

Original Code of Construction for item: \_\_\_\_\_ (Name of original manufacturer) \_\_\_\_\_ (Section/Division)

Construction Code Used for Alteration Performed: \_\_\_\_\_ (Name of original manufacturer) \_\_\_\_\_ (Section/Division)

7. Description of work: \_\_\_\_\_ (See supplemental sheet, Form R-2, if necessary)

---

Pressure Test, if applied:  Yes  No

8. Replacement Parts: Attached are Manufacturer's Partial Data Reports or Form R-2's properly completed for the following items of this report: \_\_\_\_\_

9. Remarks: \_\_\_\_\_

Form R-2 (back)

(Form R No.)

**DESIGN CERTIFICATION**

I, \_\_\_\_\_, certify that to the best of my knowledge and belief the statements in this report are correct and that the Design Change described in this report conforms to the National Board Inspection Code, National Board "R" Certificate of Authorization No. \_\_\_\_\_ expires on \_\_\_\_\_.

Date \_\_\_\_\_ Signed \_\_\_\_\_ (Name of design organization) (Authorized representative)

---

**CERTIFICATE OF DESIGN CHANGE REVIEW**

I, \_\_\_\_\_, holding a valid Commission issued by The National Board of Boiler and Pressure Vessel Inspectors and certificate of competency issued by the jurisdiction of \_\_\_\_\_ and employed by \_\_\_\_\_, have reviewed the design change as described in this report and state that to the best of my knowledge and belief such change complies with the applicable requirements of the National Board Inspection Code.

By signing this certificate, neither the undersigned nor my employer makes any warranty expressed or implied, concerning the work described in this report. Furthermore, neither the undersigned nor my employer shall be liable in any manner for any personal injury, property damage or loss of any kind arising from or connected with this inspection.

Date \_\_\_\_\_ Signed \_\_\_\_\_ (Inspector) Commissioned \_\_\_\_\_ (National Board (inc. endorsement, and jurisdiction, see an.)

---

**CONSTRUCTION CERTIFICATION**

I, \_\_\_\_\_, certify that to the best of my knowledge and belief the statements in this report are correct and that all materials, construction, and workmanship on this Alteration conforms to the National Board Inspection Code, National Board "R" Certificate of Authorization No. \_\_\_\_\_ expires on \_\_\_\_\_.

Date \_\_\_\_\_ Signed \_\_\_\_\_ (Name of alteration organization) (Authorized representative)

---

**CERTIFICATE OF INSPECTION**

I, \_\_\_\_\_, holding a valid Commission issued by The National Board of Boiler and Pressure Vessel Inspectors and certificate of competency issued by the jurisdiction of \_\_\_\_\_ and employed by \_\_\_\_\_, have inspected the work described in this report on \_\_\_\_\_ of \_\_\_\_\_ and state that to the best of my knowledge and belief this work complies with the applicable requirements of the National Board Inspection Code.

By signing this certificate, neither the undersigned nor my employer makes any warranty expressed or implied, concerning the work described in this report. Furthermore, neither the undersigned nor my employer shall be liable in any manner for any personal injury, property damage or loss of any kind arising from or connected with this inspection.

Date \_\_\_\_\_ Signed \_\_\_\_\_ (Inspector) Commissioned \_\_\_\_\_ (National Board (inc. endorsement, and jurisdiction, see an.)

## Credits

NOTE: Authority cited: Section 142.3, Labor Code. Reference: Section 142.3, Labor Code.

## HISTORY

1. New Appendix D filed 1-30-2002; operative 3-1-2002 (Register 2002, No. 5).

This database is current through 1/13/23 Register 2023, No. 2.

Cal. Admin. Code tit. 8, Div. 1 Ch. 4 Subch. 1 App. D, 8 CA ADC Div. 1 Ch. 4 Subch. 1 App. D